

Littelfuse produces four families of multilayer suppressors: the ML, MLE, MLN and AUML. While much of the information presented here is generic to all four, this note focuses on the ML version.

Introduction

Sensitivity of Components

Modern electronic circuits can be vulnerable to damage from voltage transient overstresses. The progress in the development of faster ICs with higher levels of integration can be accompanied by an increase in vulnerability. Figure 1 shows relative damage susceptibility of some commonly used components, including discrete semiconductors and integrated circuits [1, 2].

The voltage, current, or power seen by a device must be below the failure threshold of the device. The magnitude of any voltage transient is determined by the nature of the source, the characteristic impedance of the circuit and the resistance and inductance between the source of the transient and the device.

The Transient Threat

Transients exist in every AC or DC system, or any wire connecting two pieces of equipment or components. The sources of the transient can be lightning, nuclear electromagnetic pulse, high energy switching and high voltage sparkover, or electrostatic discharge. These transients may be

found wherever the energy stored in inductances, capacitors, or mechanical devices, such as motors and generators, is returned to a circuit. Stray capacitance and inductance may also set off oscillations, making the problem even worse.

While a direct hit from lightning is not of real concern for a printed circuit board user, what may be of concern is the level of the transient which is "let through" by the primary suppressor. This "follow on current" may be up to 50A and it will last for a number of microseconds. If this current is above the failure threshold of a device in the circuit, it will be destroyed.

The two most likely types of transients from which a circuit must be protected are electrostatic discharge (ESD), and the switching of reactive loads. ESD will result when two conducting materials are brought close to one another and a voltage discharge occurs. The resulting voltage discharge can be as high as 25kV and will last up to 50ns. Transients can also be generated when an inductive load is disconnected and the existing energy is discharged back into the circuit. The arc generated from the opening of mechanical relay switches is another common source of switching transients.

Whatever the cause of the transient, natural or man-made, the damage potential is real and cannot be casually dismissed if reliable operation of equipment is to be expected. To properly select a transient suppressor, the frequency of occurrence of transients, the open-circuit voltage, the short circuit-current, and the source impedance of the circuit must be known.

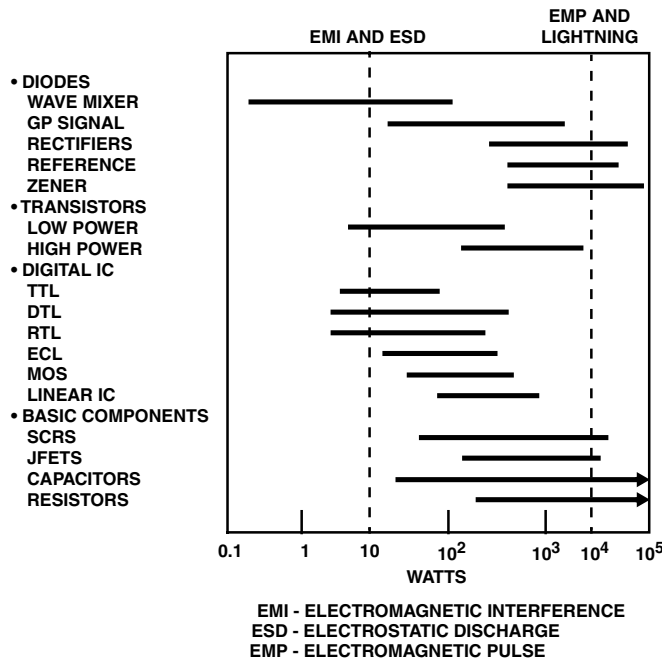

FIGURE 1. RELATIVE DAMAGE SUSCEPTIBILITY OF ELECTRONIC COMPONENTS (FOR 1µs PULSE)

Multilayer Surge Suppressor Description

The Littelfuse multilayer (ML) series of transient voltage surge suppressors represents a breakthrough in the area of semiconducting ceramic processing. The ML suppressor is a compact, surface mountable chip that is voltage dependent, nonlinear, and bidirectional. It has an electrical behavior similar to that of a back-to-back diode, i.e. it is inherently fully symmetrical, offering protection in both forward and reverse directions. The sharp, symmetrical breakdown characteristics of the device provides excellent protection from damaging voltage transients (Figure 2). When exposed to high voltage transients, the ML impedance changes many orders of magnitude from a near open circuit to a highly conductive state.

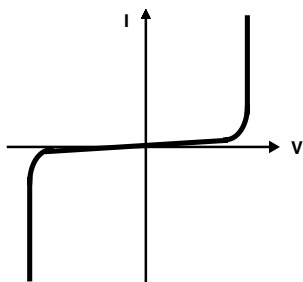

FIGURE 2. SHARP SYMMETRICAL BREAKDOWN OF MULTILAYER SUPPRESSOR

Construction

The ML is constructed by forming a combination of alternating electrode plates and semiconducting ceramic layers into a block. Each alternate layer of electrode is connected to opposite end terminations (Figure 3). The interdigitated block formation greatly enhances the available cross-sectional area for active conduction of transients. This paralleled arrangement of the inner electrode layers represents significantly more active surface area than the small outline of the package may suggest. This increased active surface area results in proportionally higher peak energy capability.

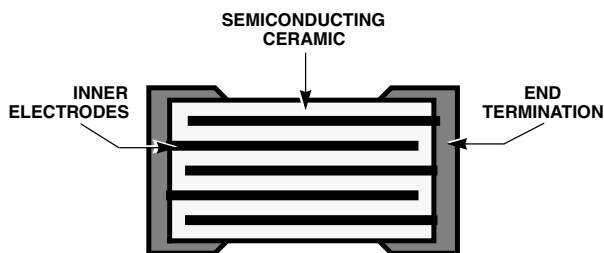

FIGURE 3. MULTILAYER INNER ELECTRODES AND SEMICONDUCTING CERAMIC (CROSS-SECTION)

Another advantage of this type of construction is that the breakdown voltage of the device is dependent on the dielectric thickness between the electrode layers and not the overall thickness of the device. Increasing or decreasing the dielectric thickness will change the breakdown voltage of the device.

Energy handling capability can be significantly increased with a larger overall package outline. The energy handling capability doubles from 0.6J (10/1000 μ s waveform) for a 0.120 inch by 0.06 ("1206") inch device to 1.2J for a 0.120 inch by 0.100 ("1210") inch device.

The crystalline structure of the ML transient voltage suppressor (TVS) consists of a matrix of fine, conductive grains separated by uniform grain boundaries, forming many P-N junctions (Figure 4). These boundaries are responsible for blocking conduction at low voltages, and are the source of the nonlinear electrical conduction at higher voltages. Conduction of the transient energy takes place between these P-N junctions. The uniform crystalline grains act as heat sinks for the energy absorbed by the device in a transient condition, and ensures an even distribution of the transient energy (heat) throughout the device. This even distribution results in enhanced transient energy capability and long term reliability.

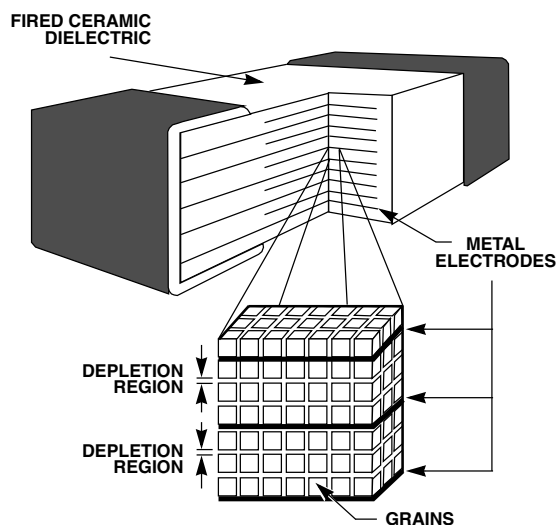

FIGURE 4. MULTILAYER TRANSIENT VOLTAGE SUPPRESSOR

Package Outline

The ML surge suppressor is a leadless chip device that is much smaller in size than the components it is designed to protect. The present size offerings are "0603", "0805", "1206", "1210", "1812" and "2220" EIA chip sizes. See the Littelfuse ML, MLE, MLN and AUML data sheets for detailed device information and size offering. Since the device is inherently bidirectional, symmetrical orientation for placement on a printed circuit board is not a concern. Its robust construction makes it ideally suitable to endure the thermal stresses encountered in the soldering, assembling and manufacturing steps involved in surface mount applications. As the device is inherently passivated by the fired ceramic material, it will not support combustion and is thus immune to any risk of flammability which may be present in the plastic or epoxy molded parts used in industry standard packages.

Characteristics

Speed of Response

The clamping action of the ML suppressor depends on a conduction mechanism similar to that of other semiconductor devices. The response time of the zinc oxide material itself has been shown to be less than 500ps [3, 4, 5]. The apparent slow response time often associated with zinc oxide is due to parasitic inductance in the package and leads. Thus, the single most critical element affecting the response time of any suppressor is its lead length and, hence, the inductance in the leads. As the ML suppressor is a true surface mount device, with no leads or external packaging, it has virtually zero inductance. In actual applications, the estimation of voltage overshoot is of more practical relevance than that of speed of response. As a multilayer suppressor has essentially zero inductance it has little or no voltage overshoot. The actual response time of a ML surge suppressor is 1ns to 5ns. This response time is more than sufficient for the transients which are likely to be encountered by a component on a printed circuit board.

Clamping Voltage

The clamping voltage of a suppressor is the peak voltage appearing across the device when measured under the conditions of a specified pulse current and specified waveform. The industry recommended waveform for clamping voltage is the 8/20μs pulse which has been endorsed by UL, IEEE and ANSI. The clamping voltage of the ML should be the level at which a transient must be suppressed to ensure that system or component failure does not occur. Shunt-type suppressors like the ML are used in parallel to the systems they protect. The effectiveness of shunt suppressors can be increased by understanding the important influence that source and line impedance play in a system, such as is shown in Figure 5.

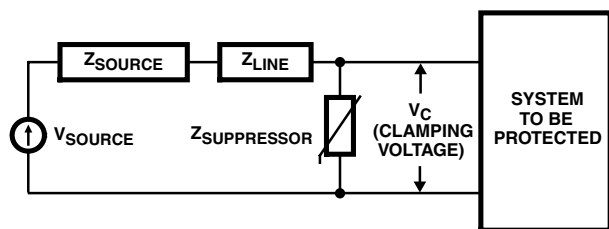

FIGURE 5. VOLTAGE DIVISION BETWEEN SOURCE, LINE AND SUPPRESSOR IMPEDANCE

To obtain the lowest clamping voltage (V_C) possible, it is desirable to use the lowest suppressor impedance ($Z_{SUPPRESSOR}$) and the highest line impedance (Z_{LINE}). The suppressor impedance is an inherent feature of the device, but the line impedance can become an important factor, by selecting location of the suppressor, or by adding resistances or inductances in series.

$$V_C = \frac{V_{SUPPRESSOR} \times V_{SOURCE}}{Z_{SUPPRESSOR} + Z_{LINE} + Z_{SOURCE}}$$

Temperature Dependence

In the off state, the V-I characteristics of the ML suppressor approaches a linear (ohmic) relationship and shows a temperature dependent affect (Figure 6). The suppressor is in a high resistance mode (approaching $10^6\Omega$) and appears as a near open circuit. This is equivalent to the leakage region in a traditional zener diode. Leakage currents at maximum rated voltage are in the microamp range. When clamping transients at higher currents (at and above the milliamp range), the ML suppressor approaches a near short circuit. Here the temperature variation in the characteristics of the ML becomes minimal throughout the full peak current and energy range (Figure 7). The clamping voltage of a multilayer transient voltage suppressor is the same at 25°C and at 125°C.

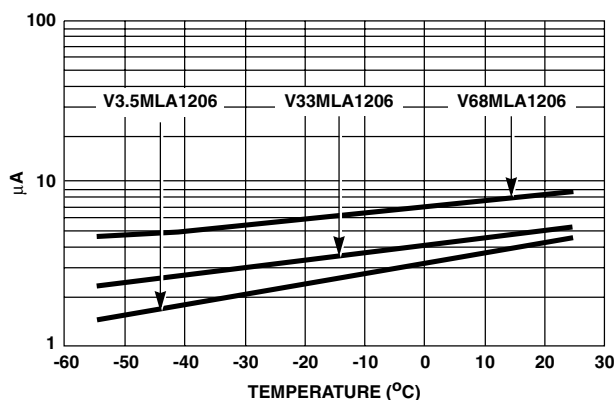

FIGURE 6. TEMPERATURE DEPENDENCE AT LOWER VOLTAGE

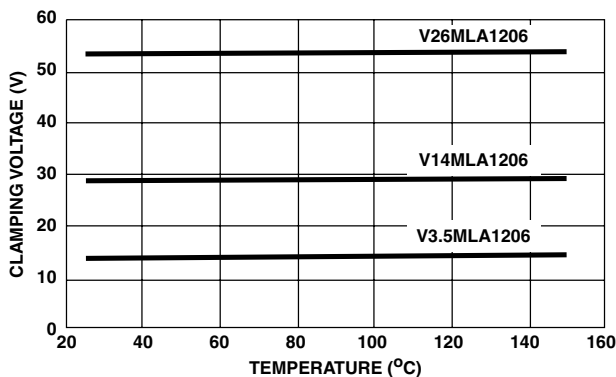

FIGURE 7. CLAMPING VOLTAGE VARIATION OVER TEMPERATURE

Peak Current Capability

The peak current handling capability, and hence its ability to dissipate transient energy, is one of the ML suppressor's best features. This is achieved by the interdigitated construction of the ML, which ensures that a large volume of suppressor material is available to absorb the transient energy. This structure ensures that the peak temperatures generated by the transient is kept low, because all of the package is available to absorb all the energy.

Application Note 9108

(Figure 8). Because of the low peak temperatures, the ML will experience very low thermal stress, both during heating and cooling.

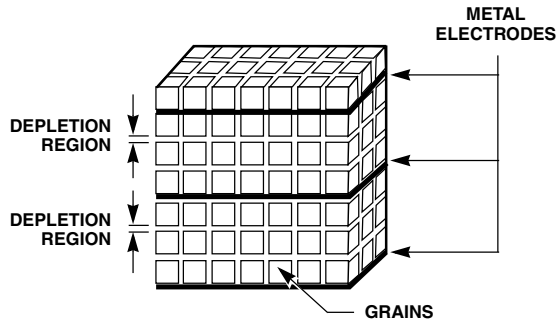

FIGURE 8. INTERDIGITATED CONSTRUCTION

Repetitive pulsing on the ML suppressors (Figure 9) show negligible shift in the nominal voltage at one milliamp (less than 3%). There was also a minimal change in the leakage current of these devices. The Littelfuse ML suppressor can also operate up to 125°C without any need for derating.

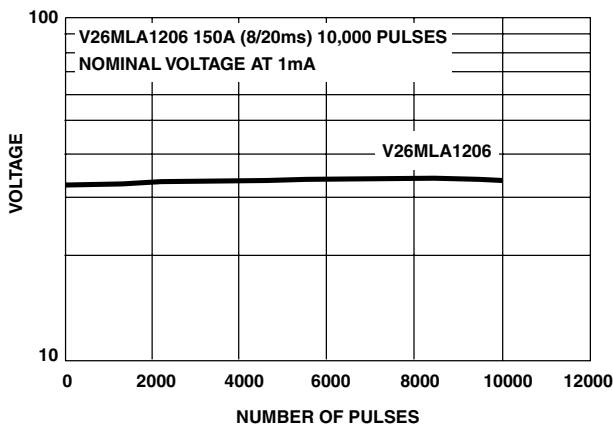

FIGURE 9. REPETITIVE PEAK PULSE CAPABILITY

Capacitance

The ML suppressor is constructed by building up a composite assembly of alternate layers of ceramic material and metal electrode. Since capacitance is proportional to area, and inversely proportional to thickness, the lower voltage MLs have a higher capacitance. See the Littelfuse data sheets for specific values which range from less than 50 to 6000 picofarads. Typical values of capacitance vs frequency are shown in Table 1 (for two types).

TABLE 1. TYPICAL CAPACITANCE VALUES vs FREQUENCY

DEVICE TYPE	CAPACITANCE (pF)			
	FREQUENCY (AT BIAS = 1V _{p-p})			
	1kHz	10kHz	100kHz	1MHz
V5.5MLA1206	6250	5680	5350	5000
V68MLA1206	190	170	160	150

Size

A principal benefit of the new ML suppressor is their compact size in comparison to other surface mount components. Additionally, the solder mounting pads required for ML are much smaller, resulting in even more circuit board area savings.

As stated, the present offering of multilayer suppressor size ranges from 0603 to 2220, depending upon the series type.

Surface mounted surge suppressors include leaded gullwing and j-bend zener diodes or a relatively large surface mount metal oxide varistor. In such cases a large area of the PC board is needed for mounting. Electrically equivalent ML suppressors are much smaller, resulting in significant surface mount PC board area savings (Figure 10). Additional board area savings are realized with the smaller solder mounting area required by the ML as compared to the gullwing or j-bend packages (Figure 11).

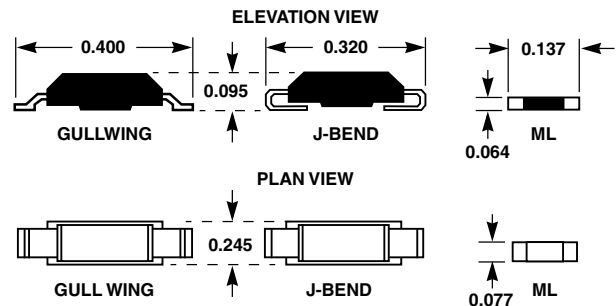

FIGURE 10. COMPARATIVE SURFACE MOUNT SURGE SUPPRESSORS

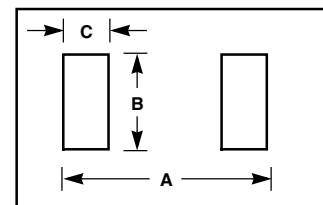

FIGURE 11. SOLDERING LAND PAD REQUIREMENTS

	DIMENSIONS		
	A	B	C
ML1206	0.203	0.103	0.065
Gull Wing	0.410	0.125	0.050
J-Bend	0.330	0.125	0.070

Applications

Protection of Integrated Circuits and Low Voltage Circuits

Protection against the coupling of transients are mainly required at two locations on the printed circuit board. The first is at the input/output port which affords protection of sensitive inputs to line drivers and receivers. The second location is at the power input to the integrated circuits at the input side of the board. This location will serve to keep the transient threat from transmitting throughout the rest of the board.

In the past, IC's have been protected by means of decoupling capacitors across the input power supply lines. The capacitors suppressed transients and supplied peak current for high speed switching operations. Unfortunately, the energy stored in the capacitor, and with it its suppression capability, is very small: $E = 1/2 * C * V^2$.

Large electrolytic capacitors are usually placed on the output of the 5V supply. These capacitors are bulky and somewhat ineffective because of their poor high frequency response. Crowbars are also used to sense overvoltages. The crowbar functions such that an overvoltage shorts the output until the input fuse or circuit breaker opens, thereby turning the system off. Other concerns to consider as well as the power supplies and supply circuitry, are the input and output terminals carrying information. As long as the interconnections are short, transients do not seem to be a problem. However, when connections from board-to-board, system-to-system, or system-to-sensor are considered transients must be controlled (see Figure 12). [7]

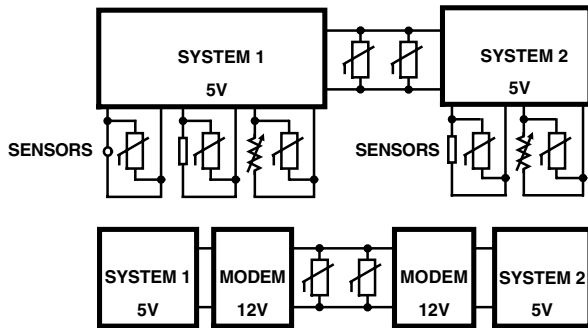

FIGURE 12. SYSTEM-TO-SYSTEM AND SYSTEM-TO-SENSOR PROTECTION

If the distances become long or interconnections between systems result in transient pickup, then transient suppression is a prerequisite. Devices that are more effective than resistors and capacitors are needed to provide the necessary protection. Small spark gaps and silicon suppressors have been used quite effectively, but spark gaps still need a zener diode to reduce the initial voltage rise that triggers the spark gaps.

Silicon suppressors, with their almost ideal V-I characteristics, are used quite extensively. However, zeners have low current-surge capabilities and are of limited value as a transient suppressor when a relatively high magnitude transient is encountered. Surge capability is low because the thermal mass of the silicon chip, where all the energy of the transients is to be converted into heat, is so small. Peak temperatures can become so high that part of the silicon will melt, and the device will fail. On the other hand, there are zener diodes specifically designed for transient suppression. The thermal mass of these devices is increased by attaching more copper to the silicon pellet. This approach helps, but it does not eliminate the basic problem. The transient energy

is still converted into heat in the silicon pellet. The heat travels somewhat faster to the surrounding mass of copper. However, the large temperature differentials still exist. The mismatch of the thermal coefficient of expansion between the silicon and copper will create shearing forces that may lead to failures due to thermal fatigue.

The low voltage V5.5MLA1206 may be used to protect integrated circuits requiring 5V on the input, e.g. all integrated circuits, systems containing low voltage ICs, memories, test equipment, data processing equipment, etc. The suppressor should be connected upstream from the IC to be protected. The maximum clamping voltage of the suppressor depends on the maximum transient current. If the clamping voltage is too high and the signal currents are low, a hybrid arrangement of a multilayer suppressor and a series impedance (an inductor or resistor) may be an effective and low cost solution. The series impedance should be as large as possible without distorting or attenuating the signal appreciably. The clamping voltage of the suppressor should be low, but high enough to prevent attenuation or distortion of the signal.

CMOS Protection

Latch-up is a phenomenon inherent in the basic CMOS structure. It is initiated by external conditions, is present only momentarily, and once induced is difficult to reverse, except by complete removal of power to the chip. Latch-up results in large current flow from V_{CC} to ground. It can be triggered by an increasing voltage across the power terminal, such as an excessive voltage at the V_{CC} pin (normally well above the maximum V_{CC} rating of the device). This can be prevented by connecting a low voltage ML transient suppressor across V_{CC}.

Unfortunately, even if the systems power supply variations are kept small, individual inputs can still vary widely. Latchup is also known to occur in CMOS systems when voltage supplied to an input exceeds the supply voltage. Again, transients can be the culprit; the wrong sequence in power-up or power-down may have the same effect. A ML suppressor connected from V_{CC} to ground will eliminate most of the latch-up problems caused by input over voltage. Additionally an ML suppressor connected from input to ground will help to protect the input from damaging transients such as electrostatic discharge (Figure 13).

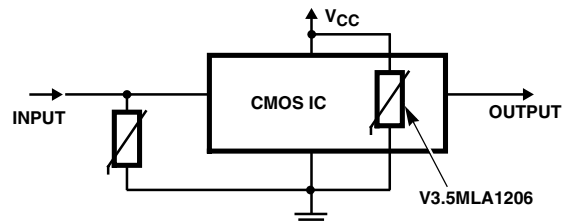

FIGURE 13. PROTECTION OF CMOS DEVICES

Here, the Littelfuse V3.5MLA1206 for example, represents a method of protecting 3.5V CMOS logic.

Discrete MOSFET Protection

There has been an increasing migration from bipolar technology to MOSFET technology. A MOSFET gate could be more susceptible to damage from electrostatic discharges than a bipolar transistor. Also, the consequence of fast MOSFET switching time can be a “ringing” from wiring inductances. This could result in the MOSFET and adjacent components being subjected to short duration transient voltages. MLs can clamp these transients to a safe level.

It is important when using a ML suppressor to connect it as close as possible to the drain and source leads of the MOSFET, in order to minimize the loop inductance. As the ML suppressor is a true surface mount package and has no lead inductance, this ensures that the MOSFET does not suffer the additional transient voltage overshoot associated with leaded suppressors.

To protect the output of the MOSFET, the ML suppressor is connected between the drain and source (Figure 14). This ML must have a steady state voltage capability ($V_{M(DC)}$) which exceeds the worst case possible maximum supply voltage. Its clamping voltage at a peak transient current must be less than the minimum breakdown voltage of the MOSFET. For example, to protect against transients on a $28V \pm 10\%$ supply, the V33MLA1206 ML suppressor with $V_{M(DC)}$ of 33V can be used. According to the transient V-I curves of the ML data sheet, this will protect a MOSFET with a 60V minimum breakdown from an approximate 10A transient pulse.

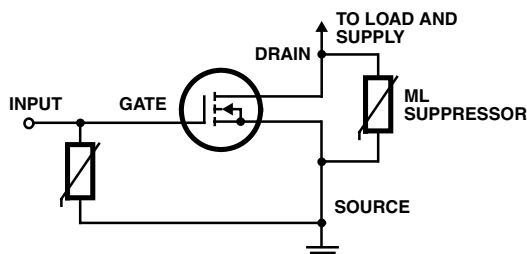

FIGURE 14. DISCRETE MOSFET PROTECTION

Additionally an ML suppressor can be used to protect the input of a discrete MOSFET from the threat of an ESD transient. In the protection of a MOSFET driven with a 10V gate drive, the V14MLA1206 or V14MLA1210 suppressor should be connected from gate to source. These devices will protect against ESD pulses of 2kV to 25kV.

The ML can also be used to protect MOSFETs (and bipolar transistors) from the transients generated when switching inductive loads. In this case, the ML selected must be able to dissipate the energy generated by the repetitive nature of these inductive load transient pulses (the average power of these transients must not exceed 0.25W).

Automotive System Protection

The increased use of surface mount technology in the automotive industry has resulted in the need for smaller,

more densely packed boards with devices which have the performance capabilities of traditional through hole components.

The transient conditions which may occur in the automobile is one of the best documented, and best understood transient environments. A load dump transient will develop when an alternator charging a flat battery is suddenly removed from the system. Peak voltages up to 125V may develop and can last for 200ms-400ms. Another common transient phenomena is a jump start which is generated when using a 24V truck battery to start a car. This overvoltage may be applied for up to 3 to 5 minutes. Other transients result from relays and solenoids switching on and off, and from fuses blowing.

Table 3 shows some sources, amplitudes, polarity, and energy levels of generated transients in the automotive electrical system [8].

TABLE 2. TYPICAL AUTOMOTIVE SUPPLY TRANSIENT SUMMARY

LENGTH OF TRANSIENT	CAUSE	ENERGY CAPABILITY	FREQUENCY OF OCCURRENCE
		VOLTAGE AMPLITUDE	
Steady State	Failed Voltage Regulator	∞	Infrequent
		+18V	
3-5 Minutes	Jump Starts with 24V Battery	∞	Infrequent
		$\pm 24V$	
200ms to 400ms	Load Dump; Disconnection to Battery While at High Charging	>10J	Infrequent
		<125V	
<320ms	Inductive-Load Switching Transient	<1J	Often
		-300V to +80V	
200ms	Alternator Field Decay	< 1J	Each Turn-Off
		-100V to -40V	
90ms	Ignition Pulse, Battery Disconnected	<0.5J	<500Hz Several Times in Vehicle Life
		<75V	
1ms	Mutual Coupling in Harness	<1J	Often
		<200V	
15 μ s	Ignition Pulse, Normal	<0.001J	<500Hz Continuous
		3V	
	Accessory Noise	<1.5V	50Hz to 10kHz
	Transceiver Feedback	$\approx 20mV$	R.F.
50ns	ESD	<10mJ	Infrequent/ Random
		15kV	

Extension of Contact Life

When relays or mechanical switches are used to control inductive loads, it is often necessary to derate the contacts to 50% of their resistive load rating due to the wear caused by the arcing of the contacts. This arcing is caused by the stored energy in the inductive load. Each time the current in the inductive coil is interrupted by the mechanical contacts, the voltage across the contacts increases until the contacts arc. When the contacts arc, the voltage across the arc decreases and the current in the coil can increase somewhat. The extinguishing of the arc causes an additional voltage transient which can again cause the contacts to arc. It is not unusual for restriking to occur several times with the total energy in the arc several times that which was originally stored in the inductive load. It is this repetitive arcing that is so destructive to the contacts. An ML can be used to prevent initiation of the arc.

Knowing the energy absorbed per pulse, the pulse repetition rate and the maximum operating voltage is sufficient to select the correct size ML suppressor. It is necessary to ensure that the device selected is capable of dissipating the power generated in the coil [9].

The part number of the ML device gives the following basic information:

Description of ML Ratings and Characteristics

Maximum Continuous DC Working Voltage ($V_{M(DC)}$): This is the maximum continuous DC voltage which may be applied up to the maximum operating temperature ($125^{\circ}C$) of the ML. This voltage is also used as the reference test point for leakage current. This voltage is always less than the breakdown voltage of the device.

Maximum Continuous AC RMS Working Voltage

($V_{M(AC)}$): This is the maximum continuous sinusoidal RMS voltage which may be applied. This voltage may be applied at any temperature up to $125^{\circ}C$.

Maximum Non-Repetitive Surge Current (I_{TM}): This is the maximum peak current which may be applied for an 8/20 μs impulse (Figure 15), with the $V_{M(DC)}$ or $V_{M(AC)}$ voltage also applied, without causing device failure. This pulse can be applied to the ML suppressor in either polarity.

Maximum Non-Repetitive Surge Energy (W_{TM}): This is the maximum rated transient energy which may be dissipated for a single current pulse of 10/1000 μs , with the rated $V_{M(DC)}$ or $V_{M(AC)}$ voltage applied, without causing device failure.

Maximum Clamping Voltage (V_C): This is the peak voltage appearing across the ML suppressor when measured for an 8/20 μs impulse and specified pulse current. The clamping voltage is shown for a current range of 1mA to 50A in the maximum transient V-I characteristic curves.

Leakage Current (I_L): This is the amount of current drawn by the ML in its non-operational mode, i.e., when the voltage applied across the ML does not exceed the rated $V_{M(DC)}$ or $V_{M(AC)}$ voltage.

Nominal Voltage ($V_{N(DC)}$): This is the voltage at which the ML begins to enter its conduction state and suppress transients. This is the voltage defined at the 1mA point and has a minimum and maximum voltage specified.

Capacitance (C): This is the capacitance of the ML when measured at a frequency of 1MHz with 1V_{P-P} voltage bias applied.

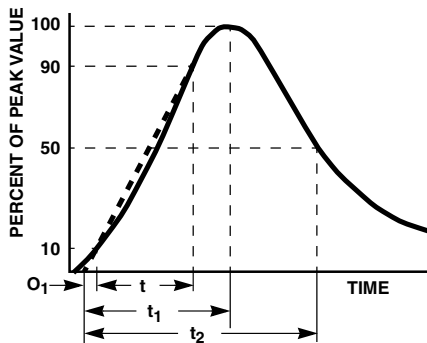

- O_1 = Virtual Origin of Wave
- T = Time From 10% to 90% of Peak
- T_1 = Virtual Front time = $1.25 \cdot t$
- T_2 = Virtual Time to Half Value (Impulse Duration)

Example: For an 8/20 μs Current Waveform:
 $8\mu s = T_1$ = Virtual Front Time
 $20\mu s = T_2$ = Virtual Time to Half Value

FIGURE 15. CURRENT TEST WAVEFORM

Ordering Information

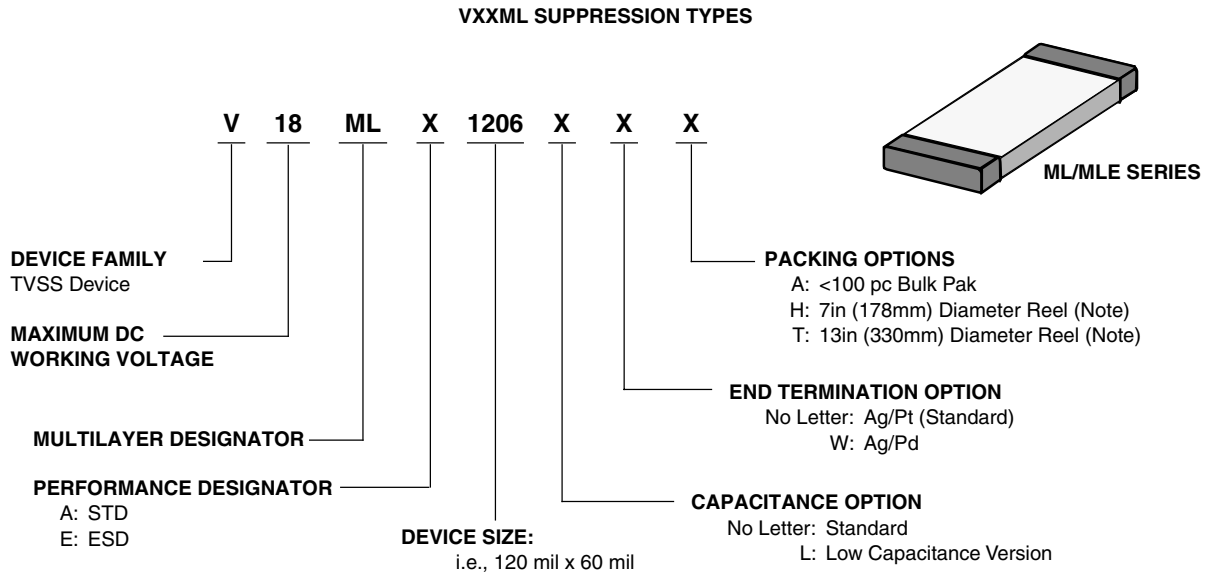

NOTE: Quantity per reel depends upon device size.

Soldering Recommendations

The principal techniques used for the soldering of components in surface mount technology are Infra Red (IR) Reflow, Vapour Phase Reflow, and Wave Soldering. When wave soldering, the ML suppressor is attached to the circuit board by means of an adhesive. The assembly is then placed on a conveyor and run through the soldering process to contact the wave. With IR and Vapour Phase Reflow, the device is placed in a solder paste on the substrate. As the solder paste is heated, it reflows and solders the unit to the board.

With the ML suppressor, the recommended solder is a 62/36/2 (Sn/Pb/Ag), 60/40 (Sn/Pb), or 63/37 (Sn/Pb). Littelfuse also recommends an RMA solder flux.

Wave soldering is the most strenuous of the processes. To avoid the possibility of generating stresses due to thermal shock, a preheat stage in the soldering process is recommended, and the peak temperature of the solder process should be rigidly controlled.

When using a reflow process, care should be taken to ensure that the ML chip is not subjected to a thermal gradient steeper than 4 degrees per second; the ideal gradient being 2 degrees per second. During the soldering process, preheating to within 100 degrees of the solders peak temperature is essential to minimize thermal shock. Examples of the soldering conditions for the ML series of suppressors are given in the tables below.

Once the soldering process has been completed, it is still necessary to ensure that any further thermal shocks are avoided. One possible cause of thermal shock is hot printed

circuit boards being removed from the solder process and subjected to cleaning solvents at room temperature. The boards must be allowed to gradually cool to less than 50°C before cleaning.

Termination Options

Littelfuse offers two types of electrode termination finish for the Multilayer product series:

1. Silver/Platinum (standard).
2. Silver/Palladium (optional).

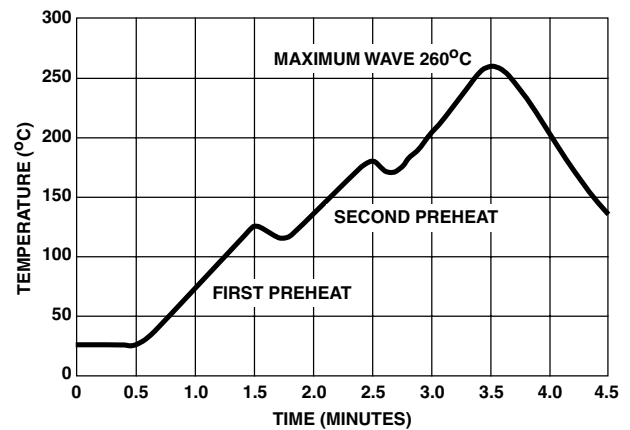

FIGURE 16. WAVE SOLDER PROFILE

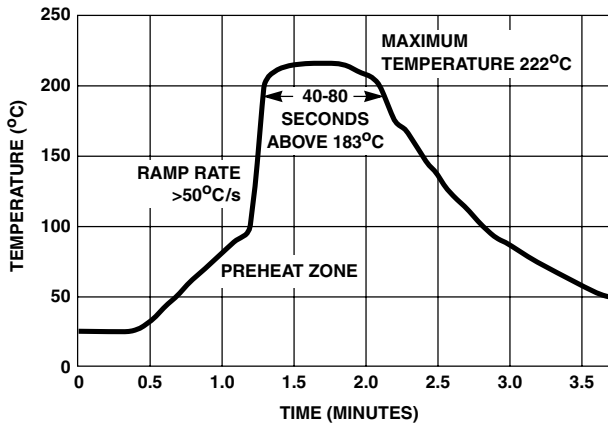

FIGURE 17. VAPOR PHASE SOLDER PROFILE

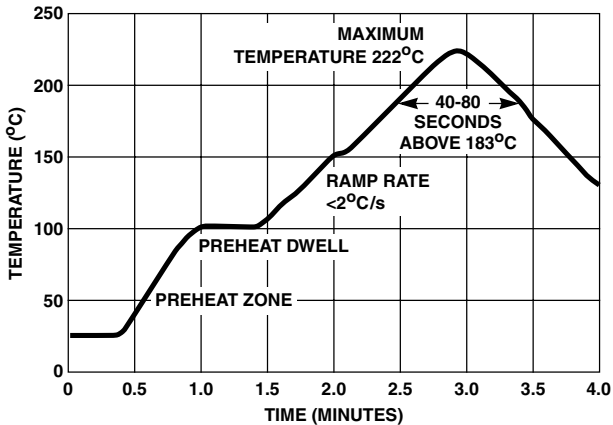

FIGURE 18. REFLOW SOLDER PROFILE

References

For Littelfuse documents available on the internet, see web site <http://www.littelfuse.com/>

- [1] "An Overview of Electrical Overstress Effects on Semiconductor Devices," D.G. Pierce and D.L. Durgin, Booz-Allen & Hamilton, Inc., Albuquerque, NM.
- [2] "The Low-Voltage Metal-Oxide Varistor - Protection for Low Voltage ($\leq 5V$) ICs", Application Note AN9003.
- [3] "Protection of Electronic Circuits From Overvoltages", Ronald B. Standler, 1989.
- [4] "ZnO Varistors for Transient Protection," L.M. Levinson, and H.R. Phillip, IEEE Trans. Parts, Hybrids and Packaging, 13:338-343, 1977.
- [5] "ZnO Varistors for Protection Against Nuclear Electromagnetic Pulses," H.R Phillip, and L.M. Levinson, 1981.
- [6] "Overshoot: A Lead Effect in Varistor Characteristics," Fisher, F.A., G.E. Company, Schenectady, NY, 1978.
- [7] "The Connector Pin Varistor for Transient Voltage Protection in Connectors", Paul McCambridge and Martin Corbett, Application Note AN9307.
- [8] "Suppression of Transients in an Automotive Environment", Martin Corbett, Application Note AN9312.
- [9] "Transient Voltage Suppression Devices", Harris Suppression Products DB450.