

Introduction

The purpose of the International Electrotechnical Commission IEC 1000-4 (previously known as IEC-801) standard is to establish a common reference for evaluating the performance of industrial-process measurement and control instrumentation when exposed to electric or electromagnetic interference. The types of interference considered are those arising from sources external to the equipment.

The interference susceptibility tests are essentially designed to demonstrate the capability of equipment to function correctly when installed in its working environment. The type of test required should be determined on the basis of the interference to which the equipment may be exposed when installed while taking into consideration the electrical circuit (i.e., the way the circuit and shields are tied to earth ground), the quality of shielding applied, and the environment in which the system is required to work.

The IEC 1000-4 standard is divided into six sections:

- IEC 1000-4-1.** Introduction
- IEC 1000-4-2.** Electrostatic Discharge Requirements
- IEC 1000-4-3.** Radiated Electromagnetic Field Requirements
- IEC 1000-4-4.** Electrical Fast Transient (Burst) Requirements
- IEC 1000-4-5.** Surge Voltage Immunity Requirements
- IEC 1000-4-6.** Immunity to Conducted Disturbances Induced by Radio Frequency Fields Above 9kHz

Sections IEC 1000-4-2 through IEC 1000-4-5 will be discussed in this application note.

TEST SEVERITY LEVEL

LEVEL	TEST VOLTAGE: CONTACT DISCHARGE	TEST VOLTAGE: AIR DISCHARGE
1	2kV	2kV
2	4kV	4kV
3	6kV	8kV
4	8kV	15kV
X	Special	Special

NOTES:

1. "X" is an open level.
2. The test severity levels shall be selected in accordance with the most realistic installation and environmental conditions.

Electrostatic Discharge (ESD) Requirements

The purpose of this test is to find the reaction of the equipment when subjected to electrostatic discharges which may occur from personnel to objects near vital instrumentation.

In order to test the equipment's susceptibility to ESD, the test setup conditions must be established. Direct and indirect application of discharges to the Equipment Under Test (EUT) are possible, in the following manner:

- a) Contact discharges to the conductive surfaces and to coupling planes.
- b) Air discharge at insulating surfaces.

Two different types of tests can be conducted:

1. Type (conformance) tests performed in laboratories.
2. Post installation tests performed on equipment in its installed conditions.

CHARACTERISTICS OF THE ESD GENERATOR

LEVEL	INDICATED VOLTAGE	FIRST PEAK CURRENT OF DISCHARGE ($\pm 10\%$)	RISE TIME WITH DISCHARGE SWITCH	CURRENT AT 30ns ($\pm 30\%$)	CURRENT AT 60ns ($\pm 30\%$)
1	2kV	7.5A	0.7 to 1ns	4A	2A
2	4kV	15A	0.7 to 1ns	8A	4A
3	6kV	22.5A	0.7 to 1ns	12A	6A
4	8kV	30A	0.7 to 1ns	16A	8A

Application Note 9734

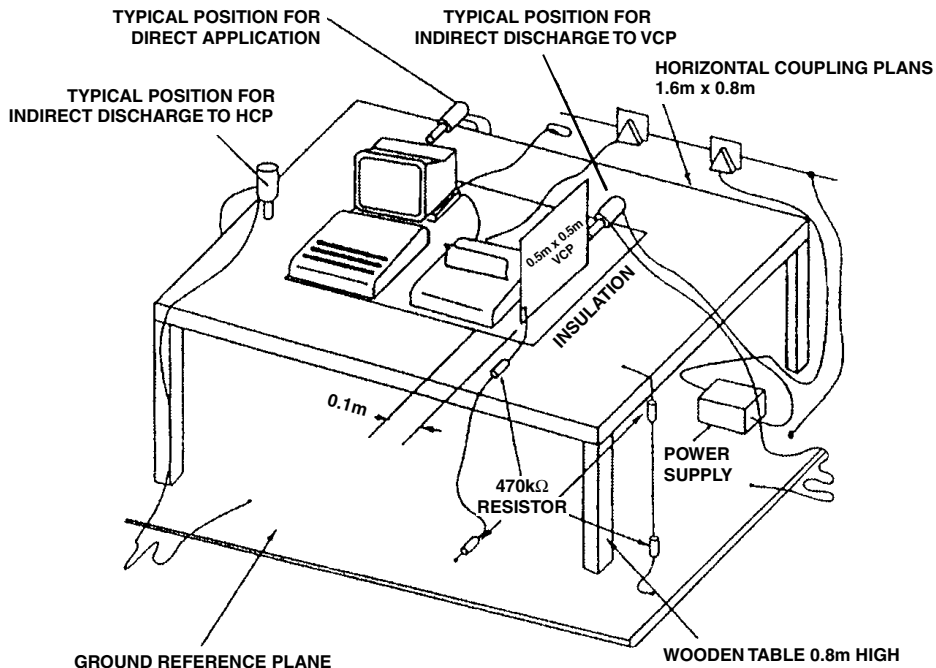

FIGURE 1. EXAMPLE OF TEST SETUP FOR TABLETOP EQUIPMENT, LABORATORY TESTS

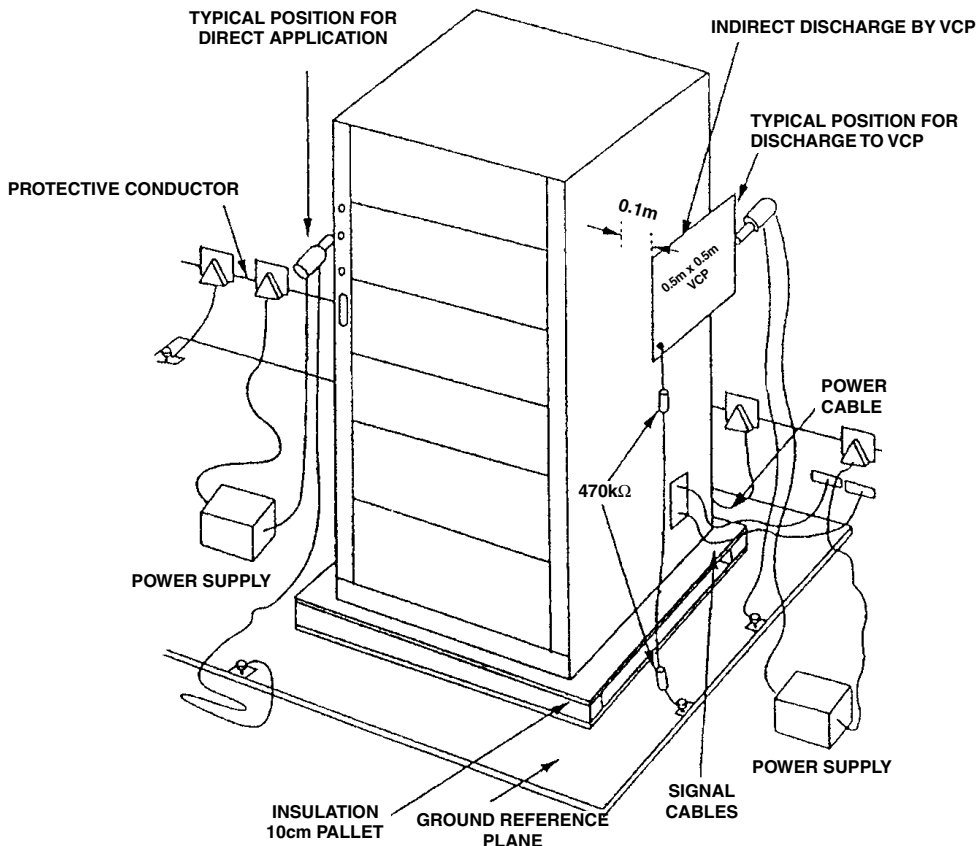

FIGURE 2. EXAMPLE OF TEST SETUP FOR FLOOR STANDING EQUIPMENT, LABORATORY TESTS

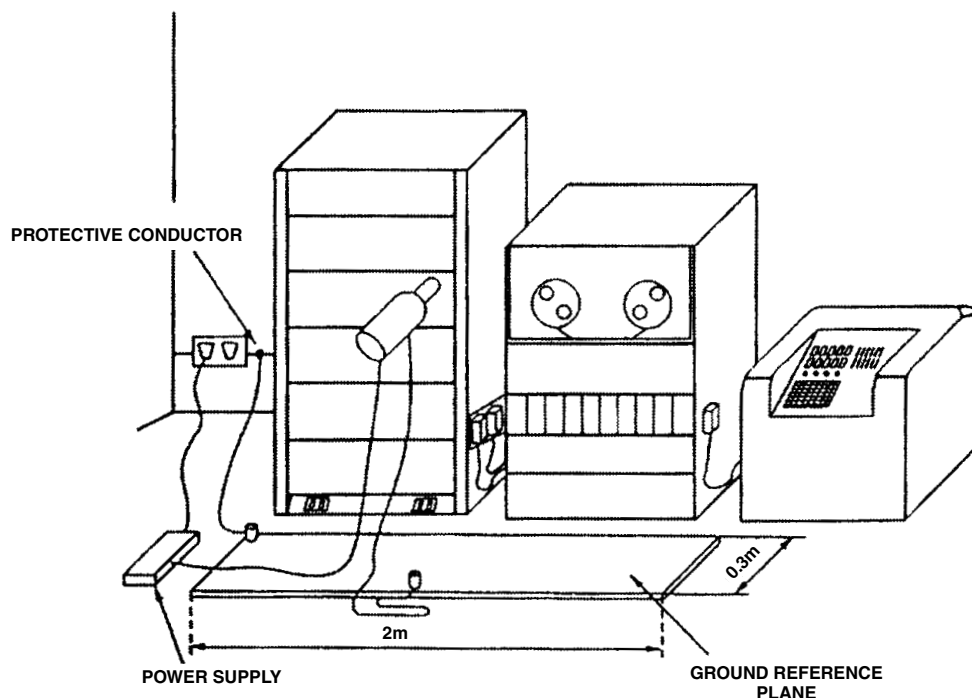

FIGURE 3. EXAMPLE OF TEST SETUP FOR EQUIPMENT, POST-INSTALLATION TESTS

The only accepted method of demonstrating conformance to the standard is the of type tests performed in laboratories. The EUT, however, shall be arranged as closely as possible to the actual installation conditions.

Examples of laboratory ESD test setups can be seen in Figure 1 for tabletop equipment and in Figure 2 for floor standing equipment.

Post installation tests are optional and not mandatory for certification. If a manufacturer and customer agree post installation tests are required, a typical test setup can be found in Figure 3.

Test Procedure

- For conformance testing, the EUT shall be continually operated in its most sensitive mode which shall be determined by preliminary testing.
- The test voltage shall be increased from the minimum to the selected test severity level.
- Number: at least 10 single discharges (in the most sensitive polarity).
- Time interval: initial value 1 second, longer intervals may be necessary.
- Direct application of discharge to the EUT: The static electricity discharges shall be applied only to those points

and surfaces of the EUT which are accessible to the human operator during normal usage.

- Indirect application of the discharge: Discharges to objects placed or installed near the EUT shall be simulated by applying the discharges to a coupling plane (a horizontal coupling plane under the EUT or a vertical coupling plane).

Test Results

The results of the ESD tests are reported as follows:

1. Normal performance within the specification limits.
2. Temporary degradation or loss of function or performance which is self-recoverable.
3. Temporary degradation or loss of function or performance which requires operator intervention or system reset.
4. Degradation or loss of function which is not recoverable, due to damage of equipment (component) or software, or loss of date.

IEC 1000-4-3

Radiated Electromagnetic Field Requirements

This test shows the susceptibility of instrumentation when subjected to electromagnetic fields such as those generated by portable radio transceivers or any other device that will generate continuous wave (CW) radiated electromagnetic energy.

Application Note 9734

TEST SEVERITY LEVELS

Frequency band: 27MHz to 500MHz

LEVEL	TEST FIELD STRENGTH (V/M)
1	1
2	3
3	10
X	Special

NOTES:

3. "X" is an open class.
4. The test severity levels shall be selected in accordance with the electromagnetic radiation environment to which the EUT may be exposed when finally installed.

Test Setup

Examples of the test configuration for radiated electromagnetic fields can be found in Figure 4 and Figure 5.

- The procedure requires the generation of electromagnetic fields within which the test sample is placed and its operation observed. The tests shall be carried out in a shielded enclosure or anechoic chamber. The test procedure assumes the use of biconical and log-spiral antennae or stripline.
- All testing of the equipment shall be performed in conditions as close as possible to the actual installation.

Small objects (25cm x 25cm x 25cm) can be tested using a stripline antennae. This is a parallel plate transmission line to generate an electromagnetic field as shown in Figure 6.

Test Procedure

- The test is performed with the EUT in the most sensitive physical orientation.
- The frequency range is swept from 27 MHz to 500 MHz. The sweep rate is in the order of 1.5×10^{-3} decades/s.

Test Results

The results of the radiated electromagnetic field include:

- The effect of the electromagnetic field on the output of the EUT
 - As a consistent measurable effect.
 - As a random effect, not repeatable, and possibly further classified as a transient effect occurring during the application of the electromagnetic field and as a permanent or semipermanent field after the application of the electromagnetic field.
- Any damage to the EUT resulting from the application of the electromagnetic field.

The qualitative evaluation of the resultant data needs to be assessed in terms of the existing local ambient electromagnetic level and the specific operating frequencies.

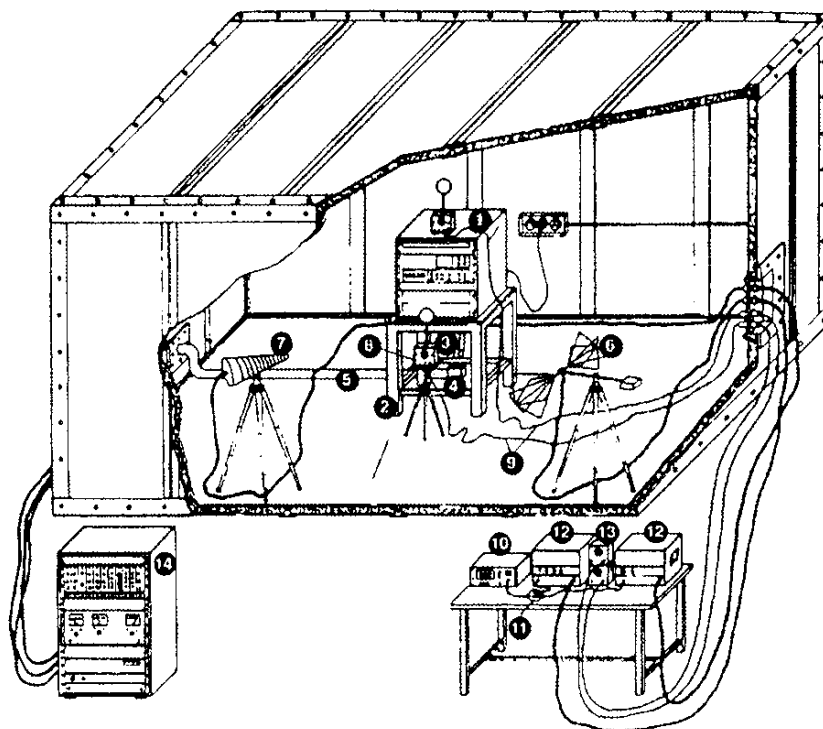

FIGURE 4. TEST SETUP FOR RADIATED ELECTROMAGNETIC FIELD TESTS IN A SHIELDED ROOM WHERE THE ANTENNAE, FIELD STRENGTH MONITORS AND EUT ARE INSIDE AND THE MEASURING INSTRUMENTS AND ASSOCIATED EQUIPMENT ARE OUTSIDE THE SHIELDED ROOM

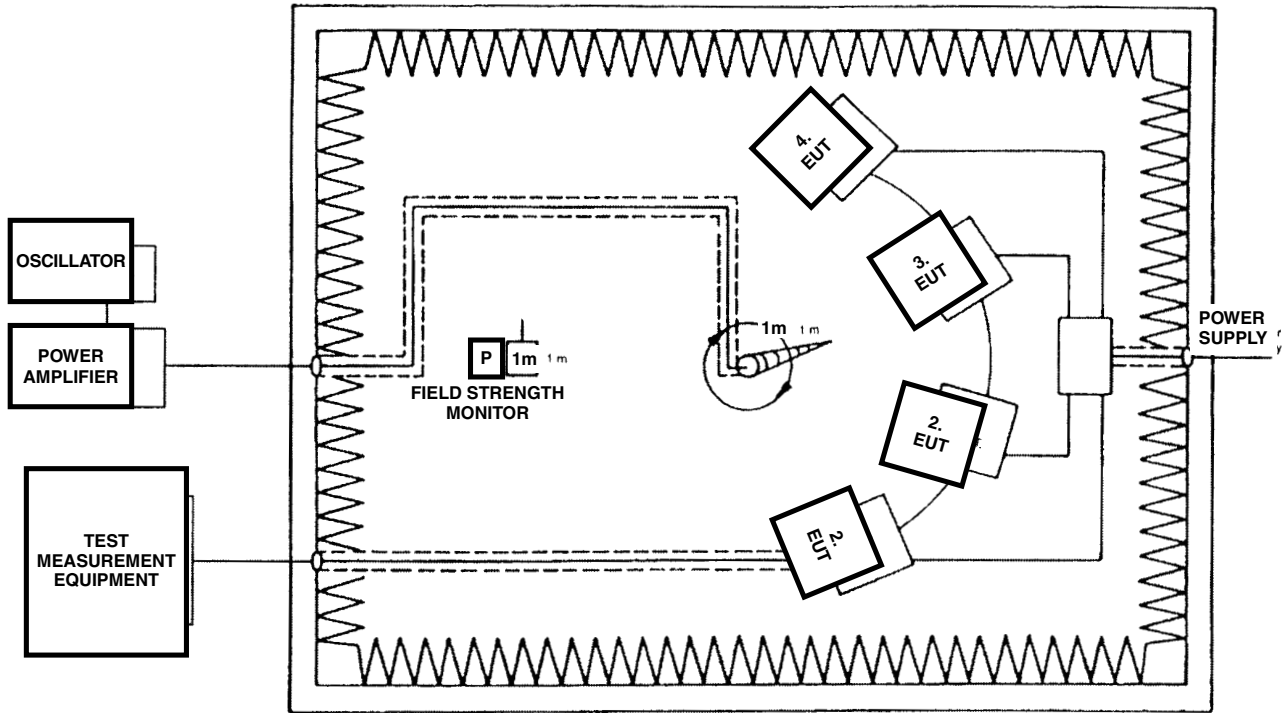
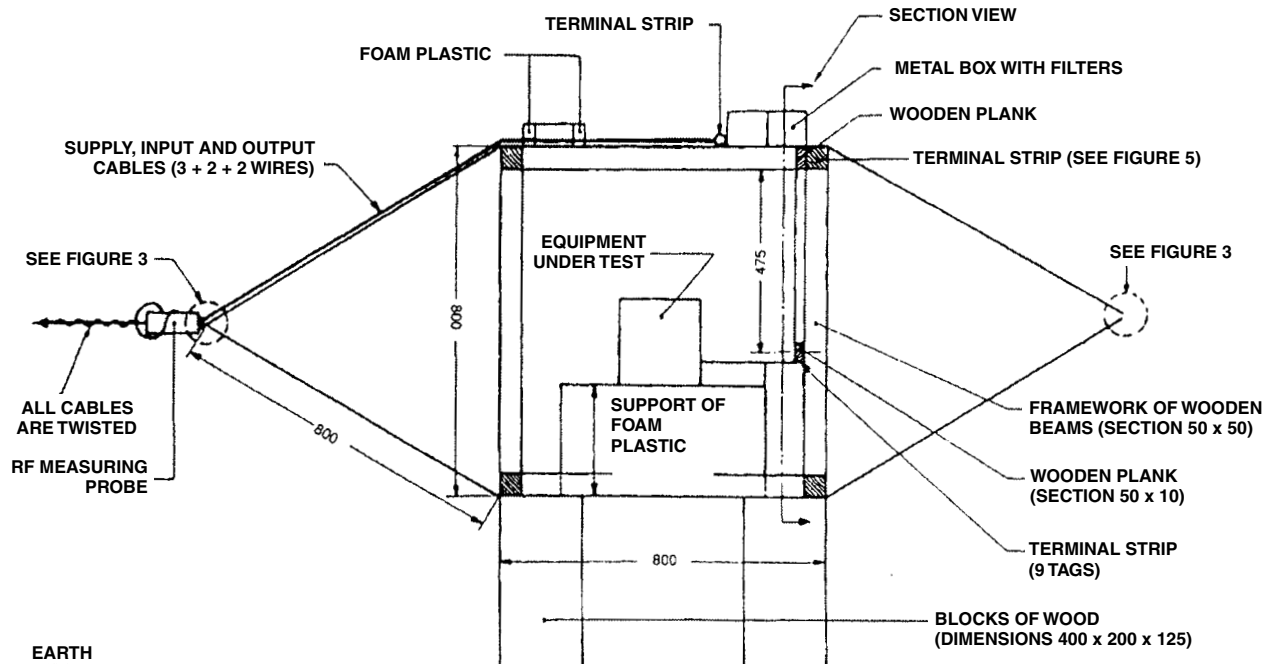

FIGURE 5. TEST SETUP FOR RADIATED ELECTROMAGNETIC FIELD TESTS IN AN ANECHOIC CHAMBER, GENERAL ARRANGEMENT OF THE EUT, FIELD STRENGTH MONITOR AND ANTENNAE



NOTE: Dimensions in millimeters.

FIGURE 6. TEST SETUP WITH STRIPLINE CIRCUIT

IEC 1000-4-4

Electrical Fast Transient (Burst) Requirements

This test is intended to demonstrate the immunity of the equipment when subjected to interference originating from switching transients.

TEST SEVERITY LEVELS

Open circuit output test voltage:

LEVEL	ON POWER SUPPLY	ON INPUT/OUTPUT SIGNAL DATA AND CONTROL LINES
1	0.5kV	0.25kV
2	1kV	0.5kV
3	2kV	1kV
4	4kV	2kV
X	Special	Special

NOTES:

- 5. "X" is an open level.
- 6. The test severity levels shall be selected in accordance with the most realistic installation and environmental conditions.

Characteristics of the Fast Transient/Burst Generator

- Rise time of one pulse: 5ns ±30%
- Impulse duration (50% value): 50ns ±30%
- Repetition rate of the impulses and peak values of the output voltage:
 5kHz ±20% at 0.125kV
 5kHz ±20% at 0.25kV
 5kHz ±20% at 0.5kV
 5kHz ±20% at 1.0kV
 5kHz ±20% at 2.0kV
- Burst duration: 15ms ±20%
- Burst period: 300ms ±20%

Test Setup

For laboratory testing, the test setup for type testing can be shown in Figure 7 and Figure 8.

- Power supply lines (See Figure 7): If the line current is higher than 100A, the "field test" shall be used.
- Earth connections of the cabinets: The test point on the cabinet shall be the terminal for the protective earth conductor (See Figure 7).
- Input/Output circuits and communication lines (See Figure 8).

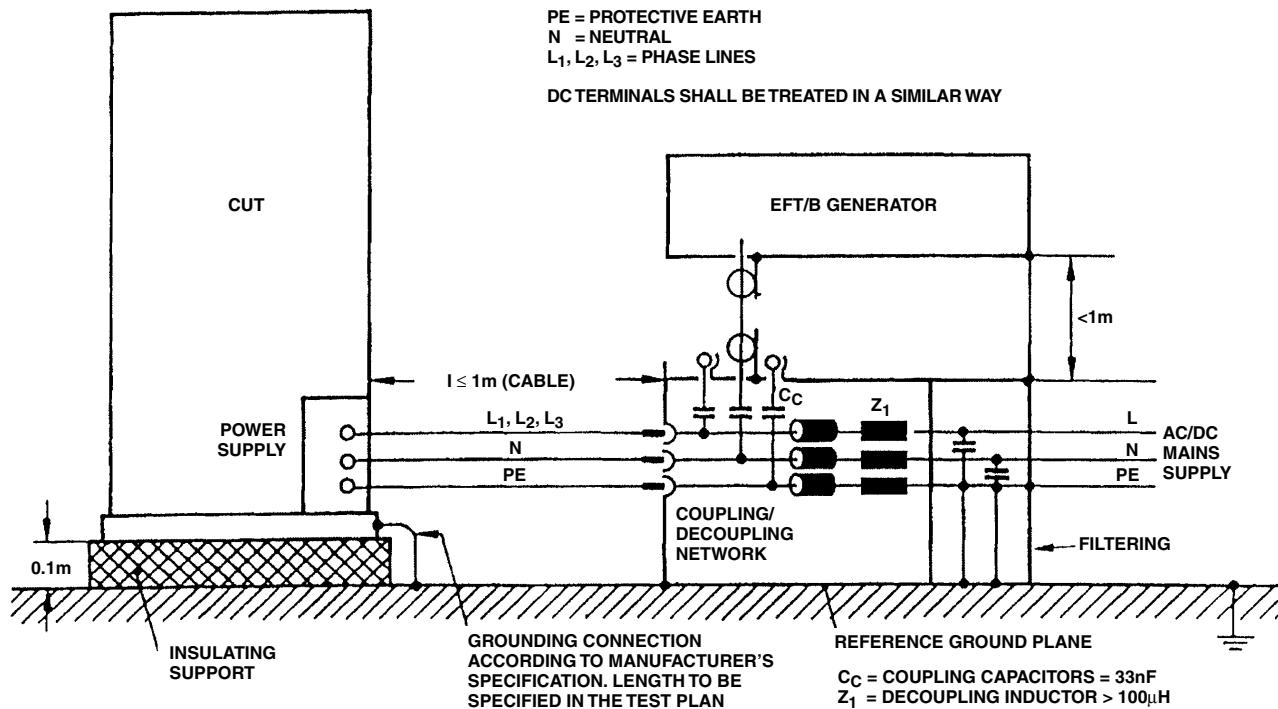

FIGURE 7. EXAMPLE OF TEST SETUP FOR DIRECT COUPLING OF THE TEST VOLTAGE TO AC/DC POWER SUPPLY LINES/TERMINALS FOR LABORATORY TEST PURPOSES

IEC 1000-4-4

Electrical Fast Transient (Burst) Requirements

For field testing, the equipment or system shall be tested in the final installed conditions without coupling/decoupling networks.

- Power supply lines and protective earth terminals
 - Stationary, floor-mounted EUT: The test voltage shall be applied between a reference ground plane and each of

the power supply terminals, AC or DC, and on the terminals for the protective or function earth on the cabinet of the EUT. (See Figure 9).

- Non-stationary mounted EUT, connected to the mains supply by flexible cord and plugs: The test voltage shall be applied between each of the power supply conductors and the protective earth at the power supply outlet to which the EUT is to be connected. (See Figure 10).

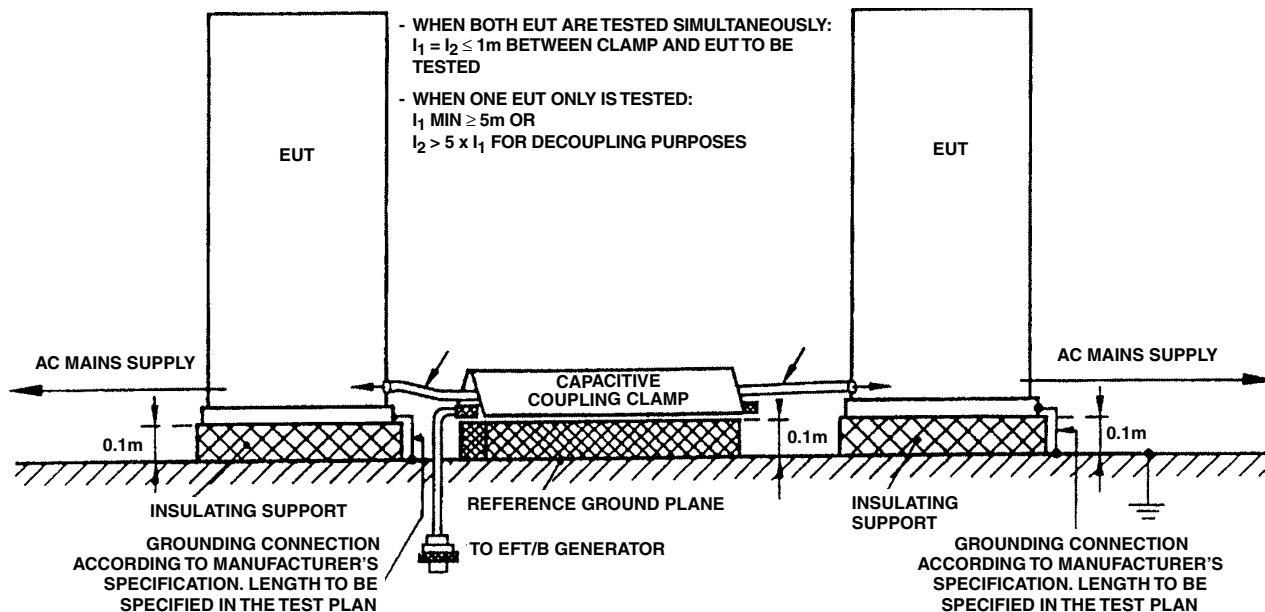
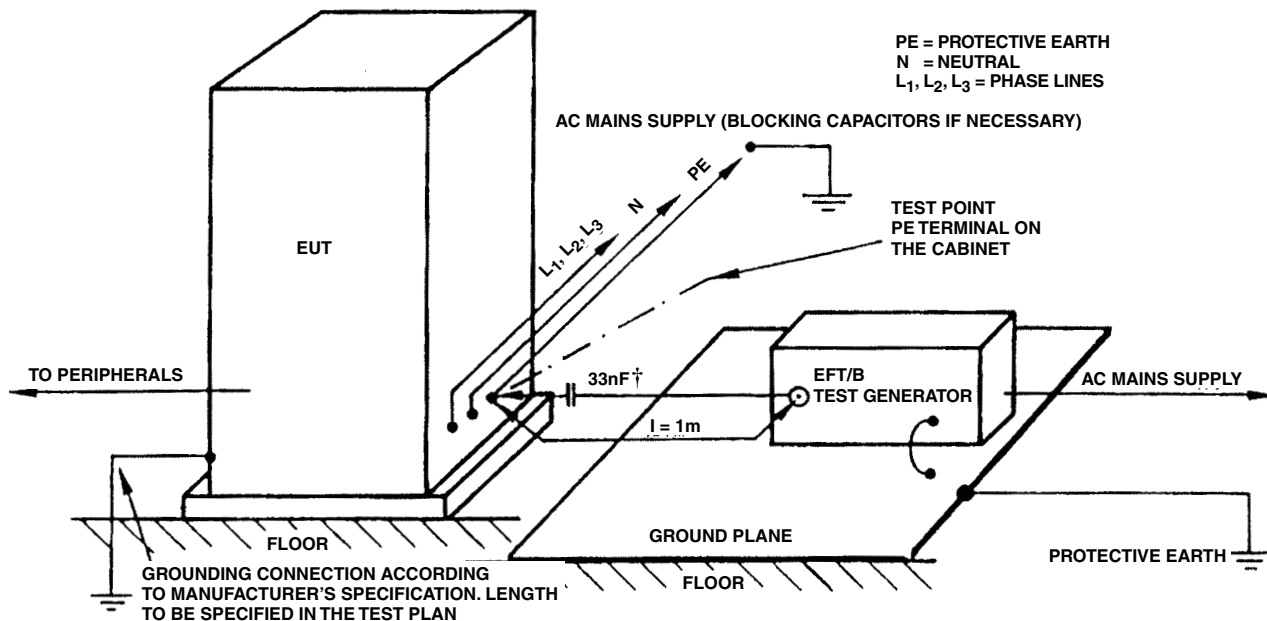

FIGURE 8. EXAMPLE OF TEST SETUP FOR APPLICATION OF THE TEST VOLTAGE BY THE CAPACITIVE COUPLING CLAMP FOR LABORATORY TEST PURPOSES



†DC terminals shall be treated in a similar way.

FIGURE 9. EXAMPLE OF FIELD TEST ON AC/DC POWER SUPPLY LINES AND PROTECTIVE EARTH TERMINALS FOR STATIONARY, FLOOR MOUNTED EUT

Application Note 9734

- Input/Output circuits and communication lines:
 - A capacitive clamp shall be used for coupling the test voltage into the lines. However, if the clamp cannot be used due to mechanical problems in the cabling, it may be replaced by a tape or a conductive foil enveloping the lines under test. (See Figure 11).

Test Procedure

- Polarity of the test voltage: both polarities are mandatory
- Duration of the test: at least 1 minute

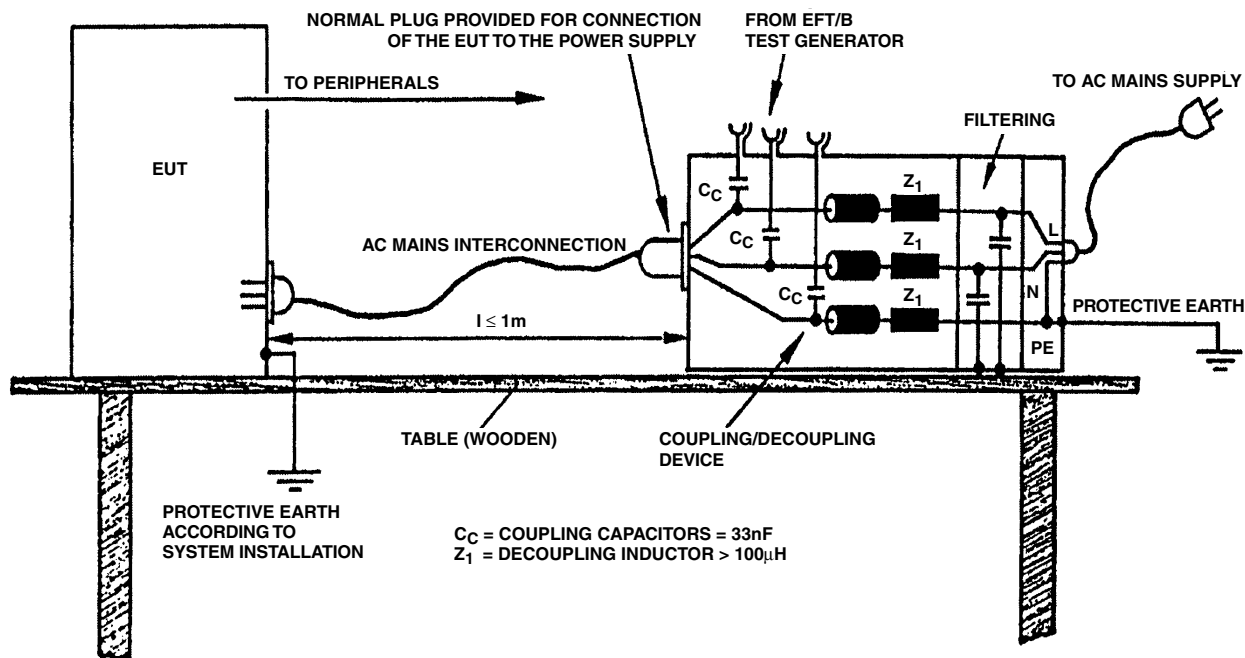

FIGURE 10. EXAMPLE OF FIELD TEST ON AC MAINS SUPPLY AND PROTECTIVE EARTH TERMINALS FOR NON-STATIONARY MOUNTED EUT

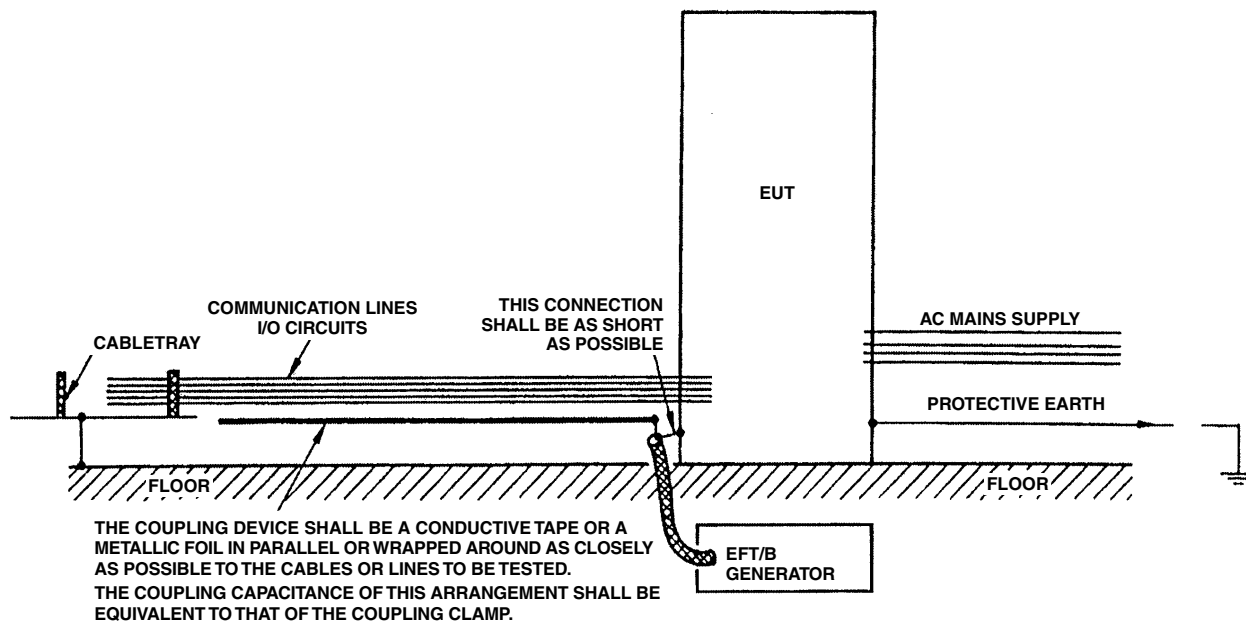

FIGURE 11. EXAMPLE OF FIELD TEST ON COMMUNICATIONS AND I/O CIRCUITS WITHOUT THE CAPACITIVE COUPLING CLAMP

Application Note 9734

Test Results

The results are reported as:

1. Normal performance within the specification limits.
2. Temporary degradation or loss of function or performance which is self-recoverable.
3. Temporary degradation or loss of function or performance which requires operator intervention or system reset.
4. Degradation or loss of function which is not recoverable, due to damage of equipment (component) or software, or loss of data.

IEC 1000-4-5

Surge Voltage Immunity Requirements

The goal of the laboratory test is to determine the equipment's susceptibility to damage caused by overvoltage surges caused by circuit switching and lightning strikes.

TEST SEVERITY LEVELS

CLASS	POWER SUPPLY		UNSYM LINES LONG DATA BUS		SYMMETRICAL LINES	DATA BUS SHORT (DIST)
	LINE TO LINE Z = 2	LINE TO GROUND Z = 12	LINE TO LINE Z = 42	LINE TO GROUND Z = 42	LINE TO GROUND Z = 42	LINE TO GROUND
0	No Test is Advised					
1	-	0.5kV	-	0.5kV	1.0kV	-
2	0.5kV	1.0kV	0.5kV	1.0kV	1.0kV	0.5kV
3	1.0kV	2.0kV	1.0kV	2.0kV	2.0kV	-
4	2.0kV	4.0kV	2.0kV	4.0kV	-	-
5	(Note 8)	(Note 8)	2.0kV	4.0kV	4.0kV	-
X	Special					

NOTES:

7. Z is the source impedance.
8. Depends on the class of the local power supply system. "X" is an open level that has to be specified in the product specification. The class depends on the installation conditions.

Characteristics of the Test Instrumentation

- Combination wave test generator
 - Open circuit output voltage 0.5kV to 4.0kV
 - Short circuit output current 0.25kA to 2.0kA
- Test generator 10/700 μ s (according to CCITT):
 - Open circuit output voltage 0.5kV to 4.0kV
 - Short circuit output current 12.5A to 100A

	IN ACCORDANCE WITH IEC60-2		IN ACCORDANCE WITH IEC469-1	
	FRONT TIME	TIME TO HALF VALUE	RISE TIME (10%-90%)	DURATION (50%-50%)
Open Circuit Voltage	1.2 μ s	50 μ s	1 μ s	50 μ s
Short Circuit Current	8 μ s	20 μ s	6.4 μ s	16 μ s

	IN ACCORDANCE WITH IEC60-2		IN ACCORDANCE WITH IEC469-1	
	FRONT TIME	TIME TO HALF VALUE	RISE TIME (10%-90%)	DURATION (50%-50%)
Open Circuit Voltage	10 μ s	700 μ s	6.5 μ s	700 μ s
Short Circuit Current	-	-	4 μ s	300 μ s

NOTE: The surges (and test generators) related to the different classes are:
 Class 1 to 4: 1.2/50 μ s (8/20 μ s)
 Class 5: 1.2/50 μ s (8/20ms) and 10/700 μ s

Test Setup

A decoupling network is used to prevent surge energy from being propagated to the other equipment operating from the same source during testing of the EUT. The test setup for evaluating the EUT power supply is shown in Figures 12 - 15. A capacitive coupling network (preferred) or an inductive coupling network is used for this test.

The test setup for evaluating the unshielded interconnection lines of the EUT is illustrated in Figures 16-20. Usually, capacitive coupling is used, but inductive coupling or coupling via gas discharge tube (GDT) surge arrestors is also possible.

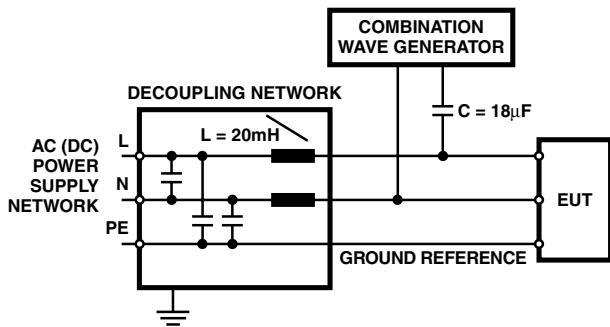

FIGURE 12. TEST SETUP FOR CAPACITIVE COUPLING ON AC/DC LINES; LINE TO LINE COUPLING ACCORDING TO 7.2

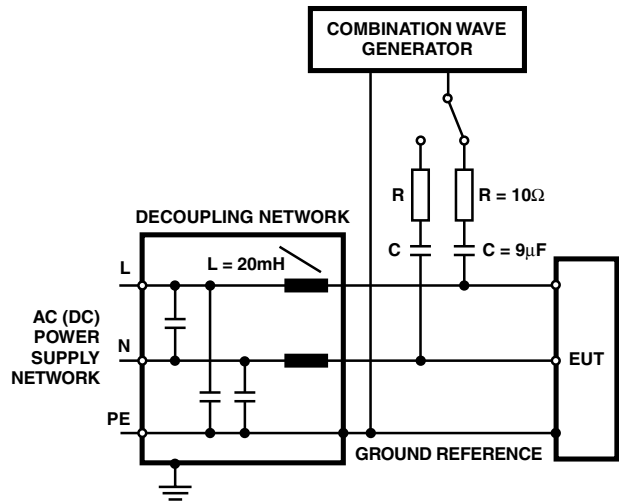

FIGURE 13. TEST SETUP FOR CAPACITIVE COUPLING ON AC/DC LINES; LINE TO GROUND COUPLING ACCORDING TO 7.2 (GENERATOR OUTPUT FLOATING OR EARTHED)

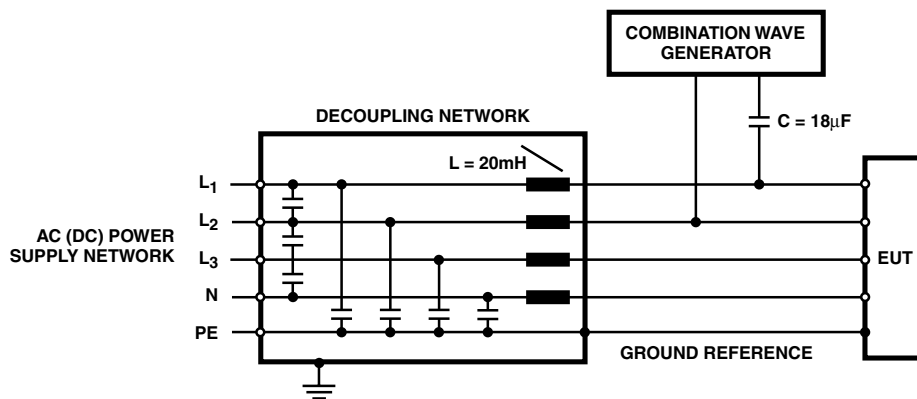

FIGURE 14. TEST SETUP FOR CAPACITIVE COUPLING ON AC LINES (3 PHASES); LINE TO LINE COUPLING ACCORDING TO 7.2

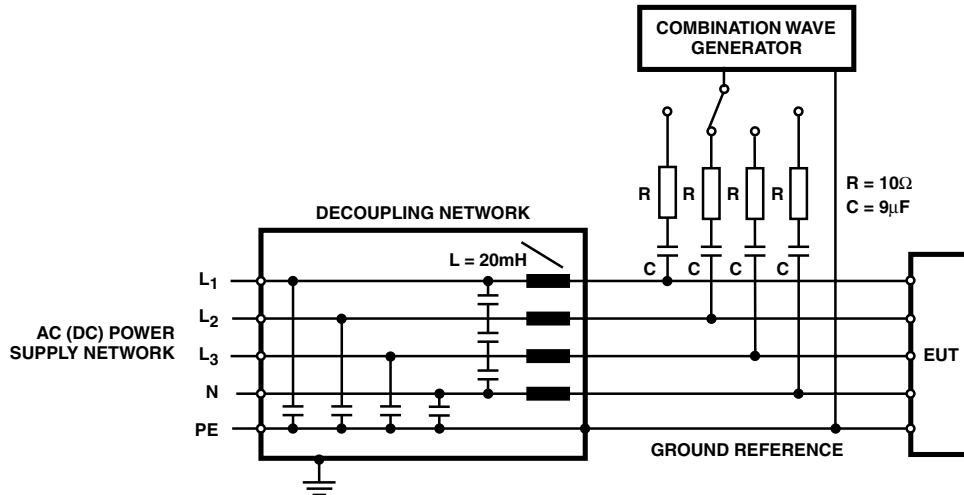

FIGURE 15. TEST SETUP FOR CAPACITIVE COUPLING ON AC LINES (3 PHASES); LINE TO GROUND COUPLING ACCORDING TO 7.2

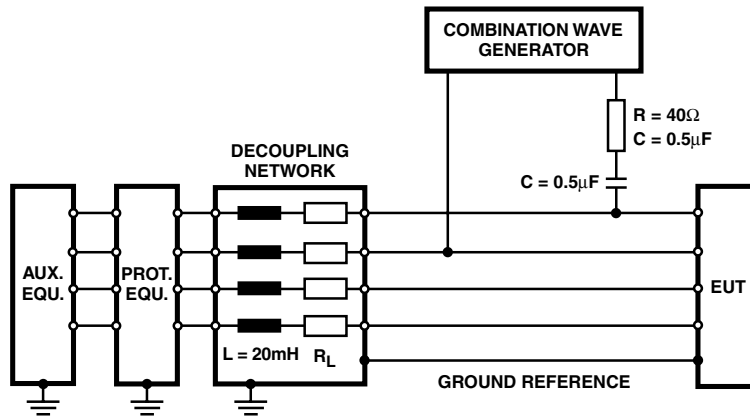

FIGURE 16. TEST SETUP FOR UNSHIELDED INTERCONNECTION LINES; LINE TO LINE COUPLING ACCORDING TO 7.3; COUPLING VIA CAPACITORS

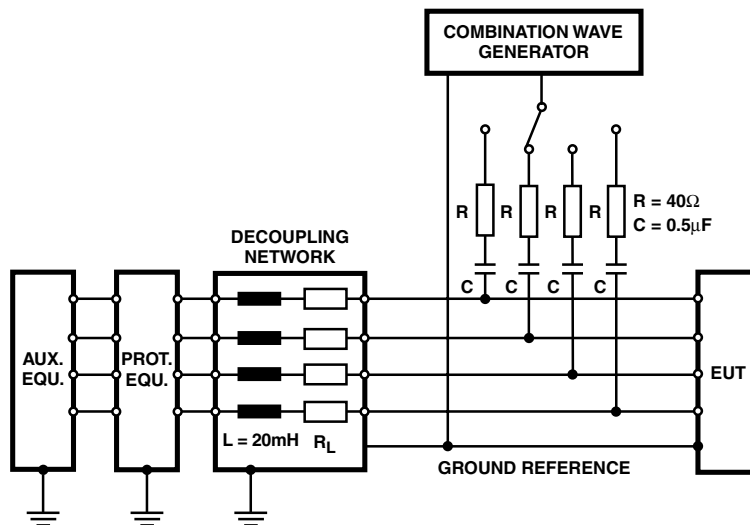

FIGURE 17. TEST SETUP FOR UNSHIELDED INTERCONNECTION LINES; LINE TO GROUND COUPLING TO 7.3; COUPLING VIA CAPACITORS

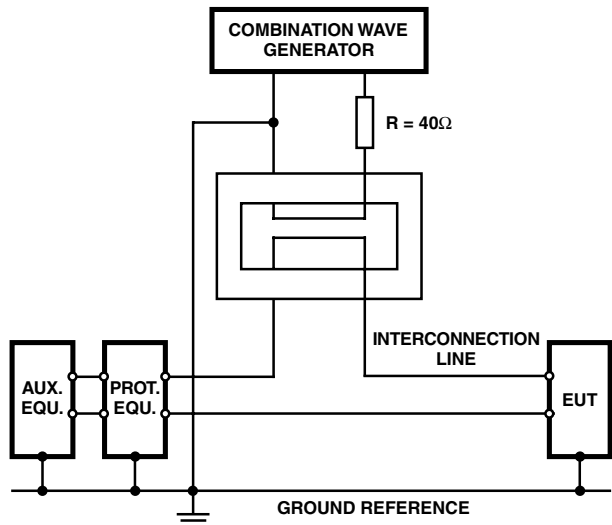

FIGURE 18. TEST SETUP FOR UNSHIELDED INTERCONNECTION LINES; LINE TO LINE COUPLING ACCORDING TO 7.3; INDUCTIVE COUPLING FOR HIGH IMPEDANCE CIRCUITS

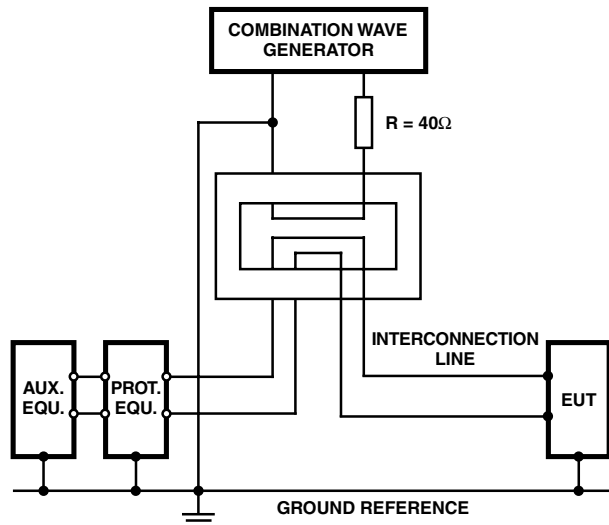

FIGURE 19. SIMPLIFIED TEST SETUP FOR UNSHIELDED INTERCONNECTION LINES; LINE TO GROUND COUPLING ACCORDING TO 7.3; INDUCTIVE COUPLING FOR LOW IMPEDANCE CIRCUITS

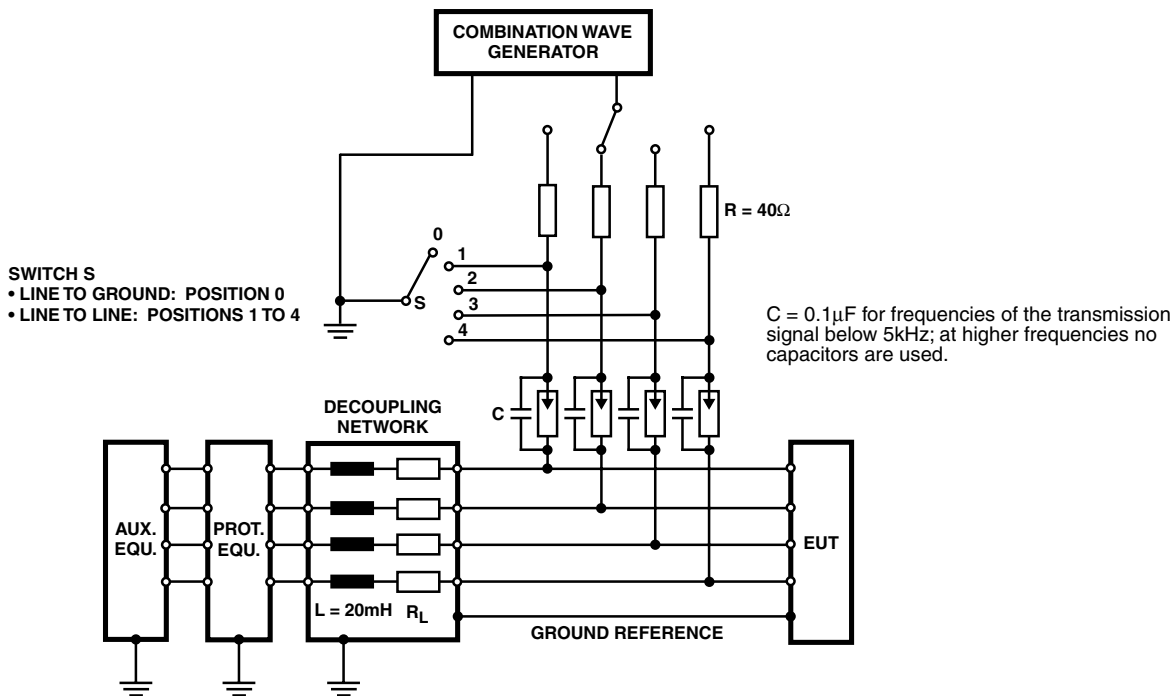

FIGURE 20. TEST SETUP FOR UNSHIELDED UNSYMMETRICALLY OPERATED LINES; LINE TO GROUND COUPLING ACCORDING TO 7.3; COUPLING VIA GAS ARRESTORS

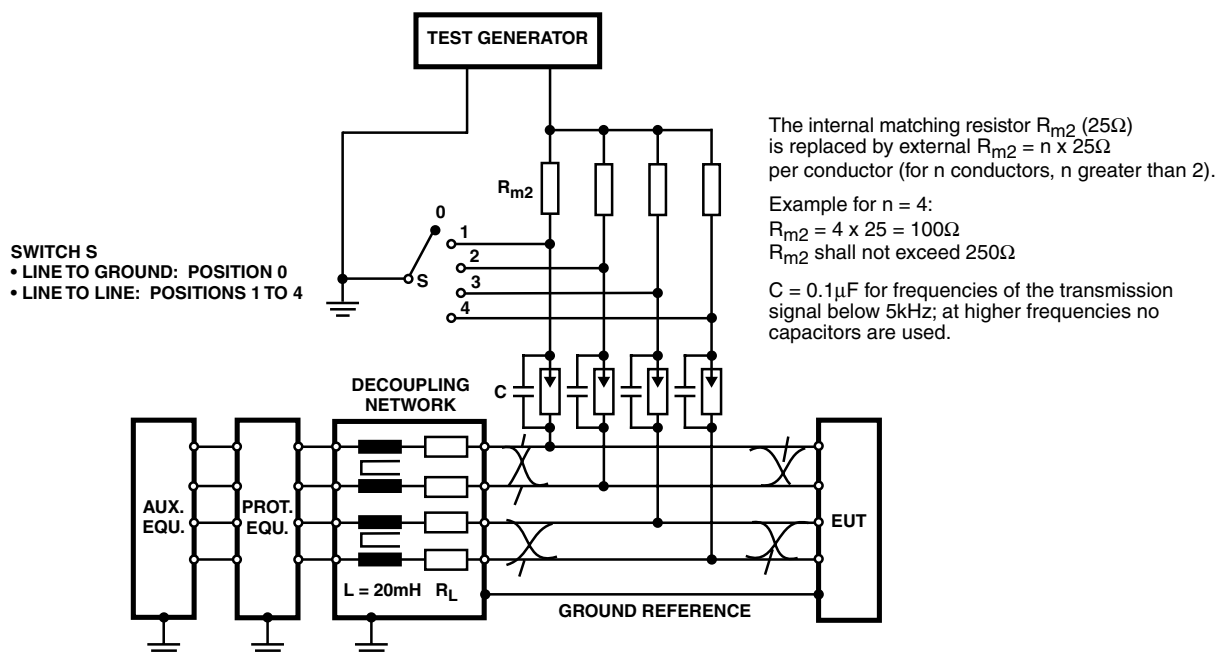

FIGURE 21. TEST SETUP FOR UNSHIELDED SYMMETRY OPERATED LINES (TELECOMMUNICATION LINES); LINE TO GROUND COUPLING ACCORDING TO 7.4; COUPLING VIA GAS ARRESTORS

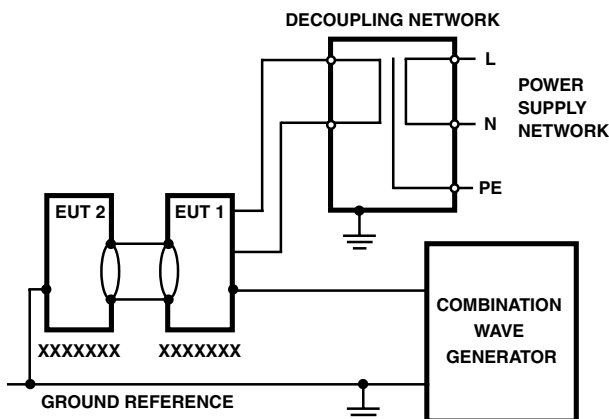

FIGURE 22. TEST SETUP FOR TESTS APPLIED TO SHIELDED LINES AND TO APPLY POTENTIAL DIFFERENCES ACCORDING TO 7.5 AND 7.6; GALVANIC COUPLING

Test Procedure

- Number of tests: at least 5 positive and 5 negative at the selected points.
- Pulse repetition: Max. 1/min.
- The maximum repetition rate depends on the built-in protection devices of the EUT.
- The surge will be applied between lines and between lines and ground.
- All lower levels including the selected test level must be satisfied. For testing the secondary protection, the output voltage of the generator must be increased up to the worst case voltage break down of the primary protection.

Test Results

The results of the test are reported as follows:

1. Normal performance within the specification limits.
2. Temporary degradation or loss of function or performance which is self-recoverable.
3. Temporary degradation or loss of function or performance which requires operator intervention or system reset.
4. Degradation or loss of function which is not recoverable, due to damage of equipment (component) or software, or loss of data.