



### Introduction

Metal Oxide Varistors (MOVs) are commonly used to suppress transients in many applications such as: Transient Voltage Surge Suppressors (TVSS), Uninterruptible Power Supplies (UPS), AC Power Taps, AC Power Meters or other products. Lightning, inductive load switching, or capacitor bank switching, are often the sources of these over-voltage transients. Under normal operating conditions, the AC line voltage applied to an MOV is not expected to exceed the MOV's Maximum ACRMS Voltage Rating or Maximum Continuous Operating Voltage (MCOV). Occasionally, over-voltage transients may occur that exceeds these limits. These transients are clamped to a suitable voltage level by the MOV provided the transient energy does not exceed the MOV's maximum rating.

MOVs can also be subjected to continuous abnormal voltage conditions rather than short duration transients. If an MOV is subjected to a sustained abnormal over-voltage, limited current condition (as is required in UL1449), the MOV may go into thermal runaway resulting in overheating, smoke, and potentially fire. For end products to comply with UL1449, some level of protection must be afforded to the MOV to prevent this failure mode. That protection has traditionally been a thermal fuse or Thermal Cut-Off (TCO) device.

### UL1449 Abnormal Overvoltage, Limited Current Requirements

In AC line applications, the loss of a Neutral-Ground connection may occur in such a way that there exists a risk that a sustained over-voltage may be applied to an MOV that is rated for a much lower continuous voltage. In an unlimited current condition the MOV will first fail to a low impedance (few Ohms), but due to the high amount of energy available, it most often ruptures instantaneously. If, however, there are loads tied to the AC line that limit current flow, the MOV can overheat and potentially cause the TVSS device to overheat resulting in smoke, out-gassing and eventually fire.

For example, in a standard U.S. 120V AC Line application, two 120V AC power lines (180° out of phase) are commonly fed from a center-tapped 240V transformer. See Figure 1. Let's assume a 150V rated MOV is present

in the top 120V circuit, and some load exists on the bottom 120V circuit. Both the MOV and load share the center tap which is the Neutral-Ground Connection. If a break occurs on the center tap (X—X), then the load in the bottom phase acts as a current limiter and the line fuse may not clear. In this scenario, the 150V rated MOV is subjected to 240V at a limited current potentially resulting in thermal run away for the MOV.

This potential condition is specifically identified and addressed in the UL1449 TVSS Standard. See Table 1. In many cases, it requires that end-product manufacturers include a thermal protection element for an MOV.

Table 1. defines the test voltage that should be applied to various TVSS devices depending on the designer's desired device1 rating. Each test voltage is applied across each conductor pair with a short circuit current of 5A, 2.5A,

Device Rating	Phase	Test Voltage <sup>(a)</sup>	Voltage Rating of Conductor Pair
110-120V	Single	240	All
110-120V/220-240V	Split	240	110-120V
120/208V	3-wye	208	120V
220-240	Single	415	All
220-240V/380-415V	3-wye	415	220-240V
240V	High Leg Delta	240	120V
254-277V	Single	480	All
254-277V/440-480V	3-wye	480	254-277V
480V	High Leg Delta	480	254-277V
347V	Single	600	All
347/600V	3-wye	600	347V

**Table 1.** Test voltage Selection Table

(a) For device ratings not specified in this table, the test voltage shall be the maximum phase voltage (if available) or twice the conductor pair voltage ratings up to 600V max.

0.5A and 0.125A respectively across each of four TVSS devices. Since this test is destructive, four devices are needed to test for each of the four short circuit currents. The four devices must be energized for 7 hours, or until current or temperatures within the TVSS device attain equilibrium, or until the TVSS becomes disconnected from the AC Line.

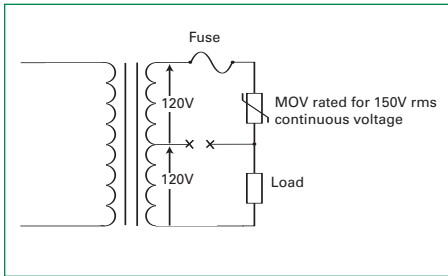
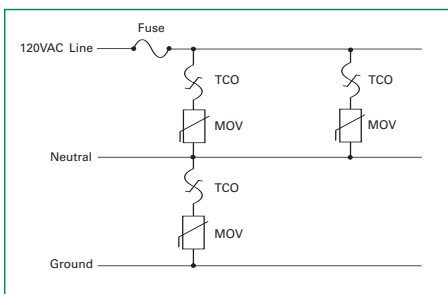

**Figure 1.** Possible Fault Condition for a limited current abnormal overvoltage event

For example shown in Figure 1, in a standard 120V AC Line application, the requirement is for a 240VACRMS test voltage to be applied across all conductor pairs. There are three pairs; Line-Neutral (L-N), Line-Ground (L-G), and Neutral-Ground (N-G). Again, this test voltage is chosen because in the U.S., 120V AC power is commonly fed from a center-tapped 240V transformer. Thermally unprotected MOVs for this application are typically rated from 130Vacrms to 150Vacrms and will heat up, out-gas and may catch fire in such circumstances.

### Thermally Protecting MOVs

A simple block diagram of a typical line voltage transient protection scheme used to meet the sustained abnormal over-voltage, limited current test requirements of UL1449 is shown in



**Figure 2.** Typical offline protection scheme

Figure 2. An MOV or several MOVs in parallel are each placed across each of the three conductive pairs; L-N, L-G, and N-G. This offers the utmost protection for any possible line transient. A standard fuse is placed in series with the line to protect the system from an over-current condition that exceeds a predetermined level. Typically, the current rating of this fuse is higher than the limited current flowing through the circuit during UL1449 testing. This requires the addition of a TCO that is placed in series with each MOV or Parallel combination of MOVs to protect it from a thermal event. Often, the MOVs used are of the radial leaded 14mm or 20mm disk diameter variety.

TCOs are available in a variety of different opening temperatures. The position and orientation of the TCO is important if it is to be effective in thermally protecting an MOV. When subjected to a sustained over-voltage, MOVs will short at a random point on the disk and will rapidly begin to self-heat if a limited current is maintained. TCOs are activated by a combination of conducted, converted and radiated heat from the MOV, although the majority of the heat is transferred via conduction. The position of the TCO in relation to the heat source at this shorting point has a considerable effect on the speed of operation of the TCO. The most effective heat coupling has been observed to be via conduction through the varistor terminal lead to the insulated terminal of a metal jacket TCO. Thermal convection and radiation processes are effective when the heat source is immediately beside or below the TCO. Although conduction is the most effective means of heat transfer, the MOV and TCO are not in full contact in most cases. The position of the terminal leads of the TCO makes it difficult for the TCO to be located closely enough to the MOV for effective heat transfer. The result is less than efficient conduction from

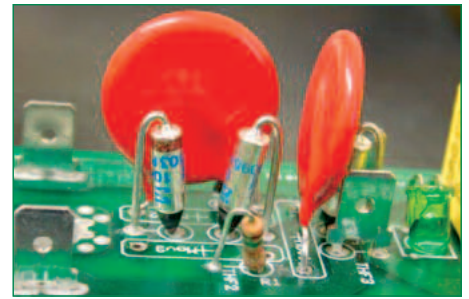

**Figure 3.** Typical Arrangement of TCOs with MOVs  
\*\* one of the MOVs has been removed for clarity

case to case. An example of a typical arrangement of MOVs and TCOs is shown in Figure 3. Note the TCO does not touch the case of the MOV.

The response time of this arrangement can be disproportionately increased if the TCO is not placed in close enough proximity to the MOV and/or the punch-through point on the MOV occurs remotely from the TCO's insulated terminal. In such cases, considerable charring of the MOV can occur and fire is a real possibility. Shrink-wrap or other bonding materials can aid coupling, but in adverse circumstances they are a source of combustible material and may actually make things worse.

While this scheme is generally effective in removing the MOV from the circuit during abnormal over-voltage testing such that the MOV does not reach critical temperatures, the downside to this method is that TCOs can be difficult to handle during the assembly process. Because of the low opening temperatures, TCOs must be soldered carefully. When hand soldering, the iron cannot remain in contact with the lead of the TCO for prolonged periods. Another option is to use clips or pliers as a heat-sink. TCOs with useful opening temperatures for the MOVs typically cannot be wave soldered, as the device will clear in the solder bath. In general, the use of TCOs in these types of applications becomes largely a hand assembly process.

A new technology has been developed that will aid the designer in meeting

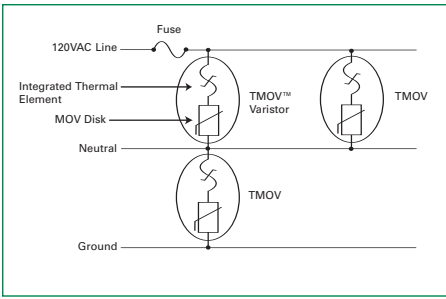

Figure 4. TMOV varistor offline protection scheme

UL1449 requirements including the sustained abnormal over-voltage limited current testing, while eliminating most of the problems associated with other methods. This technology is a fully integrated, thermally self-protected MOV - TMOV Varistor Series. This new device uses a patent pending thermal element internal to the MOV so that it is in direct contact with the metal oxide disk, allowing for optimum heat transfer. Because of the proximity of the thermal element to the MOV body, a higher opening temperature element can be used. This allows the thermally self-protected MOV to be wave soldered simplifying the assembly process. The construction method also allows the new device to perform to standard MOV ratings with regards to peak current, peak energy, voltage clamp levels, etc. while providing the safety of a thermally protected device. Figure 4. illustrates the integrated function.

### Comparing Methods of Thermally Protecting MOVs

The internally thermally protected TMOV varistor overcomes most of the disadvantages of the MOV/TCO combination method. Placing the thermal element inside the epoxy coating and close to the center of the disk provides several benefits. 1) It optimizes heat transfer between the MOV disk and the thermal element by placing the thermal element as close to the point of failure as possible. This greatly improves clearing (opening) times. 2) Allows for the thermal element to have a higher opening temperature than most TCOs used while being protected from external

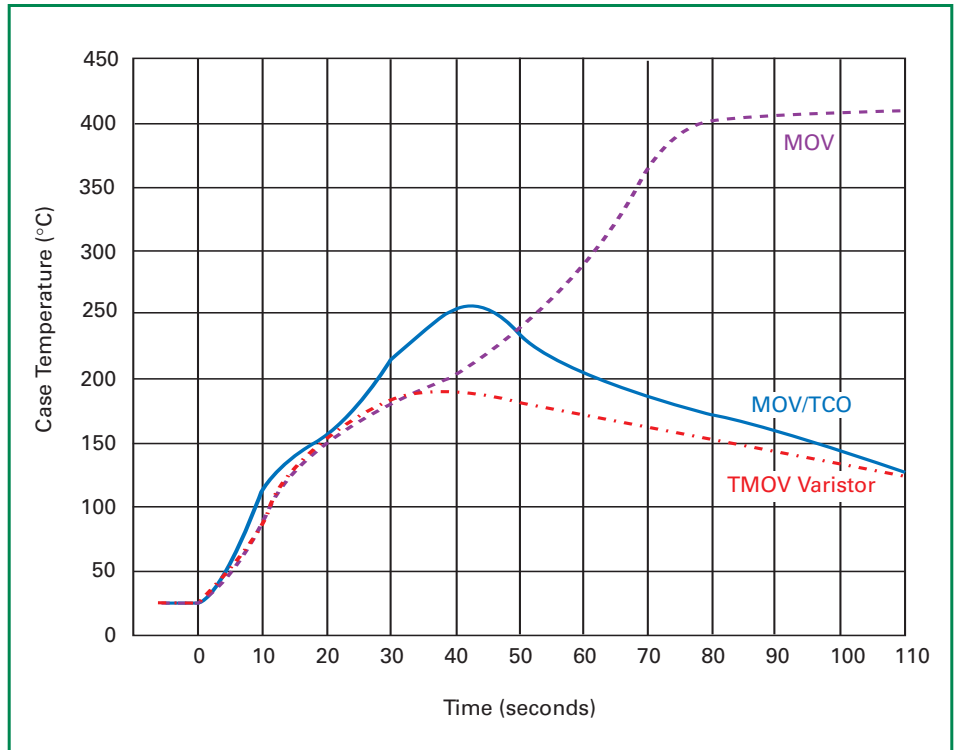

Figure 5. Typical surface temperature vs. time for several protection schemes

TCO Tf (°C)	Clearing Time (s)	
	Mean	Range
73	30	11-52
94	34	20-46
121	36	16-56

Table 2a. MOV/TCO observed clearing times for 5A limited current test

Tf (°C)	Clearing Time (s)	
	Mean	Range
TMOV varistor	13	2-25

Table 2b. TMOV varistor observed clearing times for 5A limited current test

heat sources. This allows the device to be wave soldered. See Section 6.

In order to compare the clearing times of both methods, several standard MOVs (Littelfuse 20mm, 130Vacrms, UltraMOV varistors) in combination with TCOs of various opening temperatures, Tf, were tested and compared with several thermally self protected MOVs (Littelfuse 20mm, 130Vacrms, TMOV™ varistor – TMOV20R130). Both methods were subjected to a sustained abnormal over-voltage of 240V at 5A. As

can be seen in Table 2a and as expected, the TCOs with higher Tf take longer to clear. The 73°C TCO proved difficult to hand solder without clearing the device despite the use of an appropriate heat-sink. Table 2b shows the clearing times for the internally protected MOV. Clearly, the times are shorter than for any of the MOV/TCO combinations tested.

Figure 5. shows the effects of applying a UL1449 abnormal over-voltage test (240VRMS, 5A) on three devices or combination of devices - 1) MOV alone (20mm, 130Vacrms – V20E130) 2) MOV/TCO combination (20mm, 130Vacrms MOV – V20E130 and TCO with Tf = 94°C), and 3) TMOV varistor (20mm, 130Vacrms – TMOV20R130).

Epoxy surface temperature vs. time was captured for each method. As can be seen, the case temperature of a standard MOV rated for 130VRMS will continue to rise (to the point of combustion) if no thermal protection is used. The MOV/TCO combo performs better reaching temperatures of 220°C before the TCO clears. The internally



Figure 6a. Standard MOV



Figure 6b. MOV/TCO combination



Figure 6c. TMOV varistor

protected MOV has a faster response time, clearing at temperatures of around 150°C in less than 20 seconds. Note that the temperature continues to rise once the thermal fuses have cleared. Heat generated within the zinc oxide disk is at a higher temperature than the outer epoxy coating. Heat continues to flow outward to the epoxy for some time before finally cooling down.

Figures 6a – 6c illustrate the effects of the temperature rise on each MOV. As can be seen, the new technology eliminates much of the charring when compared with a standard MOV or MOV/TCO combination.

### Wave Soldering the TMOV Varistor

Figure 7 shows a suitable wave solder profile that can be used for the TMOV varistor. The profile temperatures are very typical to those found in general

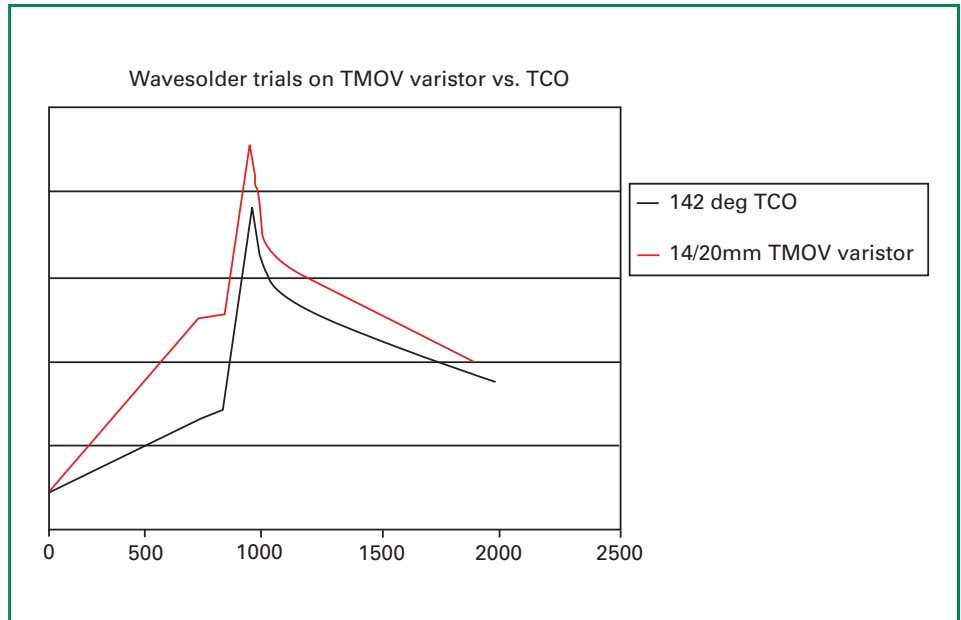

Figure 7. Wave solder profile of TMOV varistor vs. TCO (Tf=142°C)

wave solder methods. In contrast, the solder profile shown for the TCO shows temperatures much lower than those found in a typical solder bath. In fact, the profile shown for the TCO actually depicts a profile at which the TCO fails (opens) generally indicating that a TCO (even one with a high Tf (142°C) cannot be wave soldered.

Generally, there will be a cost benefit associated with eliminating the TCO which must be hand soldered carefully to avoid opening the element.

### Integrity of an Open Thermal Element

Once the thermal element of a TMOV varistor opens, it is important that the element stays open and that a reconnection does not occur. Remember, in order for the thermal element to have cleared (opened), the varistor disk itself must have heated up due to thermal run-away and the thermal runaway began with a failed (shorted) varistor. It is, therefore, undesirable to have a failed varistor placed back into the circuit, electrically speaking.

In order to ascertain the integrity of an open thermal element within a TMOV varistor, devices were first subjected to an abnormal over-voltage limited current

event causing the thermal element to clear. These devices were then subjected to two tests. First, the devices were subjected to 6kV, 3kA 8x20µsec pulses. The TMOV varistors were then subjected to bias voltage and monitored for leakage currents indicating a full or partial reconnection. None were noted. Next, 1000Vrms was applied for several hours, again with no connection as verified by the leakage test.

### Indication of an Open Thermal Element: iTMOV Varistor

The benefits of the TMOV varistor have been thoroughly discussed, but one question remains:

*How do I know when the thermal element has cleared?*

By design, MOVs exhibit a very high impedance when subjected to voltages below its MCOV (Maximum Continuous Operating Voltage). So, once installed into an end product, how do you know if the TMOV varistor is still operational? Enter the iTMOV varistor.

The iTMOV varistor adds an additional third indicator lead that provides access to the connection between the thermal element and the MOV electrode. Having access to this point of the circuit makes

**continued on reverse**

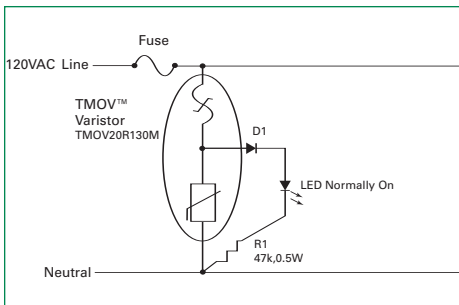

**Figure 8.** Indicator circuit using the iTMOV varistor (LED normally on)

indication of the thermal element a simple procedure. Figure 8 shows a simple application circuit with indication.

In Figure 8, an iTMOV varistor is used to protect the L-N connection of a typical U.S. 120Vac line. An AC rated LED is placed across the iTMOV varistor's indicator lead and the Neutral line. A series resistor, R1, is added to limit current through the LED. A 47k $\Omega$ , 0.5W resistor is shown, but the designer should review the LED's ratings to choose the correct value.

A series diode, D1, may be needed if the reverse voltage rating of the LED is insufficient to handle negative voltages from the AC line. Additionally, a Littelfuse 3AG, 10A (313010) fuse is shown to protect against excessive over-current into the load, but the designer should choose a value specific to his/her design.

Under normal conditions, the LED is forward biased from the line voltage through the thermal element to Neutral. If the thermal element opens current will be interrupted and the LED will go off. The LED will also go off if the Line Fuse opens indicating a loss of power.

When paralleling TMOV varistors, the iTMOV varistor can be used for several or all parallel devices. That is, one may wish to indicate when a certain percentage or TMOV varistors fail. Generally, once some of the MOVs in parallel begin to fail, all begin to fail.

## Conclusion

The UL1449 standard includes a requirement that was created to protect the end product and users from a loss of neutral situation where an abnormal over-voltage/limited current condition could be applied to Metal Oxide Varistors. This event would cause an MOV to have a sustained voltage applied in excess of its maximum working voltage, which in turn would cause the MOV to enter a thermal runaway condition.

Several methods exist to prevent the MOV from reaching combustible temperatures - the most common of which is to use TCOs. While TCOs perform adequately in limiting MOVs from reaching very high temperatures, there are limitations. Out-gassing and some charring are evident when the test is applied. Additionally, the assembly process is difficult to automate, as wave soldering is typically not an option.

Overall, the new integrated TMOV varistor thermal fuse technology reduces part count, saves space and is UL1449 recognized. It performs better than other methods of protection when subjected to a limited current over-voltage condition, by clearing more quickly at a lower temperature to reduce the potential for out-gassing or charring. It has all the performance capability of a standard MOV, including peak pulse current capability, energy rating and clamping voltage. The new device can also be wave soldered which saves on assembly costs and simplifies the assembly process by eliminating most of the hand assembly required with other methods.

## Note:

All data was taken with a limited sample size. Results may vary due to normal variations in electrical and mechanical parameters. Designers are encouraged to evaluate their end design with a large enough sample size to ensure consistent results. In some instances TMOV varistors may exhibit substantial heating and venting prior to opening. Module design should be such as to contain this possibility. Application testing is strongly recommended.

## References:

1. Transient Voltage Surge Suppressors - UL1449, June 25, 1998
  2. Littelfuse Datasheet, Thermally Protected Metal Oxide Varistor (TMOV Varistor), March 2001
  3. Littelfuse Datasheet, High Surge Current Radial Lead Metal Oxide Varistor (UltraMOV Varistor Series), March 2001
  4. Paul Traynham and Pat Bellew, Using Thermally Protected MOVs in TVSS or Power Supply Applications, Power Systems World, Intertec Exhibition Proceedings, September 2001
1. In Table 1, "device" is defined as the end TVSS product - example: UPS, TVSS Strip etc.



**World Headquarters**

Littelfuse, Inc.  
800 E. Northwest Highway  
Des Plaines, IL 60016, USA

**[www.littelfuse.com](http://www.littelfuse.com)**

FORM NO. EC-635

© 2004 Littelfuse, Inc. Printed in U.S.A. July 2004  
Specifications, descriptions and illustrative material in  
this literature are as accurate as known at time of publication,  
but are subject to change without notice.