

RoHS **Pb** **AC and CG3 Series Suppressors**

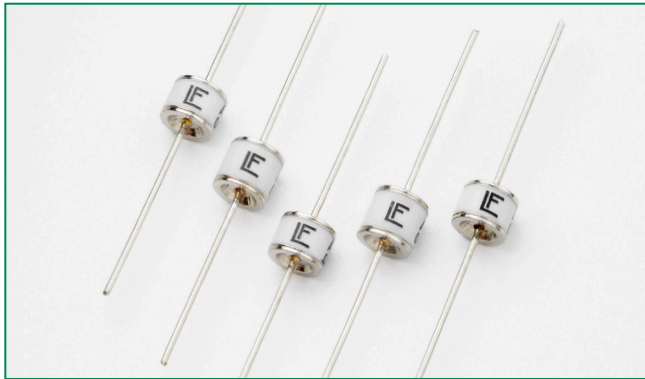

Description

Littelfuse AC series two-electrode line protectors provide a high degree of surge protection in AC line applications. The two models, AC120 and AC240 are designed for use with 120VAC and 240VAC lines respectively. They are able to extinguish AC follow-on currents of at least 200A.

Littelfuse CG3 two electrode high voltage (1.0 - 7.5 KV) devices are designed for surge protection and high isolation applications, and for applications for which bias voltages or signal levels of several hundred volts are normally present.

Agency Approvals

| AGENCY | AGENCY FILE NUMBER |
|--------|--------------------|
| | E320116* |

*NOTE: CG3 7.5 product UL approval is currently pending

Features

- Rugged ceramic-metal construction
- Available in tape-and-reel packaging
- Low capacitance (<1.5 pF)
- Available with or without leads

2 Electrode GDT Graphical Symbol

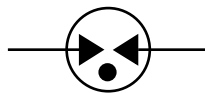

Applications

AC Series:

- Long branch circuits (AC wall outlet)
- Short branch circuits (at breaker box, computer, etc)
- Power supplies
- Test equipment
- Submersible pumps
- Medical electronics

CG3 Series:

- CRT terminals
- CATV equipment
- Antennas
- Power supplies
- Medical electronics

Electrical Characteristics

| Part Number | Device Dimension Type | Device Specifications (at 25°C) | | | | | | | Life Ratings | | | | | |
|------------------------|-----------------------|---------------------------------|------|------|--|--|-----------------------|---------------------|--|------------------------------------|---|--|--|--|
| | | DC Breakdown in Volts (@100V/s) | | | Impulse Break-down in Volts (@100V/μs) | Impulse Break-down In Volts (@1 Kv/μsec) | Insulation Resistance | Capacitance (@1MHz) | Arc Voltage (on state Voltage) @1Amp Min | Max Follow On Current ³ | Nominal AC Discharge Current (10x1sec @50-60Hz) | AC Discharge Current (1 x 50Hz 9 cycles) | Nominal Impulse Discharge Current ⁴ (@8/20μs) | Max Surge Current ⁵ (@8/20μs) |
| | | MIN | TYP | MAX | MAX | | MIN | MAX | TYP | | | | | |
| AC120 ¹ | A | 230 | 285 | 340 | 500 | 550 | 10 GΩ (at 100V) | <1.5 pf | ~ 25 V | 200 Amps | 5 A | 65 A | 10 shots 5kA | 1 shot 10kA |
| AC240 ¹ | A | 480 | 600 | 720 | 1100 | 1200 | | | | | | | | |
| CG3 1.0 ¹ | A | 800 | 1000 | 1200 | 1400 | 1500 | 10 GΩ (at 100V) | <1.5 pf | ~ 25 V | 200 Amps | N/A | N/A | 10 shots 5kA | 1 shot 10kA |
| CG3 1.1 ¹ | A | 880 | 1100 | 1320 | 1600 | 1700 | | | | | | | | |
| CG3 1.2 ¹ | A | 960 | 1200 | 1440 | 1700 | 1800 | | | | | | | | |
| CG3 1.3 ¹ | A | 1040 | 1300 | 1560 | 1800 | 1900 | | | | | | | | |
| CG3 1.5 ¹ | A | 1200 | 1500 | 1800 | 1800 | 2000 | | | | | | | | |
| CG3 2.0 ¹ | A | 1600 | 2000 | 2400 | 2500 | 2750 | | | | | | | | |
| CG3 2.5 ¹ | A | 2000 | 2500 | 3000 | 3200 | 3500 | | | | | | | | |
| CG3 2.7 ¹ | A | 2160 | 2700 | 3240 | 3600 | 4000 | | | | | | | | |
| CG3 3.0 ¹ | A | 2400 | 3000 | 3600 | 4000 | 4200 | | | | | | | | |
| CG3 3.3 ¹ | A | 2640 | 3300 | 3960 | 4600 | 4700 | | | | | | | | |
| CG3 4.0 ² | B | 3200 | 4000 | 4800 | 5800 | 6000 | | | | | | | | |
| CG3 4.5 ² | B | 3600 | 4500 | 5400 | 6150 | 6500 | | | | | | | | |
| CG3 5.0 ² | B | 4000 | 5000 | 6000 | 7500 | 8000 | | | | | | | | |
| CG3 6.2 ² | B | 4960 | 6200 | 7440 | 8100 | 9500 | | | | | | | | |
| CG3 6.5 ² | B | 5200 | 6500 | 7800 | 9500 | 10000 | | | | | | | | |
| CG3 7.5 ^{2,6} | B | 6000 | 7500 | 9000 | 10000 | 10600 | | | | | | | | |

- NOTES:
1. Refer to Production Dimensions section, outline A devices
 2. Refer to Production Dimensions section, outline B devices
 3. Tested to UL1449 Third Edition – 120V r.ms. for AC120, 230V r.ms. all others. Conducted with suitable MOV connected in series.
 4. 10 x [5(+)] and 5(-)] applications 5kA @ 8/20μs
 5. 1 x [1(+)] and 1(-)] application 10kA @ 8/20μs
 6. CG3 7.5 product UL approval is currently pending

Product Characteristics

| | |
|--|--|
| Materials | Core Outline A & B items: Device: Tin Plated 17.5±12.5 Microns Axial Outline A items: Device: Nickel Plated 2–5 Microns Wire: Tin Plated 17.5±12.5 Microns Axial Outline B items: Device & Wire: Tin Plated 17.5±12.5 Microns |
| Product Marking | LF Logo, Voltage and date code; Black ink positive print |
| Glow to arc transition current | < 0.5Amps |
| Glow Voltage | ~ 140 Volts |
| Storage and Operational Temperature | -40 to +90 |

Soldering Parameters - Reflow Soldering (Surface Mount Devices)

| | | |
|--|------------------------------------|-------------------------|
| Reflow Condition | | Pb – Free assembly |
| Pre Heat | - Temperature Min ($T_{s(min)}$) | 150°C |
| | - Temperature Max ($T_{s(max)}$) | 200°C |
| | - Time (Min to Max) (t_s) | 60 – 180 secs |
| Average ramp up rate (Liquidus Temp (T_L) to peak) | | 3°C/second max |
| $T_{s(max)}$ to T_L - Ramp-up Rate | | 5°C/second max |
| Reflow | - Temperature (T_L) (Liquidus) | 217°C |
| | - Temperature (t_L) | 60 – 150 seconds |
| Peak Temperature (T_p) | | 260 ^{+0/-5} °C |
| Time within 5°C of actual peak Temperature (t_p) | | 10 – 30 seconds |
| Ramp-down Rate | | 6°C/second max |
| Time 25°C to peak Temperature (T_p) | | 8 minutes Max. |
| Do not exceed | | 260°C |

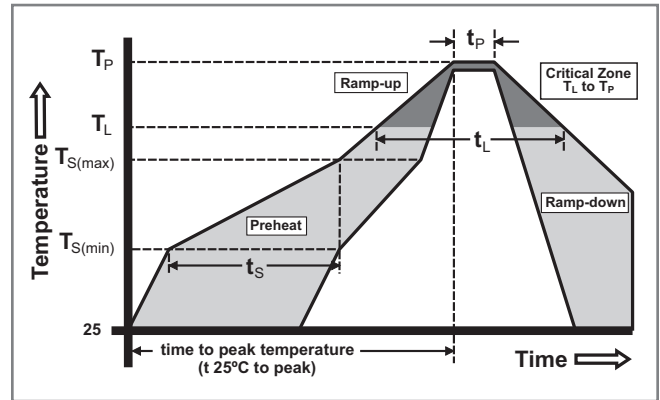

Soldering Parameters - Wave Soldering (Thru-Hole Devices)

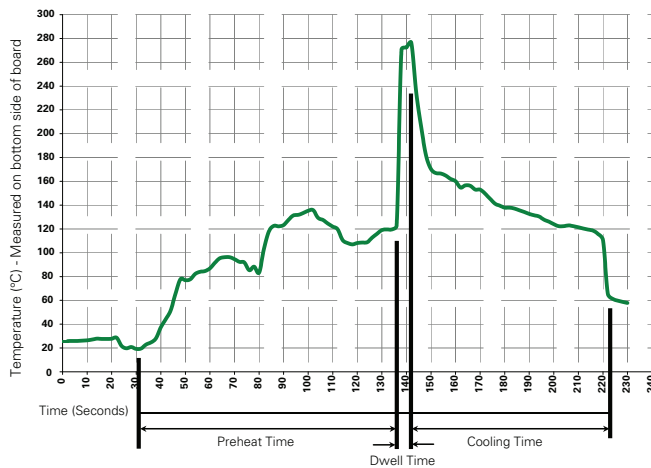

Recommended Process Parameters:

| Wave Parameter | Lead-Free Recommendation |
|---|--------------------------|
| Preheat: (Depends on Flux Activation Temperature) (Typical Industry Recommendation) | |
| Temperature Minimum: | 100° C |
| Temperature Maximum: | 150° C |
| Preheat Time: | 60-180 seconds |
| Solder Pot Temperature: | 280° C Maximum |
| Solder Dwell Time: | 2-5 seconds |

Soldering Parameters - Hand Soldering

Solder Iron Temperature: 350° C +/- 5°C
 Heating Time: 5 seconds max.

Device Dimensions

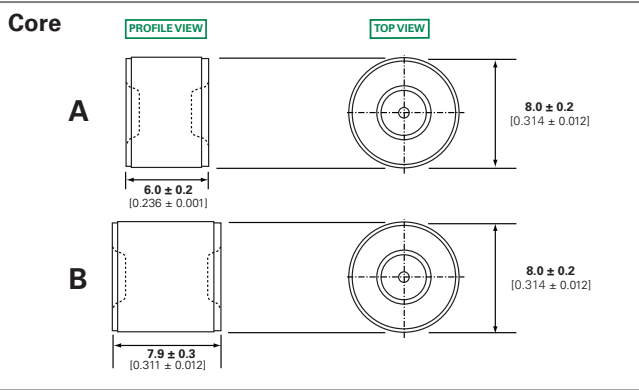
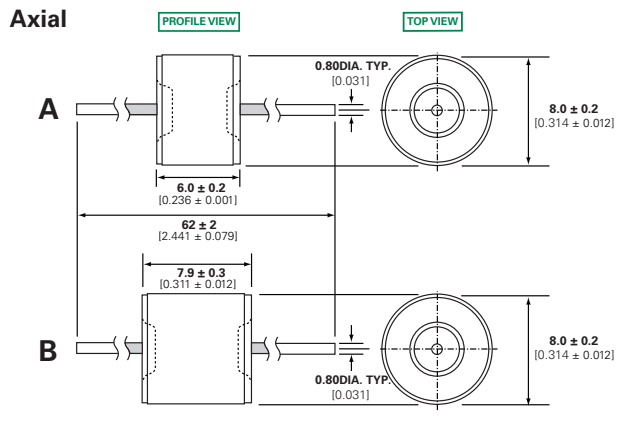

Part Numbering System and Ordering Information

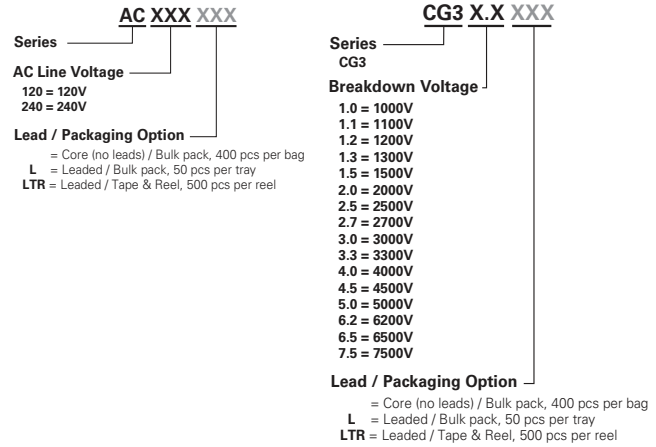

Packaging Dimensions

For 'LTR' Option Code Axial Lead Items

