







# PulseGuard® Suppressors

	PAGE
  PGB1 Series, 0603, Lead-Free, Single Line Surface Mount ESD Suppressor . . . . .	202-203
  PCB1 Series, SOT23, Lead-Free, Two Line Surface Mount ESD Suppressor . . . . .	204-205
  PGB1 Series, 0805 Lead-Free Four Line Surface Mount ESD Suppressor . . . . .	206-207
PGB Series, 0603, Single Line Surface Mount ESD Suppressor . . . . .	208-209
PCB Series, SOT23, Two Line Surface Mount ESD Suppressor . . . . .	210-211
PGB Series, 0805 Four Line Surface Mount ESD Suppressor . . . . .	212-213
<b>PGD Series Connector Array ESD Suppressors . . . . .</b>	<b>214</b>

# PulseGuard® Suppressors

## Surface Mount Polymeric ESD Suppressors

### NEW PGB1 Series Lead-Free 0603 ESD Suppressor

#### Product Overview

PulseGuard ESD Suppressors help protect sensitive electronic equipment against electrostatic discharge (ESD). They supplement the on-chip protection of integrated circuitry and are best suited for low-voltage, high-speed applications where low capacitance is important. Data ports utilizing such high-speed protocols as USB 2.0, IEEE1394, HDMI and DVI can benefit from this new technology.

PulseGuard suppressors use polymer composite materials to suppress fast-rising ESD transients (as specified in IEC 61000-4-2 and MIL-STD-883C), while adding virtually no capacitance to the circuit.

#### Features

- Lead-Free and RoHS compliant
- Ultra-low capacitance
- Low leakage current
- Fast response time
- Single line of protection
- Bi-directional
- Withstands multiple ESD strikes
- Standard EIA SOCM-1608 package
- Compatible with pick-and-place processes
- Available in 1,000 and 5,000 piece reels (EIA-RS481)

#### Typical Applications

- HDTV Hardware
- Laptop/Desktop Computers
- Network Hardware
- Computer Peripherals
- Digital Cameras
- External Storage
- Set-Top Boxes

#### Ordering Information

CATALOG NUMBER	PIECES PER REEL
PGB1010603MR	1,000
PGB1010603NR	5,000

#### Design Consideration

Because of the fast rise-time of the ESD transient, placement of PulseGuard suppressors is a key design consideration. To achieve optimal ESD suppression, the devices should be placed on the circuit board as close to the source of the ESD transient as possible. Install PulseGuard suppressors directly behind the connector so that they are the first board-level circuit component encountered by the ESD transient. They are connected from signal/data line to ground.

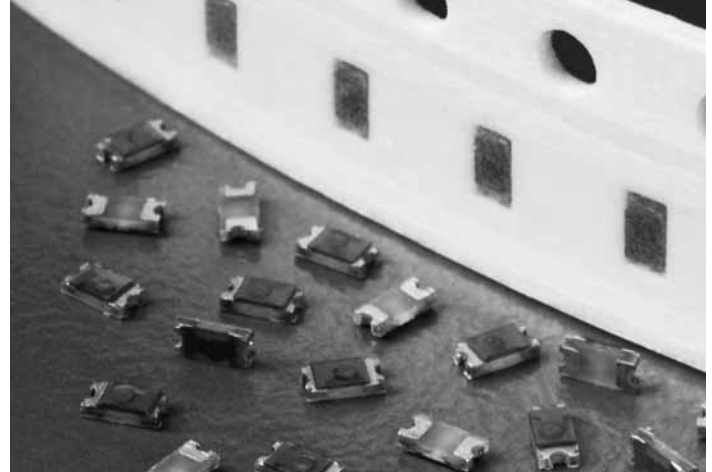

#### Reference Dimensions:

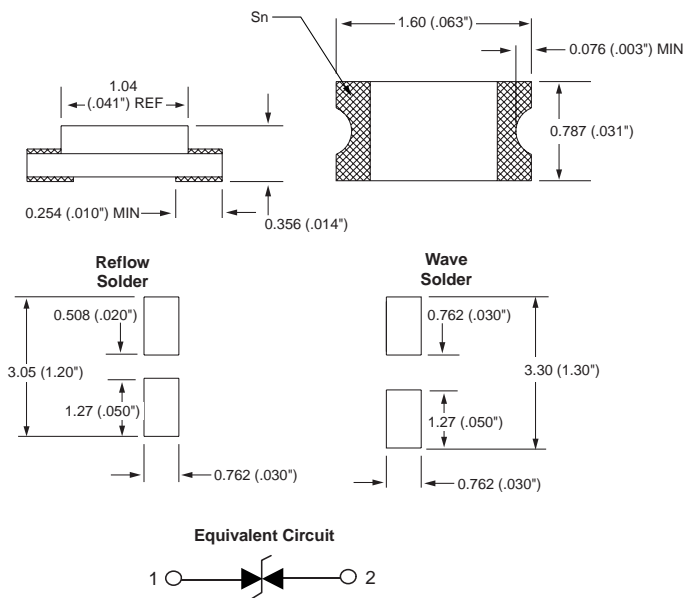

# PulseGuard® Suppressors

Surface Mount Polymeric ESD Suppressors

## RoHS PGB1 Series Lead-Free 0603 ESD Suppressor

### Electrical Characteristics

#### ESD Capability

IEC 61000-4-2 Direct Discharge .....	8kV
IEC 61000-4-2 Air Discharge .....	15kV
Trigger Voltage <sup>1</sup> .....	500V, typical
Clamping Voltage <sup>1</sup> .....	150V, typical
Rated Voltage .....	24VDC, max
Capacitance <sup>2</sup> .....	0.055 pF
Response Time <sup>1</sup> .....	< 1 ns
Leakage Current <sup>3</sup> .....	< 1nA
ESD Pulse Withstand <sup>4</sup> .....	1,000 pulses, minimum

#### Notes:

1. Trigger and clamping voltage measured per IEC 61000-4-2, 8kV direct discharge method.
2. Capacitance measured at 1MHz.
3. Leakage current measured at 6VDC.
4. Pulse Withstand- some shifting in characteristics may occur when tested over multiple pulses at a very rapid rate.

### Environmental Specifications

**Operating Temperature:** -65°C to +125°C.

**Moisture Resistance, steady state:** MIL-STD-833, method 1004.7, 85% RH, 85°C, 1000hrs.

**Thermal Shock:** MIL-STD-202, Method 107G, -65°C to 125°C, 30 min cycle, 10 cycles.

**Vibration:** MIL-STD-202F, Method 201A, (10 to 55 to 10Hz, 1 min. cycle, 2grs each in X-Y-Z)

**Chemical Resistance:** ASTM D-543, 4hrs @ 40°C, 3 solutions (H<sub>2</sub>O, detergent solution, defluxer)

**Solder leach resistance and terminal adhesion:** Per EIA-576 test

### Physical Specifications

#### Materials:

Body: Glass Epoxy

Terminations: 100% Copper/Nickel/Tin

#### Solderability:

MIL-STD-202, Method 208 (95% coverage)

#### Soldering Parameters:

Wave solder - 260°C, 10 seconds maximum

Reflow solder - 260°C, 30 seconds maximum

#### Operating Temperature Range:

-65°C to +125°C

### Packaging Specifications

8mm Tape and Reel per EIA-RS481-1 (IEC 286, part3); 1,000 pieces per reel, add packaging suffix, MR; 5,000 per reel, add packaging suffix NR.

### Capacitance vs. Frequency

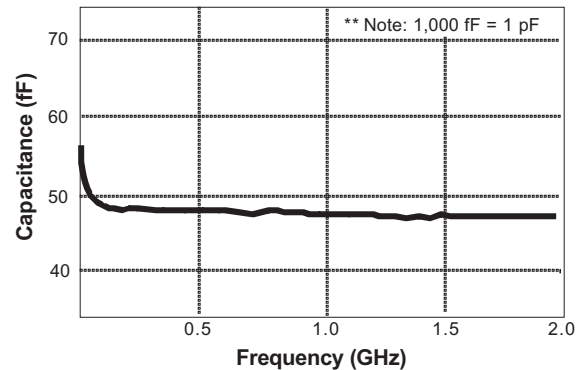

### Carrier Tape Specifications

Parts are delivered on 7" (178mm) reel, paper carrier tape

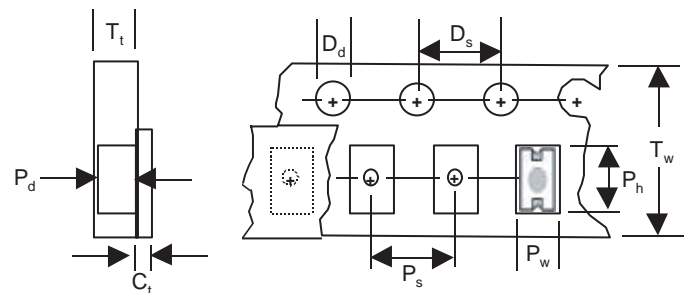

DESCRIPTION	MEASUREMENT (MM)
C <sub>t</sub> - Cover tape thickness	0.06
D <sub>d</sub> - Drive hole diameter	1.50
D <sub>s</sub> - Drive hole spacing	4.00
P <sub>d</sub> - Pocket depth	0.58
P <sub>h</sub> - Pocket height	1.85
P <sub>s</sub> - Pocket spacing	4.00
P <sub>w</sub> - Pocket width	1.02
T <sub>t</sub> - Carrier tape thickness	0.65
T <sub>w</sub> - Carrier tape width	8.00

# PulseGuard® Suppressors

## Surface Mount Polymeric ESD Suppressors

### NEW RoHS Pb PGB1 Series Lead-Free SOT23 ESD Suppressor

#### Product Overview

PulseGuard ESD Suppressors help protect sensitive electronic equipment against electrostatic discharge (ESD). They supplement the on-chip protection of integrated circuitry and are best suited for low-voltage, high-speed applications where low capacitance is important. Data ports utilizing such high-speed protocols as USB 2.0, IEEE1394, HDMI, and DVI can benefit from this new technology. PulseGuard suppressors use polymer composite materials to suppress fast-rising ESD transients (as specified in IEC 61000-4-2 and MIL-STD-883E), while adding virtually no capacitance to the circuit.

#### Features

- Lead-Free
- Ultra-low capacitance
- Low leakage current
- Fast response time
- 2-lines of protection
- Bi-directional
- Withstands multiple ESD strikes
- Standard JEDEC SOT23 outline
- Compatible with pick-and-place processes
- Available in 3,000 piece reels

#### Typical Applications

- HDTV Hardware
- Laptop/Desktop Computers
- Network Hardware
- Computer Peripherals
- Digital Cameras
- External Storage
- Set-Top Boxes

#### Ordering Information

CATALOG NUMBER	PIECES PER REEL
PGB102ST23WR	3,000

#### Design Consideration

Because of the fast rise-time of the ESD transient, placement of PulseGuard suppressors is a key design consideration. To achieve optimal ESD suppression, the devices should be placed on the circuit board as close to the source of the ESD transient as possible. Install PulseGuard suppressors directly behind the connector so that they are the first board-level circuit component encountered by the ESD transient. They are connected from signal/data line to ground.



#### Reference Dimensions:

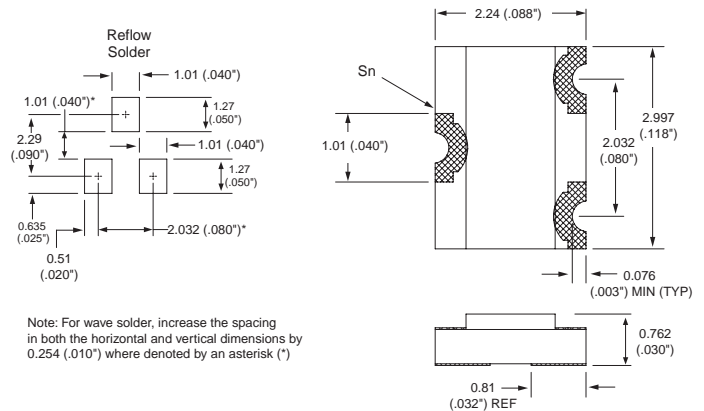

#### Equivalent Circuit

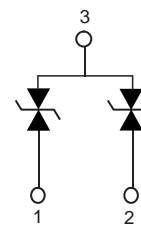

# PulseGuard® Suppressors

Surface Mount Polymeric ESD Suppressors

## NEW PGB1 Series Lead-Free SOT23 ESD Suppressor

### Electrical Characteristics

#### ESD Capability

IEC 61000-4-2 Direct Discharge .....	8kV
IEC 61000-4-2 Air Discharge .....	15kV
Trigger Voltage <sup>1</sup> .....	500V typical
Clamping Voltage <sup>1</sup> .....	150V typical
Rated Voltage .....	24VDC max
Capacitance <sup>2</sup> .....	0.055pF
Response Time <sup>1</sup> .....	<1ns
Leakage Current <sup>3</sup> .....	<1nA
ESD Pulse Withstand <sup>4</sup> .....	1,000 pulses minimum

#### Notes:

1. Trigger and clamping voltage measured per IEC 61000-4-2, 8kV direct discharge method.
2. Capacitance measured at 1MHz.
3. Leakage current measured at 6VDC.
4. Pulse Withstand- some shifting in characteristics may occur when tested over multiple pulses at a very rapid rate.

### Environmental Specifications

**Operating Temperature:** -65°C to +125°C.

**Moisture Resistance, steady state:** MIL-STD-833, method 1004.7, 85% RH, 85°C, 1000hrs.

**Thermal Shock:** MIL-STD-202, Method 107G, -65°C to 125°C, 30 min cycle, 10 cycles.

**Vibration:** MIL-STD-202F, Method 201A, (10 to 55 to 10Hz, 1 min. cycle, 2grs each in X-Y-Z)

**Chemical Resistance:** ASTM D-543, 4hrs @ 40°C, 3 solutions (H<sub>2</sub>O, detergent solution, defluxer)

**Solder leach resistance and terminal adhesion:** Per EIA-576 test

### Physical Specifications

#### Materials:

Body: Glass Epoxy

Terminations: 100% Copper/Nickel/Tin

**Solderability:** MIL-STD-202, Method 208 (95% coverage)

#### Soldering Parameters:

Wave Solder – 260°C, 10 seconds maximum.

Reflow Solder – 260°C, 30 seconds maximum.

### Packaging Specifications

8mm Tape and Reel per EIA-RS481-1 (IEC 286, part3); 3,000 pieces per reel, add packaging suffix, WR.

### Capacitance vs. Frequency

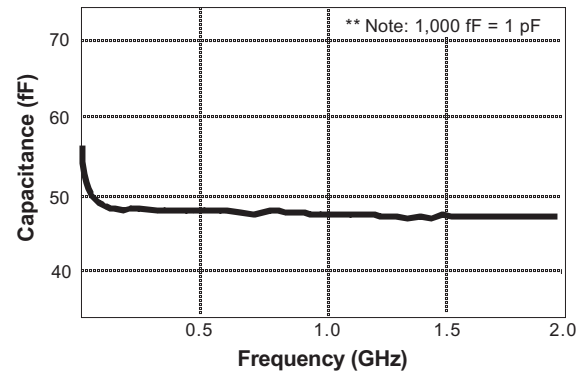

### Carrier Tape Specifications

Parts are delivered on 7" (178mm) reel, plastic carrier tape

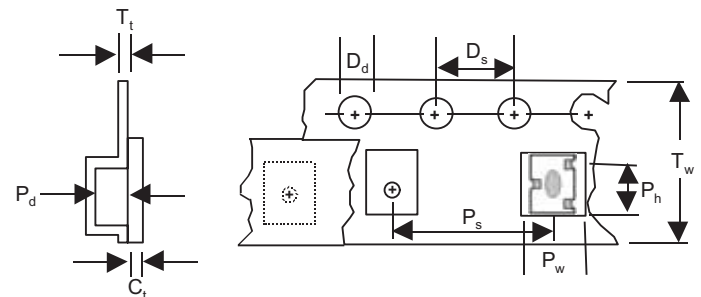

DESCRIPTION	MEASUREMENT (MM)
C <sub>t</sub> - Cover tape thickness	0.06
D <sub>d</sub> - Drive hole diameter	1.50
D <sub>s</sub> - Drive hole spacing	4.00
P <sub>d</sub> - Pocket depth	1.02
P <sub>h</sub> - Pocket height	3.23
P <sub>s</sub> - Pocket spacing	4.00
P <sub>w</sub> - Pocket width	2.46
T <sub>t</sub> - Carrier tape thickness	0.30
T <sub>w</sub> - Carrier tape width	8.00

4  
PULSEGUARD®  
SUPPRESSORS

# PulseGuard® Suppressors

## Surface Mount Polymeric ESD Suppressors

### **NEW** **PGB1 Series Lead-Free 0805 ESD Suppressor**

#### Product Overview

PulseGuard ESD Suppressors help protect sensitive electronic equipment against electrostatic discharge (ESD). They supplement the on-chip protection of integrated circuitry and are best suited for low-voltage, high-speed applications where low capacitance is important. Data ports utilizing such high-speed protocols as USB 2.0, IEEE1394, HDMI and DVI can benefit from this new technology. PulseGuard suppressors use polymer composite materials to suppress fast-rising ESD transients (as specified in IEC 61000-4-2 and MIL-STD-883E), while adding virtually no capacitance to the circuit.

#### Features

- Lead-Free
- Ultra-low capacitance
- Low leakage current
- Fast response time
- 4-lines of protection
- Bi-directional
- Withstands multiple ESD strikes
- Based on industry standard 2012 package
- Compatible with pick-and-place processes
- Available in 1,000 and 5,000 piece reels (EIA-RS481)

#### Typical Applications

- HDTV Hardware
- Laptop/Desktop Computers
- Network Hardware
- Computer Peripherals
- Digital Cameras
- External Storage
- Set-Top Boxes

#### Ordering Information

CATALOG NUMBER	PIECES PER REEL
PGB1040805MR	1,000
PGB1040805NR	5,000

#### Design Consideration

Because of the fast rise-time of the ESD transient, placement of PulseGuard suppressors is a key design consideration. To achieve optimal ESD suppression, the devices should be placed on the circuit board as close to the source of the ESD transient as possible. Install PulseGuard suppressors directly behind the connector so that they are the first board-level circuit component encountered by the ESD transient. They are connected from signal/data line to ground.

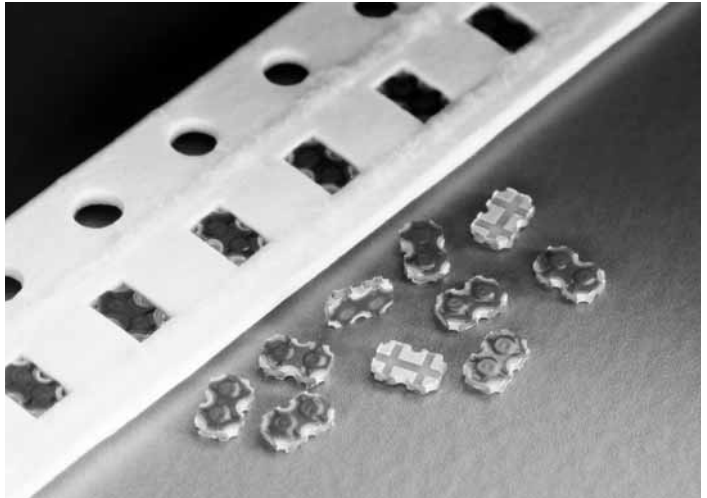

Reference Dimensions:

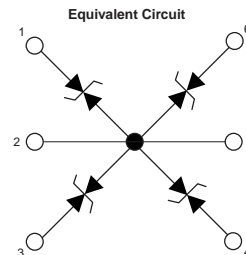
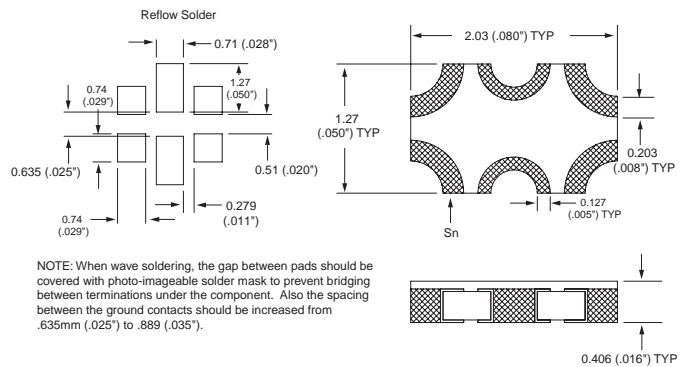

# PulseGuard® Suppressors

## Surface Mount Polymeric ESD Suppressors

### NEW PGB1 Series Lead-Free 0805 ESD Suppressor

#### Electrical Characteristics

ESD Capability	
IEC 61000-4-2 Direct Discharge .....	8kV
IEC 61000-4-2 Air Discharge .....	15kV
Trigger Voltage <sup>1</sup> .....	500 V, typical
Clamping Voltage <sup>1</sup> .....	150V, typical
Rated Voltage .....	24VDC, max
Capacitance <sup>2</sup> .....	0.055 pF
Response Time <sup>1</sup> .....	< 1ns
Leakage Current <sup>3</sup> .....	< 1nA
ESD Pulse Withstand <sup>4</sup> .....	1,000 pulses, minimum

Notes:

1. Trigger and clamping voltage measured per IEC 61000-4-2, 8kV direct discharge method.
2. Capacitance measured at 1MHz.
3. Leakage current measured at 6VDC.
4. Pulse Withstand- some shifting in characteristics may occur when tested over multiple pulses at a very rapid rate.

#### Environmental Specifications

- Operating Temperature:** -65°C to +125°C.  
**Moisture Resistance, steady state:** MIL-STD-833, method 1004.7, 85% RH, 85°C, 1000hrs.  
**Thermal Shock:** MIL-STD-202, Method 107G, -65°C to 125°C, 30 min cycle, 10 cycles.  
**Vibration:** MIL-STD-202F, Method 201A, (10 to 55 to 10Hz, 1 min. cycle, 2grs each in X-Y-Z)  
**Chemical Resistance:** ASTM D-543, 4hrs @ 40°C, 3 solutions (H2O, detergent solution, defluxer)  
**Solder leach resistance and terminal adhesion:** Per EIA-576 test

#### Physical Specifications

- Materials:**  
 Body: Glass Epoxy  
 Terminations: 100% Copper/Nickel/Tin  
**Solderability:** MIL-STD-202, Method 208 (95% coverage)  
**Soldering Parameters:**  
 Wave Solder – 260°C, 10 seconds maximum.  
 Reflow Solder – 260°C, 30 seconds maximum.

#### Packaging Specifications

8mm Tape and Reel per EIA-RS481-1 (IEC 286, part3); 1,000 pieces per reel, add packaging suffix, MR; 5,000 per reel, add packaging suffix NR.

Capacitance vs. Frequency

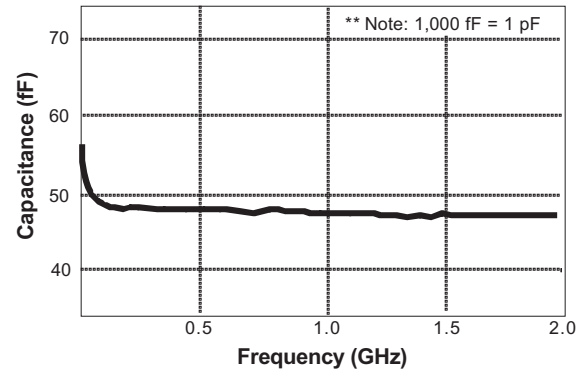

#### Carrier Tape Specifications

Parts are delivered on 7" (178mm) reel, paper carrier tape

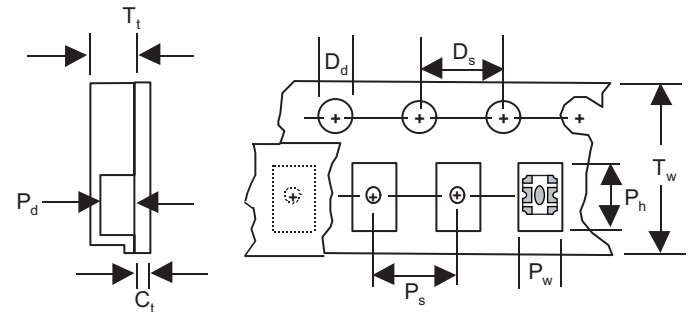

DESCRIPTION	MEASUREMENT (MM)
C <sub>t</sub> - Cover tape thickness	0.06
D <sub>d</sub> - Drive hole diameter	1.50
D <sub>s</sub> - Drive hole spacing	4.00
P <sub>d</sub> - Pocket depth	0.58
P <sub>h</sub> - Pocket height	2.21
P <sub>s</sub> - Pocket spacing	4.00
P <sub>w</sub> - Pocket width	1.45
T <sub>t</sub> - Carrier tape thickness	0.65
T <sub>w</sub> - Carrier tape width	8.00

4  
PULSEGUARD®  
SUPPRESSORS

# PulseGuard® Suppressors

## Surface Mount Polymeric ESD Suppressors

### PGB Series 0603 ESD Suppressor

#### Product Overview

PulseGuard ESD Suppressors help protect sensitive electronic equipment against electrostatic discharge (ESD). They supplement the on-chip protection of integrated circuitry and are best suited for low-voltage, high-speed applications where low capacitance is important. Data ports utilizing such high-speed protocols as USB 2.0, IEEE1394 and InfiniBand<sup>SM</sup> can benefit from this new technology.

PulseGuard suppressors use polymer composite materials to suppress fast-rising ESD transients (as specified in IEC 61000-4-2 and MIL-STD-883C).

#### Features

- Ultra-low capacitance
- Low leakage current
- Fast response time
- Single line of protection
- Bi-directional
- Withstands multiple ESD strikes
- Standard EIA SOCM-1608 package
- Compatible with pick-and-place processes
- Available in 1,000 and 5,000 piece reels (EIA-RS481)

#### Typical Applications

- Servers
- Laptop/Desktop Computers
- Network Hardware
- Computer Peripherals
- Digital Cameras
- External Storage

#### Ordering Information

CATALOG NUMBER	PIECES PER REEL
PGB0010603MR	1,000
PGB0010603NR	5,000

#### Design Consideration

Because of the fast rise-time of the ESD transient, placement of PulseGuard suppressors is a key design consideration. To achieve optimal ESD suppression, the devices should be placed on the circuit board as close to the source of the ESD transient as possible. Install PulseGuard suppressors directly behind the connector so that they are the first board-level circuit component encountered by the ESD transient. They are connected from signal/data line to ground.

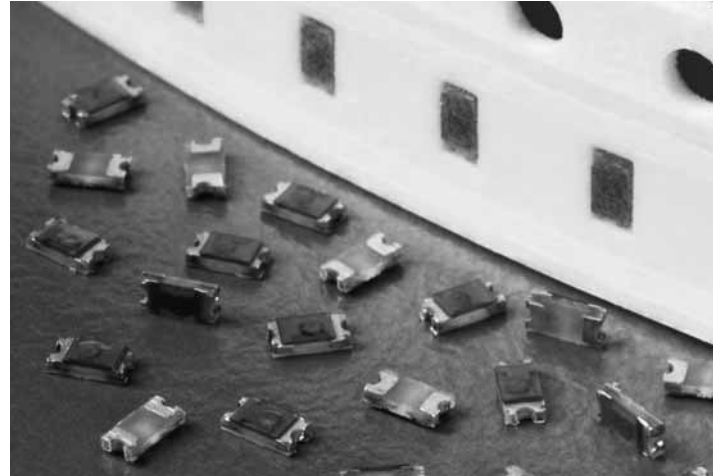

Reference Dimensions:

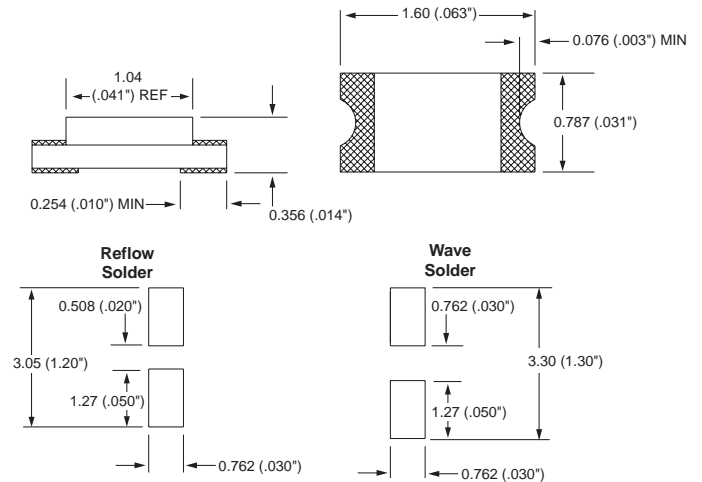

Equivalent Circuit



# PulseGuard® Suppressors

## Surface Mount Polymeric ESD Suppressors

### PGB Series 0603 ESD Suppressor

#### Electrical Characteristics

ESD Capability:

IEC 61000-4-2 Direct Discharge .....	8kV
IEC 61000-4-2 Air Discharge .....	15kV
Trigger Voltage <sup>1</sup> .....	1,000V, typical
Clamping Voltage <sup>1</sup> .....	150V, typical
Rated Voltage .....	24VDC, max
Capacitance <sup>2</sup> .....	0.055 pF
Response Time <sup>1</sup> .....	< 1 ns
Leakage Current <sup>3</sup> .....	< 1nA
ESD Pulse Withstand <sup>4</sup> .....	1,000 pulses, minimum

Notes:

1. Trigger and clamping voltage measured per IEC 61000-4-2, 8kV direct discharge method.
2. Capacitance measured at 1MHz.
3. Leakage current measured at 6VDC.
4. Pulse Withstand- some shifting in characteristics may occur when tested over multiple pulses at a very rapid rate.

#### Environmental Specifications

**Operating Temperature:** -65°C to +125°C.

**Moisture Resistance, steady state:** MIL-STD-833, method 1004.7, 85% RH, 85°C, 1000hrs.

**Thermal Shock:** MIL-STD-202, Method 107G, -65°C to 125°C, 30 min cycle, 10 cycles.

**Vibration:** MIL-STD-202F, Method 201A, (10 to 55 to 10Hz, 1 min. cycle, 2grs each in X-Y-Z)

**Chemical Resistance:** ASTM D-543, 4hrs @ 40°C, 3 solutions (H<sub>2</sub>O, detergent solution, defluxer)

**Solder leach resistance and terminal adhesion:** Per EIA-576 test

#### Physical Specifications

##### Materials:

Body: Glass Epoxy

Terminations: Copper/Nickel/Tin/Lead

##### Solderability:

MIL-STD-202, Method 208 (95% coverage)

##### Soldering Parameters:

Wave Solder – 260°C, 10 seconds maximum.

Reflow Solder – 260°C, 30 seconds maximum.

#### Packaging Specifications

8mm Tape and Reel per EIA-RS481-1 (IEC 286, part3); 1,000 pieces per reel, add packaging suffix, MR; 5,000 per reel, add packaging suffix NR.

#### Capacitance vs. Frequency

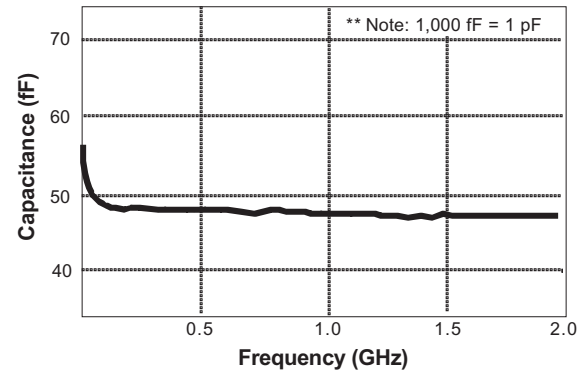

#### Carrier Tape Specifications

Parts are delivered on 7" (178mm) reel, paper carrier tape

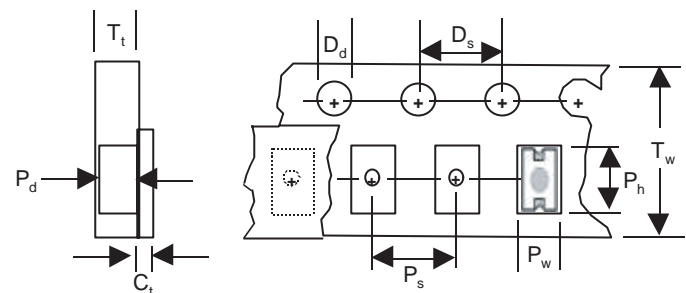

DESCRIPTION	MEASUREMENT (MM)
C <sub>t</sub> - Cover tape thickness	0.06
D <sub>d</sub> - Drive hole diameter	1.50
D <sub>s</sub> - Drive hole spacing	4.00
P <sub>d</sub> - Pocket depth	0.58
P <sub>h</sub> - Pocket height	1.85
P <sub>s</sub> - Pocket spacing	4.00
P <sub>w</sub> - Pocket width	1.02
T <sub>t</sub> - Carrier tape thickness	0.65
T <sub>w</sub> - Carrier tape width	8.00

# PulseGuard® Suppressors

## Surface Mount Polymeric ESD Suppressors

### PGB Series SOT23 ESD Suppressor

#### Product Overview

PulseGuard ESD Suppressors help protect sensitive electronic equipment against electrostatic discharge (ESD). They supplement the on-chip protection of integrated circuitry and are best suited for low-voltage, high-speed applications where low capacitance is important. Data ports utilizing such high-speed protocols as USB 2.0, IEEE1394 and InfiniBand<sup>SM</sup> can benefit from this new technology. PulseGuard suppressors use polymer composite materials to suppress fast-rising ESD transients (as specified in IEC 61000-4-2 and MIL-STD-883E).

#### Features

- Ultra-low capacitance
- Low leakage current
- Fast response time
- 2-lines of protection
- Bi-directional
- Withstands multiple ESD strikes
- Standard JEDEC SOT23 outline
- Compatible with pick-and-place processes
- Available in 3,000 piece reels

#### Typical Applications

- Servers
- Laptop/Desktop Computers
- Network Hardware
- Computer Peripherals
- Digital Cameras
- External Storage

#### Ordering Information

CATALOG NUMBER	PIECES PER REEL
PGB002ST23WR	3,000

#### Design Consideration

Because of the fast rise-time of the ESD transient, placement of PulseGuard suppressors is a key design consideration. To achieve optimal ESD suppression, the devices should be placed on the circuit board as close to the source of the ESD transient as possible. Install PulseGuard suppressors directly behind the connector so that they are the first board-level circuit component encountered by the ESD transient. They are connected from signal/data line to ground.



#### Reference Dimensions:

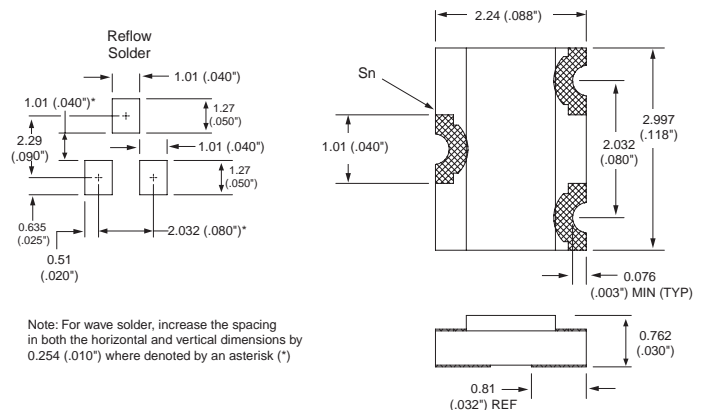

#### Equivalent Circuit

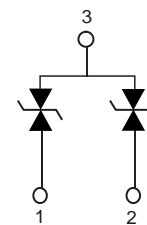

# PulseGuard® Suppressors

## Surface Mount Polymeric ESD Suppressors

### PGB Series SOT23 ESD Suppressor

#### Electrical Characteristics

##### ESD Capability

IEC 61000-4-2 Direct Discharge .....	8kV
IEC 61000-4-2 Air Discharge .....	15kV
Trigger Voltage <sup>1</sup> .....	1,000V typical
Clamping Voltage <sup>1</sup> .....	150V typical
Rated Voltage .....	24VDC max
Capacitance <sup>2</sup> .....	0.055pF
Response Time <sup>1</sup> .....	<1ns
Leakage Current <sup>3</sup> .....	<1nA
ESD Pulse Withstand <sup>4</sup> .....	1,000 pulses minimum

##### Notes:

1. Trigger and clamping voltage measured per IEC 61000-4-2, 8kV direct discharge method.
2. Capacitance measured at 1MHz.
3. Leakage current measured at 6VDC.
4. Pulse Withstand- some shifting in characteristics may occur when tested over multiple pulses at a very rapid rate.

#### Environmental Specifications

**Operating Temperature:** -65°C to +125°C.

**Moisture Resistance, steady state:** MIL-STD-883, method 1004.7, 85% RH, 85°C, 1000hrs.

**Thermal Shock:** MIL-STD-202, Method 107G, -65°C to 125°C, 30 min cycle, 10 cycles.

**Vibration:** MIL-STD-202F, Method 201A, (10 to 55 to 10Hz, 1 min. cycle, 2grs each in X-Y-Z)

**Chemical Resistance:** ASTM D-543, 4hrs @ 40°C, 3 solutions (H<sub>2</sub>O, detergent solution, defluxer)

**Solder leach resistance and terminal adhesion:** Per EIA-576 test

#### Physical Specifications

##### Materials:

Body: Glass Epoxy

Terminations: Copper/Nickel/Tin/Lead

**Solderability:** MIL-STD-202, Method 208 (95% coverage)

##### Soldering Parameters:

Wave Solder – 260°C, 10 seconds maximum.

Reflow Solder – 260°C, 30 seconds maximum.

#### Packaging Specifications

8mm Tape and Reel per EIA-RS481-1 (IEC 286, part3); 3,000 pieces per reel, add packaging suffix, WR.

#### Capacitance vs. Frequency

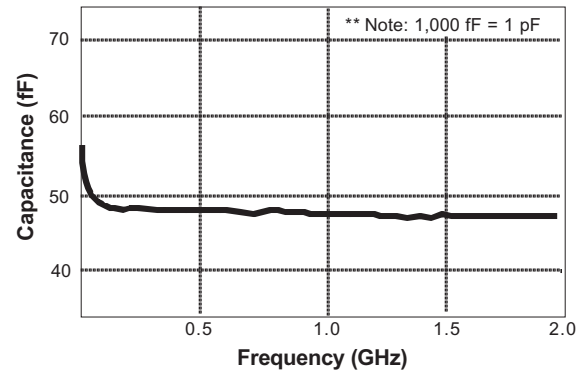

#### Carrier Tape Specifications

Parts are delivered on 7" (178mm) reel, plastic carrier tape

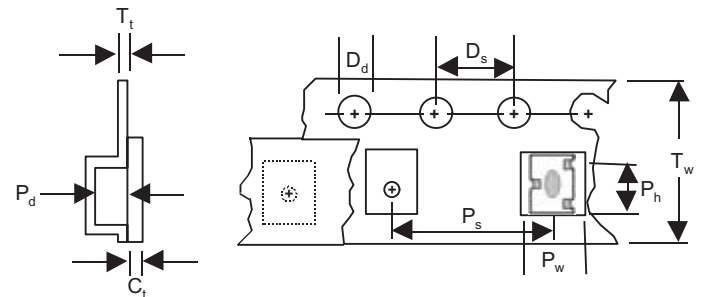

DESCRIPTION	MEASUREMENT (MM)
C <sub>t</sub> - Cover tape thickness	0.06
D <sub>d</sub> - Drive hole diameter	1.50
D <sub>s</sub> - Drive hole spacing	4.00
P <sub>d</sub> - Pocket depth	1.02
P <sub>h</sub> - Pocket height	3.23
P <sub>s</sub> - Pocket spacing	4.00
P <sub>w</sub> - Pocket width	2.46
T <sub>t</sub> - Carrier tape thickness	0.30
T <sub>w</sub> - Carrier tape width	8.00

# PulseGuard® Suppressors

## Surface Mount Polymeric ESD Suppressors

### PGB Series 0805 ESD Suppressor

#### Product Overview

PulseGuard ESD Suppressors help protect sensitive electronic equipment against electrostatic discharge (ESD). They supplement the on-chip protection of integrated circuitry and are best suited for low-voltage, high-speed applications where low capacitance is important. Data ports utilizing such high-speed protocols as USB 2.0, IEEE1394 and InfiniBand<sup>SM</sup> can benefit from this new technology. PulseGuard suppressors use polymer composite materials to suppress fast-rising ESD transients (as specified in IEC 61000-4-2 and MIL-STD-883E).

#### Features

- Ultra-low capacitance
- Low leakage current
- Fast response time
- 4-lines of protection
- Bi-directional
- Withstands multiple ESD strikes
- Based on industry standard 2012 package
- Compatible with pick-and-place processes
- Available in 1,000 and 5,000 piece reels (EIA-RS481)

#### Typical Applications

- Servers
- Laptop/Desktop Computers
- Network Hardware
- Computer Peripherals
- Digital Cameras
- External Storage

#### Ordering Information

CATALOG NUMBER	PIECES PER REEL
PGB0040805MR	1,000
PGB0040805NR	5,000

#### Design Consideration

Because of the fast rise-time of the ESD transient, placement of PulseGuard suppressors is a key design consideration. To achieve optimal ESD suppression, the devices should be placed on the circuit board as close to the source of the ESD transient as possible. Install PulseGuard suppressors directly behind the connector so that they are the first board-level circuit component encountered by the ESD transient. They are connected from signal/data line to ground.

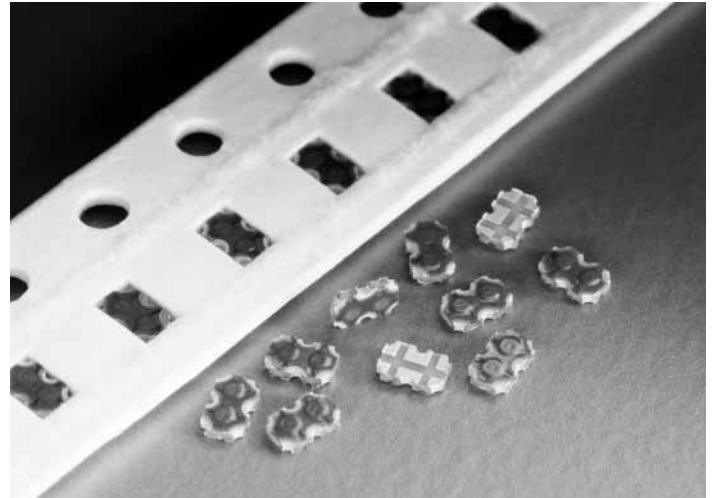

#### Reference Dimensions:

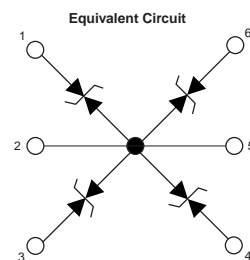
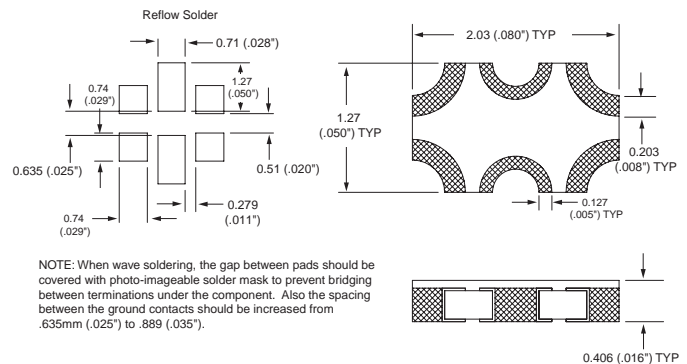

# PulseGuard® Suppressors

## Surface Mount Polymeric ESD Suppressors

### PGB Series 0805 ESD Suppressor

#### Electrical Characteristics

##### ESD Capability

IEC 61000-4-2 Direct Discharge .....	8kV
IEC 61000-4-2 Air Discharge .....	15kV
Trigger Voltage <sup>1</sup> .....	1,000 V, typical
Clamping Voltage <sup>1</sup> .....	150V, typical
Rated Voltage .....	24VDC, max
Capacitance <sup>2</sup> .....	0.055 pF
Response Time <sup>1</sup> .....	< 1ns
Leakage Current <sup>3</sup> .....	< 1nA
ESD Pulse Withstand <sup>4</sup> .....	1,000 pulses, minimum

##### Notes:

1. Trigger and clamping voltage measured per IEC 61000-4-2, 8kV direct discharge method.
2. Capacitance measured at 1MHz.
3. Leakage current measured at 6VDC.
4. Pulse Withstand- some shifting in characteristics may occur when tested over multiple pulses at a very rapid rate.

#### Environmental Specifications

**Operating Temperature:** -65°C to +125°C.

**Moisture Resistance, steady state:** MIL-STD-833, method 1004.7, 85% RH, 85°C, 1000hrs.

**Thermal Shock:** MIL-STD-202, Method 107G, -65°C to 125°C, 30 min cycle, 10 cycles.

**Vibration:** MIL-STD-202F, Method 201A, (10 to 55 to 10Hz, 1 min. cycle, 2grs each in X-Y-Z)

**Chemical Resistance:** ASTM D-543, 4hrs @ 40°C, 3 solutions (H<sub>2</sub>O, detergent solution, defluxer)

**Solder leach resistance and terminal adhesion:** Per EIA-576 test

#### Physical Specifications

##### Materials:

Body: Glass Epoxy

Terminations: Copper/Nickel/Tin/Lead

**Solderability:** MIL-STD-202, Method 208 (95% coverage)

##### Soldering Parameters:

Wave Solder – 260°C, 10 seconds maximum.

Reflow Solder – 260°C, 30 seconds maximum.

#### Packaging Specifications

8mm Tape and Reel per EIA-RS481-1 (IEC 286, part3); 1,000 pieces per reel, add packaging suffix, MR; 5,000 per reel, add packaging suffix NR.

#### Capacitance vs. Frequency

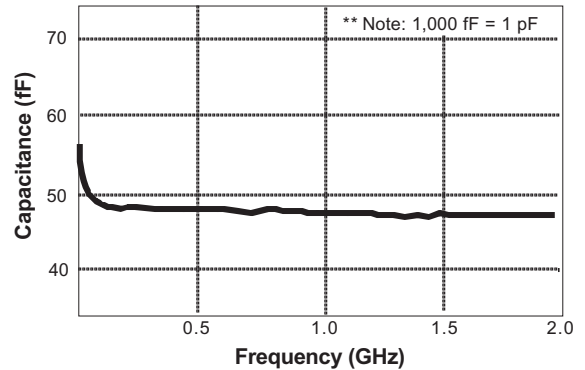

#### Carrier Tape Specifications

Parts are delivered on 7" (178mm) reel, paper carrier tape

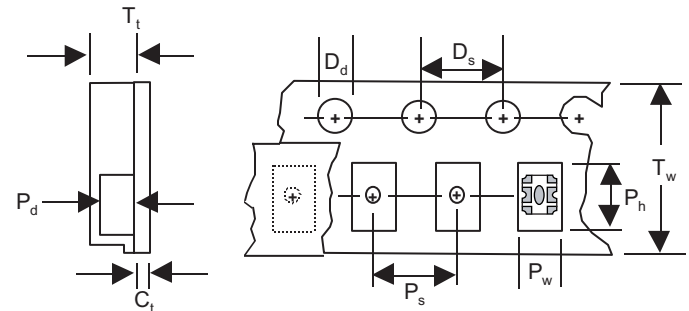

DESCRIPTION	MEASUREMENT (MM)
C <sub>t</sub> - Cover tape thickness	0.06
D <sub>d</sub> - Drive hole diameter	1.50
D <sub>s</sub> - Drive hole spacing	4.00
P <sub>d</sub> - Pocket depth	0.58
P <sub>h</sub> - Pocket height	2.21
P <sub>s</sub> - Pocket spacing	4.00
P <sub>w</sub> - Pocket width	1.45
T <sub>t</sub> - Carrier tape thickness	0.65
T <sub>w</sub> - Carrier tape width	8.00

# PulseGuard® Suppressors

## Connector Array Polymeric ESD Suppressors

### PGD Series ESD Suppressor

With similar performance features as the surface mount ESD products, the connector array products provide the first line of defense against ESD events. For use in standard D-Subminiatures, these suppressors intercept the ESD pulses before they enter the electronic equipment. The pulses are shunted to the grounded shell of the connector and kept off of the circuit board. The connector configuration takes up zero board space and can also be used as a retrofit solution in cases where the ESD problem was identified after the board design was complete.

#### Electrical Characteristics:

- Capacitance <math><2\text{ pF}^1</math>
- Leakage Current <math><0.1\mu\text{A}^2</math>
- Off state Resistance 10 M $\Omega^2$
- Clamping Voltage 100V<sup>3</sup>, typical
- Operating Voltage 24 VDC
- Peak Current 45A, at 15 kV
- Bi-directional
- Product Rated for 10,000 cycles

#### PHYSICAL SPECIFICATIONS:

**Body Material:** Polyimide

**Terminations:** Spring contacts

**Voltage Variable Material:** Littelfuse polymeric formula.

#### Soldering Parameters:

- Press-in fitting, soldering not necessary.

**Packaging:** Bulk, bagged and tagged.

#### ENVIRONMENTAL SPECIFICATIONS:

**Operating Temperature:** -65°C to 125°C

**Vibration:** Withstands 10-55Hz per MIL-STD-202F, Method 201A and 10-2000Hz at 20 G's per MIL-STD-202F, Method 204D, Condition D.

**Thermal Shock:** Withstands 5 cycles of -50°C to 125°C

#### ORDERING INFORMATION:

<sup>1</sup> Tested at 1 Megahertz

<sup>2</sup> Tested at 5 VDC

<sup>3</sup> Tested at 8 kV, Direct Contact, IEC 61000-4-2 ESD Waveform

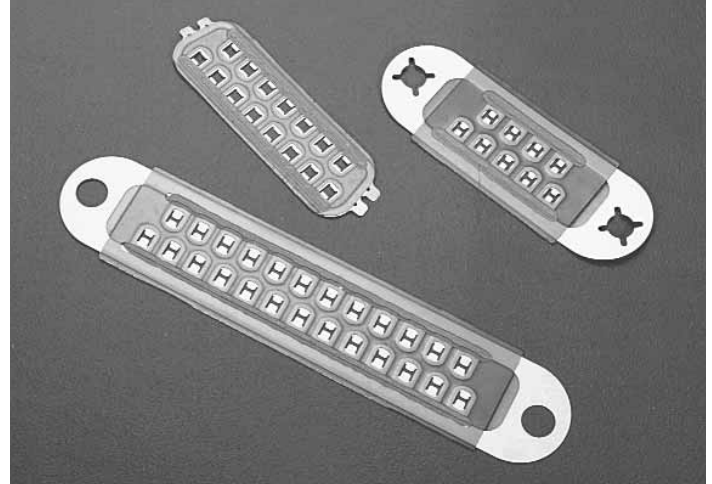

90° Angle Mount

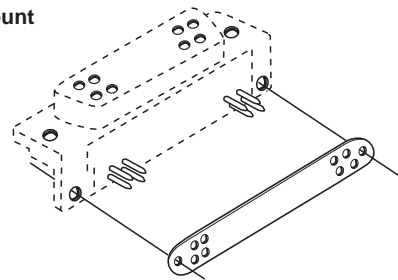

Front Mount

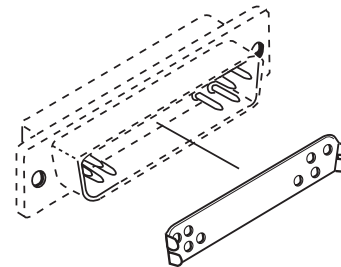

Catalog Number	Mounting Option	Number of Pins	Pin Size (in.)
PGD009S030BSA01	90° Angle	9	0.018 - 0.028
PGD009S030CSA01	90° Angle	9	0.030 - 0.040
PGD009S030CSF01	Front	9	0.030 - 0.040
PGD009S030BSR01	Rear	9	0.018 - 0.028
PGD015S030BSA01	90° Angle	15	0.018 - 0.028
PGD015S030CSA01	90° Angle	15	0.030 - 0.040
PGD015S030CSF01	Front	15	0.030 - 0.040
PGD015S030BSR01	Rear	15	0.018 - 0.028
PGD025S030BSA01	90° Angle	25	0.018 - 0.028
PGD025S030CSA01	90° Angle	25	0.030 - 0.040
PGD025S030CSF01	Front	25	0.030 - 0.040
PGD025S030BSR01	Rear	25	0.018 - 0.028
PGD037S030BSA01	90° Angle	37	0.018 - 0.028
PGD037S030CSA01	90° Angle	37	0.030 - 0.040
PGD037S030CSF01	Front	37	0.030 - 0.040

# **PulseGuard® Suppressors**

*Polymeric ESD Suppressors*

---

Notes and Drawings

---

4

PULSEGUARD®  
SUPPRESSORS

