

PGR-6200 MANUAL
MOTOR PROTECTION RELAY

June 1, 2009

Revision 2

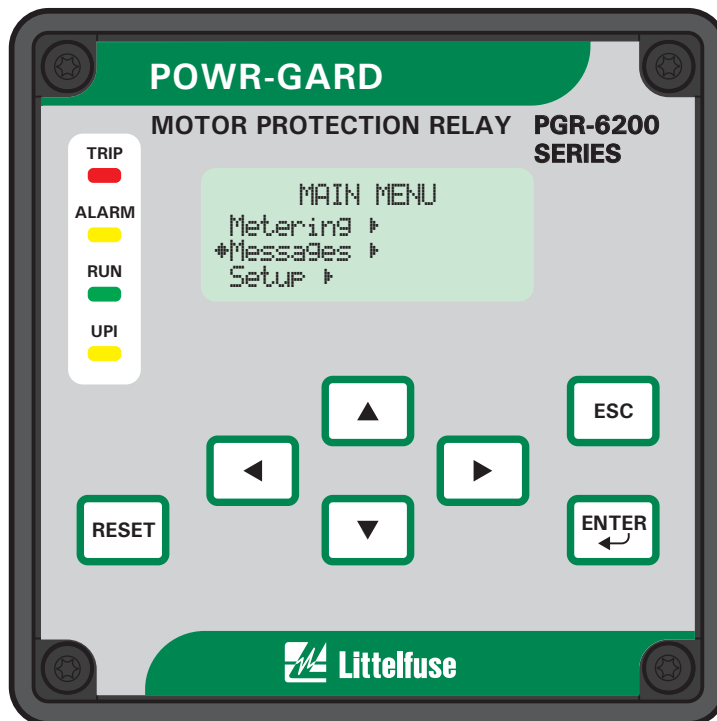

Copyright © 2009 by Littelfuse, Inc.
All rights reserved.

Factory default password is 1111

New Password
See Section 4.5

Motor Identification

TABLE OF CONTENTS

	<i>Page</i>		<i>Page</i>
Table of Contents.....	i	4.2 Setup	4-2
List of Figures.....	ii	4.2.1 Phase-CT Inputs.....	4-2
List of Tables.....	ii	4.2.2 Earth-Fault-CT Input.....	4-2
1. INTRODUCTION.....	1-1	4.2.3 Motor Data	4-2
1.1 General	1-1	4.2.4 Output Relay Assignment	4-3
1.2 PGR-6200 Features	1-1	4.2.5 Digital Input	4-3
1.2.1 Protection	1-1	4.2.6 Analog Output.....	4-4
1.2.2 Metering.....	1-1	4.2.7 Miscellaneous Configuration.....	4-4
1.2.3 Data Logging.....	1-1	4.2.8 Communications.....	4-4
1.2.4 Inputs and Outputs.....	1-1	4.3 Metering.....	4-5
1.2.5 Operator Interface.....	1-1	4.4 Messages	4-5
1.2.6 PGA-0120 Temperature Input Module (Optional)	1-1	4.4.1 Trip Reset.....	4-5
1.2.7 PGA-0140 Differential Current Module (Optional).....	1-1	4.4.2 Data Logging.....	4-5
1.2.8 Communications	1-1	4.4.3 Statistical Data	4-6
1.3 Ordering Information	1-1	4.4.4 Emergency Thermal Reset	4-6
2. INSTALLATION.....	2-1	4.5 Password Entry and Programming	4-6
2.1 General	2-1	4.6 PGA-0120.....	4-7
2.2 PGR-6200 Motor Protection Relay.....	2-1	4.7 PGA-0140.....	4-7
2.3 PGA-0CIM Current Input Module	2-1	5. PROTECTIVE FUNCTIONS.....	5-1
2.4 Sensitive Earth-Fault CT's	2-1	5.1 General	5-1
2.5 PGA-0120 Temperature Input Module.....	2-1	5.2 Overload.....	5-1
2.6 PGA-0140 Differential Current Module	2-1	5.2.1 Thermal Model	5-1
3. SYSTEM WIRING.....	3-1	5.2.2 Locked-Rotor Times.....	5-4
3.1 General	3-1	5.2.3 Emergency Thermal Reset	5-4
3.2 Wiring Connections	3-2	5.3 Overcurrent	5-4
3.2.1 PGR-6200 Connections	3-2	5.4 Auxiliary Overcurrent.....	5-5
3.2.1.1 Supply Voltage	3-2	5.5 Reduced Overcurrent.....	5-5
3.2.1.2 CIM Input.....	3-2	5.6 Jam	5-5
3.2.1.3 Digital Input.....	3-2	5.7 Earth Fault.....	5-5
3.2.1.4 Analog Output	3-2	5.8 Current Unbalance.....	5-6
3.2.1.5 PTC or RTD Input (Local).....	3-2	5.9 Phase Loss	5-6
3.2.1.6 I/O Module Interface	3-2	5.10 Phase Reverse.....	5-6
3.2.1.7 RS/EIA/TIA-232 Communications	3-3	5.11 Undercurrent	5-6
3.2.2 PGA-0CIM Connections	3-3	5.12 Differential Current Protection.....	5-6
3.2.2.1 Standard.....	3-4	5.13 Starts per Hour/Time Between Starts	5-7
3.2.2.2 Residual Earth-Fault	3-4	5.14 PTC Temperature (Local)	5-7
3.2.2.3 Two-CT.....	3-4	5.15 RTD Temperature (Local)	5-7
3.2.3 PGA-0120 Connections and Address Selection.....	3-6	5.16 RTD Temperature (PGA-0120 Module).....	5-8
3.2.4 PGA-0140 Connections.....	3-6	5.17 Hot-Motor Compensation	5-8
3.2.4.1 Core Balance.....	3-6	6. THEORY OF OPERATION.....	6-1
3.2.4.2 PGR-6200 Summation	3-6	6.1 Signal-Processing Algorithms	6-1
3.2.4.3 DIF Summation	3-6	6.2 Temperature Input Module (PGA-0120)	6-1
3.2.5 Cable Restraint	3-6	6.3 Differential Current Module (PGA-0140).....	6-1
3.2.6 Dielectric-Strength Testing	3-6	7. COMMUNICATIONS.....	7-1
4. OPERATION AND SETUP.....	4-1	7.1 Personal-Computer Interface.....	7-1
4.1 Display and Indication	4-1	7.1.1 Firmware Upgrade.....	7-1
4.1.1 Front-Panel LED Indication	4-1	7.1.2 PGW-COMM	7-1
4.1.2 Rear-Panel LED Indication.....	4-2	7.2 Network Interface	7-1
4.1.3 Display Contrast and Test	4-2	7.2.1 TIA-485 Option	7-1
		7.2.2 DeviceNet Option	7-1
		7.2.3 Ethernet Option	7-1

	<i>Page</i>
8. TECHNICAL SPECIFICATIONS	8-1
8.1 PGR-6200.....	8-1
8.2 Current Input Module (PGR-0CIM).....	8-3
8.3 Temperature Input Module (PGA-0120).....	8-3
8.4 Differential Current Module (PGA-0140).....	8-4
Appendix A PGR-6200 Menu Map.....	A-1
Appendix B PGR-6200 Setup Record.....	B-1
Appendix C Not Used.....	C-1
Appendix D PGR-6200 TIA-232 Modbus Protocol.....	D-1
Appendix E Communications Database Table.....	E-1
Appendix F Register Formats.....	F-1
Appendix G Ground-Fault Performance Test.....	G-1

LIST OF FIGURES

	<i>Page</i>
1.1 Motor Protection Relay Block Diagram.....	1-2
1.2 PGR-6200 Ordering Information.....	1-3
2.1 PGR-6200 Outline and Panel-Mounting Details.....	2-2
2.2 PGR-6200 Outline and Surface-Mounting Details.....	2-3
2.3 PGA-0CIM Outline and Mounting Details.....	2-4
2.4 PGC-3082 Outline and Mounting Details.....	2-5
2.5 PGC-3140 Outline and Mounting Details.....	2-6
2.6 PGC-3026 Outline and Mounting Details.....	2-7
2.7 PGA-0120 Outline and Mounting Details.....	2-8
2.8 PGA-0140 Outline and Mounting Details.....	2-9
3.1 Typical PGR-6200 Connection Diagram.....	3-1
3.2 Analog-Output Connections.....	3-2
3.3 Local Temperature-Sensor Connections.....	3-2
3.4 I/O Module Connection Diagram.....	3-2
3.5 PGA-0CIM Schematic.....	3-3
3.6 PGA-0CIM Standard Connections.....	3-4
3.7 Other PGA-0CIM Connections.....	3-5
3.8 PGA-0120 Connection Diagram.....	3-7
3.9 Core-Balance Connection.....	3-7
3.10 PGR-6200-Summation Connection.....	3-8
3.11 PGA-0140-Summation Connections.....	3-8
4.1 Menu Example.....	4-1
4.2 Menu Symbols.....	4-1
5.1 Class-20 Overload Curve.....	5-3
5.2 Asymmetrical-Current Multipliers.....	5-5
5.3 Used I^2t Bias Curve.....	5-8

LIST OF TABLES

	<i>Page</i>
3.1 PGA-0420 Adapter Pinout.....	3-3
3.2 PGA-0120 Address Selection.....	3-6
4.1 UPI LED Functions.....	4-1
4.2 Output-Relay Functions.....	4-3
4.3 Digital-Input Functions.....	4-3
4.4 Analog-Output Parameters.....	4-4
4.5 Metering Display.....	4-5
5.1 Fault Duration Required for Trip or Alarm.....	5-4

DISCLAIMER

Specifications are subject to change without notice. Littelfuse, Inc. is not liable for contingent or consequential damages, or for expenses sustained as a result of incorrect application, incorrect adjustment, or a malfunction.

This product has a variety of applications. Those responsible for its application must take the necessary steps to assure that each installation meets all performance and safety requirements including any applicable laws, regulations, codes, and standards.

Information provided by Littelfuse is for purposes of example only. Littelfuse does not assume responsibility for liability for use based upon the examples shown.

1. INTRODUCTION

1.1 General

The POWR-GARD[®] PGR-6200 is a motor-protection relay that provides integrated protection, metering, and data-logging functions for fixed- and variable-frequency applications. The PGR-6200 can be programmed using the front-panel operator interface, the TIA-232 port, or an optional communications network.

The PGR-6200 uses a PGA-0CIM current-input module for current-transformer connections as shown in Fig. 1.1. Each PGR-6200 includes a PGA-0CIM.

1.2 PGR-6200 Features

1.2.1 Protection

- Overload (49, 51)
- Overcurrent (50, 51)
- Earth fault (50G/N, 51G/N)
- Unbalance (46)
- Phase loss (46)
- Phase reverse (46)
- Jam
- Undercurrent (37)
- Starts per hour (66)
- Differential (87)
- PTC overtemperature (49)
- RTD temperature (38, 49)

1.2.2 Metering

- Line currents
- Current unbalance
- Positive-sequence current (I_1)
- Negative-sequence current (I_2)
- Zero-sequence current ($3I_0$, calculated)
- Earth-leakage current (CT input)
- Differential currents
- Used thermal capacity
- Thermal trend
- RTD temperatures
- Frequency

1.2.3 Data Logging

- One-hundred records
 - Date and time of event
 - Event type
 - Cause of trip
 - Line currents
 - Current unbalance
 - Earth-leakage current
 - Differential currents
 - Used thermal capacity

- Thermal capacity used during starts
- Start time
- RTD temperatures
- Trip counters
- Running hours

1.2.4 Inputs and Outputs

- Phase-current inputs
- Earth-leakage-current input
- Programmable digital input (24 Vdc)
- 24-Vdc source for digital input
- 4–20-mA analog output, programmable
- Temperature-sensor input, Pt100 RTD or PTC
- I/O module interface
- Three output relays, programmable
- TIA-232 communications
- Network communications

1.2.5 Operator Interface

- 4 x 20 backlit LCD display
- Display-control and programming keys
- LED status indication

1.2.6 PGA-0120 Temperature Input Module (Optional)

- Eight-RTD inputs per module
- Individually selectable RTD types
- Solid-state multiplexing
- Up to three modules per system
- Remote operation up to 1.2 km (4,000')
- Powered by PGR-6200

1.2.7 PGA-0140 Differential Current Module (Optional)

- 3-CT core balance connection
- 6-CT summation connection
- Remote operation up to 1.2 km (4,000')
- Powered by PGR-6200

1.2.8 Communications

The standard communications interface is a TIA-232 port using the Modbus[®] RTU protocol. In addition to the standard interface, network communications options include TIA-485 with both Modbus[®] RTU and A-B[®] DF1 protocols, DeviceNet[™], and an IEEE 802.3 port with Modbus[®] TCP Ethernet protocol.

1.3 Ordering Information

See Fig. 1.2 for PGR-6200, PGA-0CIM, PGA-0120 and PGA-0140 model numbers.

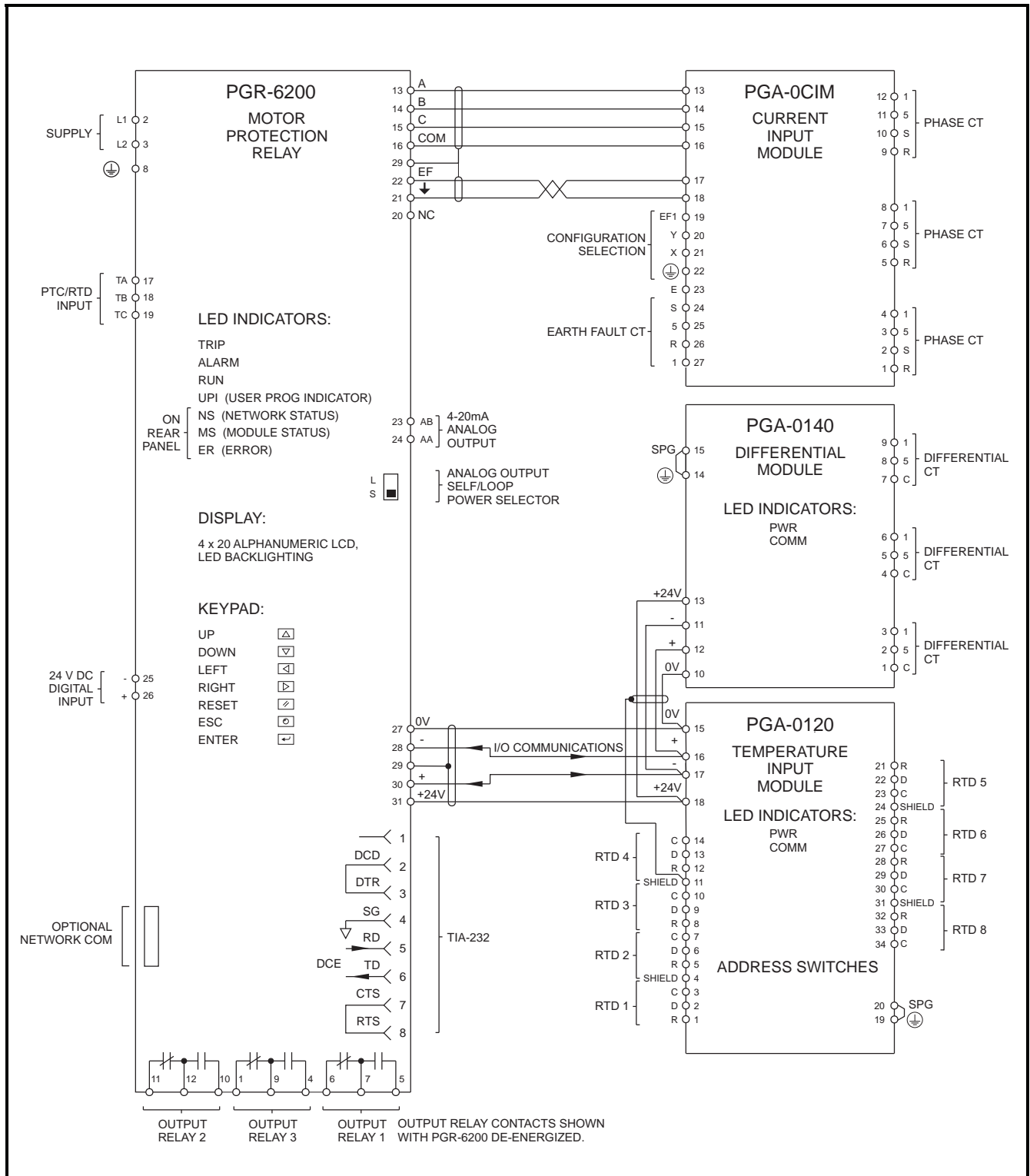
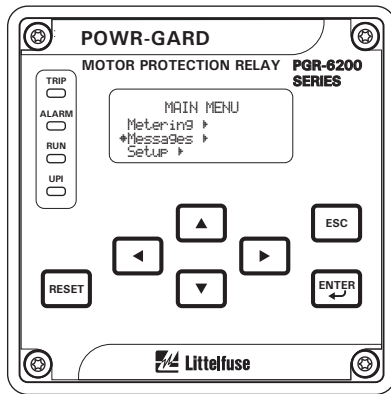
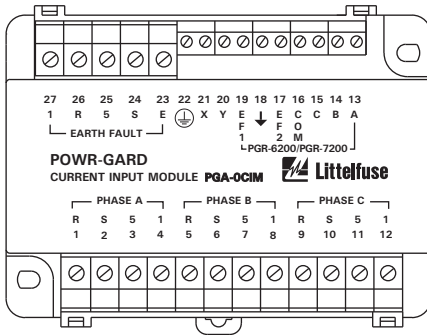

FIGURE 1.1 Motor Protection Relay Block Diagram.



PGR-6200- [] - []

- Options:
00 CIM Input
- Network Communications:
0 None, TIA-232 only
1 TIA-485 c/w A-B® DF1 & Modbus® RTU Protocols
2 DeviceNet™
4 IEEE 802.3 (Ethernet)
- Power Supply:
0 Universal ac/dc (65 to 265 Vac and 80 to 275 Vdc)



PGA-0CIM

NOTE:

The PGR-6200 consists of the Motor Protection Relay and the PGA-0CIM Current Input Module. To order the relay only, add (-MPU) to the part number listed above.

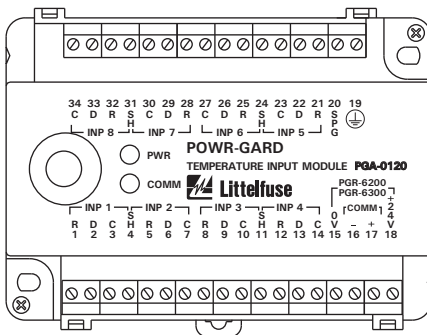

PGA-0120

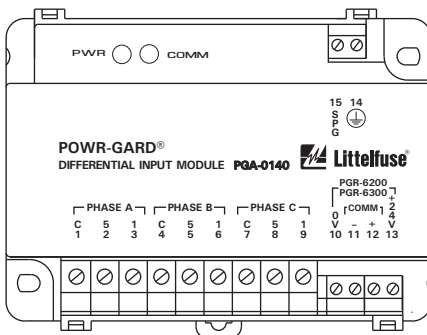

PGA-0140

Supplied Interconnect Cable:

- P75-P300-20030 . . . PGA-0CIM to PGR-6200 Interconnect Cable, 6 m (19') Included with PGA-0CIM
3124A I/O Module to PGR-6200 Interconnect Cable, 4 m (13') Included with PGA-0120 and PGA-0140

FIGURE 1.2 PGR-6200 Ordering Information.



Current Transformers:

- PGC-3026 Sensitive Earth-Fault CT,
5-A-primary rating,
26-mm (1") window
- PGC-3082 Sensitive Earth-Fault CT,
5-A-primary rating,
82-mm (3.2") window
- PGC-31FC Flux Conditioner for
PGC-3082,
70-mm (2.7") window
- PGC-3140 Sensitive Earth-Fault CT
with Flux Conditioner,
5-primary rating,
139-mm (5.5") window
- Other Earth-Fault CT's Contact factory
- Phase CT's Contact factory

Accessories:

- PGK-0SMK Surface-mounting
hardware kit
- PGA-016A Watertight faceplate cover
- PGA-0420 DB9 to RJ-45 Adaptor with
1.5 m (5') cable
- PGA-0440 USB to TIA-232 serial
converter

Software:

- PGW-COMM PC Interface ⁽¹⁾
- PGW-FLSH Firmware Upgrade ⁽¹⁾

⁽¹⁾ Available at www.littelfuse.com/protectionrelays

2. INSTALLATION

2.1 General

A basic system consists of a PGR-6200, a PGR-0CIM, and three 1-A- or 5-A-secondary line-current transformers. Earth-fault protection can be provided from a core-balance CT or from phase CT's. A core-balance CT (1-A, 5-A, or PGC-3000 series) is recommended. In addition to a single PTC/RTD input provided on the PGR-6200, up to three PGA-0120 modules (eight RTD inputs per module) and one PGA-0140 differential module can be connected to a PGR-6200.

The PGR-6200 switch-mode power supply is rated 65 to 265 Vac and 80 to 275 Vdc.

All modules can be mounted in any orientation.

2.2 PGR-6200 Motor Protection Relay

Outline and details for PGR-6200 panel-mounting are shown in Fig. 2.1. The PGR-6200 mounts in a 92 mm (3.62") ¼ DIN square cutout and is secured by a panel-mount clamp. Insert the PGR-6200 through the panel cutout and slip the panel-mount clamp over the PGR-6200 body. Slide the clamp forward until the latch tabs snap into the mating holes. Lock the unit in place by tightening the four clamp screws against the panel.

Caution:

Do not over tighten the clamp screws as this may deform the clamp and release the latch tabs.

Outline and details for PGR-6200 surface-mounting are shown in Fig. 2.2. Ensure that the L/S switch is set before installing surface-mounting brackets. See Section 3.2.1.4 for switch positions. A detailed installation instruction sheet is included with the PGK-OSMK, Surface-Mounting Hardware Kit.

2.3 PGA-0CIM Current Input Module

The PGA-0CIM can be surface or DIN-rail mounted. Outline and mounting details are shown in Fig. 2.3. To minimize CT-lead burden, a PGA-0CIM can be located close to the CT's. The PGA-0CIM terminates phase- and earth-fault-CT secondaries—shorting blocks are not required for PGA-0CIM outputs.

2.4 Sensitive Earth-Fault CT's

Outline and mounting details for the PGC-3026, PGC-3082, and PGC-3140 are shown in Figs. 2.4, 2.5, and 2.6.

2.5 PGA-0120 Temperature Input Module

Outline and mounting details for the PGA-0120 are shown in Fig. 2.7. The PGA-0120 will fit inside most motor RTD-termination junction boxes and it is certified for use in Class I, Zone 2 hazardous locations. The PGA-0120 can be surface or DIN-rail mounted.

2.6 PGA-0140 Differential Current Module

Outline and mounting details for the PGA-0140 are shown in Fig 2.8. The PGA-0140 can be surface or DIN-rail mounted.

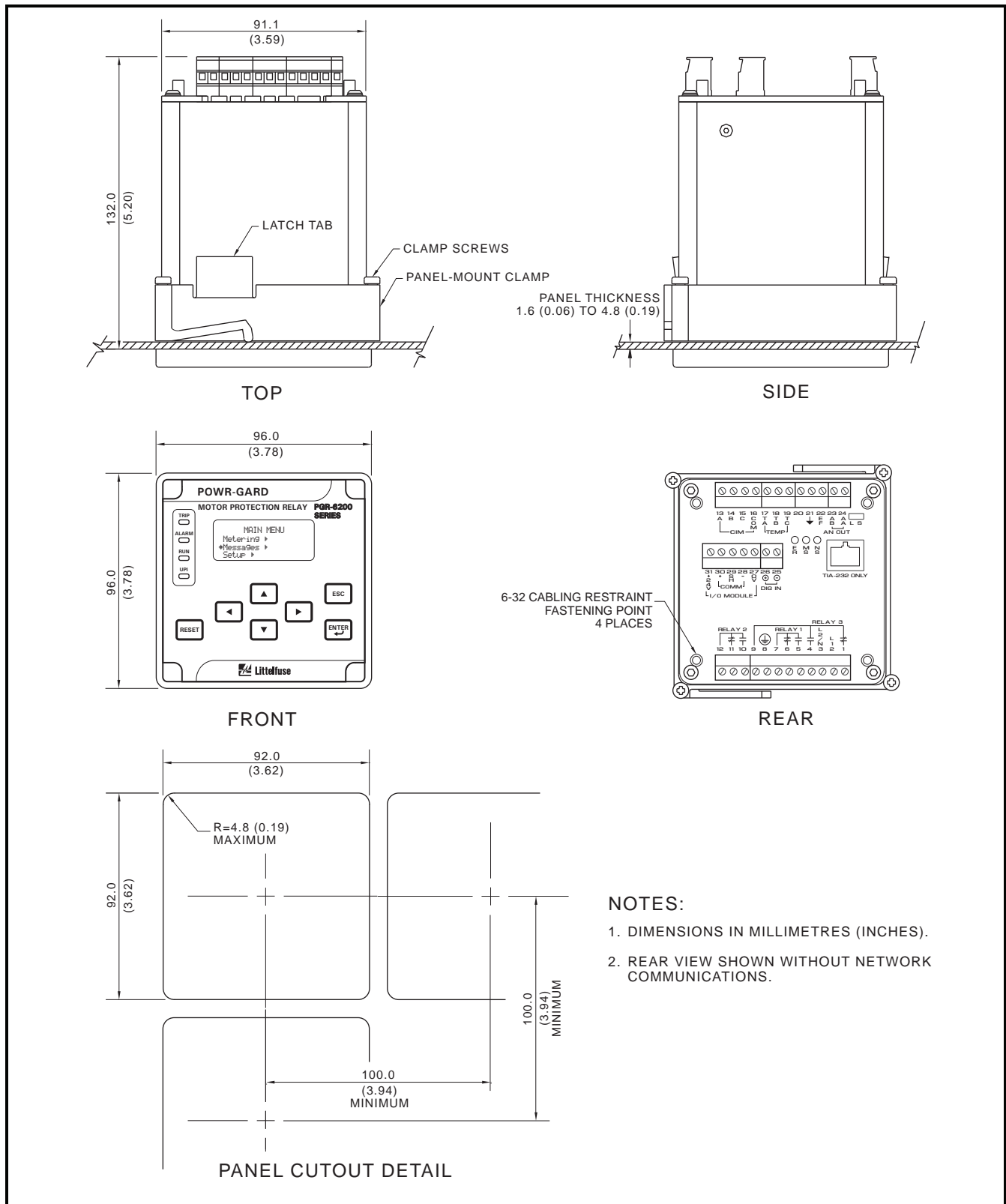

FIGURE 2.1 PGR-6200 Outline and Panel-Mounting Details.

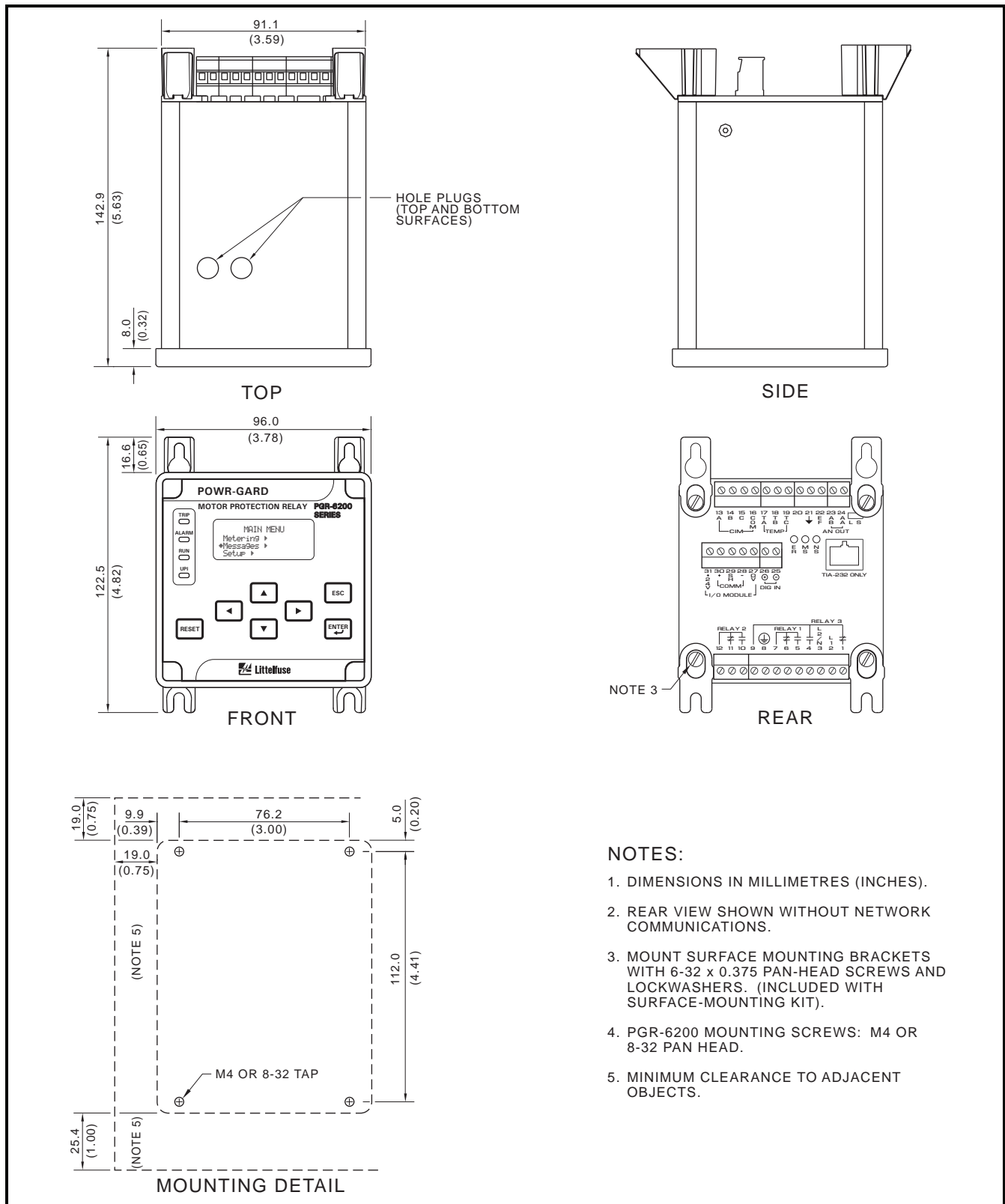

FIGURE 2.2 PGR-6200 Outline and Surface-Mounting Details.

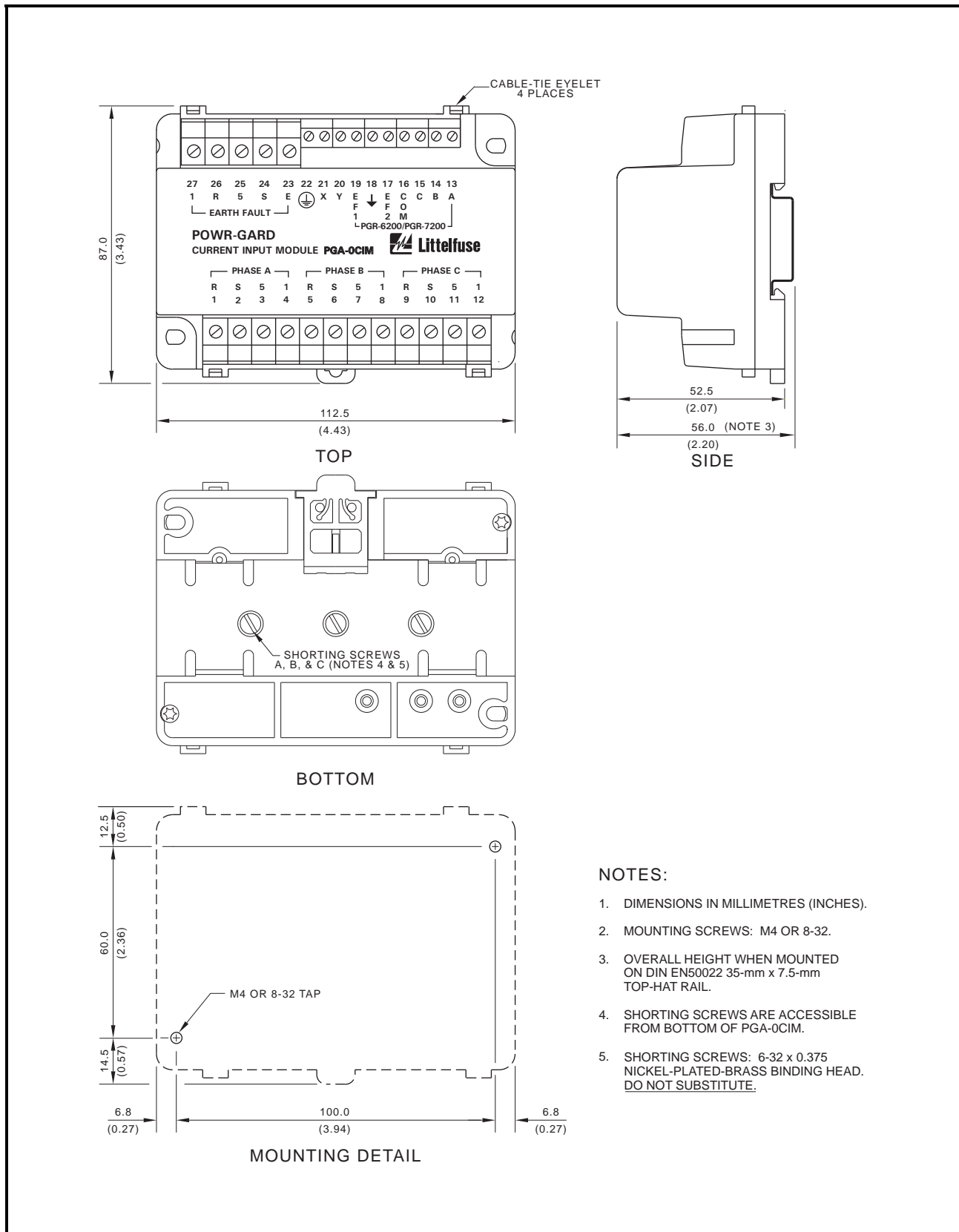

FIGURE 2.3 PGA-0CIM Outline and Mounting Details.

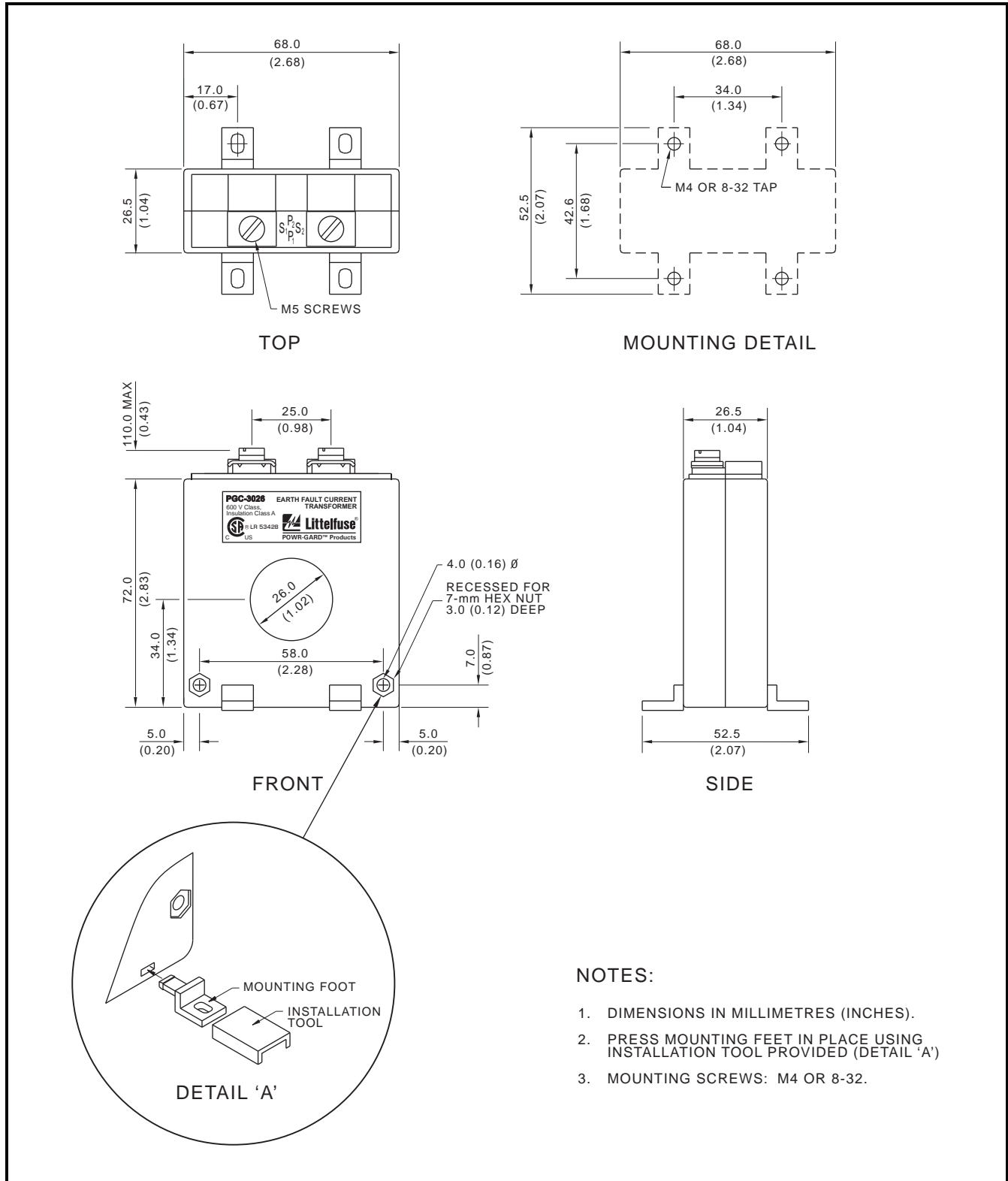

FIGURE 2.4 PGC-3026 Outline and Mounting Details.

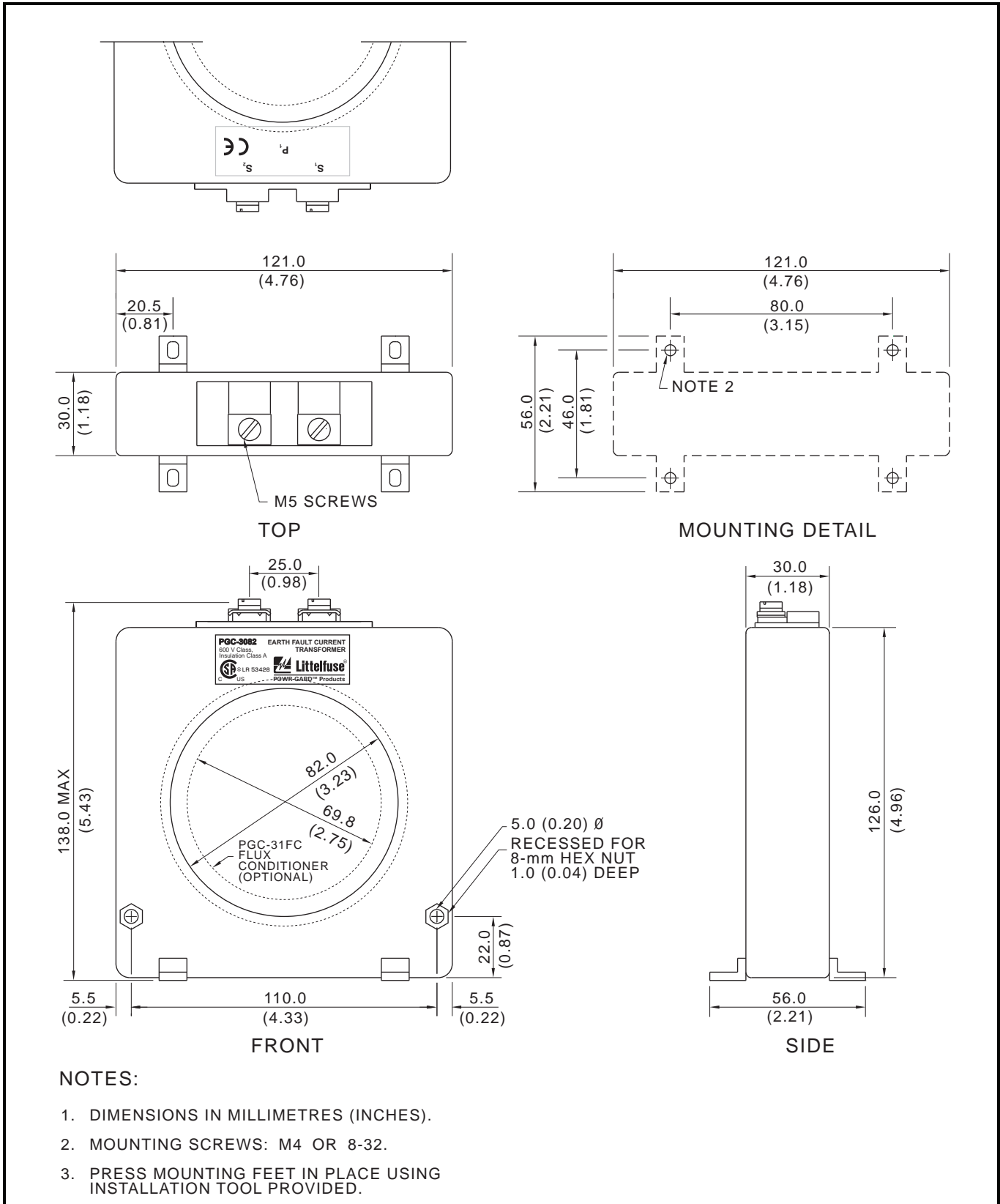

FIGURE 2.5 PGC-3082 Outline and Mounting Details.

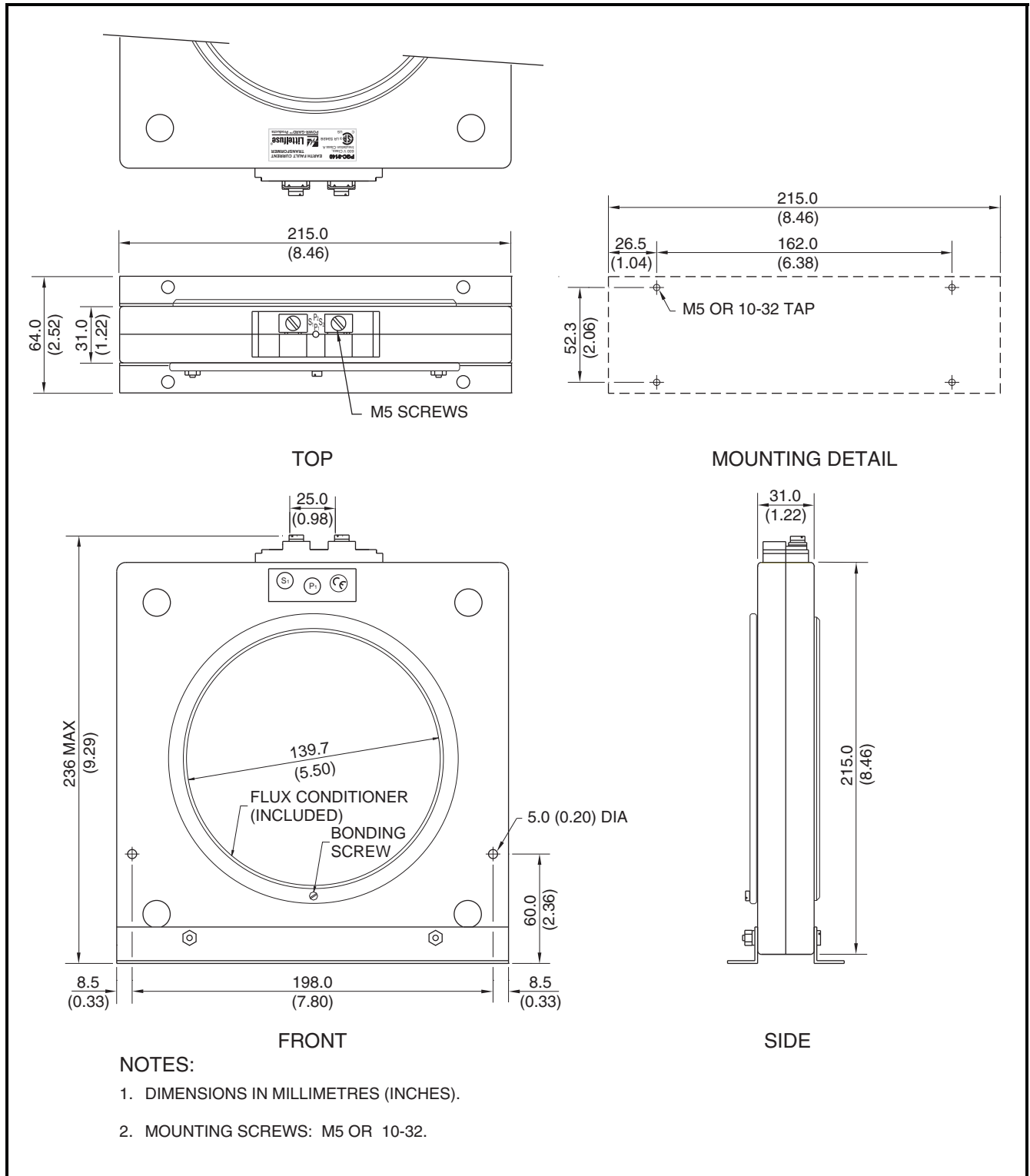

FIGURE 2.6 PGC-3140 Outline and Mounting Details.

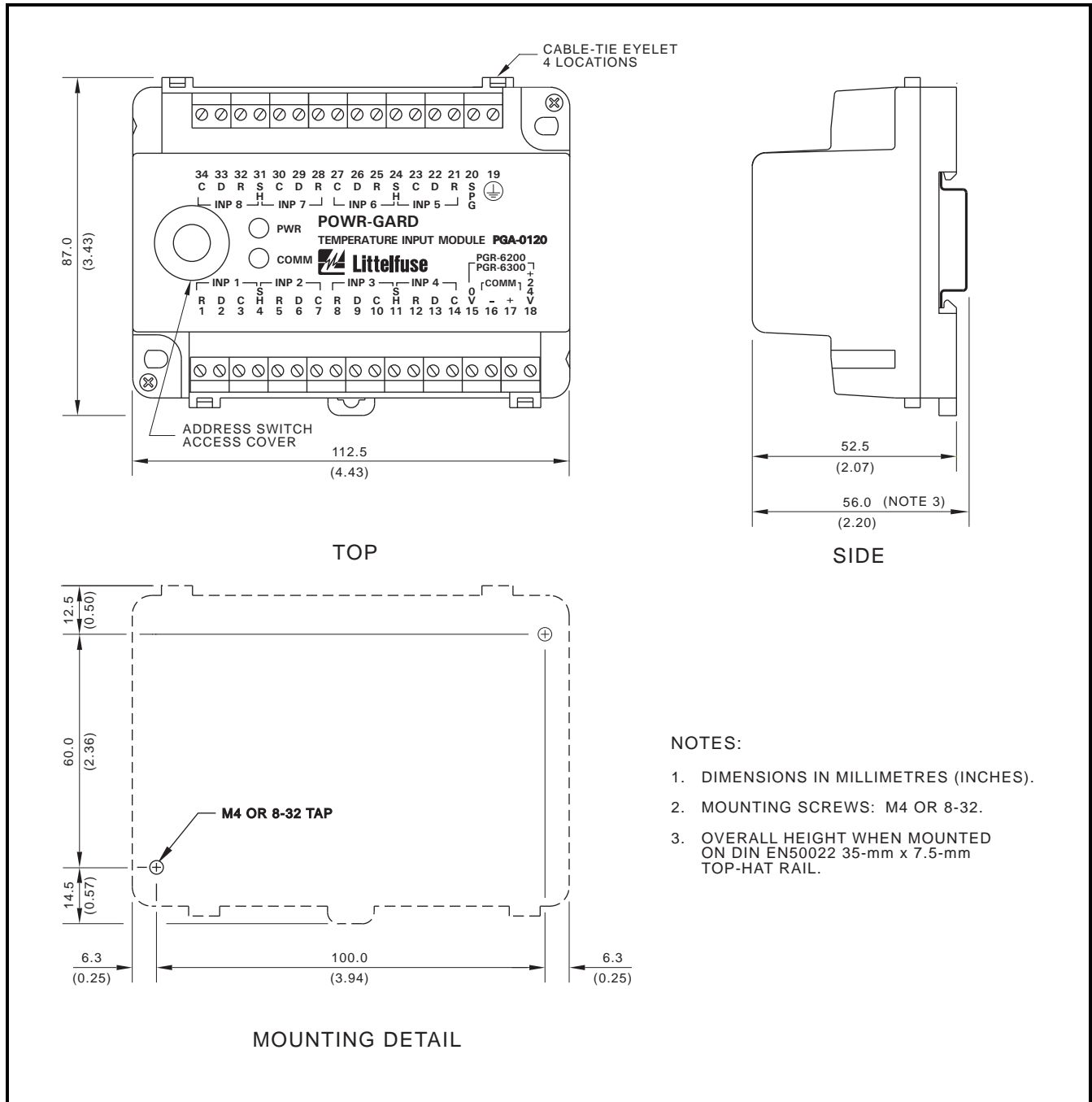

FIGURE 2.7 PGA-0120 Outline and Mounting Details.

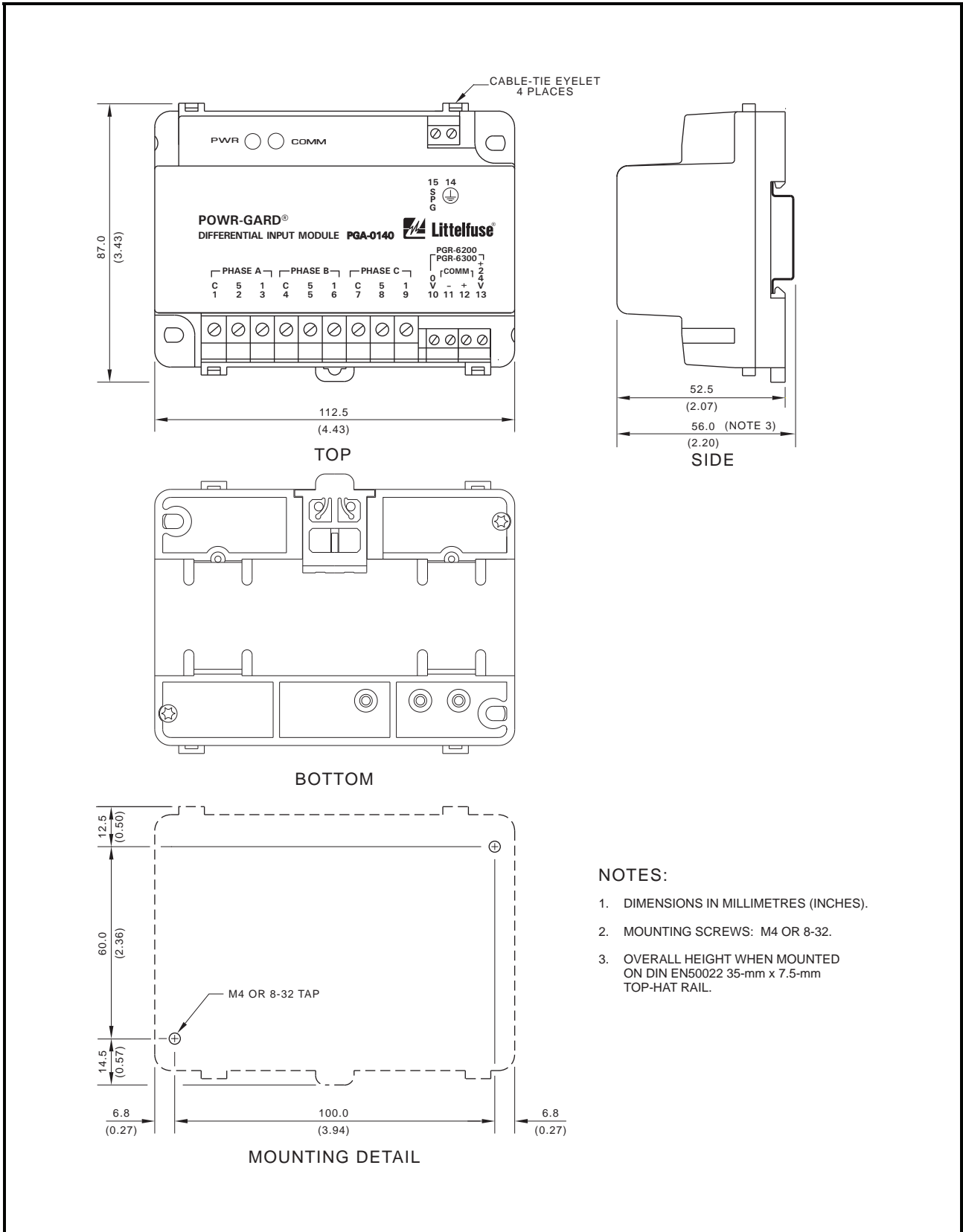

FIGURE 2.8 PGA-0140 Outline and Mounting Details.

This page intentionally left blank.

3. SYSTEM WIRING

3.1 General

A typical connection diagram for a PGR-6200 and PGA-0CIM is shown in Fig. 3.1. See Sections 3.2.3 and 3.2.4 for PGA-0120 and PGA-0140 connections.

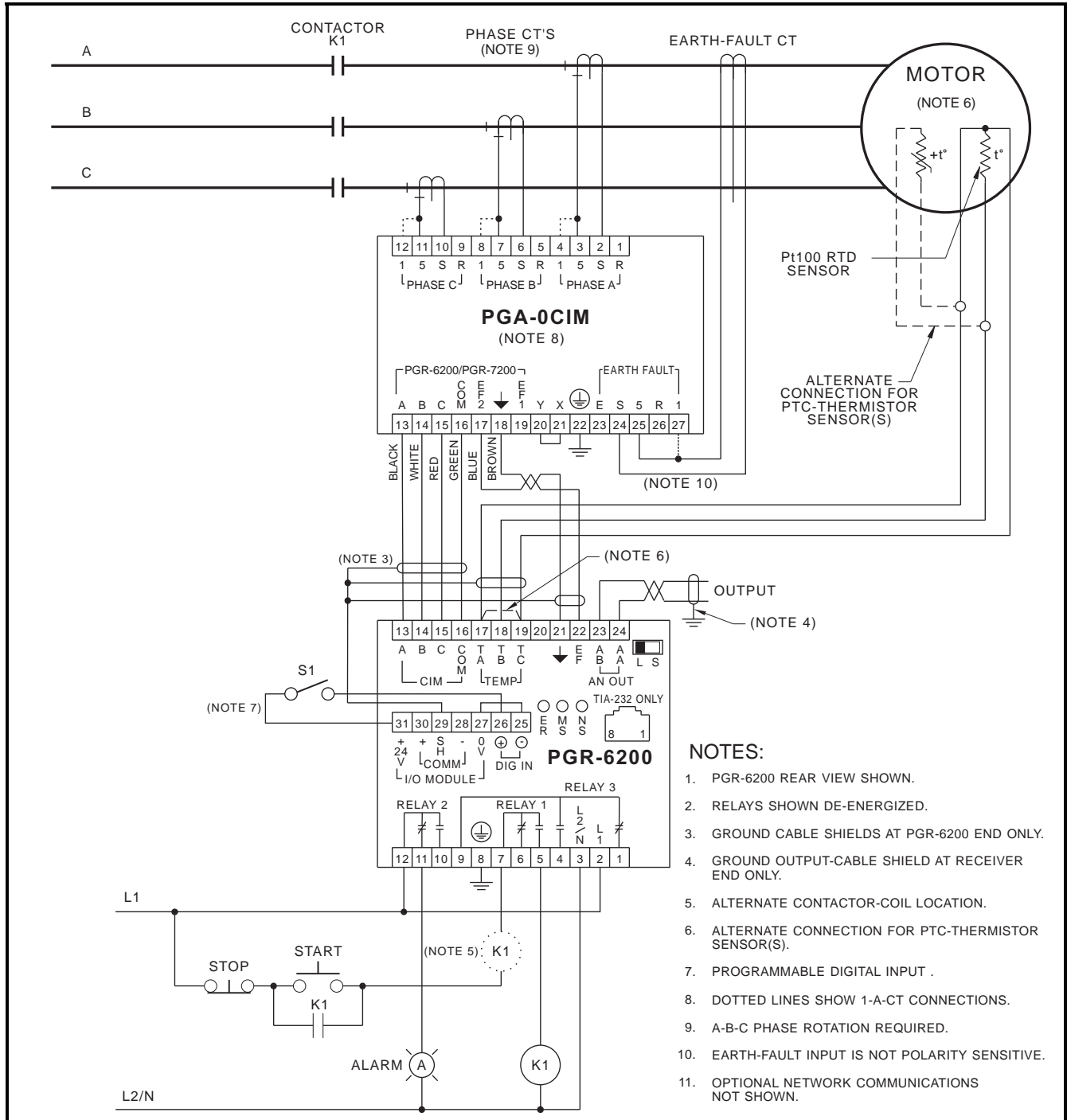

FIGURE 3.1 Typical PGR-6200 Connection Diagram.

3.2 Wiring Connections

3.2.1 PGR-6200 Connections

The PGR-6200 wire-clamping terminal blocks accept 24 to 12 AWG (0.2 to 2.5 mm²) conductors. These terminal blocks unplug to allow the PGR-6200 to be easily removed.

3.2.1.1 Supply Voltage

Derive supply voltage from the line side of the motor controller or from an independent source. Connect supply voltage to terminals 2 and 3 (L1 and L2/N) as shown in Fig. 3.1. In 120-Vac systems, L2/N is designated as the neutral conductor. For direct-current power supplies, use L1 for the positive terminal and L2/N as the negative terminal. Ground terminal 8 (⊕).

3.2.1.2 CIM Input

Connect the PGR-6200 to the PGA-0CIM as shown in Figs. 3.6 and 3.7 using the cable provided.

3.2.1.3 Digital Input

A 24-Vdc digital input is provided on terminals 25 and 26. This input is polarity sensitive. For a logical 1, terminal 26 must be positive with respect to terminal 25. See Section 4.2.5.

The current-limited 24-Vdc source (terminals 27 & 31) can be used to power the digital input.

3.2.1.4 Analog Output

The analog output is switch selectable as self powered or loop powered.

For the self-powered connection, set the L/S switch to the S position. The self-powered connection is shown in Fig. 3.2 (a). The analog output is referenced to the I/O module supply, terminal 27.

For the loop-powered connection, set the L/S switch to the L position. The loop-powered connection is shown in Fig. 3.2 (b). In loop-powered operation, the analog-output is isolated from all other PGR-6200 terminals.

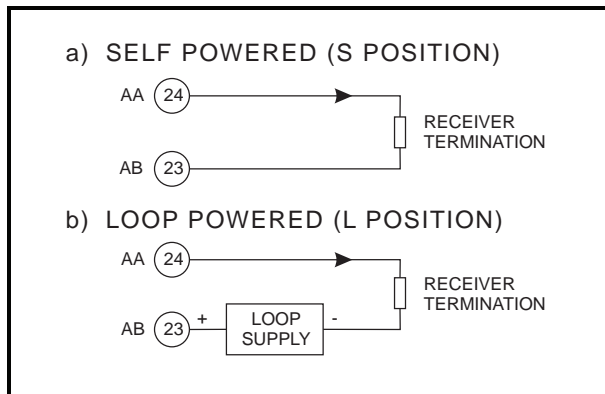

FIGURE 3.2 Analog-Output Connections.

3.2.1.5 PTC or RTD Input (Local)

The temperature-sensor input on the PGR-6200 can be configured for either PTC or Pt100 RTD operation as shown in Fig. 3.3.

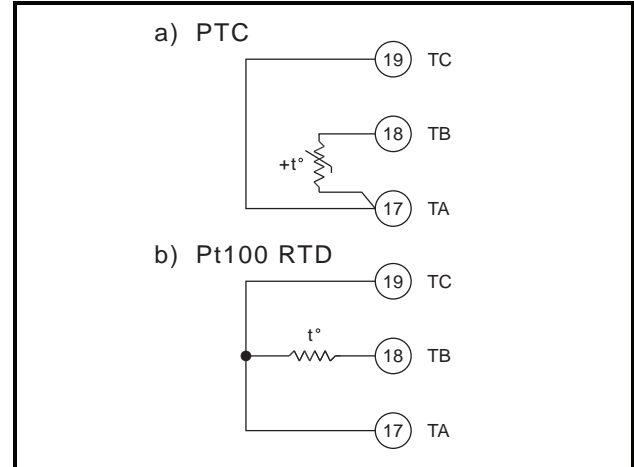

FIGURE 3.3 Local Temperature-Sensor Connections.

3.2.1.6 I/O Module Interface

The I/O module interface supplies power and communications to optional I/O modules such as the PGA-0120 and PGA-0140.

I/O module communication is based on the two-wire multi-drop TIA-485 standard but uses a proprietary protocol. Overall line length must not exceed 1.2 km (4,000'). For line lengths exceeding 10 m (33'), 150-Ω terminations are required at the cable ends. I/O modules are supplied with 4 m (13') of interconnection cable. See Fig. 3.4.

Note: I/O communication is shared with the display. Incorrect wiring can cause the display and keypad to freeze.

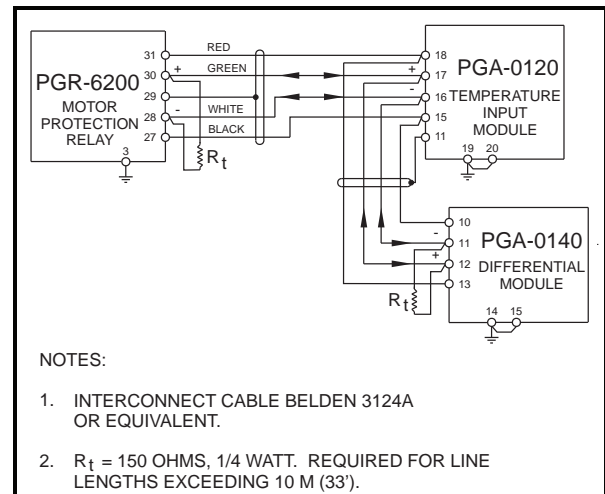

NOTES:

1. INTERCONNECT CABLE BELDEN 3124A OR EQUIVALENT.
2. $R_t = 150$ OHMS, 1/4 WATT. REQUIRED FOR LINE LENGTHS EXCEEDING 10 M (33').

FIGURE 3.4 I/O Module Connection Diagram.

3.2.1.7 RS/EIA/TIA-232 Communications

An RJ-45 TIA-232 connector is provided on the rear panel of the PGR-6200. This port uses Modbus[®] RTU protocol to communicate with PGW-COMM PC-interface software. For Modbus[®] RTU protocol, see Appendix D. The slave ID and communication baud rate are set in the *Setup | Hardware | Local Comms* menu.

Table 3.1 shows the pinout for the optional PGA-0420 adapter for operation with PGW-COMM.

See Fig 3.1 for RJ-45 pinout.

For a USB connection, use an PGA-0440 adapter.

TABLE 3.1 PGA-0420 Adapter Pinout

SYMBOLIC NAME	RJ-45	DB9
RI/DSR	1	9
CD	2	1
DTR	3	4
SG	4	5
RD	5	2
TD	6	3
CTS	7	8
RTS	8	7

3.2.2 PGA-0CIM Connections

The PGA-0CIM CT-input terminal blocks accept 22 to 10 AWG (0.3 to 4.0 mm²) conductors. The remaining PGA-0CIM clamping blocks accept 24 to 12 AWG (0.2 to 2.5 mm²) conductors.

The PGA-0CIM contains four signal-conditioning interface transformers which are interconnected as shown in Fig. 3.5. These transformers isolate the PGR-6200 from the phase and earth-fault CT's. The PGA-0CIM eliminates the need for CT shorting contacts when the PGR-6200 is disconnected. Phase-CT and earth-fault-CT secondaries can be simultaneously grounded through terminal 22 and a jumper to terminal 20. For applications where the CT secondaries must be grounded at another location, the CT secondaries can be isolated by removing shorting screws A, B, and C through holes in the bottom of the PGA-0CIM. See Figs. 2.3 and 3.5.

Note: A-B-C phase sequence and polarity must be observed when connecting phase CT's. See Section 4.2.1.

Connect the PGA-0CIM to the PGR-6200 as shown in Figs. 3.6 and 3.7 using the cable provided.

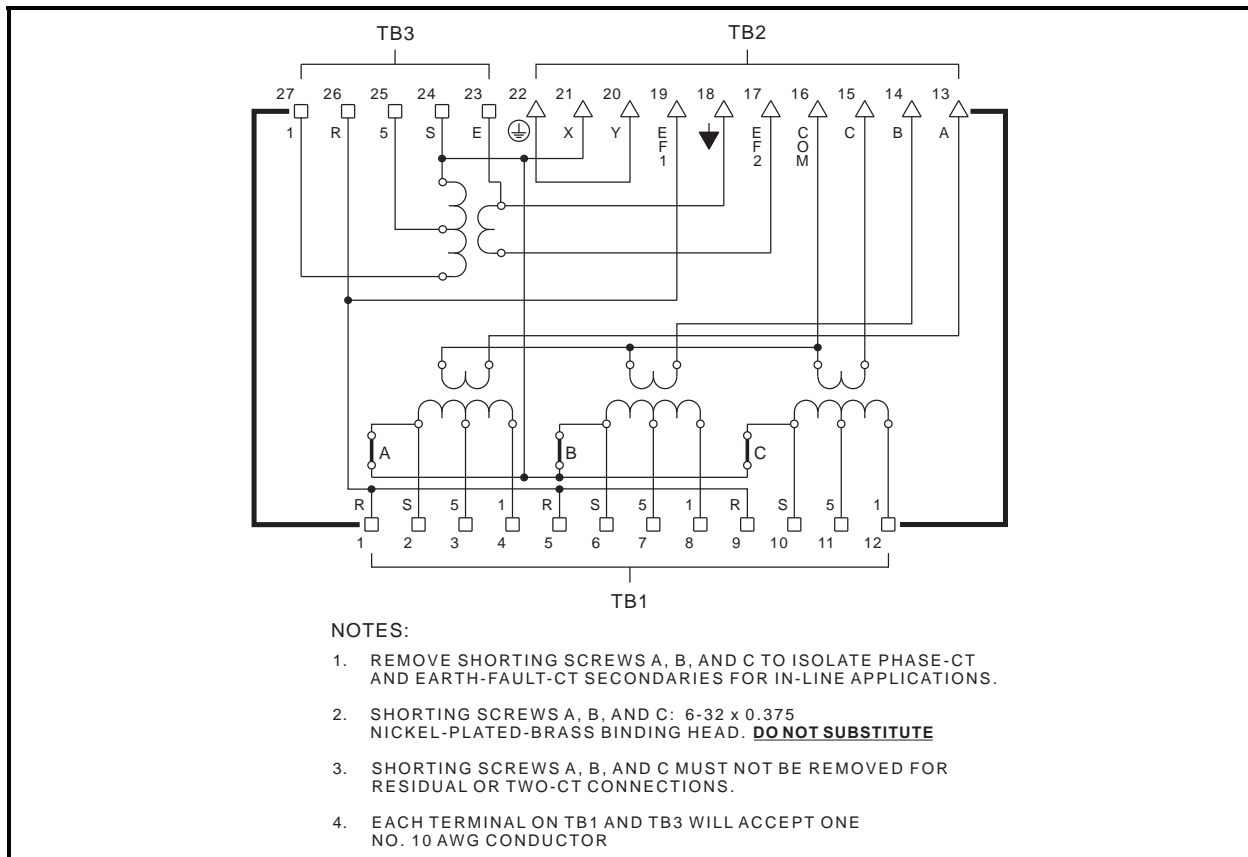

FIGURE 3.5 PGA-0CIM Schematic.

3.2.2.1 Standard

Standard connections with earth-fault CTs are shown in Fig. 3.6. Dotted lines indicate 1-A-CT connections. Use shielded cable for PGC-3000-series current-transformer connections. Ensure only current-carrying phase conductors pass through the earth-fault-CT window and that ground conductors do not.

3.2.2.2 Residual Earth-Fault

The wired residual earth-fault connection is shown in Fig. 3.7 (a). Dotted lines indicate 1-A-CT

connections. Use three identical CT's for this connection.

The PGR-6200 also calculates residual current. See Section 4.2.2.

3.2.2.3 Two-CT

The two-CT connection is shown in Figs. 3.7 (b) and 3.7 (c). Dotted lines indicate 1-A-CT connections. Since this connection derives the current in the unmonitored phase, it should be used only in retrofit applications where it is not possible to install a third CT.

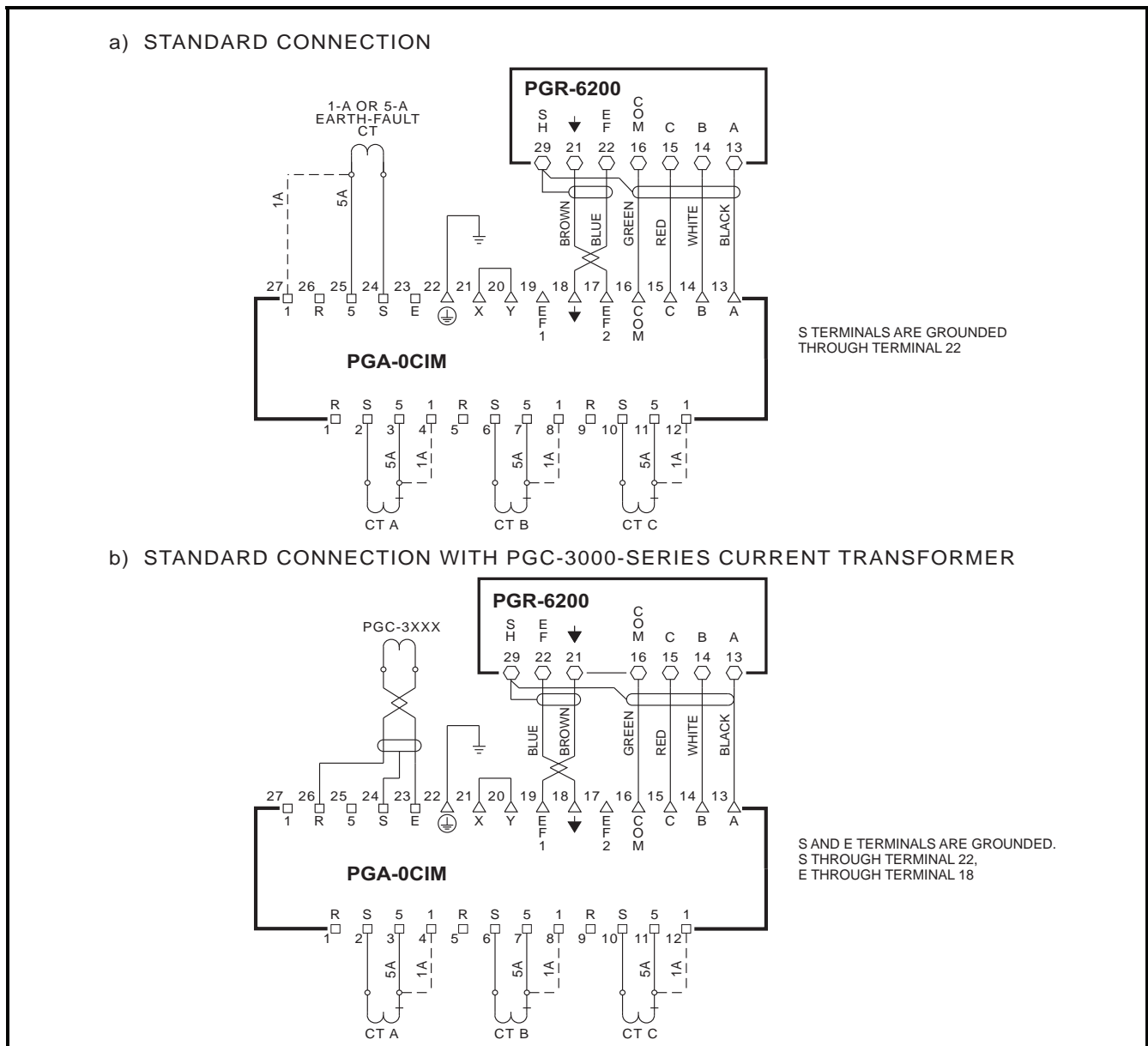

FIGURE 3.6 PGA-0CIM Standard Connections.

3.2.3 PGA-0120 Connections and Address Selection

Connect the PGA-0120 Temperature Input Module to the PGR-6200 using the four-conductor shielded cable (Belden 3124A or equivalent) supplied with the PGA-0120 as shown in Fig. 3.8. The PGR-6200 24-Vdc supply can power up to three PGA-0120 modules.

Connect RTD's to the PGA-0120 as shown in Fig 3.8. When the RTD module is installed in a motor junction box, RTD-lead shielding is not required. PGA-0120 terminal blocks accept 24 to 12 AWG (0.2 to 2.5 mm²) conductors.

Connect surge-protection (SPG) terminal 20 to terminal 19 (⊕) and ground terminal 19.

The PGA-0120 has two switches to select its network address. See Fig. 3.8. Up to three PGA-0120 modules can be connected to the I/O MODULE bus, and each RTD-module address must be unique. If one module is used, address 1 must be used. If two RTD Modules are used, addresses 1 and 2 must be used. If three RTD Modules are used, addresses 1, 2, and 3 must be used.

Table 3.2 shows the address selection format.

TABLE 3.2 PGA-0120 Address Selection

ADDRESS	SWITCH 1	SWITCH 2
0 (Off line)	Open	Open
1 (First RTD module)	Closed	Open
2 (Second RTD module)	Open	Closed
3 (Third RTD module)	Closed	Closed

3.2.4 PGA-0140 Connections

Connect the PGA-0140 Differential Input Module to the PGR-6200 using four-conductor shielded cable (Belden 3124A or equivalent) as shown in Fig. 3.4.

Connect the surge-protection (SPG) terminal 15 to terminal 14 (⊕), and ground terminal 14.

The PGA-0140 CT-input terminal blocks accept 22 to 10 AWG (0.3 to 4.0 mm²) conductors. The remaining PGA-0140 clamping blocks accept 24 to 12 AWG (0.2 to 2.5 mm²) conductors.

3.2.4.1 Core Balance

The core-balance connection uses three differential CT's as shown in Fig. 3.9. To minimize power-cable and CT secondary lead lengths, both the differential CT's and the PGA-0140 can be located near the motor. The primary rating of the differential CT does not have to match the phase-CT primary rating and is usually selected with a lower ratio resulting in more sensitive differential protection. The core-balance method avoids CT-matching issues and is the preferred connection.

3.2.4.2 PGR-6200 Summation

The PGR-6200-summation connection uses three phase CT's and three differential CT's as shown in Fig. 3.10. Both CT-ratio and CT-saturation characteristics must be matched to avoid differential currents under motor starting and running conditions. The PGA-0140 module should be located near the PGA-0CIM to minimize CT-wire length. It is preferred to use three dedicated phase CT's and three core-balance differential CT's as described in Section 3.2.4.1.

For the delta connection, the *FLA Rating* is set equal to the motor's full-load current multiplied by $\sqrt{3}$.

3.2.4.3 DIF Summation

The DIF-summation connection uses six differential CT's as shown in Fig. 3.11. Both CT-ratio and CT-saturation characteristics must be matched to avoid differential currents under motor starting and running conditions. It is preferred to use three core-balance CT's as described in Section 3.2.4.1. This six-CT connection allows the CT's and PGA-0140 to be placed near the motor to minimize power-cable and CT-lead length.

3.2.5 Cable Restraint

All conductors should be restrained within 100 mm (4") of the terminal blocks. Four cabling-restraint points are provided on the PGR-6200 rear panel. Secure cables to the PGA-0CIM, PGA-0120 and PGA-0140 using the cable-tie eyelets and the cable ties provided. See Figs. 2.1, 2.3, 2.7 and 2.8.

3.2.6 Dielectric-Strength Testing

Dielectric-strength testing can be performed only on CT inputs, supply-voltage input, and output relays. Unplug all other I/O and remove the PGA-0CIM (⊕) connection (terminal 22) during dielectric-strength testing.

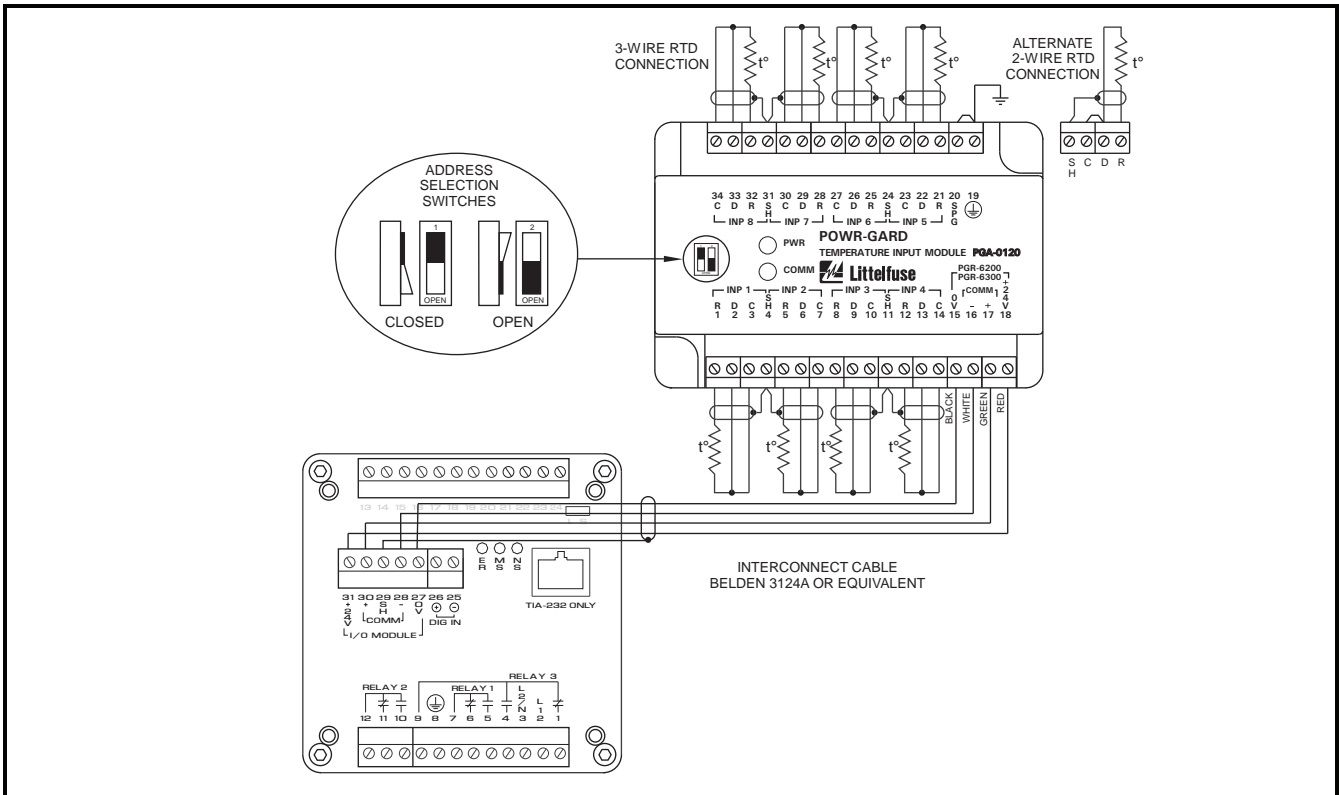

FIGURE 3.8 PGA-0120 Connection Diagram.

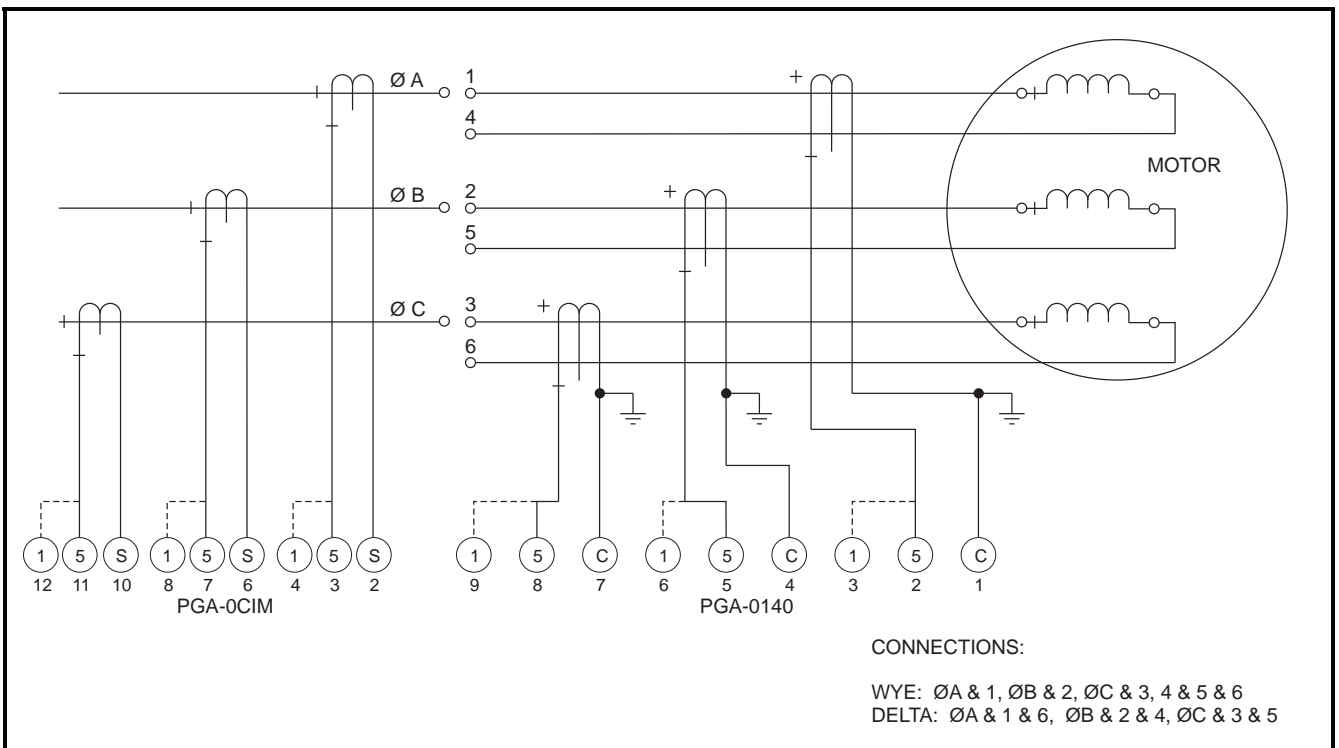

FIGURE 3.9 Core-Balance Connection.

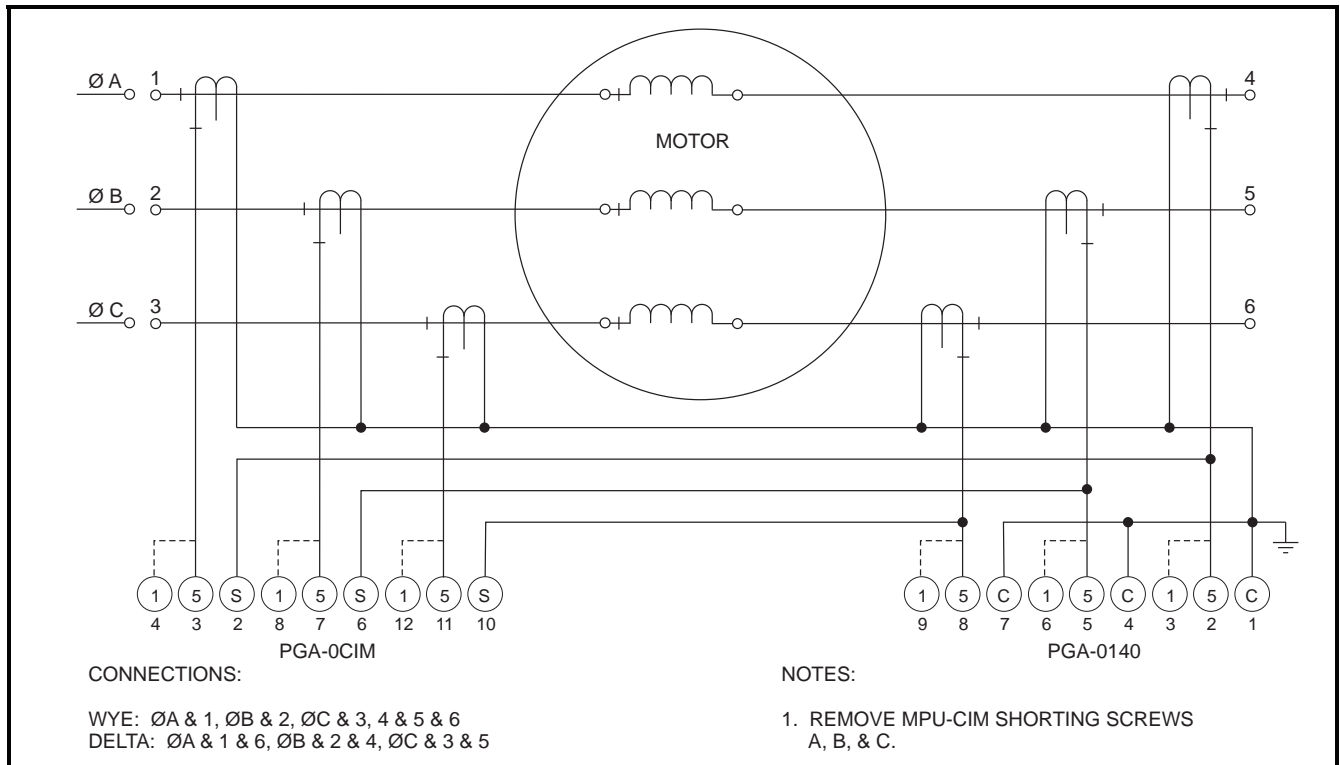

FIGURE 3.10 PGR-6200-Summation Connection.

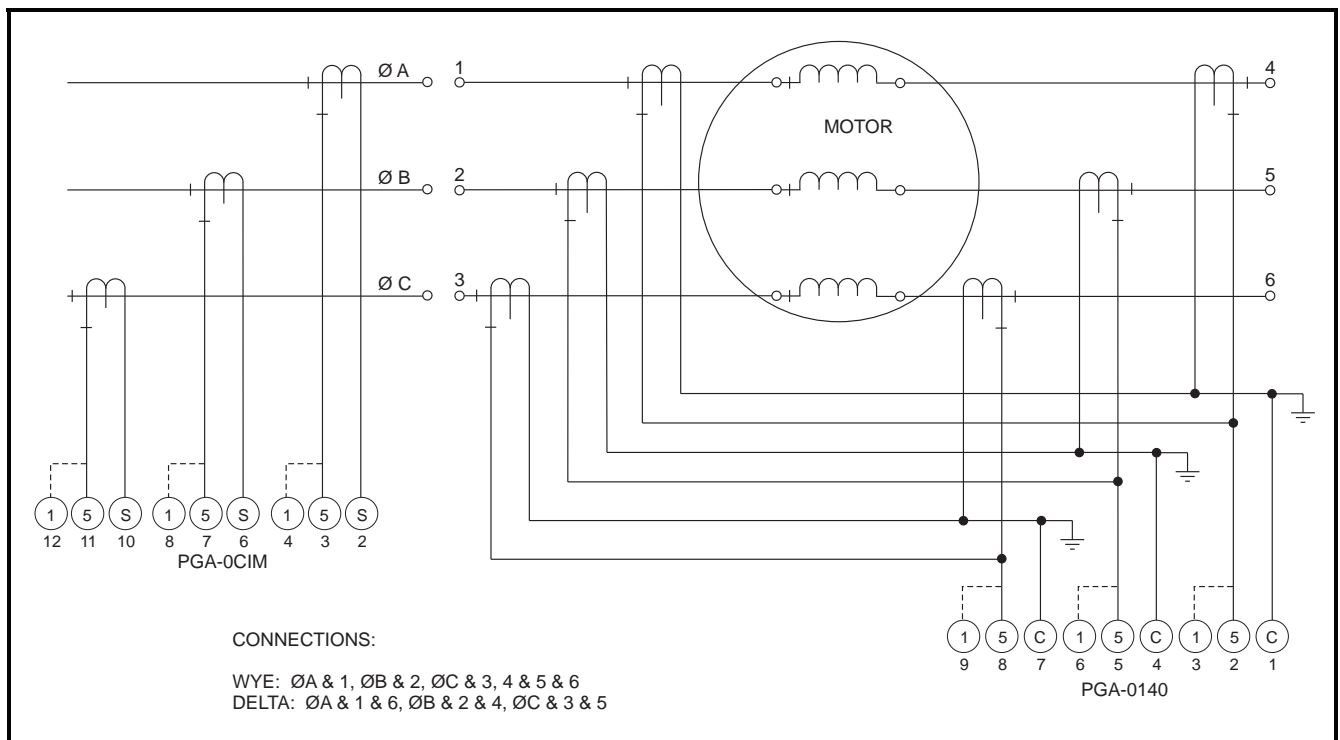

FIGURE 3.11 DIF-Summation Connection.

4. OPERATION AND SETUP

4.1 Display and Indication

All PGR-6200 information displays and settings can be accessed using the PGR-6200 menu system, the TIA-232 interface, or a network-communications interface.

In the following sections, menu items and setup parameters are listed in italics and are shown in the format displayed on the alphanumeric LCD. The LCD cannot display subscripts and superscripts.

Menu selection is in the following format:

Menu 1 | Sub Menu 1 | Sub Menu 2 | Sub Menu 3 |.....

Example: For the menu item shown in Fig. 4.1, the notation is *Setup | System Ratings | CT Primary*

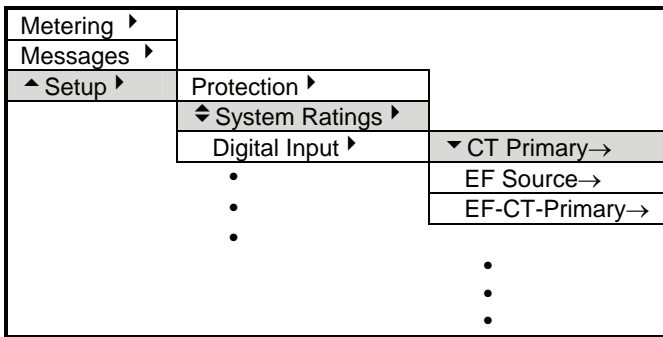

FIGURE 4.1 Menu Example.

Fig. 4.2 shows the symbols that assist in navigating the menu system and how these symbols relate to the arrow keys on the PGR-6200. See the PGR-6200 menu map in Appendix A.

4.1.1 Front-Panel LED Indication

Menu: *Setup | System Config | UPI LED*

The red TRIP and yellow ALARM LED's indicate a trip or alarm condition. The green RUN LED is OFF when current is not detected, flashes when the motor is starting, and is ON when the motor is running. The yellow UPI LED is a user-programmable indicator and its function is defined by one of the menu selections shown in Table 4.1.

TABLE 4.1 UPI LED Functions

SELECTION	DEFINITION
None	LED remains off.
Trip1	Trip1 condition exists.
Trip2	Trip2 condition exists.
Trip3	Trip3 condition exists.
Alarm1	Alarm1 condition exists.
Alarm2	Alarm2 condition exists.
Alarm3	Alarm3 condition exists.
Relay1	Relay1 is energized.
Relay2	Relay2 is energized.
Relay3	Relay3 is energized.
Digital Input	Digital Input is valid.
Current Detected	Current is above minimum threshold.
Current > 125%	Current is above 125% FLA.
Run Mode	PGR-6200 is in Run mode.
ETR	PGR-6200 is in Emergency Thermal Reset state
Start Inhibit	In I ² t or starts-per-hour inhibit state.
Network Run1	Run1 is issued by a network command.
Net Activity	Activity is detected on the communications interface.
Reduced OC	Reduced Overcurrent protection is active.

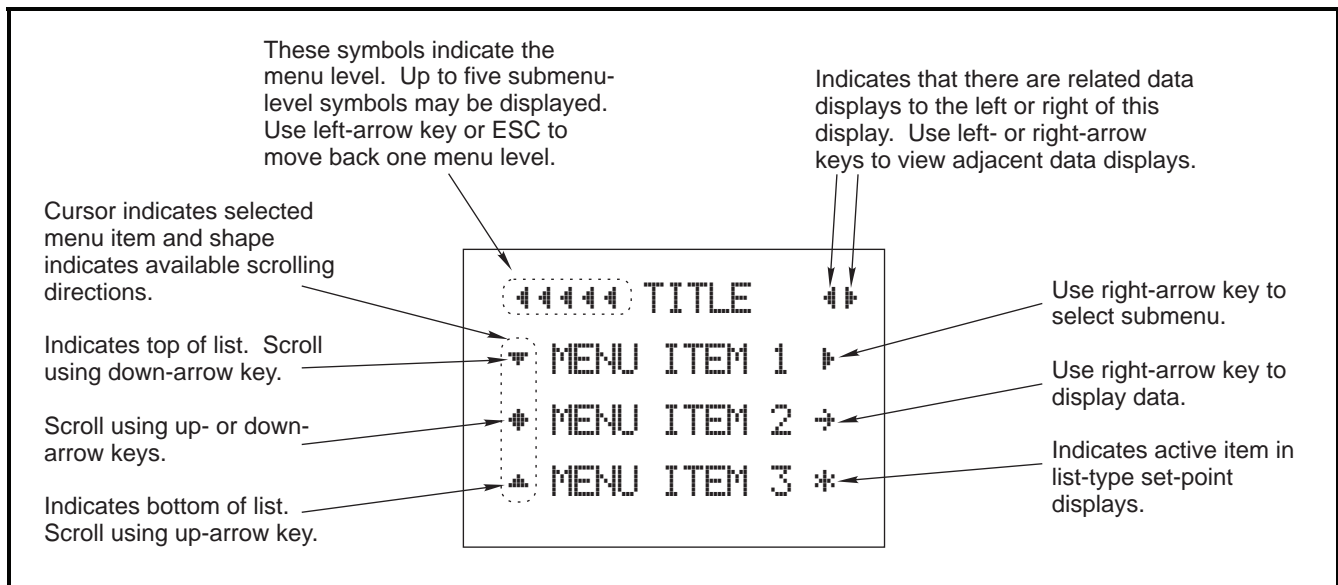

FIGURE 4.2 Menu Symbols.

4.1.2 Rear-Panel LED Indication

The three LED's on the rear panel are labeled ER, MS, and NS. The red ER (Error) LED is OFF during normal operation and is ON when there is a processor error or during firmware-update operation. Output relays are de-energized when this LED is ON. The MS (Module Status) and NS (Network Status) LED's are used for network-communications and firmware-update annunciation. The specific colour and function of these LED's is defined by the network-communications option installed in the PGR-6200. For detailed information, see the applicable communications manual.

4.1.3 Display Contrast and Test

Contrast control and test operator-interface features are available when the display is in Local mode. To prevent a *Display Comm Trip*, select *Disabled* in the *Setup | Hardware | OPI Display | Trip Action* menu. To enter Local mode, press the up-arrow, right-arrow, and ENTER keys simultaneously.

In Local mode, all face-plate LED's are ON and the display indicates three menu items; *Contrast*, *Address*, and *Enter Test Mode*. Use the up- and down-arrow keys to select the menu item.

Contrast: Use the right- and left-arrow keys to increase or decrease contrast.

Address: The display address indicates 1 and cannot be changed.

Enter Test Mode: Press the right-arrow key to enter test mode. In test mode, the LED test, Display test, and Display-Heater test are automatically performed. The Interactive-Key test is then entered and the following symbols are displayed when a key is pressed.

Left Key:	⏪
Right Key	⏩
Up Key	⏴
Down Key	⏵
ESC:	^
ENTER:	↵
RESET:	Press RESET to exit this menu.

Press the ESC key to exit Local mode and return to the PGR-6200 menu. Re-enable *OPI Display Trip Action*.

4.2 Setup

Certain PGR-6200 settings cannot be changed when the motor is running. See Appendix B.

4.2.1 Phase-CT Inputs

Menu: *Setup | System Ratings | CT Primary*

The CT-primary setting range is 1 to 5,000 A. To maintain specified accuracy, phase CT's should be selected with a primary rating between 100 and 300% of motor full-load current.

For A-B-C sequence, the +Seq I_1 display value is larger than the -Seq I_2 display value and positive current unbalance is indicated. Negative current unbalance will be indicated if the phase sequence is B-A-C. If negative unbalance is indicated, correct the phase-CT connections. Severe current unbalance may be indicated when phase-CT polarity is incorrect.

4.2.2 Earth-Fault-CT Input

Menu: *Setup | System Ratings | EF Source*

Menu: *Setup | System Ratings | EF-CT Primary*

The *EF Source* menu selects the earth-fault source as *Calculated ($3I_0$)* or *Measured (I_{ct})*.

The *Calculated ($3I_0$)* selection uses the $3I_0$ value obtained from the sequence-component calculation and is based on the phase currents only. Set the *EF-CT Primary* to the phase-CT-primary rating when *Calculated ($3I_0$)* is selected.

The *Measured (I_{ct})* selection uses current measured by an earth-fault CT or the residual connection. Set *EF-CT Primary* to the earth-fault-CT-primary rating when an earth-fault CT is used. For the sensitive PGC-3082 and PGC-3140 earth-fault CT's, set *EF-CT Primary* to 5 A. Set *EF-CT Primary* to the phase-CT-primary rating for the residual-CT connection.

The setting range for the *EF-CT-Primary* rating is 1 to 5,000 A.

Note: Calculated $3I_0$ does not detect CT saturation. Enable overcurrent protection when earth-fault current can exceed 15 times the phase-CT primary rating.

Note: $3I_0$ and I_{ct} values will be shown in the *Metering | Earth Leakage* display regardless of the *EF Source* selection or CT connections.

Note: For the residual connection and *Calculated ($3I_0$)* selection, the earth-fault-trip setting should be greater than 5%.

4.2.3 Motor Data

Menu: *Setup | System Ratings*

Menu: *Setup | Protection | Overload*

In the *System Ratings* menu, motor data must be entered for the *FLA Rating* (full-load current), *Frequency*, and *Service Factor*.

Set *Frequency* at 50 Hz, 60 Hz, or *Variable*. Use *Variable* for adjustable-speed drive applications.

LR Current (locked-rotor current), *LR Time Cold* (cold locked-rotor time), and *LR Time Hot* (hot locked-rotor time) must be entered in the *Setup | Protection | Overload* menu to provide customized overload protection. See Section 5.2.

4.2.4 Output Relay Assignment

Menu: *Setup* | *Relay Outputs* | *Relay x*
 Menu: *Setup* | *Relay Outputs* | *RY Pulse Time*

Each of the three output relays can be assigned to one of the functions listed in Table 4.2. More than one relay can be assigned the same function. Trip and alarm assignments operate in the selected fail-safe or non-fail-safe mode.

The default assignment for Relay 1 is Trip1, for Relay 2 is Alarm1, and for Relay 3 is None. The default mode setting for all three relays is Fail-Safe.

4.2.5 Digital Input

Menu: *Setup* | *Digital Input* | *Input Function*
 Menu: *Setup* | *Digital Input* | *Start Bypass*
 Menu: *Setup* | *Digital Input* | *Bypass Delay*
 Menu: *Setup* | *Digital Input* | *Trip Delay*

The digital input can be assigned to one of the functions listed in Table 4.3.

When the digital input is assigned the *Trip1* function, *Start Bypass*, *Bypass Delay*, and *Trip Delay* set points become active. When *Start Bypass* is enabled, the digital input is bypassed during a start for the duration specified by *Bypass Delay*. Start detection is based on motor current. After the *Bypass Delay*, the digital input is enabled and a trip occurs if the digital-input voltage is removed for the time specified by the *Trip Delay*. If *Start Bypass* is disabled, *Bypass Delay* is not used and the digital input *Trip1* function is always

enabled. The bypass feature can be used in pump-control applications to allow time for a pressure switch to close.

When the digital input is assigned to *Reset*, trips can be reset using an external reset switch. The *Reset* input is a “one-shot” reset and requires a transition from open to closed. Maintaining a reset switch closure does not inhibit trips.

When assigned to *Program Enable*, password protection is disabled and program access is a function of the digital-input state as defined in Table 4.3.

TABLE 4.3 Digital-Input Functions

FUNCTION	STATE ⁽¹⁾
Trip1	1 = No Trip1 0 = Trip1 (Delay selectable, reset required)
Reset	1 = Reset Trips
Program Enable ⁽²⁾	1 = Program changes allowed 0 = Program changes not allowed
Reduced OC	1 = Reduced Overcurrent set point not operational (ROC = Off) 0 = Reduced Overcurrent set point operational (ROC = On)
None	No assignment (Default)

⁽¹⁾ 1 = 24 Vdc applied, 0 = 24 Vdc not applied

⁽²⁾ Password is disabled.

TABLE 4.2 Output-Relay Functions

FUNCTION	ASSIGNMENT OR ACTION
Trip1	Relay operates when a trip occurs in a protective function assigned Trip1, Trip1&2, Trip1&3, or Trip1,2&3 trip action. Fail-safe or non-fail-safe mode selection is active.
Trip2	Relay operates when a trip occurs in a protective function assigned Trip2, Trip1&2, Trip2&3, or Trip1,2&3 trip action. Fail-safe or non-fail-safe mode selection is active.
Trip3	Relay operates when a trip occurs in a protective function assigned Trip3, Trip1&3, Trip2&3, or Trip1,2&3 trip action. Fail-safe or non-fail-safe mode selection is active.
Alarm1	Relay operates when an alarm occurs in a protective function assigned Alarm1, Alarm1&2, Alarm1&3, or Alarm1,2&3 alarm action. Fail-safe or non-fail-safe mode selection is active.
Alarm2	Relay operates when an alarm occurs in a protective function assigned Alarm2, Alarm1&2, Alarm2&3, or Alarm1,2&3 alarm action. Fail-safe or non-fail-safe mode selection is active.
Alarm3	Relay operates when an alarm occurs in a protective function assigned Alarm3, Alarm1&3, Alarm2&3, or Alarm1,2&3 alarm action. Fail-safe or non-fail-safe mode selection is active.
Current	Relay is energized when current is detected.
Run Mode	Relay is energized when in run mode. (Current <125% FLA for <i>Run-Mode Delay</i>).
Start Inhibit	Relay is energized when in an I ² t or starts-per-hour inhibit condition.
Trip 1 Pulse ⁽¹⁾	Trip 1 energizes relay for the time duration specified by the <i>RY Pulse Time</i> set point.
Run1	Relay is energized by a network “Run1 Set” command and de-energized by a “Run1 Clear” command.
Watchdog	Relay is energized when the PGR-6200 is operating properly.
Reduced OC	Relay is energized when in reduced overcurrent mode (ROC = On)
None	No Assignment

⁽¹⁾ Assign this function to only one relay. Non-fail-safe operation only.

The *Reduced OC* selection operates in conjunction with the reduced-overcurrent set point which must be enabled. See Section 5.5.

When *Reduced OC* is selected and no digital-input voltage is applied, the reduced-overcurrent set point is operational. When digital-input voltage is applied, the reduced-overcurrent set point is not operational

4.2.6 Analog Output

Menu: *Setup | Analog Output*

The 20-mA analog output can be programmed for one of the parameters shown in Table 4.4.

The analog output is factory calibrated for zero equals 4.0 mA and full scale equals 20.0 mA.

If adjustment is required, use the *Analog Output* menus.

Zero Calibration:

- Select *Zero* in the *Output Parameter* menu.
- Measure the output current and adjust the *Zero Calibrate* setting for the desired output. The calibration number for 4 mA will be in the range of 100 to 110.

Full-Scale Calibration:

- Select *Full Scale* in the *Output Parameter* menu.
- Measure the output current and adjust the *FS Calibrate* setting for the desired output. The calibration number for 20 mA will be in the range of 540 to 550.

Calibration numbers are not changed when factory defaults are loaded, or during a firmware update.

4.2.7 Miscellaneous Configuration

Menu: *Setup | System Config*

<i>System Name</i>	Appears on many of the display screens and can be set by the user (18-character alphanumeric field).
<i>Password</i>	Used to change the 4-character alphanumeric password.
<i>Clock Setting</i>	Used to set the date and 24-hour clock.
<i>Password Timeout</i>	Used to set the password time-out delay. Delay is measured from last key press.
<i>Run Mode Delay</i>	Run mode is entered when current is between 5 and 125% FLA for the specified time.
<i>UPI LED</i>	Used to assign an internal parameter to the UPI LED.
<i>Maintenance</i>	Used to clear event records, trip counters, and run hours. Used to load defaults. Used to view firmware version, unit serial number, and MAC address. Used for firmware updates.

4.2.8 Communications

Menu: *Setup | Hardware*

The TIA-232 interface uses the Modbus® RTU protocol. Set the ID and baud rate to match the requirements of the communications device. Default settings are the same as PGW-COMM PC-interface software defaults.

If equipped with an optional network-communications interface, refer to the appropriate communications-interface manual.

Note: RS-232, EIA-232 and TIA-232 signal specifications are compatible with the PGR-6200.

TABLE 4.4 Analog-Output Parameters

PARAMETER	DESCRIPTION	FULL SCALE
Phase Current	Maximum of the three phase currents.	Phase-CT-primary rating
EF (I _{ct} Measured)	Measured earth-leakage current from EF-CT.	Earth-fault-CT-primary rating
EF (3I ₀ Calculated)	Calculated earth-leakage current from phase CT's.	Phase-CT-primary rating
Used I ² t	Used thermal capacity.	100% I ² t
Local RTD	Local RTD temperature. ⁽¹⁾	200°C
Mod Stator RTD	Temp. module maximum stator temperature. ^(1,2)	200°C
Mod Bearing RTD	Temp. module maximum bearing temperature. ^(1,2)	200°C
Mod Load RTD	Temp. module maximum load temperature. ^(1,2)	200°C
Mod Ambient RTD	Temp. module maximum ambient temperature. ^(1,2)	200°C
Unbalance	Current unbalance (I ₂ /I ₁).	1 per unit or 100%
Zero	Zero calibration.	Not applicable
Full Scale	Full-scale calibration.	Not applicable
Differential	Maximum phase-differential current	Differential-CT-primary rating

⁽¹⁾ The output defaults to the calibrated zero output for an open or shorted RTD sensor.

⁽²⁾ Requires optional PGA-0120 Temperature Input Module.

4.3 Metering

Menu: *Metering*

When *Metering* is selected in the main menu, press the right-arrow key to access a list of metering displays. Use the up- and down-arrow keys to scroll through the display list. Pressing the right-arrow key displays the selected metering information.

RESET is a "hot key" that is active in all meter displays. Pressing RESET causes a jump to the *Trip and Alarm* display to allow trips to be viewed and reset. Pressing ESC or the left-arrow key causes a return to the *Metering* display.

Many displays include per unit (pu) values where 1.0 pu is equal to 100%. I_a , I_b , I_c , I_1 , and I_2 are in per unit of full-load current. $3I_0$ is in per unit of phase-CT-primary rating and I_{ct} is in per unit of earth-fault-CT-primary rating.

The unbalance display indicates minus (-) if current inputs are not sequenced A-B-C.

Table 4.5 shows the information that can be displayed in each metering display.

4.4 Messages

Menu: *Messages*

Selecting *Messages* allows trip, alarm, and inhibit messages, event records, and statistical data to be viewed and resets to be performed.

4.4.1 Trip Reset

Menu: *Messages | Trip and Alarm*

Up to fifteen trip and alarm messages can be displayed in a scrollable-list format. Trips must be individually selected and reset if the RESET key is used. All trips are simultaneously reset by a digital-input reset or with a communications-network command. Alarms are non-latching and are displayed only for the time that the alarm condition exists.

RESET is a "hot key" to the *Trip and Alarm* display, except during set-point entry. In the *Trip and Alarm* display, pressing ESC or the left-arrow key causes a return to the display shown when RESET was pressed.

TABLE 4.5 Metering Display

METERING MENU	INFORMATION DISPLAY ⁽¹⁾
Current	I_a , I_b , I_c in A and per unit of I_p
Unbalance	I_1 , I_2 , in per unit of I_p , I_2/I_1 in per unit
Earth Leakage	I_{ct} in A and per unit of I_p , $3I_0$ in A and per unit of I_e . Displays which earth-leakage-protection input is active.
Thermal Capacity	Used I^2t in percent Trend I^2t in percent Displays reset time when tripped on I^2t . Displays time to trip if in overload. Displays time to I^2t Inhibit removal. Displays time to Starts-Per-Hour Inhibit removal. Displays number of available starts.
Differential	DIF_a , DIF_b , DIF_c in A and per unit of I_d .
Temperature Input Module Temperatures	Summary shows maximum and minimum temperatures for stator, bearing, and load RTD's in °C. Module and input numbers, name, function, temperature in °C for each enabled RTD
Local Sensor	Sensor Type: RTD or PTC. Displays temperature in °C when type is RTD. Displays Open or Short RTD failure. Displays sensor status (Normal, Open, Short) when type is PTC.
I/O Status	Digital input On or Off and relay outputs in binary.
System Status	Date and time, motor mode (Stopped, Start, Run). Displays Reduced Overcurrent mode (ROC: On, ROC: Off). Displays ETR mode.
Network Status	Displays Modbus state as online or timed out. Displays DeviceNet errors and status.

⁽¹⁾ All but Temperature Module metering displays show System Name.

4.4.2 Data Logging

Menu: *Messages | Event Records*

Trip-record data, start-record data, and Emergency Thermal Resets (ETR) are logged. Trip-record data includes the time of trip, cause of trip, and pre-trip data. ETR records contain a snapshot of the data prior to an ETR.

Trip- or ETR-records data include:

- Time StampYY/MM/DD HH:MM:SS,
- I_a , I_b , I_c , and I_g ⁽¹⁾ at time of trip or ETR,
- Differential currents at time of trip or ETR,
- Unbalance (I_2/I_1) at time of trip or ETR,
- I^2t at time of trip or ETR, and
- PTC/RTD temperature data if applicable.

Start records⁽²⁾ are triggered by motor current and include:

- Time Stamp YY/MM/DD HH:MM:SS,
- maximum values of I_a , I_b , I_c , and I_g ⁽¹⁾ during the start,
- maximum value of I_2/I_1 during the start,
- maximum values of differential currents during the start,
- I^2t used during the start⁽³⁾,
- start duration, and
- PTC/RTD temperature data if applicable.

Each record includes a record number in the first line of the record-data display. The record number is incremented when a new record is generated and has a range from 0 to 65535. When the *Event Record* menu is entered, the first record displayed is the latest record. The right-arrow key scrolls through previous records. Record scrolling stops when the 100th record has been reached or an empty record is displayed.

Event records can be cleared in the *Setup | System Config | Maintenance* menu.

Record TypeTrip/ETR/Start
 Number of Records100 (First In First Out)

- (1) I_g is calculated from phase-current data, when *EF Source* is set to *Calculated (3I₀)* and is the measured EF-CT current when *EF Source* is set to *Measured (I_{ct})*.
- (2) Values updated at 0.5-s intervals during a start and stored when the Run mode is entered.
- (3) Starting I^2t can be used to determine the *I²t Inhibit Level*. See Section 5.2.

4.4.3 Statistical Data

Menu: *Messages | Statistics*

The PGR-6200 records the following statistical data:

- Running hours,
- Counters for each trip type.

Statistical data can be cleared in the *Setup | System Config | Maintenance* menu.

4.4.4 Emergency Thermal Reset

Menu: *Messages | Emerg I²t Reset*

The *Emerg I²t Reset* menu is used to set *Used I²t* to zero. See Section 5.2.3.

4.5 Password Entry and Programming

Menu: *Setup | System Config | Password Timeout*

Note: The default password is 1111. When the digital input is programmed for Program Enable, set-point access via the menu system is controlled by the digital input state and not by the password. Set points can always be changed using communications and the password.

When password access is active, all set points are locked from changes until the four-character password is entered. If set-point access is locked, the user is prompted to enter the password. Once entered, set-point access is allowed and remains enabled until a key has not been pressed for the time defined by the *Password Timeout* set point.

Set points are selected either by entering alphanumeric characters or by choosing from a list.

EXAMPLE:

Prior to password entry:

```
LR CURRENT
= 6.75 x FLA
Locked! Press ↵ To
Enter Password.
```

Press ENTER. The *Password Entry* display is shown:

```
PASSWORD ENTRY
Enter Password
And Press ↵
[****]
```

Use the left- and right-arrow keys to select the position of the flashing cursor. Use the up- and down-arrow keys to select password characters. Press ENTER.

When the correct password is entered, a flashing cursor is displayed, the set-point range and units are shown, and the set point can be changed.

```
LR CURRENT
= 6.75 x FLA
(1.00 ÷ 10.00 x FLA)
[0005.25]
```

Use the up- and down-arrow keys to change a set-point update-field character, and use the left- and right-arrow keys to move between characters. Press ENTER to update the set point, or press ESC to exit the display without changing the set point. A set point is set to the minimum or maximum value of its range if an out-of-range value is entered. Press ESC to exit the set-point-update screen.

The sequence for set-point characters depends upon the set-point type. The character sequence for numeric set points is:

... 0 1 2 3 4 5 6 7 8 9 . 0 1 2 3

The character sequence for string set points is:

... [0...9] [A...Z] [a...z] SP - . / [0...9] [A...Z]

Characters forming a series are shown in brackets and "SP" represents the space character.

For set points requiring selection from a list, the up- and down-arrow keys are used to scroll through the items. In the same manner as menu items, selections are displayed using one of the three cursor symbols (⤴ ⤵ ⤶) preceding the item. Pressing ENTER selects the item. The selected item is indicated by the "*" symbol to its right.

EXAMPLE:

```
JAM TRIP ACTION
Disabled          *
*Trip 1
Trip 2
```

4.6 PGA-0120

Menu: *Setup | Hardware | RTD Modules*

Menu: *Setup | Protection | RTD Temperature*

The PGA-0120 module extends PGR-6200 protective functions to include multiple-RTD temperature monitoring. It has eight inputs that can be individually configured for RTD type, trip and alarm settings, name, and function. The RTD types are 10-Ω copper, 100-Ω nickel, 120-Ω nickel, and 100-Ω platinum. Functions are stator, bearing, load, and ambient.

Control voltage for the PGA-0120 (24 Vdc) is supplied by the PGR-6200 and communication is through a TIA-485 link. This allows the PGA-0120 to be mounted up to 1.2 km (4,000') from the PGR-6200.

To enable RTD protection, the total number of modules must be selected in the *Total Modules* menu. Up to three modules can be used. In the *RTD Modules* menu, the action to be taken by the PGR-6200 in response to loss of communication is selected.

When the hardware has been configured, temperature set points in the *RTD Temperature* menu are used for RTD temperature protection. See Section 5.16.

4.7 PGA-0140

Menu: *Setup | Hardware | DIF Module*

Menu: *Setup | Protection | Differential*

The PGA-0140 Differential Module extends PGR-6200 protection functions to include phase-differential monitoring. It has three differential-CT inputs that can be used in a three-CT core-balance connection, a six-differential-CT connection, or a six-CT connection that includes PGR-6200 phase-CT inputs. The core-balance three-CT connection is recommended.

Control voltage for the PGA-0140 (24 Vdc) is supplied by the PGR-6200 and communication is through an RS-485 link. This allows the PGA-0140 to be mounted up to 1.2 km (4,000') from the PGR-6200, and the link can be shared by other PGR-6200 I/O modules.

Enable the module and loss-of-communications protection in the *Hardware | DIF Module* menu, and choose protection settings in the *Protection | Differential* menu. See Section 5.12.

This page intentionally left blank.

5. PROTECTIVE FUNCTIONS

5.1 General

The PGR-6200 measures true RMS, peak, and fundamental-frequency values of current. Fundamental-frequency values (magnitude and phase angle) are obtained using Discrete-Fourier Transform (DFT) filtering that rejects dc and harmonics. The type of measurement used for a protective function is indicated in each section.

Unless otherwise indicated, protective functions have a programmable definite-time characteristic. Each protective function can be assigned a trip action that defines the output contact(s) used. Except for overload protection which has auto-reset available, PGR-6200 trips are latched. Trip actions are logged.

Trip-action selections are:

- Disable
- Trip1
- Trip2
- Trip3
- Trip1 and Trip2
- Trip1 and Trip3
- Trip1 and Trip2 and Trip3
- Trip2 and Trip3

Most protection functions can be assigned an alarm action. Alarm actions are auto-reset and are not logged.

Alarm-action selections are:

- Disable
- Alarm1
- Alarm2
- Alarm3
- Alarm1 and Alarm2
- Alarm1 and Alarm3
- Alarm1 and Alarm2 and Alarm3
- Alarm2 and Alarm3

To operate output contacts, trip and alarm actions must be assigned to output relays using the *Setup | Relay Outputs* menu. See Section 4.2.4.

When enabled, Jam and Undercurrent protection are not active during a start and are active in the Run mode. The Run mode is initiated when motor current is between 5 and 125% FLA for the duration of *Run-Mode Delay*.

Note: See Appendix B for default set-point values. Per-unit notation (pu) is used. 1 pu = 100%.

5.2 Overload

5.2.1 Thermal Model

Menu: *Setup | Protection | Overload*

Menu: *Setup | System Ratings*

A NEMA- or K-factor-based thermal-model algorithm can be selected.

The NEMA-based algorithm uses the square of the maximum RMS phase current as the thermal-model input:

$$I^2 = I_{max\ rms}^2 \quad I \text{ in per unit}$$

The K-factor-based algorithm uses a thermal-model input based on true positive- and negative-sequence component values:

$$I^2 = I_1^2 + kI_2^2 \quad I \text{ in per unit}$$

Where :

I_1 = positive sequence current

I_2 = negative sequence current

k = factor relating the heat produced by I_2 relative to I_1

A conservative value for k is:

$$k = \frac{230}{I_L^2}$$

Where :

$$I_L = \frac{\text{locked rotor current}}{\text{full load current}}$$

The thermal time constant (τ) used by the thermal model to provide starting and running I^2t protection is:

$$\tau = \frac{T_C}{-\ln\left(1 - \frac{sf^2}{I_L^2}\right)}$$

Where :

T_C = cold locked rotor time in seconds

sf = service factor in per unit

When the motor is stopped, the thermal model uses a time constant that is user selectable as a multiple (*Cooling Factor*) of the thermal time constant.

The cold-curve time-to-trip (t) for current above $FLA \times sf$ is:

$$t = -\ln\left(1 - \frac{sf^2}{I^2}\right) \times \tau$$

The PGR-6200 provides indication of thermal trend and used thermal capacity. Thermal trend is the value that used thermal capacity is tending toward and it is a function of the square of motor current. For current greater than or equal to $FLA \times sf$, time-to-trip is displayed in *Metering | Thermal Capacity*. The thermal trend value (Trend I^2t) is:

$$Trend I^2t = \left(\frac{I^2}{sf^2} \right) \times 100\%$$

For currents less than $FLA \times sf$, the thermal trend value is:

$$Trend I^2t = \left(\frac{I^2}{sf^2} \right) \times \left(\frac{T_C - T_H}{T_C} \right) \times 100\%$$

Where :

T_H = hot locked rotor time in seconds

The curve shown in Fig. 5.1 is a Class-20 thermal-protection curve (20-s trip @ 600% FLA) with a service factor of 1.15. FLA multiplied by service factor is the current at which used thermal capacity begins to tend towards a trip. Time-to-trip approaches infinity when $I = FLA \times sf$. Service factor has little influence on time-to-trip when motor current is greater than 300% FLA.

PGR-6200 thermal-overload protection is dynamic. Time to trip at any overload current depends on the value of *Used I^2t* —as *Used I^2t* increases, time to trip decreases. This is illustrated in Fig. 5.1 by the protection curves labeled 25% Used I^2t , 50% Used I^2t , and 75% Used I^2t .

An overload alarm occurs when *Used I^2t* reaches the *I^2t Alarm Level* set point.

An overload trip occurs when *Used I^2t* reaches 100%. When an overload trip occurs, reset is not allowed until *Used I^2t* falls below the *I^2t Inhibit Level* set point. The time-to-reset in minutes is:

$$t = -\tau \times Cooling Factor \times \ln(I^2t Inhibit Level)/60$$

Time-to-reset is displayed in the *Metering | Thermal Capacity* menu. The thermal model has three reset modes; *Normal*, *Auto*, and *Multiple Motor Seq.* The thermal overload reset mode is set using the *Setup | Protection | Overload | I^2t Reset Type* menu.

In the *Normal* mode, a thermal-overload trip reset is not allowed until *Used I^2t* falls below the *I^2t Inhibit Level* setting. A manual reset is required to reset the trip. *Normal* is the default reset mode.

In the *Auto* mode, a thermal-overload trip is automatically reset when *Used I^2t* falls below the *I^2t Inhibit Level* setting.

Caution:

If the starter circuit is configured for two-wire control, the motor can start without warning when *Auto* mode is selected. A warning label may be required.

In the *Multiple Motor Seq.* mode, *Used I^2t* decreases exponentially with a fixed two-second time constant when there is no motor current. This mode is used in applications where one overload relay is used to protect several motors operating in sequence with only one motor running at any one time. A two-second stop is required between starts so that *Used I^2t* decreases sufficiently to allow the next motor to start. It is assumed that each motor is allowed to cool between starts. Motor life may be decreased if this feature is used in single-motor applications.

When *I^2t Inhibit* is enabled, the *I^2t Inhibit Level* set point can be used to prevent a start with insufficient I^2t available. Both trip and alarm selections are provided. When *Used I^2t* is above the *I^2t Inhibit Level* set point and motor current is not detected, a trip or alarm is issued and the relay assigned to *Start Inhibit* is energized. The time until a start is permitted is displayed in *Metering | Thermal Capacity*, and *I^2t Inhibit Alarm* is displayed in the *Trip and Alarm* message window. When *Used I^2t* falls below the *I^2t Inhibit Level* set point or when current is detected the relay assigned to *Start Inhibit* is de-energized, and the inhibit alarm is cancelled. Trips require a manual reset unless the reset type is set to auto. The Start-Inhibit relay is shared with the Starts-Per-Hour function. See Section 5.13.

If the motor is equipped with RTD sensors, the thermal model can compensate for high ambient temperature and loss of ventilation. See Section 5.17.

I^2t used during each start is recorded in *Messages | Event Records*. This information can be used to determine the *I^2t Inhibit Level* set point to ensure sufficient I^2t is available to complete a start, and to minimize thermal-overload-reset time.

FLA Rating.....	1.00 to 5,000.00 A
Service Factor	1.00 to 1.25
Locked-Rotor Current	1.50 to 10.00 x FLA
Hot Locked-Rotor Time	0.10 to 100.00 s
Cold Locked-Rotor Time.....	0.10 to 100.00 s
Cooling Factor	0.10 to 10.00
Model Type:.....	NEMA, K-Factor
I^2t Reset Type.....	Normal, Auto, Multiple Motor Sequence
K-Factor.....	1.00 to 10.00
I^2t Trip.....	1.00 pu
I^2t Alarm.....	0.50 to 1.00 pu
I^2t Inhibit Level.....	0.10 to 0.90 pu
I^2t Inhibit.....	Enable/Disable Trip1, 2, 3 Enable/Disable Alarm 1, 2, 3



Protection.....Enable/Disable Trip1, 2, 3
Enable/Disable Alarm1, 2, 3
Measurement Method.....DFT or RMS

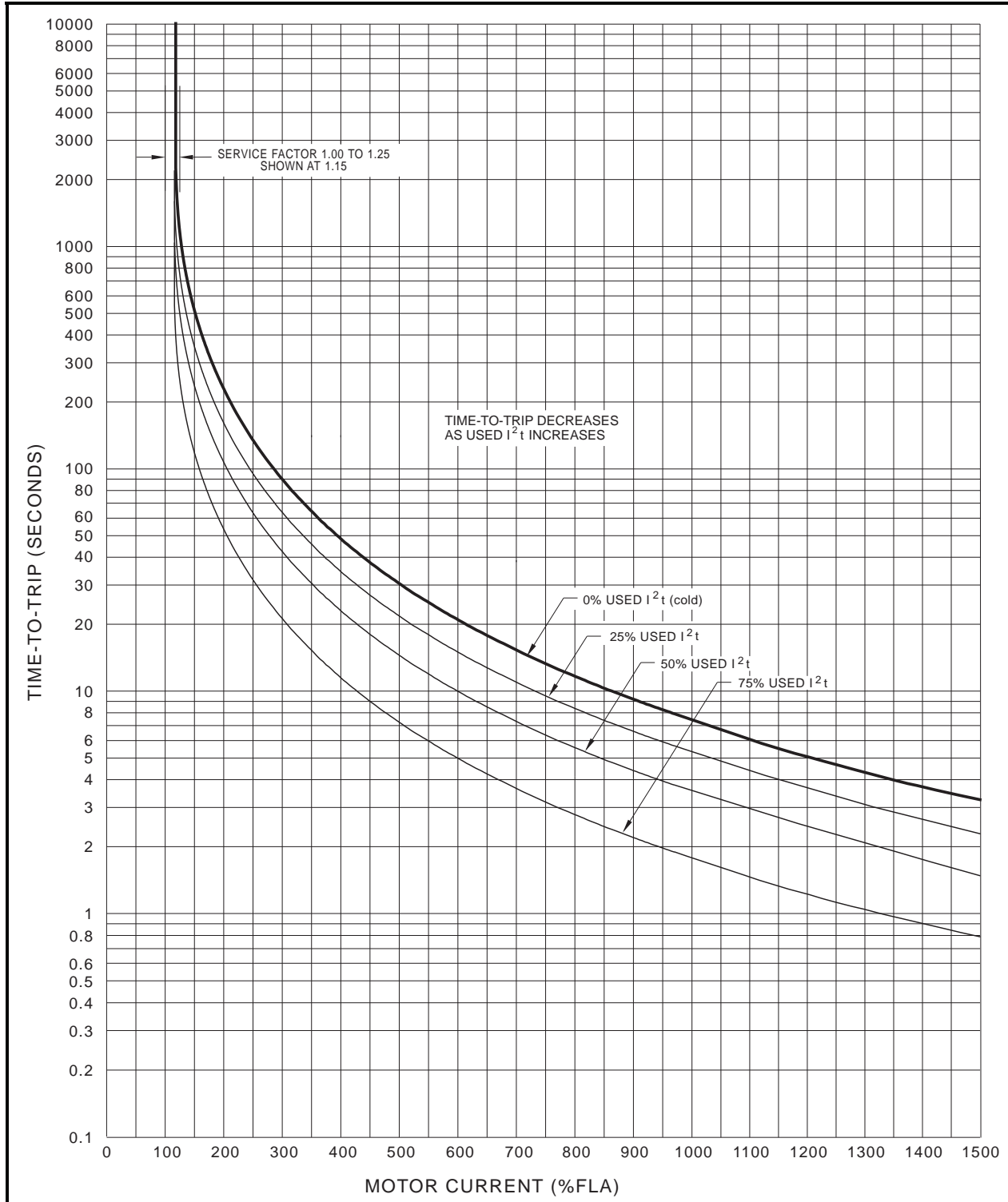

FIGURE 5.1 Class-20 Overload Curve.

5.2.2 Locked-Rotor Times

In all cases, values for T_H and T_C should be obtained from the motor manufacturer. The following information is provided to assist in selecting values for T_H and T_C only if manufacturer data is not available.

Heater-style overload elements are available as Class 10, Class 20, or Class 30. Class 20 is recommended for general applications, Class 10 is used for motors with short locked-rotor time capability, and Class 30 is used in high-inertia applications to allow additional accelerating time where motors are within Class-30 performance requirements. These overloads can be replicated by setting $T_C = 10, 20, \text{ or } 30 \text{ s}$; $T_H = 0.1 \text{ s}$; and Locked-Rotor Current = $6.00 \times \text{FLA}$.

An induction motor built to the NEMA MG 1 standard is capable of

- two starts in succession (coasting to rest between starts) with the motor initially at ambient temperature (cold start), and
- one start with the motor initially at a temperature not exceeding its rated-load operating temperature (hot start).

Since the connected load has a direct influence on motor heating during a start, NEMA MG 1 defines the load torque and the load inertia (Wk^2) for these starts as a function of the motor's rated power and synchronous speed. To satisfy the cold-start requirement, a start must not use more than 50% thermal capacity. To satisfy the hot-start requirement, used thermal capacity at steady state must be less than 50%.

If the thermal model in the PGR-6200 has the correct value of T_C and if $Used \int t$ increases by 50% during a start, the load is equal to the NEMA-defined load and two starts from cold will be permitted. If $Used \int t$ increases by more than 50% during a start, the load is greater than the NEMA-defined load and two starts from cold should not be permitted — a delay is required between starts. The appropriate delay can be obtained by enabling $\int t \text{ Start Inhibit}$ and setting the $\int t \text{ Inhibit Level}$ equal to 100% minus the $\int t$ used during a start (a slightly lower level is recommended to allow for supply and load variations). If $Used \int t$ increases by less than 50% during a start, the load is less than the NEMA-defined load and two starts from cold will be permitted.

The magnitude of T_H relative to T_C determines if a hot start will be permitted if $\int t \text{ Start Inhibit}$ is enabled and the $\int t \text{ Inhibit Level}$ is set as described above. If $Used \int t$ increases by 50% or less during a start, a hot start will be permitted if T_H is equal to or greater than 50% of T_C . Increasing T_H above

50% of T_C is not recommended unless specific information is available with respect to T_H .

5.2.3 Emergency Thermal Reset

Menu: *Messages | Emerg $\int t$ Reset | Reset $\int t$ Memory*

Emergency Thermal Reset (ETR) sets $Used \int t$ to 0%, resets starts-per-hour variables, and disables PTC and RTD temperature trips. Program access is required. Disabled-temperature protection is indicated by $t^\circ \text{ Disabled by ETR}$ in the *System State* display. If PTC or RTD temperature protection is not enabled, $t^\circ \text{ Disabled by ETR}$ will not be displayed. Stator RTD or PTC trips are reset when ETR is performed regardless of measured temperatures. Temperature protection must be re-enabled in the *Messages | Emerg $\int t$ Reset | Reenable Temp* menu, or by cycling supply voltage. Disabled-temperature protection can be assigned to the user-programmable indication LED. See Section 4.1.1

Temperature alarms and sensor verification remain enabled during ETR.

Caution:

Temperature protection is not automatically re-enabled after an Emergency Thermal Reset.

5.3 Overcurrent

Menu: *Setup | Protection | Overcurrent*

Overcurrent protection is based on the largest fundamental-frequency component (DFT) of the three phase currents. An alarm-level setting is not provided.

When enabled, overcurrent protection is active at all times — it is not bypassed during a start.

Fault duration required for a trip is a function of the Trip Time setting and the fault level. Table 5.1 shows the required fault duration for three fault-level values.

TABLE 5.1 Fault Duration Required for Trip or Alarm

FAULT LEVEL ⁽¹⁾ (multiples of trip-level setting)	FAULT DURATION ⁽²⁾ (ms)	
	TD \leq 30 ms	TD > 30 ms
2	10	TD – 20
5	5	TD – 25
10	2	TD – 28

⁽¹⁾ For overcurrent less than 15 x CT-Primary Rating.
For earth faults less than 1 x EF-CT-Primary Rating.

⁽²⁾ Fixed frequency, 60 Hz.

The asymmetrical-current multipliers for RMS and DFT measuring methods are shown in Fig. 5.2. To prevent false overcurrent trips during starting, the Trip Level setting must be above the product of

locked-rotor current and the multiplier. Typical X/R values are 6.6 for a low-voltage system, 15 for a medium-voltage system, and can be as high as 25 for a high-voltage system. The DFT filters the dc component so that the overcurrent setting can be set closer to the symmetrical fault value.

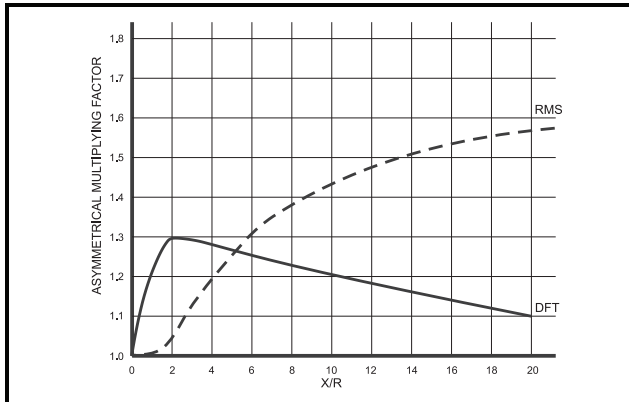

FIGURE 5.2 Asymmetrical-Current Multipliers

Trip Level 1.00 to 15.00 × CT-Primary Rating (I_p)
 Trip Delay (TD) 0.00 to 10.00 s
 Trip Time (TD + 35 ms) ± 10 ms
 See Table 5.1
 Protection Enable/Disable Trip1, 2, 3
 Measurement Method DFT with CT-saturation compensation

5.4 Auxiliary Overcurrent

Menu: *Setup | Protection | Aux Overcurrent*

Auxiliary overcurrent provides an additional definite-time overcurrent element for the protection curve. It can also be used to trip an up-stream device when backup protection for the overcurrent function is required.

Setting ranges are the same as the overcurrent function.

Trip Level 1.00 to 15.00 × CT-Primary Rating (I_p)
 Trip Delay (TD) 0.00 to 10.00 s
 Trip Time (TD + 35 ms) ± 10 ms
 See Table 5.1
 Protection Enable/Disable Trip1, 2, 3
 Measurement Method DFT with CT-saturation compensation

5.5 Reduced Overcurrent

Menu: *Setup | Protection | Reduced OC*

Reduced overcurrent is used to reduce the overcurrent set point when performing maintenance in a motor circuit when the motor is running.

Reduced overcurrent is controlled by the digital input assigned to *Reduced OC*. When the digital-

input voltage is not applied, this set point is operational and when the digital input voltage is applied, this set point is not operational. When reduced overcurrent is selected, *ROC:On* is displayed in the *Metering | System Status* menu, the relay assigned to *Reduced OC* will be energized, and if assigned, the UPI LED will be on.

The trip level should be set just above the full-load current of the motor. To avoid trips on starting *Reduced OC* should not be selected until the motor is running.

The Protection selection must include Trip1, Trip2, or Trip3. If *Disable* is selected, reduced overcurrent mode is disabled.

Trip Level 1.00 to 15.00 × CT-Primary Rating (I_p)
 Trip Delay Fixed at 0.00 (Instantaneous)
 See Table 5.1
 Protection Enable/Disable Trip1, 2, 3

5.6 Jam

Menu: *Setup | Protection | Jam*

A trip or alarm occurs if a jam condition is detected. Jam protection is active when the motor is in the Run mode, allowing protection to be set below motor-starting current.

Trip Level 1.00 to 10.00 × FLA
 Trip Delay 1.00 to 100.00 s
 Alarm Level 1.00 to 10.00 × FLA
 Alarm Delay 1.00 to 100.00 s
 Protection Enable/Disable Trip1, 2, 3
 Enable/Disable Alarm1, 2, 3
 Measurement Method DFT

5.7 Earth Fault

Menu: *Setup | Protection | Earth Fault*

Menu: *Setup | System Ratings*

The *EF Source* menu selects the earth-fault source as *Calculated ($3I_0$)* or *Measured (I_{ct})*. The *Calculated ($3I_0$)* selection uses the $3I_0$ value obtained from the sequence-component calculation and is based on phase currents only; an earth-fault CT is not required. The *Measured (I_{ct})* selection uses the CT input and should be selected when an earth-fault-CT or the residual-CT connection is used.

For the *Calculated ($3I_0$)* selection and for the residual connection, I_e corresponds to the CT-Primary Rating. For the *Measured (I_{ct})* selection, I_e corresponds to the EF-CT Primary Rating.

Note: Calculated $3I_0$ does not detect CT saturation. Enable overcurrent protection when earth-fault current can exceed 18 times the phase-CT primary rating.

Trip Level	0.01 to $1.00 \times$ Earth-Fault-CT-Primary Rating (I_e)
Trip Delay (TD)	0.00 to 100.00 s
Trip Time.....	(TD + 35 ms) \pm 10 ms See Table 5.1
Alarm Level.....	0.01 to $1.00 \times I_e$
Alarm Delay	0.00 to 100.00 s
Alarm Time	(TD + 35 ms) \pm 10 ms See Table 5.1
Protection	Enable/Disable Trip1, 2, 3 Enable/Disable Alarm1, 2, 3
Measurement Method	DFT

I_e is 5 A for PGC-3026, PGC-3082, or PGC-3140.

5.8 Current Unbalance

Menu: *Setup | Protection | Unbalance*

Positive-sequence current (I_1) and negative-sequence current (I_2) are used to determine current unbalance (I_2/I_1). The unbalance display range is 0.00 to 1.00 where 1.00 is 100% unbalance—a single-phase condition. Negative unbalance will be indicated if current inputs are connected B-A-C. Severe unbalance may be indicated if phase-CT polarity is incorrect.

Trip Level	0.05 to 1.00
Trip Delay	1.00 to 100.00 s
Alarm Level.....	0.05 to 1.00
Alarm Delay	1.00 to 100.00 s
Protection.....	Enable/Disable Trip1, 2, 3 Enable/Disable Alarm1, 2, 3
Measurement Method	DFT

5.9 Phase Loss

Menu: *Setup | Protection | Phase Loss*

Phase loss is a severe form of unbalance. When phase loss occurs, negative-sequence current (I_2) is equal to positive-sequence current (I_1) and current unbalance is 100% or 1.00 pu. The phase-loss algorithm considers I_2/I_1 from 0.90 to 1.00 to be a phase loss. Set the phase-loss trip delay lower than the unbalance trip delay to avoid an unbalance trip in the event of a phase loss.

Note: Disconnecting a phase CT does not cause a phase loss because proper rotation is still observed on the other two phases.

Trip Delay.....	1.00 to 100.00 s
Alarm Delay	1.00 to 100.00 s
Protection.....	Enable/Disable Trip1, 2, 3 Enable/Disable Alarm1, 2, 3
Measurement Method	DFT

5.10 Phase Reverse

Menu: *Setup | Protection | Phase Rev*

If the current phase sequence is B-A-C, the magnitude of negative-sequence current will be larger than the magnitude of positive-sequence current.

Trip Delay.....	1.00 to 100.00 s
Alarm Delay	1.00 to 100.00 s
Protection.....	Enable/Disable Trip1, 2, 3 Enable/Disable Alarm 1, 2, 3
Measurement Method	DFT

5.11 Undercurrent

Menu: *Setup | Protection | Undercurrent*

Undercurrent protection is loss-of-load protection and is active when the motor is in the Run mode. A trip or alarm is initiated if current remains below the set point for the programmed delay.

Trip Level	0.10 to $1.00 \times$ FLA
Trip Delay.....	1.00 to 100.00 s
Alarm Level.....	0.10 to $1.00 \times$ FLA
Alarm Delay	1.00 to 100.00 s
Protection.....	Enable/Disable Trip1, 2, 3 Enable/Disable Alarm1, 2, 3
Measurement Method	DFT

5.12 Differential Current Protection

Menu: *Setup | Protection | Differential*

Menu: *Setup | Hardware | DIF Module*

Menu: *Setup | System Ratings | DF-CT Primary*

The PGA-0140 provides three-phase differential protection. It is intended to be used specifically for motor protection and not intended for feeder or transformer differential protection.

Enable the module and communications-loss protection using the *Setup | Hardware | DIF Module* menu. The module uses I/O module communications and both trip and alarm actions are available in the event of communications loss.

Set *DF-CT Primary* equal to the differential-CT-primary rating. For the summation connection, phase-CT Primary must be equal to *DF-CT Primary*.

Trip and alarm settings are based on multiples of the *DF-CT Primary* rating (I_d).

Trip Level	0.10 to 15.00 x I _d
Trip Delay	0.00 to 10.00 s
Alarm Level.....	0.10 to 15.00 x I _d
Alarm Delay	0.00 to 10.00 s
Protection.....	Enable/Disable Trip1, 2, 3 Enable/Disable Alarm1, 2, 3
Measurement Method.....	DFT c/w CT-saturation compensation.

5.13 Starts Per Hour / Time Between Starts

Menu: *Setup | Protection | Starts Per Hour*

Starts-Per-Hour and Time-Between-Starts are useful limits in a protective relay that incorrectly responds to current below FLA. If the relay's thermal model accurately tracks a motor's used thermal capacity under all conditions, Starts-Per-Hour and Time-Between-Starts are features that provide no additional protection. The PGR-6200 does not require these features to provide protection, but they are included to satisfy protection strategies designed for protective relays without dynamic thermal modeling.

The Starts-Per-Hour feature ensures that the programmed number of starts per hour is not exceeded and the Time-Between-Starts feature ensures that the programmed time has elapsed between starts. The available number of starts and time between starts is also a function of the thermal model's *Used I²t* value. Consequently, the number of starts may be less than the starts-per-hour value and the time between starts may be longer than the set-point value.

The number of starts and time between starts is checked when the motor is stopped. A *Starts/Hour Trip* or *Starts/Hour Alarm* is issued if a start will exceed the # *Starts Per Hour* setting or if the time since the previous start is less than the *Time Between* setting.

When a *Starts/Hour Trip* or *Starts/Hour Alarm* is issued, the output relay assigned to *Start Inhibit* is energized. The *Start Inhibit* relay is non-latching and can be used as a start permissive. A *Starts/Hour Trip* will remain latched until a reset is issued. The *Start Inhibit* relay is shared with the thermal model's *I²t Inhibit* feature.

If motor current is detected regardless of the alarm or trip condition, the *Starts/Hour Alarm* is removed, and *Starts/Hour Trip* can be reset. The starts-per-hour algorithm remains active but any trips or alarms are suppressed until the motor is stopped.

The status of Starts-Per-Hour and Time-Between-Starts is displayed in the *Metering | Thermal Capacity* menu. If there are no trips or alarms, the number of available starts (*Sph Available*) is displayed and if a trip or alarm is

present, the inhibit time (*Sph Inhibit*) is displayed. Since the *Metering | Thermal Capacity* menu is also used to display the thermal model status, messages are prioritized as follows:

- I²t Reset Time⁽¹⁾
- I²t Trip Time⁽¹⁾
- I²t Inhibit Time⁽¹⁾
- Starts Per Hour Inhibit Time⁽³⁾
- Starts Available^{(2) (3)}

An Emergency Thermal Reset (ETR) can be used to initialize all thermal and starts-per-hour variables and to reset a starts-per-hour trip. See Section 5.2.3.

Time Between Starts.....	0.00 to 500.00 Minutes
Starts Per Hour ⁽²⁾	1 to 10
Protection.....	Enable/Disable Trip 1, 2, 3 Enable/Disable Alarm 1, 2, 3

- (1) Calculated from thermal model data.
 (2) The display range for the number of available starts is -9 to +10.
 (3) Initialized when supply voltage is cycled.

5.14 PTC Temperature (Local)

Menu: *Setup | Hardware | Local Temp Sensor*

Menu: *Setup | Protection | PTC Temperature*

The local-temperature-sensor input is configured for a positive-temperature-coefficient (PTC) thermistor sensor using the *Setup | Hardware | Local Temp Sensor* menu.

The total resistance of series-connected PTC thermistors must be less than 1,500 Ω at 20°C. A trip or alarm will occur when series resistance exceeds 2,800 Ω.

During Emergency Thermal Reset, a PTC trip is reset and PTC-temperature protection is disabled. See Section 5.2.3.

Protection	Enable/Disable Trip1, 2, 3 Enable/Disable Alarm1, 2, 3
------------------	---

5.15 RTD Temperature (Local)

Menu: *Setup | Hardware | Local Temp Sensor*

Menu: *Setup | Protection | RTD Temperature*

The local-temperature-sensor input is configured for a Pt100 RTD sensor using the *Setup | Hardware | Local Temp Sensor* menu.

Sensor verification is enabled using the *Sensor Trip Act* and *Sensor Alarm Act* Action menus. When a sensor failure is detected, the corresponding protection is disabled.

During Emergency Thermal Reset, an RTD trip is reset and RTD-temperature protection is disabled. See Section 5.2.3.

6. THEORY OF OPERATION

6.1 Signal-Processing Algorithm

The PGR-6200 obtains thirty-two samples per cycle of each current signal — the sampling frequency is 1.6 kHz in 50-Hz applications and 1.92 kHz in 60-Hz applications. If variable frequency is selected, the phase-A-current signal controls the sampling frequency to obtain thirty-two samples per cycle of each current signal.

A Discrete-Fourier-Transform (DFT) algorithm is used to obtain the magnitudes and phase angles of the fundamental-frequency components of the current waveforms. These values provide true positive-, negative-, and zero-sequence components. True RMS values of phase currents include up to the 16th harmonic. Fundamental-frequency values are displayed.

Peak-to-peak currents are measured and compared to DFT values to compensate for CT saturation.

6.2 Temperature Input Module (PGA-0120)

The temperature input module contains a microprocessor, A/D converter, and a multiplexer to measure up to eight RTD's. The RTD-measuring circuit is isolated from the I/O Module network. All eight RTD's are scanned every three seconds. RTD linearization, open/short detection, and lead compensation are performed by the Temperature Input Module. RTD temperature is sent to the PGR-6200 where temperature monitoring occurs.

6.3 Differential Current Module (PGA-0140)

The differential module obtains 32 samples per cycle of the differential currents. A Discrete-Fourier-Transform (DFT) algorithm is used to obtain the magnitude of the three differential currents. Frequency of operation is set by the PGR-6200 and allows differential protection to be used in variable-frequency drive applications. The DFT values are sent to the PGR-6200 where differential protection is performed.

This page intentionally left blank

7. COMMUNICATIONS

7.1 Personal-Computer Interface

7.1.1 Firmware Upgrade

The PGR-6200 control program is stored in flash memory. Field updates can be made through the TIA-232 communication interface located on the rear panel. The following are required:

- A Windows[®] PC, a TIA-232 interface, and the PGW-FLSH program,
- a file containing the PGR-6200 control program (.s19 file), and
- an RJ-45 to DB9 adapter (PGA-0420).

PGW-FLSH is available at www.littelfuse.com and a PGA-0420 adapter is available from Littelfuse Inc.

7.1.2 PGW-COMM

PGW-COMM is a Windows-based program used to access PGR-6200 functions with a personal computer (PC) via the TIA-232 or optional TIA-485 and Ethernet interfaces. Use PGW-COMM to program a PGR-6200 either by changing individual set points or by downloading set-point files. Existing PGR-6200 set points can be transferred to the PC. Metered values can be viewed and the PGR-6200 can be controlled with the computer. PGW-COMM extends the event-record storage capability of the PGR-6200 by allowing the user to transfer data to PC memory at a programmable interval. Protection curve plotting capability is included. PGW-COMM is available at www.littelfuse.com.

7.2 Network Interface

For detailed information see Appendices to this manual and applicable communications manuals.

7.2.1 TIA-485 Option

The TIA-485 communications option supports Modbus RTU and Allen-Bradley DF1 half-duplex protocols. All set points and meter values are accessible. Commands are provided to perform trips, resets, and remote relay control.

Modbus RTU function codes supported:

- Read Holding Registers (Code 3)
- Read Input Registers (Code 4)
- Write Single Register (Code 6)
- Write Multiple Registers (Code 16)
- Command Instruction (Code 5)

DF1 Commands Supported:

- Unprotected Read (CMD = 01)
- Unprotected Write (CMD = 08)
- Typed Read (CMD = 0F, FNC = 68)
- Typed Write (CMD = 0F, FNC = 67)
- Typed Logical Read (CMD = 0F, FNC = A2)
- Typed Logical Write (CMD = 0F, FNC = AA)

7.2.2 DeviceNet Option

The DeviceNet communications option supports Explicit Messaging and Polled I/O. All set points and meter values are accessible using Explicit Messaging. The Polled I/O connection supports the following ODVA input assemblies:

- Basic Overload (50)
- Extended Overload (51)
- Basic Motor Starter (52)
- Extended Motor Starter (53)

In addition to the ODVA assemblies, a user-configurable fixed block of 64 bytes is available.

The Polled I/O connection supports the following ODVA output assemblies:

- Basic Overload (2)
- Basic Motor Starter (3)

An Electronic Data Sheet (EDS) file is provided for use with DeviceNet configuration tools such as RSNetWorx and DeltaV.

7.2.3 Ethernet Option

The Ethernet option supports the Modbus TCP protocol. Modbus TCP uses TCP/IP to encapsulate the Modbus RTU protocol. Up to five simultaneous connections are supported. In addition to the Modbus RTU function codes listed in Section 7.2.1 the Read Device Identification Code (43) is supported.

The PGR-6200 Modbus TCP interface is compatible with PGW-COMM Version 1.5 and above. See Section 7.1.2.

This page intentionally left blank

8. TECHNICAL SPECIFICATIONS

8.1 PGR-6200

Supply.....30 VA, 65 to 265 Vac,
 40 to 400 Hz.
 25 W, 80 to 275 Vdc.

Power-Up Time800 ms at 120 Vac

Ride-Through Time100 ms minimum

24-Vdc Source ⁽¹⁾400 mA maximum

AC Measurements:

Methods.....True RMS, DFT, Peak,
 and positive- and
 negative- sequence
 components of the
 fundamental.

Sample Rate32 samples/cycle.

Frequency:

Fixed.....50 or 60 Hz

Variable10 to 90 Hz

Accuracy0.5 Hz

Phase-Current Measurement: ⁽²⁾

Metering Range.....15 x CT-Primary Rating (I_p)

Protection Range80 x I_p

Metering Accuracy: ^(3,4)

$I < I_p$2% I_p

$I > I_p$2% Reading

Unbalance Accuracy0.02 pu

Earth-Leakage Measurement:

Range.....1.5 x Earth-Fault-CT-
 Primary Rating (I_e)

Accuracy ^(3, 4)2% I_e

PTC-Thermistor Input: ^(1, 5)

Cold Resistance1,500 Ω maximum at 20°C

Trip Level.....2,800 $\Omega \pm 200 \Omega$

Reset Level1,500 $\Omega \pm 200 \Omega$

Sensor Current.....1 mA maximum

RTD Input: ^(1, 5)

RTD Type.....3 wire Pt100

Range.....-40 to 260°C with open
 and short detection

Sensor Current.....1 mA

Lead Compensation25 Ω maximum

Accuracy.....2°C (-40 to 200°C)

5°C (200 to 260°C)

4–20 mA Analog Output:

Type Self powered and loop
 powered

Range.....4 to 22 mA

Update Time250 ms

Loop Supply Voltage.....8 to 26 Vdc

Load500 Ω (maximum with
 24 Vdc supply)

Isolation ⁽¹⁾120 Vac with L/S switch
 in L position

Timing Accuracies: ⁽⁶⁾

Set Point ≤ 1 s.....+5% (minimum
 25 to 45 ms)

Set Point > 1 s.....+2%

Relay Contacts:

Configuration.....N.O. and N.C. (Form C)

UL/CSA Contact Rating..8 A resistive 250 Vac,
 8 A resistive 30 Vdc

Supplemental Contact Ratings:

Make/Carry 0.2 s20 A

Break:

dc50 W resistive,
 25 W inductive (L/R = 0.04)

ac2,000 VA resistive,
 1,500 VA inductive
 (PF = 0.4)

Subject to maximums of 8 A and 250 V (ac or
 dc).

Digital Input: ⁽¹⁾

Range.....12 to 36 Vdc, 5 mA at
 24 Vdc

Guaranteed On12 Vdc at 2 mA

Guaranteed Off3 Vdc at 0.5 mA

Isolation.....120 Vac

I/O Module Interface (PGA-0120, PGA-0140):

Module Supply ⁽¹⁾24 Vdc, 400 mA max.

Configuration.....TIA-485, 2 wire multi-drop

Bus Length.....1.2 km (4,000') max.

Cable.....Belden 3124A or
 equivalent

TIA-232 Communications:

Baud Rate9.6, 19.2, 38.4 kbit/s

Protocol.....Modbus RTU

Address1 to 255

Real-Time Clock:

Power-Off Operation6 Months at 20°C

Battery.....Rechargeable lithium
 (no service required)

Non-Volatile RAM: Power-Off Retention..... 10 Years	Surge Immunity..... IEC 60255-22-5 0.5 & 1.0 kV differential mode (line-to-line) 0.5, 1.0, & 2.0 kV common mode
Shipping Weight2.0 kg (4.4 lb)	
PWB Conformal CoatingMIL-1-46058 qualified UL QMJU2 recognized	DC Voltage Interruption IEC 60255-22-11 100% for 5, 10, 20, 50, 100, & 200 ms interruption time on AC/DC power ports.
Environment: Operating Temperature.-40 to 60°C ⁽⁷⁾ Storage Temperature.....-55 to 80°C Humidity85% Non-Condensing	
Surge Withstand.....ANSI/IEEE C37.90.1-1989 (Oscillatory and Fast Transient)	CertificationCSA, USA and Canada 
EMC Tests: Verification tested in accordance with EN 60255-26:2005.	To: UL 508 Industrial Control Equipment UL 1053 Ground Fault Sensing and Relaying Equipment CSA C22.2 No. 14 Industrial Control Equipment
Radiated RFIEC 60255-22-3 10 V/m, 80-1,000 MHz, 80% AM (1 kHz) 10 V/m, 900 MHz, 200 Hz Pulse Modulated	
Electrostatic Discharge .IEC 60255-22-2 6 kV Constant Discharge 8 kV Air Discharge	
Power FrequencyIEC 60255-22-7 Class A: differential mode 150 Vrms @ 100 Ω/0.1 μF, 300 Vrms @ 220 Ω/0.47 μF Class B: differential mode 100 Vrms @ 100 Ω/0.047 μF, 300 Vrms @ 220 Ω/0.47 μF	
Conducted RFIEC 60255-22-6 10 V, 0.15-80 MHz, 80% AM (1 kHz)	
Fast TransientIEC 60255-22-4 Class A: 4 kV, 2.5 kHz rpf Class B: 2 kV, 5 kHz rpf	
1 MHz BurstIEC 60255-22-1 1 kV differential mode (line-to-line) 2.5 kV common mode	

Notes:

- (1) The I/O module supply and analog output are referenced to the same supply when the L/S switch is in the S position. In the L position, the analog output's isolation is 120 Vac.
- (2) Current threshold is 5% of FLA setting. To maintain specified accuracy, phase CT's should be selected with a primary rating between 100% and 300% of motor full-load current.
- (3) Transformer accuracy not included.
- (4) Accuracy is a function of PGA-0CIM to PGR-6200 cable resistance: % Accuracy = 2 + 0.65 x cable resistance (Ω)
- (5) Local PTC and RTD sensors are mutually exclusive.
- (6) See Table 5.1.
- (7) Display readability decreases at temperatures below -20°C.

8.2 Current Input Module (PGA-0CIM)

CT Inputs:
Thermal Withstand

Continuous	5 x CT-Secondary Rating
1-Second	80 x CT-Secondary Rating

Burden

1- and 5-A inputs....	< 0.01 Ω
EFCT-x input	10 Ω

Interconnection Cable:

Type	Littelfuse S75-P300-20030
Resistance.....	5.3 Ω/100 m (328') ⁽⁴⁾
Supplied Length	6 m (19')

Terminal-Block Ratings:

CT Inputs	25 A, 500 Vac, 10 AWG (4.0 mm ²)
-----------------	---

Shipping Weight0.4 kg (0.9 lb)

 PWB Conformal CoatingMIL-1-46058 qualified
 UL QMJU2 recognized

Environment:

Operating Temperature ..	-40 to 60°C
Storage Temperature	-55 to 80°C
Humidity	85% Non-Condensing

 Surge Withstand.....ANSI/IEEE C37.90.1-1989
 (Oscillatory and Fast Transient)

Certification.....CSA, USA and Canada

To:

UL 508 Industrial Control Equipment
 UL 1053 Ground Fault Sensing and Relaying Equipment
 CSA C22.2 No. 14 Industrial Control Equipment

8.3 Temperature Input Module (PGA-0120)

 Supply ⁽¹⁾ 2 W, 18 to 32 Vdc

Configuration 8 inputs, 3 wire RTD

 RTD Types Pt100, Ni100, Ni120,
 Cu10

 Measurement Range..... -40 to 200°C, with open
 and short detection

Sensor Current..... 2 mA

Lead Compensation 20 Ω maximum

Accuracy:

Pt100, Ni100, Ni120 RTD	1°C
Cu10 RTD	3°C

Interconnection Cable:

Type	Belden 3124A or equivalent
Maximum Length.....	1.2 km (4,000')
Supplied length.....	4 m (13')

Shipping Weight0.4 kg (0.9 lb)

 PWB Conformal CoatingMIL-1-46058 qualified
 UL QMJU2 recognized

Environment:

Operating Temperature ..	-40 to 60°C
Storage Temperature	-55 to 80°C
Humidity	85% Non-Condensing

 Surge Withstand.....ANSI/IEEE C37.90.1-1989
 (Oscillatory and Fast Transient)

CertificationCSA, USA and Canada



Hazardous-Location Class I Zone 2 Ex nA II T6
To:

UL 508 Industrial Control Equipment
 UL 60079-15 Electrical Apparatus for Explosive Gas Atmospheres
 CSA C22.2 No. 14 Industrial Control Equipment
 CSA E60079-15: 02 Electrical Apparatus for Explosive Gas Atmospheres

8.4 Differential Current Module (PGA-0140)

Supply.....2 W, 18 to 32 Vdc

CT Inputs:

Thermal Withstand:

Continuous.....5 x CT-Rating
1-Second.....80 x CT-Rating
Burden.....0.01 Ω

Terminal-Block Ratings:

CT Inputs.....25 A, 500 Vac
10 AWG (4.0 mm²)

Differential-Current Measurement:

Metering Range.....15 x CT-Primary Rating (I_d)
Protection Range80 x I_d
Metering Accuracy:
 $I < I_d$2% I_d
 $I > I_d$2% Reading
Timing Accuracy5%, minimum trip time
 range is set point +20 ms
 to set point +150 ms,
 median 81 ms

Interconnection Cable:

TypeBelden[®] 3124A or
 equivalent
Maximum Length.....1.2 km (4,000')

Shipping Weight0.4 kg (0.9 lb)

PWB Conformal CoatingMIL-1-46058 qualified
 UL QMJU2 recognized

Environment:

Operating Temperature.-40 to 60°C
Storage Temperature....-55 to 80°C
Humidity85% Non-Condensing

Surge Withstand.....ANSI/IEEE C37.90.1-1989
 (Oscillatory and Fast
 Transient)

**APPENDIX A
PGR-6200 MENU MAP**

MAIN MENU

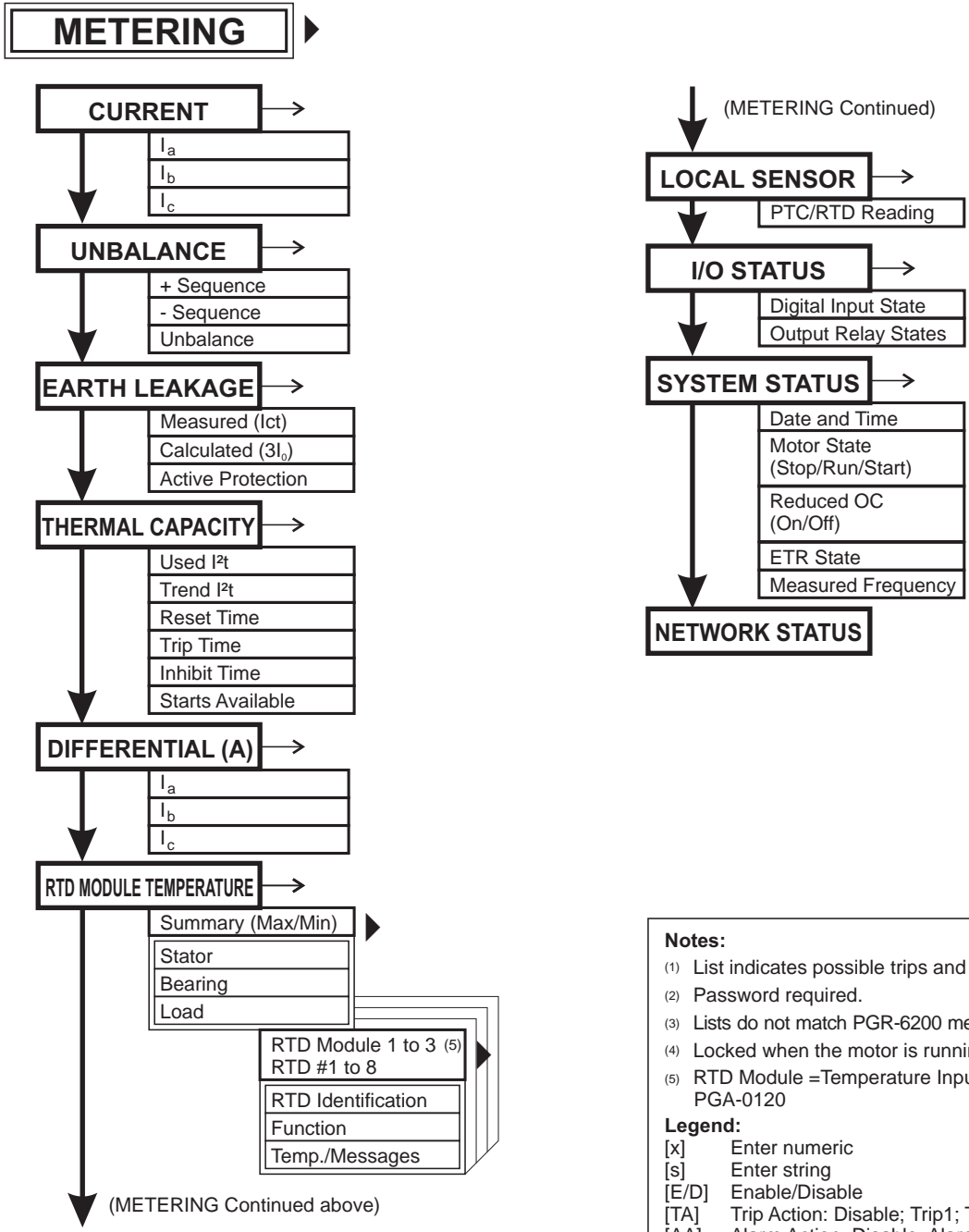

Notes:

- (1) List indicates possible trips and alarms.
- (2) Password required.
- (3) Lists do not match PGR-6200 menu order.
- (4) Locked when the motor is running.
- (5) RTD Module = Temperature Input Module PGA-0120

Legend:

[x] Enter numeric
[s] Enter string
[E/D] Enable/Disable
[TA] Trip Action: Disable; Trip1; Trip2; Trip3
[AA] Alarm Action: Disable; Alarm1; Alarm2; Alarm3
[Y/N] Yes/No
[EA] Ethernet address

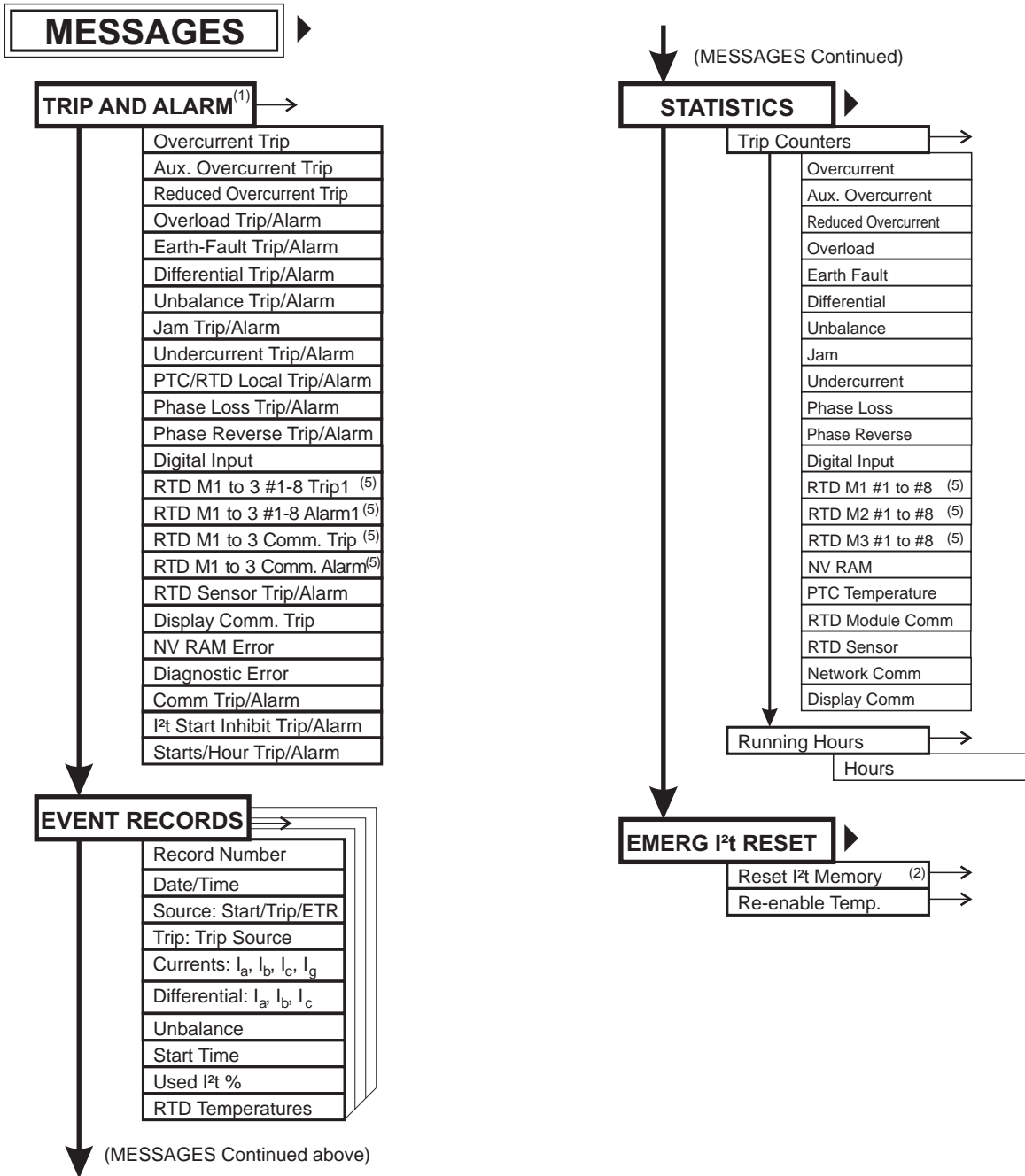

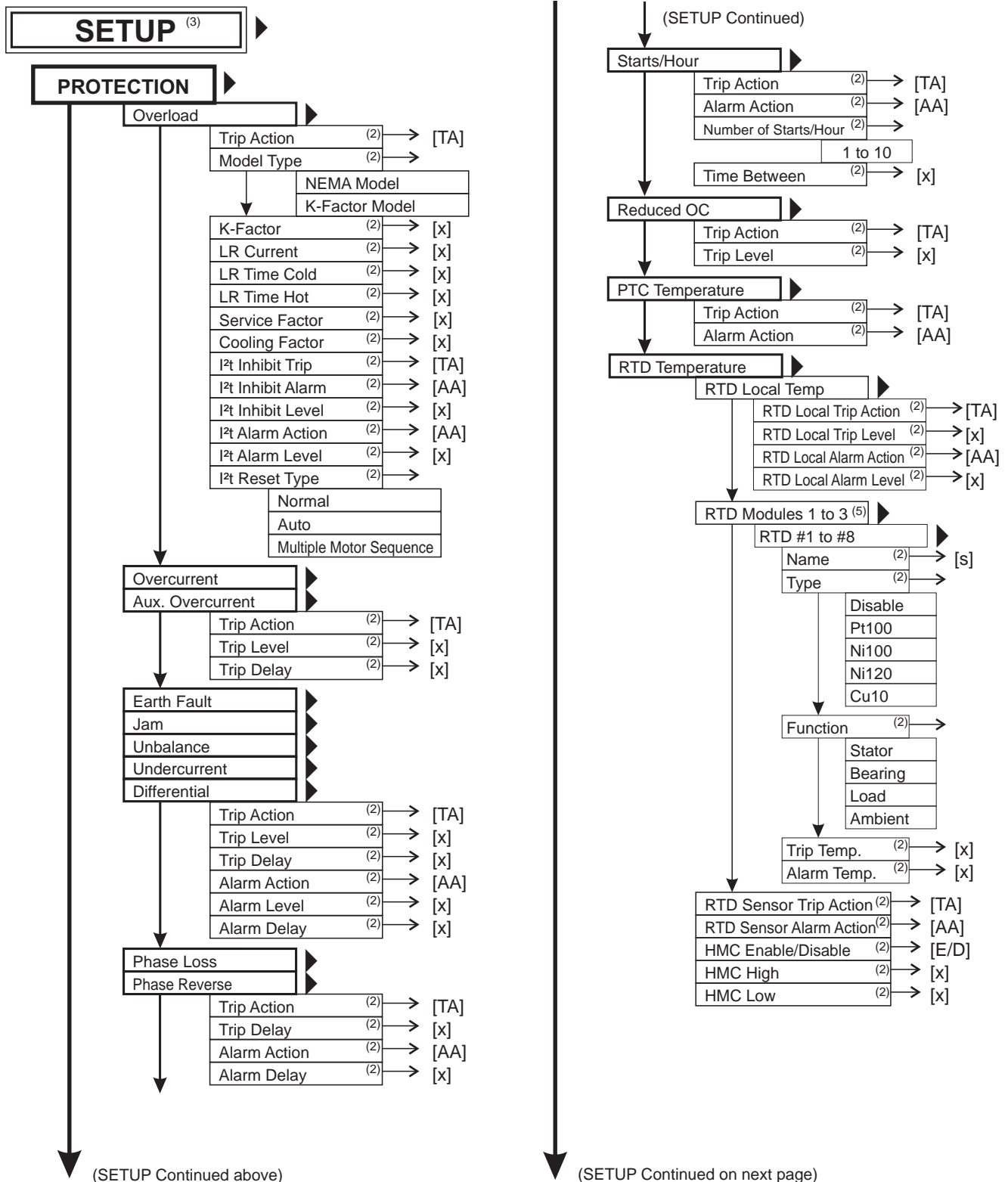

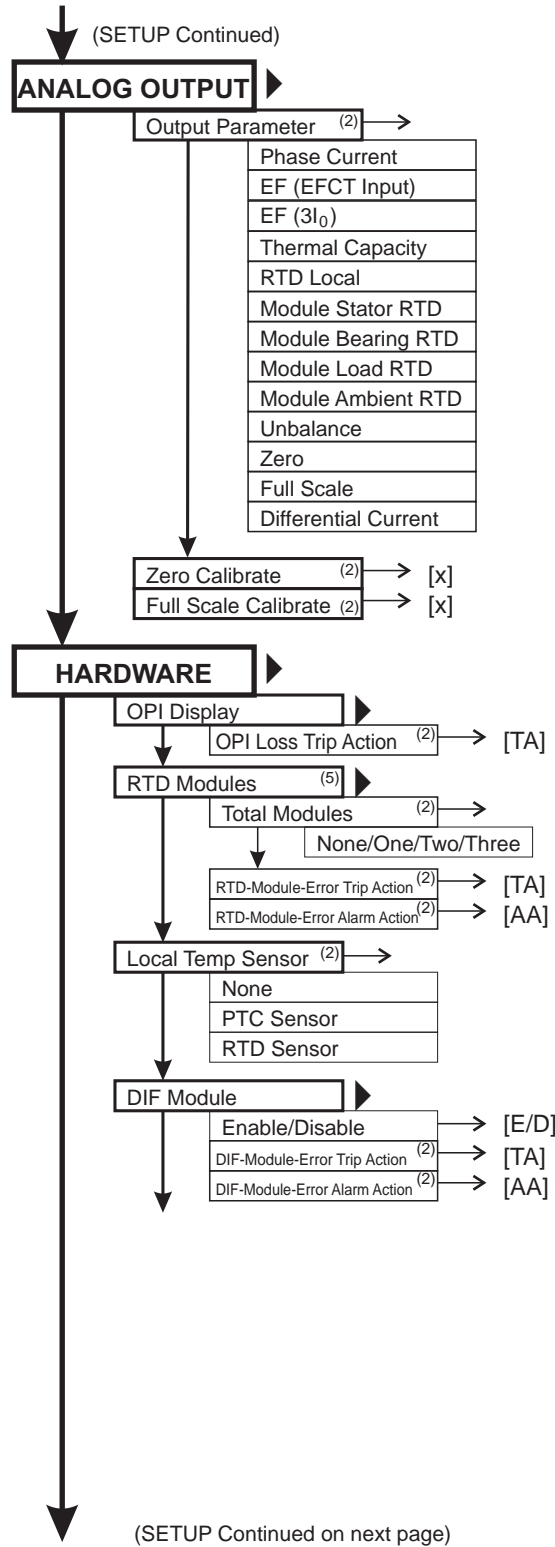
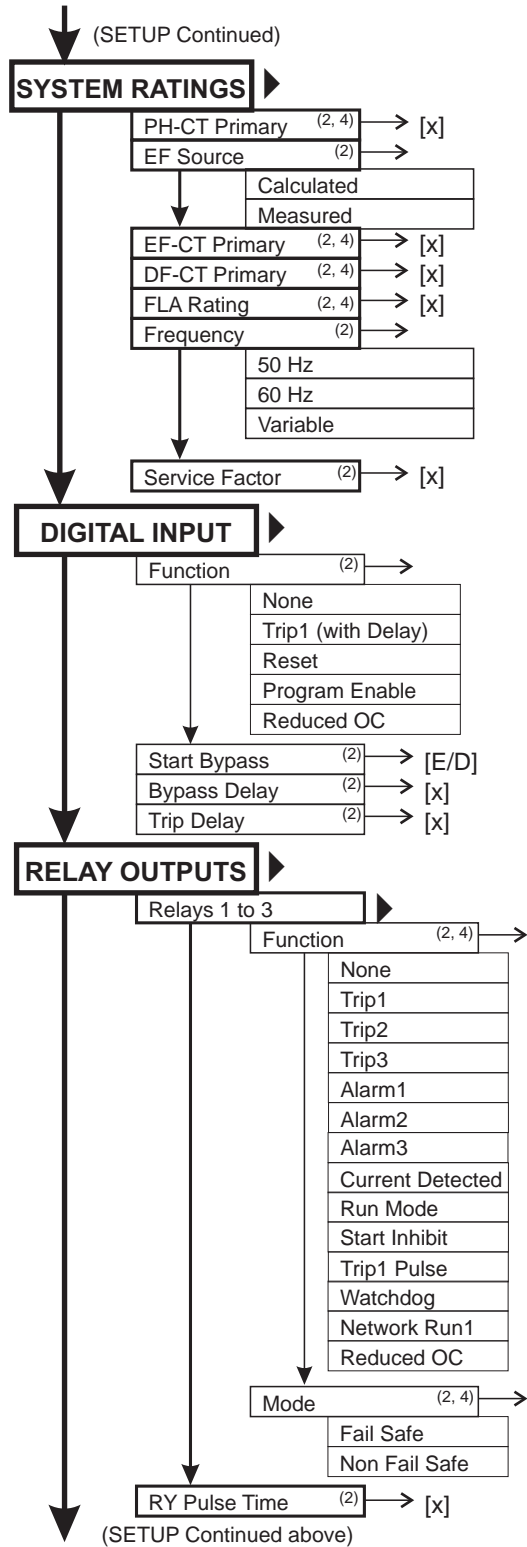

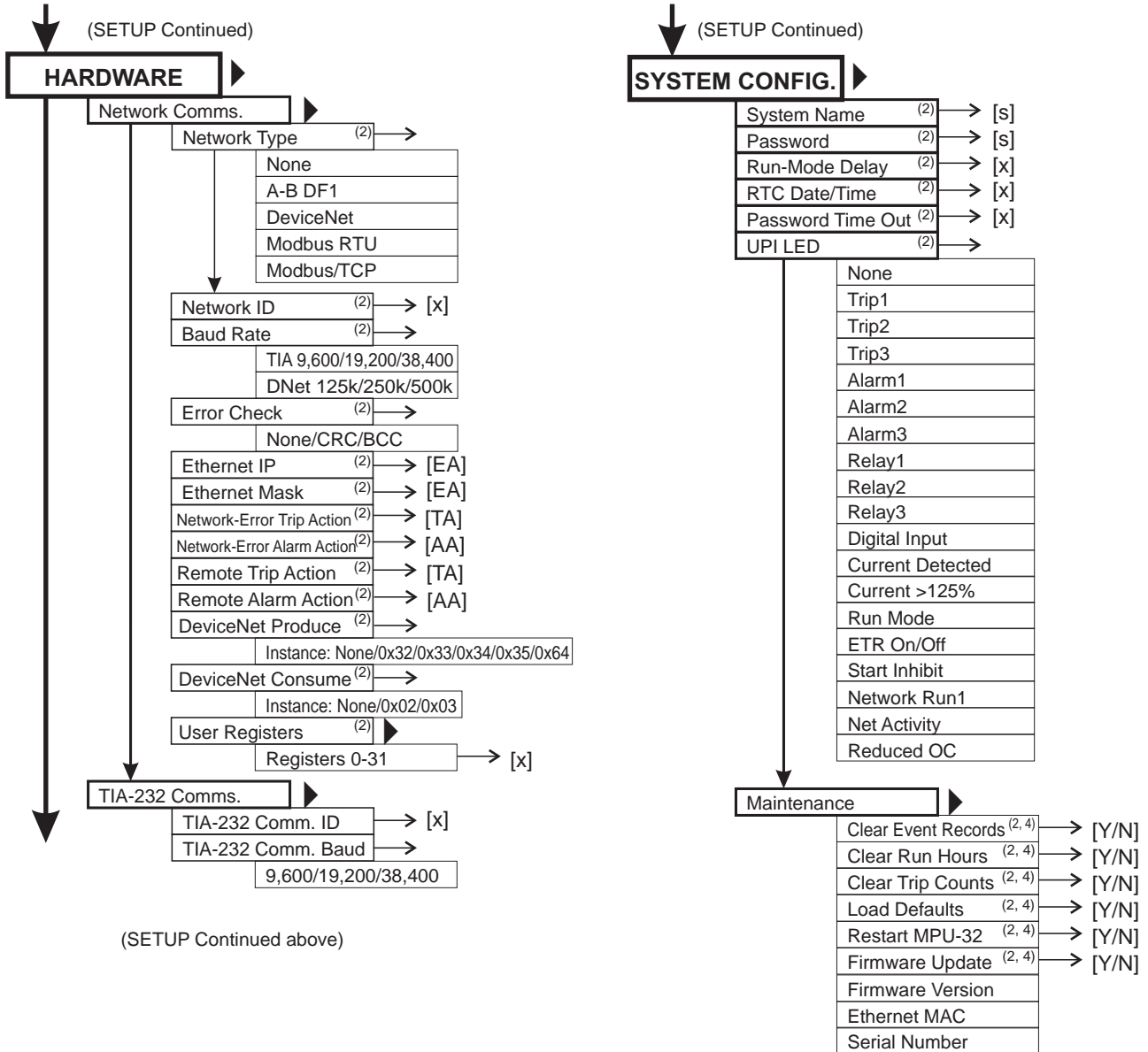

This page intentionally left blank

**APPENDIX B
 PGR-6200 SETUP RECORD**

Motor: _____ PGR-6200 S/N: _____ Date: _____

Firmware Revision: _____ Ethernet MAC ID: _____

PART I: SYSTEM AND MOTOR PARAMETERS

PARAMETER AND SETTINGS	MIN	DEFAULT	MAX	UNIT	PROGRAM SELECTION
System Ratings					
PH-CT Primary (I_p) ⁽¹⁾	1	100.00	5,000	A	
EF Source		Measured (Ict)			<input type="checkbox"/> Calculated ($3I_0$) <input type="checkbox"/> Measured (Ict)
EF-CT Primary (I_e) ⁽¹⁾	1	5.00	5,000	A	
DF-CT Primary (I_d)	1	100.00	5,000	A	
Full-Load Current ⁽¹⁾	1	100.00	5,000	A	
Service Factor	1	1.00	1.25		
Frequency		60		Hz	<input type="checkbox"/> 50 <input type="checkbox"/> Variable <input type="checkbox"/> 60
Digital Input					
Function		None			<input type="checkbox"/> None <input type="checkbox"/> Reset <input type="checkbox"/> Trip1 <input type="checkbox"/> Program Enable <input type="checkbox"/> Reduced OC
Start Bypass		Disabled			<input type="checkbox"/> Enabled <input type="checkbox"/> Disabled
Bypass Delay	0.5	5.00	100	s	
Trip Delay	0.01	0.10	100	s	
Relay Outputs See Table 4.2 Output-Relay Functions					
Relay 1: Function ⁽¹⁾		Trip1			
Mode ⁽¹⁾		Fail Safe			<input type="checkbox"/> Fail Safe <input type="checkbox"/> Non-Fail Safe
Relay 2: Function ⁽¹⁾		Alarm1			
Mode ⁽¹⁾		Fail Safe			<input type="checkbox"/> Fail Safe <input type="checkbox"/> Non-Fail Safe
Relay 3: Function ⁽¹⁾		None			
Mode ⁽¹⁾		Fail Safe			<input type="checkbox"/> Fail Safe <input type="checkbox"/> Non-Fail Safe
RY Pulse Time	0.05	0.25	10	s	
Analog Output See Table 4.4 Analog-Output Parameters					
Output Parameter		Phase Current			
Zero Calibrate		Factory Calibrated			
Full-Scale Calibrate		Factory Calibrated			
HARDWARE					
OPI Display					
OPI-Loss Trip		Trip1			<input type="checkbox"/> Disabled <input type="checkbox"/> Trip1 <input type="checkbox"/> Trip2 <input type="checkbox"/> Trip3
RTD Modules (PGA-0120)					
Total Modules		0			<input type="checkbox"/> 0 <input type="checkbox"/> 2 <input type="checkbox"/> 1 <input type="checkbox"/> 3
RTD-Module-Error Trip Action		Disabled			<input type="checkbox"/> Disabled <input type="checkbox"/> Trip1 <input type="checkbox"/> Trip2 <input type="checkbox"/> Trip3
RTD-Module-Error Alarm Action		Alarm1			<input type="checkbox"/> Disabled <input type="checkbox"/> Alarm1 <input type="checkbox"/> Alarm2 <input type="checkbox"/> Alarm3

PARAMETER AND SETTINGS	MIN	DEFAULT	MAX	UNIT	PROGRAM SELECTION	
PGR-6200 Temperature Sensor		Disabled			<input type="checkbox"/> Disabled <input type="checkbox"/> RTD Sensor	<input type="checkbox"/> PTC Sensor
DIF Module						
Enable/Disable		Disabled			<input type="checkbox"/> Enabled <input type="checkbox"/> Disabled	<input type="checkbox"/> Disabled
DIF-Module-Error Trip Action		Disabled			<input type="checkbox"/> Disabled <input type="checkbox"/> Trip2	<input type="checkbox"/> Trip1 <input type="checkbox"/> Trip3
DIF-Module-Error Alarm Action		Disabled			<input type="checkbox"/> Disabled <input type="checkbox"/> Alarm2	<input type="checkbox"/> Alarm1 <input type="checkbox"/> Alarm3
TIA-232 Communications						
TIA-232 Comm ID	0	254	255			
TIA-232 Comm Baud		9,600		bit/s	<input type="checkbox"/> 9,600 <input type="checkbox"/> 19,200	<input type="checkbox"/> 38,400
Network Communications						
Network Type		None			<input type="checkbox"/> None <input type="checkbox"/> A-B DF1 <input type="checkbox"/> Modbus RTU	<input type="checkbox"/> Modbus TCP <input type="checkbox"/> DeviceNet
Network ID	0	254	255			
Baud Rate		TIA 9600			<input type="checkbox"/> TIA 9600 <input type="checkbox"/> TIA 19k2 <input type="checkbox"/> TIA 38k4	<input type="checkbox"/> DN125 <input type="checkbox"/> DN250 <input type="checkbox"/> DN500
Error Checking (A-B DF1 Only)		Not Selected			<input type="checkbox"/> Not Selected <input type="checkbox"/> CRC	<input type="checkbox"/> BCC
Ethernet IP		192.168. 000.001				
Ethernet Mask		255.255. 255.000				
Network-Error Trip Action		Disabled			<input type="checkbox"/> Disabled <input type="checkbox"/> Trip2	<input type="checkbox"/> Trip1 <input type="checkbox"/> Trip3
Network-Error Alarm Action		Disabled			<input type="checkbox"/> Disabled <input type="checkbox"/> Alarm2	<input type="checkbox"/> Alarm1 <input type="checkbox"/> Alarm3
Remote Trip Action		Disabled			<input type="checkbox"/> Disabled <input type="checkbox"/> Trip2	<input type="checkbox"/> Trip1 <input type="checkbox"/> Trip3
Remote Alarm Action		Disabled			<input type="checkbox"/> Disabled <input type="checkbox"/> Alarm2	<input type="checkbox"/> Alarm1 <input type="checkbox"/> Alarm3
DeviceNet Producing Assembly		0 x 64			<input type="checkbox"/> 0 x 32 <input type="checkbox"/> 0 x 33 <input type="checkbox"/> 0 x 34	<input type="checkbox"/> 0 x 35 <input type="checkbox"/> 0 x 64
DeviceNet Consuming Assembly		0 x 03			<input type="checkbox"/> 0 x 02	<input type="checkbox"/> 0 x 03
User Registers						
User Register 0	0	0	1399			
User Register 1	0	0	1399			
User Register 2	0	0	1399			
User Register 3	0	0	1399			
User Register 4	0	0	1399			
User Register 5	0	0	1399			
User Register 6	0	0	1399			
User Register 7	0	0	1399			
User Register 8	0	0	1399			
User Register 9	0	0	1399			
User Register 10	0	0	1399			

PARAMETER AND SETTINGS	MIN	DEFAULT	MAX	UNIT	PROGRAM SELECTION
User Register 11	0	0	1399		
User Register 12	0	0	1399		
User Register 13	0	0	1399		
User Register 14	0	0	1399		
User Register 15	0	0	1399		
User Register 16	0	0	1399		
User Register 17	0	0	1399		
User Register 18	0	0	1399		
User Register 19	0	0	1399		
User Register 20	0	0	1399		
User Register 21	0	0	1399		
User Register 22	0	0	1399		
User Register 23	0	0	1399		
User Register 24	0	0	1399		
User Register 25	0	0	1399		
User Register 26	0	0	1399		
User Register 27	0	0	1399		
User Register 28	0	0	1399		
User Register 29	0	0	1399		
User Register 30	0	0	1399		
User Register 31	0	0	1399		
SYSTEM CONFIG					
System Name	POWR-GARD PGR-6200				
Password		1111			
Run-Mode Delay	5	10.00	60	s	
Password Timeout	1	10.00	60	min	
UPI LED		None	See Table 4.1 UPI LED Functions		

PART II: PROTECTION SET POINTS

FUNCTION & SET POINT	MIN	DEFAULT	MAX	UNIT	PROGRAM SELECTION
Overload					
I ² t Trip Action		Trip1			<input type="checkbox"/> Disabled <input type="checkbox"/> Trip1 <input type="checkbox"/> Trip2 <input type="checkbox"/> Trip3
I ² t Model Type		NEMA			<input type="checkbox"/> NEMA <input type="checkbox"/> K-Factor
K-Factor	1	6.00	10		
Locked-Rotor Current	1.5	6.00	10	x FLA	
Locked-Rotor Time Cold	0.10	10.00	100	s	
Locked-Rotor Time Hot	0.10	5.00	100	s	
Service Factor	1	1.00	1.25		
Cooling Factor	0.10	2.00	10		
I ² t Inhibit Trip		Disabled			<input type="checkbox"/> Disabled <input type="checkbox"/> Trip1 <input type="checkbox"/> Trip2 <input type="checkbox"/> Trip3
I ² t Inhibit Alarm		Disabled			<input type="checkbox"/> Disabled <input type="checkbox"/> Alarm1 <input type="checkbox"/> Alarm2 <input type="checkbox"/> Alarm3
I ² t Inhibit Level (Per unit based on 100% I ² t)	0.10	0.30	0.90	pu	
I ² t Alarm Action		Alarm1			<input type="checkbox"/> Disabled <input type="checkbox"/> Alarm1 <input type="checkbox"/> Alarm2 <input type="checkbox"/> Alarm3

FUNCTION & SET POINT	MIN	DEFAULT	MAX	UNIT	PROGRAM SELECTION
I ² t Alarm Level (Per unit based on 100% I ² t)	0.50	1.00	1	pu	
I ² t Reset Type		Normal			<input type="checkbox"/> Normal <input type="checkbox"/> Auto <input type="checkbox"/> Multiple Motor Sequence
Overcurrent					
Trip Action		Trip1			<input type="checkbox"/> Disabled <input type="checkbox"/> Trip1 <input type="checkbox"/> Trip2 <input type="checkbox"/> Trip3
Trip Level (I _p is Phase-CT-primary rating)	1	10.00	15	x I _p	
Trip Delay	0	0.05	10	s	
Auxiliary Overcurrent					
Trip Action		Disabled			<input type="checkbox"/> Disabled <input type="checkbox"/> Trip1 <input type="checkbox"/> Trip2 <input type="checkbox"/> Trip3
Trip Level (I _p is Phase-CT-primary rating)	1	10.00	15	x I _p	
Trip Delay	0	0.05	10	s	
Reduced Overcurrent ⁽⁴⁾					
Trip Action		Trip1			<input type="checkbox"/> Disabled <input type="checkbox"/> Trip1 <input type="checkbox"/> Trip2 <input type="checkbox"/> Trip3
Trip Level (I _p is Phase-CT-primary rating)	1	2.00	15	x I _p	
Earth Fault					
Trip Action		Trip1			<input type="checkbox"/> Disabled <input type="checkbox"/> Trip1 <input type="checkbox"/> Trip2 <input type="checkbox"/> Trip3
Trip Level (I _e is EF-CT-primary rating)	0.01	0.40	1	x I _e	
Trip Delay	0	0.25	100	s	
Alarm Action		Alarm1			<input type="checkbox"/> Disabled <input type="checkbox"/> Alarm1 <input type="checkbox"/> Alarm2 <input type="checkbox"/> Alarm3
Alarm Level	0.01	0.20	1	x I _e	
Alarm Delay	0	1.00	100	s	
Jam					
Trip Action		Trip1			<input type="checkbox"/> Disabled <input type="checkbox"/> Trip1 <input type="checkbox"/> Trip2 <input type="checkbox"/> Trip3
Trip Level	1	6.00	10	x FLA	
Trip Delay	1	5.00	100	s	
Alarm Action		Alarm1			<input type="checkbox"/> Disabled <input type="checkbox"/> Alarm1 <input type="checkbox"/> Alarm2 <input type="checkbox"/> Alarm3
Alarm Level	1	3.00	10	x FLA	
Alarm Delay	1	5.00	100	s	
Unbalance					
Trip Action		Trip1			<input type="checkbox"/> Disabled <input type="checkbox"/> Trip1 <input type="checkbox"/> Trip2 <input type="checkbox"/> Trip3
Trip Level (Per unit based on I ₂ /I ₁)	0.05	0.25	1	pu	
Trip Delay	1	15.00	100	s	
Alarm Action		Alarm1			<input type="checkbox"/> Disabled <input type="checkbox"/> Alarm1 <input type="checkbox"/> Alarm2 <input type="checkbox"/> Alarm3
Alarm Level (Per unit based on I ₂ /I ₁)	0.05	0.10	1	pu	
Alarm Delay	1	10.00	100	s	

FUNCTION & SET POINT	MIN	DEFAULT	MAX	UNIT	PROGRAM SELECTION
Phase Loss					
Trip Action		Disabled			<input type="checkbox"/> Disabled <input type="checkbox"/> Trip1 <input type="checkbox"/> Trip2 <input type="checkbox"/> Trip3
Trip Delay	1	5.00	100	s	
Alarm Action		Disabled			<input type="checkbox"/> Disabled <input type="checkbox"/> Alarm1 <input type="checkbox"/> Alarm2 <input type="checkbox"/> Alarm3
Alarm Delay	1	2.00	100	s	
Phase Reverse					
Trip Action		Disabled			<input type="checkbox"/> Disabled <input type="checkbox"/> Trip1 <input type="checkbox"/> Trip2 <input type="checkbox"/> Trip3
Trip Delay	1	5.00	100	s	
Alarm Action		Disabled			<input type="checkbox"/> Disabled <input type="checkbox"/> Alarm1 <input type="checkbox"/> Alarm2 <input type="checkbox"/> Alarm3
Alarm Delay	1	2.00	100	s	
Undercurrent					
Trip Action		Disabled			<input type="checkbox"/> Disabled <input type="checkbox"/> Trip1 <input type="checkbox"/> Trip2 <input type="checkbox"/> Trip3
Trip Level	0.1	0.50	1	x FLA	
Trip Delay	1	10.00	100	s	
Alarm Action		Disabled			<input type="checkbox"/> Disabled <input type="checkbox"/> Alarm1 <input type="checkbox"/> Alarm2 <input type="checkbox"/> Alarm3
Alarm Level	0.1	0.80	1	x FLA	
Alarm Delay	1	20.00	100	s	
Differential					
Trip Action		Disabled			<input type="checkbox"/> Disabled <input type="checkbox"/> Trip1 <input type="checkbox"/> Trip2 <input type="checkbox"/> Trip3
Trip Level (I_d is DF-CT-Primary Current)	0.1	1.00	15	x I_d	
Trip Delay	0	0.10	10	s	
Alarm Action		Disabled			<input type="checkbox"/> Disabled <input type="checkbox"/> Alarm1 <input type="checkbox"/> Alarm2 <input type="checkbox"/> Alarm3
Alarm Level	0.1	0.50	15	x I_d	
Alarm Delay	0	0.10	10	s	
Starts/Hour					
Trip Action		Disabled			<input type="checkbox"/> Disabled <input type="checkbox"/> Trip1 <input type="checkbox"/> Trip2 <input type="checkbox"/> Trip3
Alarm Action		Disabled			<input type="checkbox"/> Disabled <input type="checkbox"/> Alarm1 <input type="checkbox"/> Alarm2 <input type="checkbox"/> Alarm3
Number of Starts/Hour	1	5	10		
Time Between Starts	0	0.00	500	min	
PTC Temperature					
Trip Action		Disabled			<input type="checkbox"/> Disabled <input type="checkbox"/> Trip1 <input type="checkbox"/> Trip2 <input type="checkbox"/> Trip3
Alarm Action		Disabled			<input type="checkbox"/> Disabled <input type="checkbox"/> Alarm1 <input type="checkbox"/> Alarm2 <input type="checkbox"/> Alarm3
RTD Temperature (Local)					
Trip Action		Disabled			<input type="checkbox"/> Disabled <input type="checkbox"/> Trip1 <input type="checkbox"/> Trip2 <input type="checkbox"/> Trip3
Trip Level	40	130.00	200	°C	
Alarm Action		Disabled			<input type="checkbox"/> Disabled <input type="checkbox"/> Alarm1 <input type="checkbox"/> Alarm2 <input type="checkbox"/> Alarm3
Alarm Level	40	130.00	200	°C	

FUNCTION & SET POINT	MIN	DEFAULT	MAX	UNIT	PROGRAM SELECTION
RTD Temperature (PGA-0120 Module) ⁽²⁾					
RTD M1 #1:					
Name	RTD Module 1 #1				
Type		Disabled			<input type="checkbox"/> Disabled <input type="checkbox"/> Ni120 <input type="checkbox"/> Pt100 <input type="checkbox"/> Cu10 <input type="checkbox"/> Ni100
Function		Stator			<input type="checkbox"/> Stator <input type="checkbox"/> Load <input type="checkbox"/> Bearing <input type="checkbox"/> Ambient
Trip	40	130.00	200	°C	
Alarm	40	110.00	200	°C	
RTD M1 #2:					
Name	RTD Module 1 #2				
Type		Disabled			<input type="checkbox"/> Disabled <input type="checkbox"/> Ni120 <input type="checkbox"/> Pt100 <input type="checkbox"/> Cu10 <input type="checkbox"/> Ni100
Function		Stator			<input type="checkbox"/> Stator <input type="checkbox"/> Load <input type="checkbox"/> Bearing <input type="checkbox"/> Ambient
Trip	40	130.00	200	°C	
Alarm	40	110.00	200	°C	
RTD M1 #3:					
Name	RTD Module 1 #3				
Type		Disabled			<input type="checkbox"/> Disabled <input type="checkbox"/> Ni120 <input type="checkbox"/> Pt100 <input type="checkbox"/> Cu10 <input type="checkbox"/> Ni100
Function		Stator			<input type="checkbox"/> Stator <input type="checkbox"/> Load <input type="checkbox"/> Bearing <input type="checkbox"/> Ambient
Trip	40	130.00	200	°C	
Alarm	40	110.00	200	°C	
RTD M1 #4:					
Name	RTD Module 1 #4				
Type		Disabled			<input type="checkbox"/> Disabled <input type="checkbox"/> Ni120 <input type="checkbox"/> Pt100 <input type="checkbox"/> Cu10 <input type="checkbox"/> Ni100
Function		Stator			<input type="checkbox"/> Stator <input type="checkbox"/> Load <input type="checkbox"/> Bearing <input type="checkbox"/> Ambient
Trip	40	130.00	200	°C	
Alarm	40	110.00	200	°C	
RTD M1 #5:					
Name	RTD Module 1 #5				
Type		Disabled			<input type="checkbox"/> Disabled <input type="checkbox"/> Ni120 <input type="checkbox"/> Pt100 <input type="checkbox"/> Cu10 <input type="checkbox"/> Ni100
Function		Stator			<input type="checkbox"/> Stator <input type="checkbox"/> Load <input type="checkbox"/> Bearing <input type="checkbox"/> Ambient
Trip	40	130.00	200	°C	
Alarm	40	110.00	200	°C	
RTD M1 #6:					
Name	RTD Module 1 #6				
Type		Disabled			<input type="checkbox"/> Disabled <input type="checkbox"/> Ni120 <input type="checkbox"/> Pt100 <input type="checkbox"/> Cu10 <input type="checkbox"/> Ni100
Function		Stator			<input type="checkbox"/> Stator <input type="checkbox"/> Load <input type="checkbox"/> Bearing <input type="checkbox"/> Ambient
Trip	40	130.00	200	°C	
Alarm	40	110.00	200	°C	

FUNCTION & SET POINT	MIN	DEFAULT	MAX	UNIT	PROGRAM SELECTION
RTD M1 #7:					
Name	RTD Module 1 #7			Name	RTD Module 1 #7
Type		Type		Type	
Function		Function		Function	
Trip	40	Trip	40	Trip	40
Alarm	40	Alarm	40	Alarm	40
RTD M1 #8:					
Name	RTD Module 1 #8			Name	RTD Module 1 #8
Type		Type		Type	
Function		Function		Function	
Trip	40	Trip	40	Trip	40
Alarm	40	Alarm	40	Alarm	40
RTD M2 #1:					
Name	RTD Module 2 #1			Name	RTD Module 2 #1
Type		Type		Type	
Function		Function		Function	
Trip	40	Trip	40	Trip	40
Alarm	40	Alarm	40	Alarm	40
RTD M2 #2:					
Name	RTD Module 2 #2			Name	RTD Module 2 #2
Type		Type		Type	
Function		Function		Function	
Trip	40	Trip	40	Trip	40
Alarm	40	Alarm	40	Alarm	40
RTD M2 #3:					
Name	RTD Module 2 #3			Name	RTD Module 2 #3
Type		Type		Type	
Function		Function		Function	
Trip	40	Trip	40	Trip	40
Alarm	40	Alarm	40	Alarm	40
RTD M2 #4:					
Name	RTD Module 2 #4			Name	RTD Module 2 #4
Type		Type		Type	
Function		Function		Function	
Trip	40	Trip	40	Trip	40
Alarm	40	Alarm	40	Alarm	40
RTD M2 #5:					
Name	RTD Module 2 #5			Name	RTD Module 2 #5
Type		Type		Type	
Function		Function		Function	
Trip	40	Trip	40	Trip	40
Alarm	40	Alarm	40	Alarm	40
RTD M2 #6:					
Name	RTD Module 2 #6			Name	RTD Module 2 #6
Type		Type		Type	
Function		Function		Function	
Trip	40	Trip	40	Trip	40
Alarm	40	Alarm	40	Alarm	40

FUNCTION & SET POINT	MIN	DEFAULT	MAX	UNIT	PROGRAM SELECTION
RTD M2 #7:					
Name	RTD Module 2 #7			Name	RTD Module 2 #7
Type		-Type		-Type	
Function		Function		Function	
Trip	40	Trip	40	Trip	40
Alarm	40	Alarm	40	Alarm	40
RTD M2 #8:					
Name	RTD Module 2 #8			Name	RTD Module 2 #8
Type		Type		Type	
Function		Function		Function	
Trip	40	Trip	40	Trip	40
Alarm	40	Alarm	40	Alarm	40
RTD M3 #1:					
Name	RTD Module 3 #1			Name	RTD Module 3 #1
Type		Type		Type	
Function		Function		Function	
Trip	40	Trip	40	Trip	40
Alarm	40	Alarm	40	Alarm	40
RTD M3 #2:					
Name	RTD Module 3 #2			Name	RTD Module 3 #2
Type		Type		Type	
Function		Function		Function	
Trip	40	Trip	40	Trip	40
Alarm	40	Alarm	40	Alarm	40
RTD M3 #3:					
Name	RTD Module 3 #3			Name	RTD Module 3 #3
Type		Type		Type	
Function		Function		Function	
Trip	40	Trip	40	Trip	40
Alarm	40	Alarm	40	Alarm	40
RTD M3 #4:					
Name	RTD Module 3 #4			Name	RTD Module 3 #4
Type		Type		Type	
Function		Function		Function	
Trip	40	Trip	40	Trip	40
Alarm	40	Alarm	40	Alarm	40
RTD M3 #5:					
Name	RTD Module 3 #5			Name	RTD Module 3 #5
Type		Type		Type	
Function		Function		Function	
Trip	40	Trip	40	Trip	40
Alarm	40	Alarm	40	Alarm	40
RTD M3 #6:					
Name	RTD Module 3 #6			Name	RTD Module 3 #6
Type		Type		Type	
Function		Function		Function	
Trip	40	Trip	40	Trip	40
Alarm	40	Alarm	40	Alarm	40

FUNCTION & SET POINT	MIN	DEFAULT	MAX	UNIT	PROGRAM SELECTION	
RTD M3 #7:						
Name	RTD Module 3 #7		Name	RTD Module 3 #7	Name	
Type		Type		Type	Type	
Function		Function		Function	Function	
Trip	40	Trip	40	Trip	40	Trip
Alarm	40	Alarm	40	Alarm	40	Alarm
RTD M3 #8:						
Name	RTD Module 3 #8		Name	RTD Module 3 #8	Name	
Type		Type		Type	Type	
Function		Function		Function	Function	
Trip	40	Trip	40	Trip	40	Trip
Alarm	40	Alarm	40	Alarm	40	Alarm
RTD-Sensor-Error Trip Action ⁽³⁾		Disabled			<input type="checkbox"/> Disabled <input type="checkbox"/> Trip2	<input type="checkbox"/> Trip1 <input type="checkbox"/> Trip3
RTD-Sensor-Error Alarm Action ⁽³⁾		Alarm1			<input type="checkbox"/> Disabled <input type="checkbox"/> Alarm2	<input type="checkbox"/> Alarm1 <input type="checkbox"/> Alarm3
Hot-Motor Compensation (HMC) ⁽³⁾		Disabled			<input type="checkbox"/> Enabled	<input type="checkbox"/> Disabled
<i>HMC High</i> ⁽³⁾	40	150.00	200	°C		
<i>HMC Low</i> ⁽³⁾	40	40.00	200	°C		
RTD-Sensor-Error Trip Action ⁽³⁾		Disabled			<input type="checkbox"/> Disabled <input type="checkbox"/> Trip2	<input type="checkbox"/> Trip1 <input type="checkbox"/> Trip3
RTD-Sensor-Error Alarm Action ⁽³⁾		Alarm1			<input type="checkbox"/> Disabled <input type="checkbox"/> Alarm2	<input type="checkbox"/> Alarm1 <input type="checkbox"/> Alarm3
Hot-Motor Compensation (HMC) ⁽³⁾		Disabled			<input type="checkbox"/> Enabled	<input type="checkbox"/> Disabled
<i>HMC High</i> ⁽³⁾	40	150.00	200	°C		
<i>HMC Low</i> ⁽³⁾	40	40.00	200	°C		

⁽¹⁾ Locked when the motor is running

⁽²⁾ PGA-0120 Module temperature actions are fixed as *Trip1* and *Alarm1*.

⁽³⁾ Applies to both local and module RTD's.

⁽⁴⁾ Requires Digital Input set to *Reduced OC* for operation.

APPENDIX C
NOT USED

APPENDIX D PGR-6200 TIA-232 MODBUS PROTOCOL

D.1 PROTOCOL

The PGR-6200 implements the Modbus® RTU protocol as described in the Gould Modbus Reference Guide, Publication PI-MBUS-300 Rev. B.

Only the master can initiate a message transaction. Messages can be addressed to individual slaves or they can be broadcast messages. Broadcast messages are executed on the slaves but unlike individually addressed messages, the slaves do not generate a reply message.

Modicon Modbus® is a registered trademark of Schneider Electric.

D.1.1 Protocol Setup

Setup options are available in the *Setup | Hardware | Local Comms* menu. Select *Local Comm ID* and *Local Comm Baud*.

D.2 MESSAGE SYNCHRONIZATION

Message synchronization is accomplished by detection of an idle communication line. The communication line is considered idle when no communication exists for an equivalent delay of 3.5 characters.

The first byte received after idle-line detection is interpreted as the address byte of the next message. Message bytes must be transmitted in a continuous stream until the complete message has been sent. If a delay of more than 3.5 characters exists within the message, the message is discarded.

Response messages from the PGR-6200 are delayed by at least 3.5 character delays.

D.3 ERROR CHECKING

Modbus RTU uses a 16-bit cyclic redundancy check (CRC). The error check includes all of the message bytes, starting with the first address byte.

When a CRC error is detected, the message is discarded and there will be no response.

If the CRC check is correct but the internal data in the message is not correct, the PGR-6200 will respond with an exception response code.

D.4 FUNCTION CODES SUPPORTED

The PGR-6200 Modbus Protocol supports the following function codes:

- Read Holding Registers (Function Code 3)
- Read Input Registers (Function Code 4)
- Write Single Register (Function Code 6)
- Write Multiple Registers (Function Code 16)
- Command Instruction (Function Code 5)

Function Codes 3 and 4 perform the same function in the PGR-6200.

Registers in Modbus start at 40001 decimal and the register address generated for this register is 0.

D.4.1 Application Layer

The hexadecimal system is used. Value representations use the “C” convention. For hexadecimal, 0x precedes the value.

D.4.2 Read Input/Holding Registers (Code 04/03)

The first byte of the read message is the slave address. The second byte is the function code. Bytes three and four indicate the starting register. The next two bytes specify the number of 16-bit registers to read. The last two bytes contain the CRC code for the message.

TABLE D.1 Read Registers (Code 04/03)

HEX BYTE	DESCRIPTION
Byte 1	Slave Address
Byte 2	Function Code
Byte 3	MSB Register Address
Byte 4	LSB Register Address
Byte 5	MSB Number of Registers
Byte 6	LSB Number of Registers
Byte 7	LSB CRC
Byte 8	MSB CRC

The two-byte values of starting register and number of registers to read are transmitted with the high-order byte followed by the low-order byte.

The CRC value is sent with the LSB followed by the MSB.

The following message will obtain the value of register 1 (Modbus 40002) from slave 1. Note that Modbus registers are numbered from zero (40001 = zero, 40002 = one, etc.):

0x01 | 0x03 | 0x00 | 0x01 | 0x00 | 0x01 | 0xD5 | 0xCA

The addressed slave responds with its address and Function Code 3, followed by the information field. The information field contains an 8-bit byte count and the 16-bit data from the slave. The byte count specifies the number of bytes of data in the information field. The data in the information field

consists of 16-bit data arranged so that the MSB is followed by the LSB.

D.4.3 Write to Register

Function Code 6 or 16 is used to make set-point changes.

D.4.3.1 Write Single Register (Code 6)

The function code format for writing a single register is shown in Table D.2.

The message consists of the slave address followed by the Function Code 6 and two 16-bit values. The first 16-bit value specifies the register to be modified and the second value is the 16-bit data.

Provided no errors occurred, the slave will re-send the original message to the master. The response message is returned only after the command has been executed by the slave.

The following message will set register 3 to 300 in slave 5:

0x05 | 0x06 | 0x00 | 0x03 | 0x01 | 0x2C | 0x78 | 0x03

TABLE D.2 Write Single Register (Code 6)

HEX BYTE	DESCRIPTION
Byte 1	Slave Address
Byte 2	Function Code
Byte 3	MSB Register Address
Byte 4	LSB Register Address
Byte 5	MSB of Data
Byte 6	LSB of Data
Byte 7	LSB of CRC
Byte 8	MSB of CRC

D.4.3.2 Write Multiple Registers (Code 16)

The function-code format in Table D.3 can be used for writing single or multiple registers.

TABLE D.3 Write Multiple Registers (Code 16)

BYTE #	DESCRIPTION
Byte 1	Slave Address
Byte 2	Function Code
Byte 3	MSB Register Address
Byte 4	LSB Register Address
Byte 5	MSB of Quantity
Byte 6	LSB of Quantity
Byte 7	Byte Count
.	MSB of Data
.	LSB of Data
.	LSB of CRC
Byte n	MSB of CRC

The slave will reply with the slave address, function code, register address, and the quantity followed by the CRC code for a total of 8 bytes.

D.4.4 Command Instruction (Code 5)

Modbus Function Code 5 (Force Single Coil) is used to issue commands to the PGR-6200. The format for the message is listed in Table D.4 and the command code actions and corresponding coil number are listed in Table D.5.

TABLE D.4 Command Format (Code 5)

HEX BYTE	DESCRIPTION
Byte 1	Slave Address
Byte 2	Function Code
Byte 3	MSB of Command Code
Byte 4	LSB of Command Code
Byte 5	Fixed at 0xFF
Byte 6	Fixed at 00
Byte 7	LSB of CRC
Byte 8	MSB of CRC

TABLE D.5 Supported Commands

COMMAND CODE	COIL NUMBER	ACTION
0x0003	4	Reset Trips
0x0004	5	Set Real-Time Clock
0x0005	6	Clear Data-Logging Records
0x0006	7	Clear Trip Counters
0x0008	9	Clear Running Hours
0x0009	10	Emergency I ² t and Trip
0x000C	13	Reset
0x000D	14	Re-enable Temperature
0x000E	15	Protection
0x000F	16	Remote/Net Trip Set
0x0010	17	Remote/Net Trip Clear
0x0011	18	Remote/Net Alarm Set
0x0012	19	Remote/Net Alarm Clear
		Run1 Set
		Run1 Clear

Except for a broadcast address, the slave will return the original packet to the master.

D.4.5 Command Instructions Using Write Commands

For PLC's not supporting Function Code 5, commands can be issued using Write Single Register (Code 6) and Write Multiple Register (Code 16).

Commands are written to PGR-6200 register 6 (Modbus register 40007). Supported commands are listed in the COMMAND CODE column in Table D.5.

When using the Write Multiple Registers function code, the write should be to the single PGR-6200 Register 6. If multiple registers are written starting at PGR-6200 Register 6, the first data element will be interpreted as the command code but no other registers will be written. If the command is successful, the PGR-6200 will return a valid response message.

D.4.6 Exception Responses

The PGR-6200 supports the following exception responses:

- Boundry Error (1)—Applies to writes of 32-bit values. The high-order word must be written first followed by the write to the low-order word. If this sequence is not followed, a Boundry Error is returned and the value will not be stored. This does not apply on read requests.
- Address Error (2)—All accesses to communication registers must be within the specified address range or the Address Error code is returned.
- Command Error (3)—This error code is returned if the command code is not supported.
- Illegal Function Code (4)—The function code (Byte 2) is not supported.

The exception message consists of the slave address followed by a retransmission of the original function code. The function code will have the most-significant bit set to indicate an error. The 8-bit byte following the function code is the exception response code. The 16-bit CRC is at the end of the message.

D.5 PGR-6200 DATABASE

Appendix E contains the Modbus Register in the Communications Database Table. The table starts at register 0 (Modbus 40001) and each register is 16-bits wide. Types "long" and "float" are 32-bit values. For both long and float types, the low-order word is transmitted first followed by the high-order word. Word values have the high byte followed by the low byte. Float types as per IEEE 754 Floating-Point Standard. All bytes of long and float types must be written using one message or an error will result. This does not apply for read commands.

D.5.1 Data Records

Only one event record can be read at a time. Record data is for the record indicated by the Record Selector. To select a record, write the record number to Record Selector and then read the values in the record. Record Head points to the next available record. The last event record captured is at Record Head minus one.

Both Record Selector and Record Head values are in the range of 0 to 99. Values outside this range will select record 0.

D.5.2 Custom Data Access

Data access can be customized with the User-Defined Registers and the User-Data Registers.

User-Defined Registers are located in non-volatile memory and contain the register numbers from which data is required. To access the data, read the corresponding User-Data Registers.

The format of the User Data is a function of the corresponding register entered in the User-Defined-Register area.

D.6 SPECIFICATIONS

Interface.....	Non-Isolated RS/EIA/TIA-232, RJ-45
Protocol.....	Modbus RTU
Baud Rate.....	9,600, 19,200, or 38,400 bit/s
Bit Format	8 bits, no parity, one stop bit

Note: A network communication interface has priority over the TIA-232 interface. To minimize TIA-232 errors when both network and TIA-232 communications are used, set the TIA-232 baud rate to 9,600 bit/s.

This page intentionally left blank.

APPENDIX E
COMMUNICATIONS DATABASE TABLE

PGR-6200 REGISTER (DECIMAL)	MODBUS REGISTER (DECIMAL)	DEVICENET (Hex) (NOTE 10)	A-B FILE (DECIMAL) (NOTE 4)	DESCRIPTION	ACCESS	RANGE	TYPE (NOTE 2)
Model Information							
0	40001	1-1-3	3:000	Model Code	Read Only		T3
1		1-1-64		Software Version	Read Only		T3
2		1-1-6		Serial Number	Read Only		T2 (low)
3							T2 (high)
4							
5							
6	N/A	29-1-64		Command Register	Write Only	0 – 18	T64
Overload							
8	40009	2C-1-64	3:8	I ² t Trip Action	R/W	0 – 7	T42
9		2C-1-65		I ² t Model Type	R/W	0 – 1	T33
10				Reserved			
11		2C-1-66		K-Factor	R/W	1 – 10	T1 (low)
12							T1 (high)
13		2C-1-67		Locked-Rotor Current	R/W	1.5 – 10 x FLA	T1 (low)
14							T1 (high)
15		2C-1-68		Locked-Rotor Time Cold	R/W	0.1 – 100 s	T1 (low)
16							T1 (high)
17		2C-1-69		Locked-Rotor Time Hot	R/W	0.1 – 100 s	T1 (low)
18							T1 (high)
19		2C-1-6A		Cooling Factor	R/W	0.1 – 10	T1 (low)
20							T1 (high)
21		2C-1-6B		I ² t Inhibit and Reset Level	R/W	0.1 – 0.9	T1 (low)
22							T1 (high)
23		2C-1-6C		I ² t Alarm Level	R/W	0.5 – 1.0	T1 (low)
24							T1 (high)
25		2C-1-6D		I ² t Alarm Action	R/W	0 – 7	T43
26		2C-1-6E		I ² t Inhibit Trip Action	R/W	0 – 7	T42
27		2C-1-6F		I ² t Inhibit Alarm Action	R/W	0 – 7	T43
28		2C-1-9D		I ² t Reset Type	R/W	0 – 2	T38
Overcurrent							
32	40033	64-01-01	3:32	Trip Action	R/W	0 – 7	T42
33		64-01-03		Trip Level	R/W	1 – 15 x I _p	T1 (low)
34							T1 (high)
35		64-01-04		Trip Delay	R/W	0 – 10 s	T1 (low)
36							T1 (high)
Aux Overcurrent							
40	40041	64-02-01	3:40	Trip Action	R/W	0 – 7	T42
41		64-02-03		Trip Level	R/W	1 – 15 x I _p	T1 (low)
42							T1 (high)
43		64-02-04		Trip Delay	R/W	0 – 10 s	T1 (low)
44							T1 (high)

PGR-6200 REGISTER (DECIMAL)	MODBUS REGISTER (DECIMAL)	DEVICENET (Hex) (NOTE 10)	A-B FILE (DECIMAL) (NOTE 4)	DESCRIPTION	ACCESS	RANGE	TYPE (NOTE 2)
Reduced Overcurrent							
45	40046	64-0B-01	3:45	Trip Action	R/W	0 – 7	T42
46		64-0B-03		Trip Level	R/W	1 – 15 x I _p	T1 (low)
47							T1 (high)
Earth Fault							
48	40049	64-03-01	3:48	Trip Action	R/W	0 – 7	T42
49				Spare			
50		64-03-03		Trip Level	R/W	0.01 – 1.0 x I _e	T1 (low)
51							T1 (high)
52		64-03-04		Trip Delay	R/W	0 – 100 s	T1 (low)
53							T1 (high)
54		64-03-05		Alarm Level	R/W	0.01 – 1.0 x I _e	T1 (low)
55							T1 (high)
56		64-03-06		Alarm Delay	R/W	0 – 100 s	T1 (low)
57							T1 (high)
58		64-03-02		Alarm Action	R/W	0 – 7	T43
Jam							
64	40065	64-04-01	3:64	Trip Action	R/W	0 – 7	T42
65		64-04-03		Trip Level	R/W	1 – 10 x FLA	T1 (low)
66							T1 (high)
67		64-04-04		Trip Delay	R/W	1 – 100 s	T1 (low)
68							T1 (high)
69		64-04-05		Alarm Level	R/W	1 – 10 x FLA	T1 (low)
70							T1 (high)
71		64-04-06		Alarm Delay	R/W	1 – 100 s	T1 (low)
72							T1 (high)
73		64-04-02		Alarm Action	R/W	0 – 7	T43
Current Unbalance							
80	40081	64-05-01	3:80	Trip Action	R/W	0 – 7	T42
81		64-05-03		Trip Level (per unit based on I ₂ /I ₁)	R/W	0.05 – 1.0	T1 (low)
82							T1 (high)
83		64-05-04		Trip Delay	R/W	1.0 – 100 s	T1 (low)
84							T1 (high)
85		64-05-05		Alarm Level (per unit based on I ₂ /I ₁)	R/W	0.05 – 1.0	T1 (low)
86							T1 (high)
87		64-05-06		Alarm Delay	R/W	1.0 – 100 s	T1 (low)
88							T1 (high)
89		64-05-02		Alarm Action	R/W	0 – 7	T43

PGR-6200 REGISTER (DECIMAL)	MODBUS REGISTER (DECIMAL)	DEVICENET (Hex) (NOTE 10)	A-B FILE (DECIMAL) (NOTE 4)	DESCRIPTION	ACCESS	RANGE	TYPE (NOTE 2)
Phase Reverse							
93	40094	64-06-02	3:93	Alarm Action	R/W	0 – 7	T43
94		64-06-06		Alarm Delay	R/W	1 – 100 s	T1(low)
95							T1(high)
96		64-06-01		Trip Action	R/W	0 – 7	T42
97		64-06-04		Trip Delay	R/W	1 – 100 s	T1(low)
98							T1(high)
Phase Loss							
99	40100	64-07-01	3:99	Trip Action	R/W	0 – 7	T42
100		64-07-04		Trip Delay	R/W	1 – 100 s	T1(low)
101							T1(high)
102		64-07-02		Alarm Action	R/W	0 - 7	T43
103		64-07-06		Alarm Delay	R/W	1 – 100 s	T1(low)
104							T1(high)
Undercurrent							
128	40129	64-08-01	3:128	Trip Action	R/W	0 – 7	T42
129		64-08-03		Trip Level	R/W	0.1 – 1.0 x FLA	T1(low)
130							T1(high)
131		64-08-04		Trip Delay	R/W	1 – 100 s	T1(low)
132							T1(high)
133		64-08-05		Alarm Level	R/W	0.1 – 1.0 x FLA	T1(low)
134							T1(high)
135		64-08-06		Alarm Delay	R/W	1 – 100 s	T1(low)
136							T1(high)
137		64-08-02		Alarm Action	R/W	0 – 7	T43
Remote Network Control							
140				Remote Net Trip Action	R/W	0 – 7	T42
141				Remote Net Alarm Action	R/W	0 – 7	T43
PTC Temperature							
143		29-01-7F		Sensor Select	R/W	0 – 2	T68
144		64-09-01		Trip Action	R/W	0 – 7	T42
145		64-09-02		Alarm Action	R/W	0 – 7	T43
RTD Temperature (Local)							
146	146	146	146	146	146	146	146
147	147	147	147	147	147	147	147
148	148	148	148	148	148	148	148
149	149	149	149	149	149	149	149
150	150	150	150	150	150	150	150
151	151	151	151	151	151	151	151
Differential Module							
160	160	160	160	160	160	160	160
161	161	161	161	161	161	161	161
162	162	162	162	162	162	162	162

PGR-6200 REGISTER (DECIMAL)	MODBUS REGISTER (DECIMAL)	DEVICENET (Hex) (NOTE 10)	A-B FILE (DECIMAL) (NOTE 4)	DESCRIPTION	ACCESS	RANGE	TYPE (NOTE 2)
Differential Protection							
170	40171	65-0C-01	3:170	Trip Action	R/W	0 – 7	T42
171		65-0C-03		Trip Level	R/W	0.1-15 x I _d	T1(low)
172							T1(high)
173		65-0C-04		Trip Delay	R/W	0 – 10 s	T1(low)
174							T1(high)
175		65-0C-05		Alarm Level	R/W	0.1-15 x I _d	T1(low)
176							T1(high)
177		65-0C-06		Alarm Delay	R/W	0 – 10 s	T1(low)
178							T1(high)
179		65-0C-02		Alarm Action	R/W	0 – 7	T43
System Ratings							
208	40209	2C-01-71	3:208	Earth-Fault-CT Source	R/W	0 – 1	T60
210		2C-01-72		CT Primary	R/W	1 – 5,000 A	T1(low)
211							T1(high)
212		2C-01-73		EF-CT Primary	R/W	1 – 5,000 A	T1(low)
213							T1(high)
216	40217	2C-01-74	3:216	Run-Mode Delay	R/W	5 – 60 s	T1(low)
217							T1(high)
218		2C-01-77		Differential CT Primary Rating	R/W	1 – 5,000 A	T1(low)
219							T1(high)
224	40225	2C-01-75	3:224	Frequency	R/W	0 – 2	T70
225		2C-01-76		Full-Load Rating	R/W	1 – 5,000 A	T1(low)
226							T1(high)
233		2C-01-78		Service Factor	R/W	1 – 1.25	T1(low)
234							T1(high)
OPI							
237	40238	29-01-7D	3:237	Display-Loss Trip Action	R/W	0 – 7	T42
239		01-01-67		Password Timeout	R/W	1 – 60 m	T1 (low)
240							T1 (high)
241		29-01-84		UPI LED	R/W	0 – 18	T71
Digital Input							
264	264	264	264	264	264	264	264
265	265	265	265	265	265	265	265
266	266	266	266	266	266	266	266
267	267	267	267	267	267	267	267
268	268	268	268	268	268	268	268
269	269	269	269	269	269	269	269

PGR-6200 REGISTER (DECIMAL)	MODBUS REGISTER (DECIMAL)	DEVICENET (Hex) (NOTE 10)	A-B FILE (DECIMAL) (NOTE 4)	DESCRIPTION	ACCESS	RANGE	TYPE (NOTE 2)	
Relay Output Function								
334	40335	29-01-6F	3:334	Relay 1 Output Function	R/W	0 – 13	T62	
335		29-01-70		Relay 1 Mode	R/W	0 – 1	T14	
336		29-01-71		Relay 2 Output Function	R/W	0 – 13	T62	
337		29-01-72		Relay 2 Mode	R/W	0 – 1	T14	
338		29-01-73		Relay 3 Output Function	R/W	0 – 13	T62	
339		29-01-74		Relay 3 Mode	R/W	0 – 1	T14	
344		29-01-75		RY Pulse Time	R/W	0.05 – 10 s	T1(low)	
345							T1(high)	
Analog Output								
373	40374	29-01-7B	3:373	Output Parameter	R/W	0 – 12	T63	
				(See Registers 856-859 for Analog Output Calibration)				
Network and TIA-232 Communications								
374	40375	05-00-65	3:374	DeviceNet Producing Instance	R/W	0 - 5	T84	
375		05-00-64		DeviceNet Consuming Instance	R/W	0 - 2	T85	
376	40377		3:376	Network Type	R/W	0 – 6	T65	
377				Network Baud Rate	R/W	0 – 5	T69	
378				Network Error Check	R/W	0 – 2	T18	
379				Network ID	R/W	0 – 255	T1(low)	
380							T1(high)	
381				Network Trip Action	R/W	0 – 7	T42	
382				Network Alarm Action	R/W	0 – 7	T43	
383				TIA-232 Baud Rate	R/W	0 – 2	T66	
384				TIA-232 ID	R/W	0 – 255	T1(low)	
385							T1(high)	
RTD Module (PGA-0120)								
386	40387	65-00-68	3:385	RTD-Module-Error Alarm Action	R/W	0 – 7	T43	
387		65-00-67		RTD-Module-Error Trip Action	R/W	0 – 7	T42	
388		65-00-65		RTD-Sensor-Error Trip Action ⁽⁹⁾	R/W	0 – 7	T42	
389		65-00-66		RTD-Sensor-Error Alarm Action ⁽⁹⁾	R/W	0 – 7	T43	
390	40391	65-00-64	4:0	Number of RTD Modules	R/W	0 – 3	T19	
RTD Type								
391	40392	65-01-01	4:1	Module 1 #1 Type	R/W	0 – 4	T20	
392		65-01-02		Module 1 #2 Type	R/W	0 – 4	T20	
393		65-01-03		Module 1 #3 Type	R/W	0 – 4	T20	
394		65-01-04		Module 1 #4 Type	R/W	0 – 4	T20	
395		65-01-05		Module 1 #5 Type	R/W	0 – 4	T20	
396		65-01-06		Module 1 #6 Type	R/W	0 – 4	T20	
397		65-01-07		Module 1 #7 Type	R/W	0 – 4	T20	
398		65-01-08		Module 1 #8 Type	R/W	0 – 4	T20	
399		65-02-01		Module 2 #1 Type	R/W	0 – 4	T20	
400		65-02-02		Module 2 #2 Type	R/W	0 – 4	T20	
401		65-02-03		Module 2 #3 Type	R/W	0 – 4	T20	
402		65-02-04		Module 2 #4 Type	R/W	0 – 4	T20	
403		65-02-05		Module 2 #5 Type	R/W	0 – 4	T20	

PGR-6200 REGISTER (DECIMAL)	MODBUS REGISTER (DECIMAL)	DEVICENET (Hex) (NOTE 10)	A-B FILE (DECIMAL) (NOTE 4)	DESCRIPTION	ACCESS	RANGE	TYPE (NOTE 2)
404		65-02-06		Module 2 #6 Type	R/W	0 – 4	T20
405		65-02-07		Module 2 #7 Type	R/W	0 – 4	T20
406		65-02-08		Module 2 #8 Type	R/W	0 – 4	T20
407		65-03-01		Module 3 #1 Type	R/W	0 – 4	T20
408		65-03-02		Module 3 #2 Type	R/W	0 – 4	T20
409		65-03-03		Module 3 #3 Type	R/W	0 – 4	T20
410		65-03-04		Module 3 #4 Type	R/W	0 – 4	T20
411		65-03-05		Module 3 #5 Type	R/W	0 – 4	T20
412		65-03-06		Module 3 #6 Type	R/W	0 – 4	T20
413		65-03-07		Module 3 #7 Type	R/W	0 – 4	T20
414		65-03-08		Module 3 #8 Type	R/W	0 – 4	T20
RTD Function							
415	40416	65-01-09	4:25	Module 1 #1 Function	R/W	0 – 3	T21
416		65-01-0A		Module 1 #2 Function	R/W	0 – 3	T21
417		65-01-0B		Module 1 #3 Function	R/W	0 – 3	T21
418		65-01-0C		Module 1 #4 Function	R/W	0 – 3	T21
419		65-01-0D		Module 1 #5 Function	R/W	0 – 3	T21
420		65-01-0E		Module 1 #6 Function	R/W	0 – 3	T21
421		65-01-0F		Module 1 #7 Function	R/W	0 – 3	T21
422		65-01-10		Module 1 #8 Function	R/W	0 – 3	T21
423		65-02-09		Module 2 #1 Function	R/W	0 – 3	T21
424		65-02-0A		Module 2 #2 Function	R/W	0 – 3	T21
425		65-02-0B		Module 2 #3 Function	R/W	0 – 3	T21
426		65-02-0C		Module 2 #4 Function	R/W	0 – 3	T21
427		65-02-0D		Module 2 #5 Function	R/W	0 – 3	T21
428		65-02-0E		Module 2 #6 Function	R/W	0 – 3	T21
429		65-02-0F		Module 2 #7 Function	R/W	0 – 3	T21
430		65-02-10		Module 2 #8 Function	R/W	0 – 3	T21
431		65-03-09		Module 3 #1 Function	R/W	0 – 3	T21
432		65-03-0A		Module 3 #2 Function	R/W	0 – 3	T21
433		65-03-0B		Module 3 #3 Function	R/W	0 – 3	T21
434		65-03-0C		Module 3 #4 Function	R/W	0 – 3	T21
435		65-03-0D		Module 3 #5 Function	R/W	0 – 3	T21
436		65-03-0E		Module 3 #6 Function	R/W	0 – 3	T21
437		65-03-0F		Module 3 #7 Function	R/W	0 – 3	T21
438		65-03-10		Module 3 #8 Function	R/W	0 – 3	T21

PGR-6200 REGISTER (DECIMAL)	MODBUS REGISTER (DECIMAL)	DEVICENET (Hex) (NOTE 10)	A-B FILE (DECIMAL) (NOTE 4)	DESCRIPTION	ACCESS	RANGE	TYPE (NOTE 2)
RTD Trip1/Alarm1 Setpoints							
446	40447	65-01-11	4:56	Module 1 #1 Trip Level	R/W	40 – 200°C	T1(low)
447							T1(high)
448		65-01-12		Module 1 #1 Alarm Level	R/W	40 – 200°C	T1(low)
449							T1(high)
450		65-01-13		Module 1 #2 Trip Level	R/W	40 – 200°C	T1(low)
451							T1(high)
452		65-01-14		Module 1 #2 Alarm Level	R/W	40 – 200°C	T1(low)
453							T1(high)
454		65-01-15		Module 1 #3 Trip Level	R/W	40 – 200°C	T1(low)
455							T1(high)
456		65-01-16		Module 1 #3 Alarm Level	R/W	40 – 200°C	T1(low)
457							T1(high)
458		65-01-17		Module 1 #4 Trip Level	R/W	40 – 200°C	T1(low)
459							T1(high)
460		65-01-18		Module 1 #4 Alarm Level	R/W	40 – 200°C	T1(low)
461							T1(high)
462		65-01-19		Module 1 #5 Trip Level	R/W	40 – 200°C	T1(low)
463							T1(high)
464		65-01-1A		Module 1 #5 Alarm Level	R/W	40 – 200°C	T1(low)
465							T1(high)
466		65-01-1B		Module 1 #6 Trip Level	R/W	40 – 200°C	T1(low)
467							T1(high)
468		65-01-1C		Module 1 #6 Alarm Level	R/W	40 – 200°C	T1(low)
469							T1(high)
470		65-01-1D		Module 1 #7 Trip Level	R/W	40 – 200°C	T1(low)
471							T1(high)
472		65-01-1E		Module 1 #7 Alarm Level	R/W	40 – 200°C	T1(low)
473							T1(high)
474		65-01-1F		Module 1 #8 Trip Level	R/W	40 – 200°C	T1(low)
475							T1(high)
476		65-01-20		Module 1 #8 Alarm Level	R/W	40 – 200°C	T1(low)
477							T1(high)
478		65-02-11		Module 2 #1 Trip Level	R/W	40 – 200°C	T1(low)
479							T1(high)
480		65-02-12		Module 2 #1 Alarm Level	R/W	40 – 200°C	T1(low)
481							T1(high)
482		65-02-13		Module 2 #2 Trip Level	R/W	40 – 200°C	T1(low)
483							T1(high)
484		65-02-14		Module 2 #2 Alarm Level	R/W	40 – 200°C	T1(low)
485							T1(high)
486		65-02-15		Module 2 #3 Trip Level	R/W	40 – 200°C	T1(low)
487							T1(high)
488		65-02-16		Module 2 #3 Alarm Level	R/W	40 – 200°C	T1(low)
489							T1(high)

PGR-6200 REGISTER (DECIMAL)	MODBUS REGISTER (DECIMAL)	DEVICENET (Hex) (NOTE 10)	A-B FILE (DECIMAL) (NOTE 4)	DESCRIPTION	ACCESS	RANGE	TYPE (NOTE 2)
490		65-02-17		Module 2 #4 Trip Level	R/W	40 – 200°C	T1(low)
491							T1(high)
492		65-02-18		Module 2 #4 Alarm Level	R/W	40 – 200°C	T1(low)
493							T1(high)
494		65-02-19		Module 2 #5 Trip Level	R/W	40 – 200°C	T1(low)
495							T1(high)
496		65-02-1A		Module 2 #5 Alarm Level	R/W	40 – 200°C	T1(low)
497							T1(high)
498		65-02-1B		Module 2 #6 Trip Level	R/W	40 – 200°C	T1(low)
499							T1(high)
500		65-02-1C		Module 2 #6 Alarm Level	R/W	40 – 200°C	T1(low)
501							T1(high)
502		65-02-1D		Module 2 #7 Trip Level	R/W	40 – 200°C	T1(low)
503							T1(high)
504		65-02-1E		Module 2 #7 Alarm Level	R/W	40 – 200°C	T1(low)
505							T1(high)
506		65-02-1F		Module 2 #8 Trip Level	R/W	40 – 200°C	T1(low)
507							T1(high)
508		65-02-20		Module 2 #8 Alarm Level	R/W	40 – 200°C	T1(low)
509							T1(high)
510		65-03-11		Module 3 #1 Trip Level	R/W	40 – 200°C	T1(low)
511							T1(high)
512		65-03-12		Module 3 #1 Alarm Level	R/W	40 – 200°C	T1(low)
513							T1(high)
514		65-03-13		Module 3 #2 Trip Level	R/W	40 – 200°C	T1(low)
515							T1(high)
516		65-03-14		Module 3 #2 Alarm Level	R/W	40 – 200°C	T1(low)
517							T1(high)
518		65-03-15		Module 3 #3 Trip Level	R/W	40 – 200°C	T1(low)
519							T1(high)
520		65-03-16		Module 3 #3 Alarm Level	R/W	40 – 200°C	T1(low)
521							T1(high)
522		65-03-17		Module 3 #4 Trip Level	R/W	40 – 200°C	T1(low)
523							T1(high)
524		65-03-18		Module 3 #4 Alarm Level	R/W	40 – 200°C	T1(low)
525							T1(high)
526		65-03-19		Module 3 #5 Trip Level	R/W	40 – 200°C	T1(low)
527							T1(high)
528		65-03-1A		Module 3 #5 Alarm Level	R/W	40 – 200°C	T1(low)
529							T1(high)
530		65-03-1B		Module 3 #6 Trip Level	R/W	40 – 200°C	T1(low)
531							T1(high)
532		65-03-1C		Module 3 #6 Alarm Level	R/W	40 – 200°C	T1(low)
533							T1(high)
534		65-03-1D		Module 3 #7 Trip Level	R/W	40 – 200°C	T1(low)

PGR-6200 REGISTER (DECIMAL)	MODBUS REGISTER (DECIMAL)	DEVICENET (Hex) (NOTE 10)	A-B FILE (DECIMAL) (NOTE 4)	DESCRIPTION	ACCESS	RANGE	TYPE (NOTE 2)
535							T1(high)
536		65-03-1E		Module 3 #7 Alarm Level	R/W	40 – 200°C	T1(low)
537							T1(high)
538		65-03-1F		Module 3 #8 Trip Level	R/W	40 – 200°C	T1(low)
539							T1(high)
540		65-03-20		Module 3 #8 Alarm Level	R/W	40 – 200°C	T1(low)
541							T1(high)
Hot Motor Compensation							
550	40551	65-00-6D	4:160	HMC Enable	R/W	0 – 1	T6
551		65-00-6E		HMC High	R/W	40 – 200°C	T1(low)
552							T1(high)
553		65-00-6F		HMC Low	R/W	40 – 200°C	T1(low)
554							T1(high)
Clock Reading							
574	40575	66-01-01	5:0	RTC Date	Read Only		T23(low)
575							T23(high)
576		66-01-02		RTC Time	Read Only		T24(low)
577							T24(high)
Strings							
580	40581	66-01-03	5:6	Clock String (setting only)	R/W		T31
590		01-01-66		Password (first four characters)	R/W		T22
600		01-01-65		System Name	R/W		T22
610		65-01-21		RTD Module 1 #1 Name	R/W		T22
620		65-01-22		RTD Module 1 #2 Name	R/W		T22
630		65-01-23		RTD Module 1 #3 Name	R/W		T22
640		65-01-24		RTD Module 1 #4 Name	R/W		T22
650		65-01-25		RTD Module 1 #5 Name	R/W		T22
660		65-01-26		RTD Module 1 #6 Name	R/W		T22
670		65-01-27		RTD Module 1 #7 Name	R/W		T22
680		65-01-28		RTD Module 1 #8 Name	R/W		T22
690		65-02-21		RTD Module 2 #1 Name	R/W		T22
700		65-02-22		RTD Module 2 #2 Name	R/W		T22
710		65-02-23		RTD Module 2 #3 Name	R/W		T22
720		65-02-24		RTD Module 2 #4 Name	R/W		T22
730		65-02-25		RTD Module 2 #5 Name	R/W		T22
740		65-02-26		RTD Module 2 #6 Name	R/W		T22
750		65-02-27		RTD Module 2 #7 Name	R/W		T22
760		65-02-28		RTD Module 2 #8 Name	R/W		T22
770		65-03-21		RTD Module 3 #1 Name	R/W		T22
780		65-03-22		RTD Module 3 #2 Name	R/W		T22
790		65-03-23		RTD Module 3 #3 Name	R/W		T22
800		65-03-24		RTD Module 3 #4 Name	R/W		T22
810		65-03-25		RTD Module 3 #5 Name	R/W		T22
820		65-03-26		RTD Module 3 #6 Name	R/W		T22
830		65-03-27		RTD Module 3 #7 Name	R/W		T22
840		65-03-28		RTD Module 3 #8 Name	R/W		T22

PGR-6200 REGISTER (DECIMAL)	MODBUS REGISTER (DECIMAL)	DEVICENET (Hex) (NOTE 10)	A-B FILE (DECIMAL) (NOTE 4)	DESCRIPTION	ACCESS	RANGE	TYPE (NOTE 2)
Analog Output Calibration							
856	40857		5:282	Analog-Output Calibration (zero)	R/W	0 – 1000	T1(low)
857							T1(high)
858				Analog-Output Calibration (FS)	R/W	0 – 1000	T1(low)
859							T1(high)
Meter Values							
860	40861	2C-01-90	6:0	I_a (A)	Read Only		T1(low)
861							T1(high)
862		2C-01-91		I_b (A)	Read Only		T1(low)
863							T1(high)
864		2C-01-92		I_c (A)	Read Only		T1(low)
865							T1(high)
866		2C-01-93		I_{ct} (A) Earth Fault Measured	Read Only		T1(low)
867							T1(high)
868		2C-01-94		$3I_o$ (A) Earth Fault Calculated	Read Only		T1(low)
869							T1(high)
870		2C-01-95		Positive-Sequence Current (pu)	Read Only		T1(low)
871							T1(high)
872		2C-01-96		Negative-Sequence Current (pu)	Read Only		T1(low)
873							T1(high)
874		2C-01-97		Unbalance in pu	Read Only		T1(low)
875							T1(high)
876		2C-01-98		Used I^2t (pu)	Read Only		T1(low)
877							T1(high)
878		2C-01-99		Trend I^2t (pu)	Read Only		T1(low)
879							T1(high)
880		2C-01-9A		Frequency	Read Only		T1 (low)
881							T1 (high)
882		2C-01-9E		I^2t Reset/Trip Time/Inhibit Time (min)	Read Only		T1 (low)
883							T1 (high)
884	40885	C2-01-9F		Differential Current Phase A (A)	Read Only		T1 (low)
885							T1 (high)
886		C2-01-A0		Differential Current Phase B (A)	Read Only		T1 (low)
887							T1 (high)
888		C2-01-A1		Differential Current Phase C (A)	Read Only		T1 (low)
889							T1 (high)
900		2C-01-9B		Local RTD Reading	Read Only		T1(low)
901							T1(high)
902		65-01-29		Module 1 #1 Temperature °C	Read Only		T1(low)
903							T1(high)
904		65-01-2A		Module 1 #2 Temperature °C	Read Only		T1(low)
905							T1(high)
906		65-01-2B		Module 1 #3 Temperature °C	Read Only		T1(low)
907							T1(high)

PGR-6200 REGISTER (DECIMAL)	MODBUS REGISTER (DECIMAL)	DEVICENET (Hex) (NOTE 10)	A-B FILE (DECIMAL) (NOTE 4)	DESCRIPTION	ACCESS	RANGE	TYPE (NOTE 2)
908		65-01-2C		Module 1 #4 Temperature °C	Read Only		T1(low)
909							T1(high)
910		65-01-2D		Module 1 #5 Temperature °C	Read Only		T1(low)
911							T1(high)
912		65-01-2E		Module 1 #6 Temperature °C	Read Only		T1(low)
913							T1(high)
914		65-01-2F		Module 1 #7 Temperature °C	Read Only		T1(low)
915							T1(high)
916		65-01-30		Module 1 #8 Temperature °C	Read Only		T1(low)
917							T1(high)
918		65-02-29		Module 2 #1 Temperature °C	Read Only		T1(low)
919							T1(high)
920		65-02-2A		Module 2 #2 Temperature °C	Read Only		T1(low)
921							T1(high)
922		65-02-2B		Module 2 #3 Temperature °C	Read Only		T1(low)
923							T1(high)
924		65-02-2C		Module 2 #4 Temperature °C	Read Only		T1(low)
925							T1(high)
926		65-02-2D		Module 2 #5 Temperature °C	Read Only		T1(low)
927							T1(high)
928		65-02-2E		Module 2 #6 Temperature °C	Read Only		T1(low)
929							T1(high)
930		65-02-2F		Module 2 #7 Temperature °C	Read Only		T1(low)
931							T1(high)
932		65-02-30		Module 2 #8 Temperature °C	Read Only		T1(low)
933							T1(high)
934		65-03-29		Module 3 #1 Temperature °C	Read Only		T1(low)
935							T1(high)
936		65-03-2A		Module 3 #2 Temperature °C	Read Only		T1(low)
937							T1(high)
938		65-03-2B		Module 3 #3 Temperature °C	Read Only		T1(low)
939							T1(high)
940		65-03-2C		Module 3 #4 Temperature °C	Read Only		T1(low)
941							T1(high)
942		65-03-2D		Module 3 #5 Temperature °C	Read Only		T1(low)
943							T1(high)
944		65-03-2E		Module 3 #6 Temperature °C	Read Only		T1(low)
945							T1(high)
946		65-03-2F		Module 3 #7 Temperature °C	Read Only		T1(low)
947							T1(high)
948		65-03-30		Module 3 #8 Temperature °C	Read Only		T1(low)
949							T1(high)
950		65-00-70		Max Stator Temperature °C ⁽⁶⁾	Read Only		T1(low)
951							T1(high)

PGR-6200 REGISTER (DECIMAL)	MODBUS REGISTER (DECIMAL)	DEVICENET (Hex) (NOTE 10)	A-B FILE (DECIMAL) (NOTE 4)	DESCRIPTION	ACCESS	RANGE	TYPE (NOTE 2)
952		65-00-71		Max Bearing Temperature °C ⁽⁶⁾	Read Only		T1(low)
953							T1(high)
954		65-00-72		Max Load Temperature °C ⁽⁶⁾	Read Only		T1(low)
955							T1(high)
956		65-00-73		Max Ambient Temperature °C ⁽⁶⁾	Read Only		T1(low)
957							T1(high)
958		65-00-74		Min Stator Temperature °C ⁽⁷⁾	Read Only		T1(low)
959							T1(high)
960		65-00-75		Min Bearing Temperature °C ⁽⁷⁾	Read Only		T1(low)
961							T1(high)
962		65-00-76		Min Load Temperature °C ⁽⁷⁾	Read Only		T1(low)
963							T1(high)
964		65-00-77		Min Ambient Temperature °C ⁽⁷⁾	Read Only		T1(low)
965							T1(high)
Event Records							
973	40974	68-01-01	7:0	Number of Records	Read Only	0 – 65535	T3
974		68-01-02		Record Head (Next Record)	Read Only	0 – 99	T3
975		68-01-03		Record Selector	R/W	0 – 99	T3
976		68-01-04		Record Date	Read Only		T23(low)
977							T23(high)
978		68-01-05		Record Time	Read Only		T24(low)
979							T24(high)
980		68-01-06		Record Type	Read Only		T26
981		68-01-07		Message Code	Read Only		T27
982		68-01-08		I _a ⁽¹⁾	Read Only		T1(low)
983							T1(high)
984		68-01-09		I _b ⁽¹⁾	Read Only		T1(low)
985							T1(high)
986		68-01-0A		I _c ⁽¹⁾	Read Only		T1(low)
987							T1(high)
988		68-01-0B		I _g ^(1, 11)	Read Only		T1(low)
989							T1(high)
990		68-01-0C		Differential Current Phase A (A)	Read Only		T1(low)
991							T1(high)
992		68-01-0D		Differential Current Phase B (A)	Read Only		T1(low)
993							T1(high)
994		68-01-0E		Differential Current Phase C (A)	Read Only		T1(low)
995							T1(high)
996		68-01-0F		Reserved	Read Only		T1(low)
997							T1(high)
998		68-01-10		Current Unbalance ⁽¹⁾	Read Only		T1(low)
999							T1(high)
1000		68-01-11		Local RTD Reading	Read Only		T1(low)
1001							T1(high)
1002		68-01-12		Start Time	Read Only		T3

PGR-6200 REGISTER (DECIMAL)	MODBUS REGISTER (DECIMAL)	DEVICENET (Hex) (NOTE 10)	A-B FILE (DECIMAL) (NOTE 4)	DESCRIPTION	ACCESS	RANGE	TYPE (NOTE 2)
1003		68-01-13		Used I^2t ⁽³⁾	Read Only		T1(low)
1004							T1(high)
1005		68-01-14		Module 1 #1 Temperature	Read Only		T1(low)
1006							T1(high)
1007		68-01-15		Module 1 #2 Temperature	Read Only		T1(low)
1008							T1(high)
1009		68-01-16		Module 1 #3 Temperature	Read Only		T1(low)
1010							T1(high)
1011		68-01-17		Module 1 #4 Temperature	Read Only		T1(low)
1012							T1(high)
1013		68-01-18		Module 1 #5 Temperature	Read Only		T1(low)
1014							T1(high)
1015		68-01-19		Module 1 #6 Temperature	Read Only		T1(low)
1016							T1(high)
1017		68-01-1A		Module 1 #7 Temperature	Read Only		T1(low)
1018							T1(high)
1019		68-01-1B		Module 1 #8 Temperature	Read Only		T1(low)
1020							T1(high)
1021		68-01-1C		Module 2 #1 Temperature	Read Only		T1(low)
1022							T1(high)
1023		68-01-1D		Module 2 #2 Temperature	Read Only		T1(low)
1024							T1(high)
1025		68-01-1E		Module 2 #3 Temperature	Read Only		T1(low)
1026							T1(high)
1027		68-01-1F		Module 2 #4 Temperature	Read Only		T1(low)
1028							T1(high)
1029		68-01-20		Module 2 #5 Temperature	Read Only		T1(low)
1030							T1(high)
1031		68-01-21		Module 2 #6 Temperature	Read Only		T1(low)
1032							T1(high)
1033		68-01-22		Module 2 #7 Temperature	Read Only		T1(low)
1034							T1(high)
1035		68-01-23		Module 2 #8 Temperature	Read Only		T1(low)
1036							T1(high)
1037		68-01-24		Module 3 #1 Temperature	Read Only		T1(low)
1038							T1(high)
1039		68-01-25		Module 3 #2 Temperature	Read Only		T1(low)
1040							T1(high)
1041		68-01-26		Module 3 #3 Temperature	Read Only		T1(low)
1042							T1(high)
1043		68-01-27		Module 3 #4 Temperature	Read Only		T1(low)
1044							T1(high)
1045		68-01-28		Module 3 #5 Temperature	Read Only		T1(low)
1046							T1(high)

PGR-6200 REGISTER (DECIMAL)	MODBUS REGISTER (DECIMAL)	DEVICENET (Hex) (NOTE 10)	A-B FILE (DECIMAL) (NOTE 4)	DESCRIPTION	ACCESS	RANGE	TYPE (NOTE 2)
1047		68-01-29		Module 3 #6 Temperature	Read Only		T1(low)
1048							T1(high)
1049		68-01-2A		Module 3 #7 Temperature	Read Only		T1(low)
1050							T1(high)
1051		68-01-2B		Module 3 #8 Temperature	Read Only		T1(low)
1052							T1(high)
1053				Reserved	Read Only	0	T1(low)
1054							T1(high)
1055				Reserved	Read Only	0	T1(low)
1056							T1(high)
1057				Reserved	Read Only	0	T1(low)
1058							T1(high)
1059				Reserved	Read Only	0	T1(low)
1060							T1(high)
1061				Reserved	Read Only	0	T1(low)
1062							T1(high)
Status							
1096	41097	29-01-65	8:0	Trip and Alarm Summary	Read Only		T67
1097		29-01-66		PGR-6200 Status	Read Only		T44
Message Stack							
1104	41105	29-01-67	8:8	Group0 Code Bits ⁽⁸⁾ 15.. 0	Read Only		T45
1105		29-01-68		Group1 Code Bits ⁽⁸⁾ 31 .. 16	Read Only		T46
1106		29-01-69		Group2 Code Bits ⁽⁸⁾ 47 .. 32	Read Only		T47
1107		29-01-6A		Group3 Code Bits ⁽⁸⁾ 63 .. 48	Read Only		T48
1108		29-01-6B		Group4 Code Bits ⁽⁸⁾ 79 .. 64	Read Only		T49
1109		29-01-6C		Group5 Code Bits ⁽⁸⁾ 95 .. 80	Read Only		T50
1110		29-01-6D		Group6 Code Bits ⁽⁸⁾ 111 .. 96	Read Only		T51
1111		29-01-6E		Group7 Code Bits ⁽⁸⁾ 127 .. 112	Read Only		T52
1112		29-01-88		Group8 Code Bits ⁽⁸⁾ 143 .. 128	Read Only		T53
Trip Counters							
1130	41131	64-01-07	8:34	Overcurrent	Read Only		T3
1131		64-02-07		AUX Overcurrent	Read Only		T3
1132		2C-01-79		Overload	Read Only		T3
1133		64-03-07		Earth Fault	Read Only		T3
1134		64-05-07		Current Unbalance	Read Only		T3
1136		64-04-07		Jam	Read Only		T3
1137		64-08-07		Undercurrent	Read Only		T3
1138		29-01-87		Differential Module Trip	Read Only		T3
1139		65-0C-07		Differential Current Trip	Read Only		T3
1140		65-0B-07		Reduced Overcurrent Trip	Read Only		T3
1142		64-09-07		PTC	Read Only		T3
1143		64-07-07		Phase-Loss	Read Only		T3
1144		64-06-07		Phase-Reverse	Read Only		T3
1149		29-01-7A		Digital Trip	Read Only		T3
1156		65-01-31		RTD Module 1 #1	Read Only		T3

PGR-6200 REGISTER (DECIMAL)	MODBUS REGISTER (DECIMAL)	DEVICENET (Hex) (NOTE 10)	A-B FILE (DECIMAL) (NOTE 4)	DESCRIPTION	ACCESS	RANGE	TYPE (NOTE 2)
1157		65-01-32		RTD Module 1 #2	Read Only		T3
1158		65-01-33		RTD Module 1 #3	Read Only		T3
1159		65-01-34		RTD Module 1 #4	Read Only		T3
1160		65-01-35		RTD Module 1 #5	Read Only		T3
1161		65-01-36		RTD Module 1 #6	Read Only		T3
1162		65-01-37		RTD Module 1 #7	Read Only		T3
1163		65-01-38		RTD Module 1 #8	Read Only		T3
1164		65-02-31		RTD Module 2 #1	Read Only		T3
1165		65-02-32		RTD Module 2 #2	Read Only		T3
1166		65-02-33		RTD Module 2 #3	Read Only		T3
1167		65-02-34		RTD Module 2 #4	Read Only		T3
1168		65-02-35		RTD Module 2 #5	Read Only		T3
1169		65-02-36		RTD Module 2 #6	Read Only		T3
1170		65-02-37		RTD Module 2 #7	Read Only		T3
1171		65-02-38		RTD Module 2 #8	Read Only		T3
1172		65-03-31		RTD Module 3 #1	Read Only		T3
1173		65-03-32		RTD Module 3 #2	Read Only		T3
1174		65-03-33		RTD Module 3 #3	Read Only		T3
1175		65-03-34		RTD Module 3 #4	Read Only		T3
1176		65-03-35		RTD Module 3 #5	Read Only		T3
1177		65-03-36		RTD Module 3 #6	Read Only		T3
1178		65-03-37		RTD Module 3 #7	Read Only		T3
1179		65-03-38		RTD Module 3 #8	Read Only		T3
1180		65-00-69		RTD Module 1 Comm	Read Only		T3
1181		65-00-6A		RTD Module 2 Comm	Read Only		T3
1182		65-00-6B		RTD Module 3 Comm	Read Only		T3
1183		65-00-6C		RTD Module Sensor	Read Only		T3
1185		29-01-7E		Display Comm	Read Only		T3
1190				A/D	Read Only		T3
1191		03-01-66		Network	Read Only		T3
1193		2C-01-7E		Starts per Hour	Read Only		T3
1194		64-0A-07		RTD Temperature (Local)	Read Only		T3
1195		29-01-80		RTD Sensor (Local)	Read Only		T3
1196		2C-01-70		I ² t Inhibit	Read Only		T3
1197		29-01-82		Remote/Network	Read Only		T3
Running Time							
1210	41211	2C-01-9C	9:0	Running Seconds	Read Only		T2(low)
1211							T2(high)
Starts per Hour							
1270	41271	2C-01-7A	9:60	Trip Action	R/W	0 – 7	T42
1271		2C-01-7B		Alarm Action	R/W	0 – 7	T43
1272		2C-01-7C		Starts per Hour Setting	R/W	0 – 9	T25
1273		2C-01-7D		Time Between Starts	R/W	0 – 500m	T1(low)
1274							T1(high)

PGR-6200 REGISTER (DECIMAL)	MODBUS REGISTER (DECIMAL)	DEVICENET (Hex) (NOTE 10)	A-B FILE (DECIMAL) (NOTE 4)	DESCRIPTION	ACCESS	RANGE	TYPE (NOTE 2)
Ethernet							
1280	41281		9:70	IP Address	R/W		T22
1290				Address Mask	R/W		T22
1300				Gateway Address	R/W		T22
1310				MAC Address	Read Only		T22
User Defined Registers							
1400	41401	67-01-01	9:190	User Register 0	R/W	0 - 1399	T3
1401		67-01-02		User Register 1	R/W	0 - 1399	T3
1402		67-01-03		User Register 2	R/W	0 - 1399	T3
1403		67-01-04		User Register 3	R/W	0 - 1399	T3
1404		67-01-05		User Register 4	R/W	0 - 1399	T3
1405		67-01-06		User Register 5	R/W	0 - 1399	T3
1406		67-01-07		User Register 6	R/W	0 - 1399	T3
1407		67-01-08		User Register 7	R/W	0 - 1399	T3
1408		67-01-09		User Register 8	R/W	0 - 1399	T3
1409		67-01-0A		User Register 9	R/W	0 - 1399	T3
1410		67-01-0B		User Register 10	R/W	0 - 1399	T3
1411		67-01-0C		User Register 11	R/W	0 - 1399	T3
1412		67-01-0D		User Register 12	R/W	0 - 1399	T3
1413		67-01-0E		User Register 13	R/W	0 - 1399	T3
1414		67-01-0F		User Register 14	R/W	0 - 1399	T3
1415		67-01-10		User Register 15	R/W	0 - 1399	T3
1416		67-01-11		User Register 16	R/W	0 - 1399	T3
1417		67-01-12		User Register 17	R/W	0 - 1399	T3
1418		67-01-13		User Register 18	R/W	0 - 1399	T3
1419		67-01-14		User Register 19	R/W	0 - 1399	T3
1420		67-01-15		User Register 20	R/W	0 - 1399	T3
1421		67-01-16		User Register 21	R/W	0 - 1399	T3
1422		67-01-17		User Register 22	R/W	0 - 1399	T3
1423		67-01-18		User Register 23	R/W	0 - 1399	T3
1424		67-01-19		User Register 24	R/W	0 - 1399	T3
1425		67-01-1A		User Register 25	R/W	0 - 1399	T3
1426		67-01-1B		User Register 26	R/W	0 - 1399	T3
1427		67-01-1C		User Register 27	R/W	0 - 1399	T3
1428		67-01-1D		User Register 28	R/W	0 - 1399	T3
1429		67-01-1E		User Register 29	R/W	0 - 1399	T3
1430		67-01-20		User Register 30	R/W	0 - 1399	T3
1431		67-01-21		User Register 31	R/W	0 - 1399	T3
User Data							
1432	41433		9:222	User Register 0 Data	Read Only	<i>Range and Type defined by user register value.</i>	
1433				User Register 1 Data	Read Only		
1434				User Register 2 Data	Read Only		
1435				User Register 3 Data	Read Only		
1436				User Register 4 Data	Read Only		
1437				User Register 5 Data	Read Only		

PGR-6200 REGISTER (DECIMAL)	MODBUS REGISTER (DECIMAL)	DEVICENET (Hex) (NOTE 10)	A-B FILE (DECIMAL) (NOTE 4)	DESCRIPTION	ACCESS	RANGE	TYPE (NOTE 2)
1438				User Register 6 Data	Read Only		
1439				User Register 7 Data	Read Only		
1440				User Register 8 Data	Read Only		
1441				User Register 9 Data	Read Only		
1442				User Register 10 Data	Read Only		
1443				User Register 11 Data	Read Only		
1444				User Register 12 Data	Read Only		
1445				User Register 13 Data	Read Only		
1446				User Register 14 Data	Read Only		
1447				User Register 15 Data	Read Only		
1448				User Register 16 Data	Read Only		
1449				User Register 17 Data	Read Only		
1450				User Register 18 Data	Read Only		
1451				User Register 19 Data	Read Only		
1452				User Register 20 Data	Read Only		
1453				User Register 21 Data	Read Only		
1454				User Register 22 Data	Read Only		
1455				User Register 23 Data	Read Only		
1456				User Register 24 Data	Read Only		
1457				User Register 25 Data	Read Only		
1458				User Register 26 Data	Read Only		
1459				User Register 27 Data	Read Only		
1460				User Register 28 Data	Read Only		
1461				User Register 29 Data	Read Only		
1462				User Register 30 Data	Read Only		
1463	41464		9:253	User Register 31 Data	Read Only		

Notes:

- (1) If the record type is START, these are the maximum values during the start.
- (2) See Appendix F, Register Formats.
- (3) If the record type is START, this is the I²t used during the start.
- (4) The A-B File is coded as FILE:ELEMENT. To read or write the element as floats, the PLC 5 or SLC 500 address would be <F><FILE>:<ELEMENT> (Example F9:222). To read or write the element as integers using PLC 5 Typed Read and Typed Write commands, add 20 to the file number and precede with N, <N><FILE+20>:<ELEMENT> (Example N29:222). File offset is not required for the SLC 500 Protected Typed Logical Read and Write commands. See PGR-6200 TIA-485 Network Manual.
- (5) Maximum number of registers per read/write is 100 (200 bytes).
- (6) Reading is -40 if there is no maximum value available.
- (7) Reading is 300 if there is no minimum value available.
- (8) The bit number corresponds to the T27 Message Code. The LSB corresponds to the lower message code in the 16-bit number.
- (9) Applies to PGR-6200 or module PGA-0120 sensor.
- (10) Designation is Class – Instance –Attribute.
- (11) Measured value when EF Source is set to Measured (I_{ct}), and calculated value when EF Source is set to calculated (3I₀).

This page intentionally left blank.

**APPENDIX F
REGISTER FORMATS**

TYPE	C TYPE	DESCRIPTION ⁽¹⁾
T1	float	IEEE 32-Bit Floating-Point Number
		Bit 31: Sign
		Bits 30..23: Exponent
		Bits 22..0: Mantissa
		Float (high): Bits 31..16
		Float (low): Bits 15..0
T2	long	32-Bit Integer
T3	short	16-Bit Integer
T4	double	IEEE 64-Bit Floating-Point Number
		Bit 63: Sign
		Bits 62..52: Exponent
		Bits 51..0: Mantissa
		Word 1 (least significant word) ... Word 4 (most significant word)
T6	short	Enable/Disable
		0: Enabled
		1: Disabled
T14	short	Relay Trip/Alarm Mode
		0: Fail Safe
		1: Non Fail Safe
T18	short	Error Checking
		0: Not Selected
		1: CRC Check
		2: BCC Check
T19	short	Number of RTD Modules (PGA-0120)
		0: No RTD Module
		1: 1 RTD Module
		2: 2 RTD Modules
		3: 3 RTD Modules
T20	short	RTD Type
		0: Disable
		1: Platinum 100
		2: Nickel 100
		3: Nickel 120
		4: Copper 10

TYPE	C TYPE	DESCRIPTION ⁽¹⁾
T21	short	RTD Function
		0: Stator
		1: Bearing
		2: Load
		3: Ambient
T22	char	20 ASCII Characters
		Register +0: char[0] and char[1]
		Register +1: char[2] and char[3]
		Register +2: char[4] and char[5]
		Register +3: char[6] and char[7]
		Register +4: char[8] and char[9]
		Register +6: char[10] and char[11]
		Register +7: char[12] and char[13]
		Register +8: char[14] and char[15]
		Register +9: char[16] and char[17]
		Register +10: char[18] and char[19]
		A character value of 0 (Null) will terminate the string and the following characters will be ignored
		Ethernet address strings are of the form: "ddd.ddd.ddd.ddd". The MAC address is a hex string of the form: "hhhhhhhhhhhh"
T23	long	Date
		Bits 31...16: year in binary
		Bits 15..8: 1-12 months in binary
		Bits 7..0: 1-31 days in binary
T24	long	Time
		Bits 31..24: 0-23 hours in binary
		Bits 23..16: 0-60 minutes in binary
		Bits 15..8: 0-60 seconds in binary
		Bits 7..0: 0-99 hundredths of a second in binary
T25	short	Starts-Per-Hour
		0 = 1 Start per Hour
		1 = 2 Starts per Hour
		2 = 3 Starts per Hour
		3 = 4 Starts per Hour
		4 = 5 Starts per Hour
		5 = 6 Starts per Hour
		6 = 7 Starts per Hour
		7 = 8 Starts per Hour
		8 = 9 Starts per Hour
9 = 10 Starts per Hour		



TYPE	C TYPE	DESCRIPTION ⁽¹⁾
T26	short	Record Type
		0: Empty Record
		1: Trip Record
		2: Start Record
		3: ETR Record
T27	short	Message Code
		00: Main Overcurrent Trip
		01: Auxiliary Overcurrent Trip
		02: Overload Trip
		03: Overload Alarm
		04: Earth-Fault Trip
		05: Earth-Fault Alarm
		06: Current-Unbalance Trip
		07: Current-Unbalance Alarm
		08: Reserved
		09: Reserved
		10: Jam Trip
		11: Jam Alarm
		12: Undercurrent Trip
		13: Undercurrent Alarm
		14: Reserved
		15: Reserved
		16: Reserved
		17: Reserved
		18: Reserved
		19: Reserved
		20: Reserved
		21: Reserved
		22: PTC Temperature Trip
		23: PTC Temperature Alarm
		24: Phase-Loss (Current) Trip
		25: Phase-Reverse (Current) Trip
		26: Reserved
		27: Reserved
		28: Reserved
		29: Reserved
		30: Digital 1 Trip
		31: Reserved
		32: Reserved
		33: Reserved
		34: Reserved
		35: Reserved
		36: Reserved
		37: RTD Module 1 INP 1 Trip
38: RTD Module 1 INP 1 Alarm		
39: RTD Module 1 INP 2 Trip		



TYPE	C TYPE	DESCRIPTION ⁽¹⁾
T27		40: RTD Module 1 INP 2 Alarm
		41: RTD Module 1 INP 3 Trip
		42: RTD Module 1 INP 3 Alarm
		43: RTD Module 1 INP 4 Trip
		44: RTD Module 1 INP 4 Alarm
		45: RTD Module 1 INP 5 Trip
		46: RTD Module 1 INP 5 Alarm
		47: RTD Module 1 INP 6 Trip
		48: RTD Module 1 INP 6 Alarm
		49: RTD Module 1 INP 7 Trip
		50: RTD Module 1 INP 7 Alarm
		51: RTD Module 1 INP 8 Trip
		52: RTD Module 1 INP 8 Alarm
		53: RTD Module 2 INP 1 Trip
		54: RTD Module 2 INP 1 Alarm
		55: RTD Module 2 INP 2 Trip
		56: RTD Module 2 INP 2 Alarm
		57: RTD Module 2 INP 3 Trip
		58: RTD Module 2 INP 3 Alarm
		59: RTD Module 2 INP 4 Trip
		60: RTD Module 2 INP 4 Alarm
		61: RTD Module 2 INP 5 Trip
		62: RTD Module 2 INP 5 Alarm
		63: RTD Module 2 INP 6 Trip
		64: RTD Module 2 INP 6 Alarm
		65: RTD Module 2 INP 7 Trip
		66: RTD Module 2 INP 7 Alarm
		67: RTD Module 2 INP 8 Trip
		68: RTD Module 2 INP 8 Alarm
		69: RTD Module 3 INP 1 Trip
		70: RTD Module 3 INP 1 Alarm
		71: RTD Module 3 INP 2 Trip
		72: RTD Module 3 INP 2 Alarm
		73: RTD Module 3 INP 3 Trip
		74: RTD Module 3 INP 3 Alarm
		75: RTD Module 3 INP 4 Trip
		76: RTD Module 3 INP 4 Alarm
		77: RTD Module 3 INP 5 Trip
		78: RTD Module 3 INP 5 Alarm
		79: RTD Module 3 INP 6 Trip
		80: RTD Module 3 INP 6 Alarm
		81: RTD Module 3 INP 7 Trip
		82: RTD Module 3 INP 7 Alarm
		83: RTD Module 3 INP 8 Trip
		84: RTD Module 3 INP 8 Alarm
		85: RTD Module 1 Comm Trip
		86: RTD Module 1 Comm Alarm

TYPE	C TYPE	DESCRIPTION ⁽¹⁾
T27		87: RTD Module 2 Comm Trip
		88: RTD Module 2 Comm Alarm
		89: RTD Module 3 Comm Trip
		90: RTD Module 3 Comm Alarm
		91: RTD Sensor-Failure Trip
		92: RTD Sensor-Failure Alarm
		93: Reserved
		94: All Defaults Loaded
		95: Non-Volatile Memory (NV) Enum Error
		96: NV Numeric Error
		97: NV String Error
		98: NV Event-Record Error
		99: NV I ² t Error
		100: Reserved
		101: Display-Communication Trip
		102: Diagnostic Error
		103: Reserved
		104: Network-Communication Trip
		105: Network-Communication Alarm
		106: Reserved
		107: Reserved
		108: Reserved
		109: Reserved
		110: Reserved
		111: Reserved
		112: Reserved
		113: Reserved
		114: Phase Reverse Alarm
		115: Reserved
		116: Starts per Hour Trip
		117: Starts per Hour Alarm
		118: Reserved
		119: Remote/Network Alarm
		120: Remote/Network Trip
		121: Phase Loss Alarm
		122: Local RTD Trip
		123: Local RTD Alarm
		124: Local RTD Sensor Fault
		125: Local RTD Sensor Alarm
		126: I ² t Inhibit Trip
		127: I ² t Inhibit Alarm
		128: Differential Communication Trip
		129: Differential Communication Alarm
		130: Differential Trip
		131: Differential Alarm
		132: Reduced Overcurrent Trip

TYPE	C TYPE	DESCRIPTION ⁽¹⁾
		252: ETR Request ⁽²⁾
		253: Normal Start ⁽²⁾
		254: Incomplete Start ⁽²⁾
		255: No Trip or Alarm Code ⁽²⁾
T31	char	RTC ASCII-Character Setting String: YY/MM/DD HH:mm:SS YY: 2-digit Year (Year 2000 – 2099) MM: Month 1-12 DD: Day 1-31 HH: Hour 0-23 mm: Minute 0-59 SS: Seconds 0-59 RTC is updated when "Set RTC" command is issued
T32	Short	Free Record Pointer Subtract to obtain last record. Range is 0 to 99.
T33	short	Thermal-Model Type 0: NEMA (Max RMS) 1: K-Factor
T38	short	I ² t Reset Type 0: Normal 1: Autoreset 2: Multiple-Motor Sequence
T42	short	Trip Action 0: Disabled 1: Trip1 2: Trip2 3: Trip3 4: Trip1 & Trip2 5: Trip1 & Trip3 6: Trip1 & Trip2 & Trip3 7: Trip2 & Trip3

TYPE	C TYPE	DESCRIPTION ⁽¹⁾
T43	short	Alarm Action
		0: Disabled
		1: Alarm1
		2: Alarm2
		3: Alarm3
		4: Alarm1 & Alarm2
		5: Alarm1 & Alarm3
		6: Alarm1 & Alarm2 & Alarm3
		7: Alarm2 & Alarm3
T44	short	PGR-6200 Status
		Bit0: 1 = Motor Current Detected
		Bit1: 1 = Motor in Run Mode
		Bit2: 1 = Reduced OC On (ROC:On)
		Bit3: 1 = Motor Current >125%
		Bit4: 1 = ETR On
		Bit5: 1 = PTC Open
		Bit6, Bit7: Spare
		Bit8: 1 = Digital Input Valid
		Bit9: 1 = RY1 Energized
		Bit10: 1 = RY2 Energized
Bit11: 1 = RY3 Energized		
T45	short	Trip/Alarm Message Code Bits ⁽³⁾ 15..0
T46	short	Trip/Alarm Message Code Bits ⁽³⁾ 31..16
T47	short	Trip/Alarm Message Code Bits ⁽³⁾ 47..32
T48	short	Trip/Alarm Message Code Bits ⁽³⁾ 63..48
T49	short	Trip/Alarm Message Code Bits ⁽³⁾ 79..64
T50	short	Trip/Alarm Message Code Bits ⁽³⁾ 95..80
T51	short	Trip/Alarm Message Code Bits ⁽³⁾ 111..96
T52	short	Trip/Alarm Message Code Bits ⁽³⁾ 127..112
T53	Short	Trip/Alarm Message Code Bits ⁽³⁾ 143..128
T60	short	Earth-Fault CT Source
		0: Calculated (3I ₀)
		1: Measured (I _{ct})
T61	short	Digital Input Function
		0: None
		1: Trip
		2: Reset
		3: Program Enable
		4: Reduced OC

TYPE	C TYPE	DESCRIPTION ⁽¹⁾
T62	short	Relay Function
		0: None
		1: Trip1
		2: Trip2
		3: Trip3
		4: Alarm1
		5: Alarm2
		6: Alarm3
		7: Current Detected
		8: Run
		9: Start Inhibit
		10: Trip1 Pulse
		11: Watchdog
		12: Network Run1
13: Reduced OC		
T63	short	Analog Output Parameter
		0: Phase Current
		1: Earth Leakage Measured From CT Input
		2: Earth Leakage Calculated From Phase CT Input
		3: Thermal Capacity
		4: Local RTD
		5: RTD Module Maximum Stator Temperature
		6: RTD Module Maximum Bearing Temperature
		7: RTD Module Maximum Load Temperature
		8: RTD Module Maximum Ambient Temperature
		9: Current Unbalance
		10: Zero Output (4 mA)
		11: Full Scale Output (20 mA)
12: Differential Current		
T64	short	PGR-6200 Command
		0: Reserved
		1: Reserved
		2: Reserved
		3: Reset Trips (does not reset Remote/Network Trip)
		4: Set Real-Time Clock
		5: Clear Data-Logging Records
		6: Clear Trip Counters
		7: Reserved
		8: Clear Running Hours
		9: Emergency Thermal Reset
		10: Reserved
		11: Reserved
		12: Re-enable Temperature Protection
		13: Remote/Network Trip Set
14: Remote/Network Trip Reset		

TYPE	C TYPE	DESCRIPTION ⁽¹⁾
		15: Remote/Network Alarm Set
		16: Remote/Network Alarm Reset
		17: Run1 Set
		18: Run1 Clear
T65	short	Network Communication Type
		0: None
		1: A-B DF1
		2: DeviceNet
		3: Reserved
		4: Modbus RTU
		5: Modbus TCP
		6: Reserved
T66	short	Local Communication Baud Rates
		0: 9,600 bit/s
		1: 19,200 bit/s
		2: 38,400 bit/s
T67	short	Trip and Alarm Summary
		Bit0: 0
		Bit1: 0
		Bit2: 0
		Bit3: 0
		Bit4: Trip1
		Bit5: Trip2
		Bit6: Trip3
		Bit7: Alarm1
		Bit8: Alarm2
		Bit9: Alarm3
		Bit10: 0
		Bit11: 0
		Bit12: 0
		Bit13: 0
		Bit14: 0
		Bit15: 0
T68	short	Local Temperature Sensor
		0: Disabled
		1: RTD Sensor
		2: PTC Sensor
T69	short	Network Baud Rate
		0: TIA 9,600 bit/s
		1: TIA 19,200 bit/s
		2: TIA 38,400 bit/s
		3: DeviceNet 125 kbit/s
		4: DeviceNet 250 kbit/s
		5: DeviceNet 500 kbit/s

TYPE	C TYPE	DESCRIPTION ⁽¹⁾
T70	short	Frequency
		0: 50 Hz
		1: 60 Hz
		2: Variable Frequency
T71	short	User Programmable Indicator Selection
		0: None (LED Off)
		1: Trip1
		2: Trip2
		3: Trip3
		4: Alarm1
		5: Alarm2
		6: Alarm3
		7: Relay1
		8: Relay2
		9: Relay3
		10: Digital Input
		11: Current Detected
		12: Current > 125% FLA
		13: Motor in Run Mode
		14: ETR State
		15: Start Inhibit
		16: Network Run1
17: Net Activity		
18: Reduced OC		
T84		DeviceNet Producing Instance
		0: None
		1: 0x32 Basic Overload
		2: 0x33 Extended Overload
		3: 0x34 Basic Motor Starter
		4: 0x35 Extended Motor Starter1
5: 0x64 User Registers		
T85		DeviceNet Consuming Instance
		0: None
		1: 0x02 Basic Overload
		2: 0x03 Basic Motor Starter

Notes:

- (1) All values are integers unless indicated by "Bit x", where x represents bit location and 0 = LSB.
- (2) Not a trip code. Used by event records to indicate start record type.
- (3) The bit number corresponds to the T27 Message Code. The LSB corresponds to the lower message code in the 16-bit number.

**APPENDIX G
GROUND-FAULT PERFORMANCE TEST**

To meet the requirements of the National Electrical Code (NEC), as applicable, the overall ground-fault-protection system requires a performance test when first installed. A written record of the performance test is to be retained by those in charge of the electrical installation in order to make it available to the authority having jurisdiction. A test record form is provided for recording the date and the final results of the performance tests. The following ground-fault system tests are to be conducted by qualified personnel:

- a) Evaluate the interconnected system in accordance with the overall equipment manufacturer's detailed instructions.
- b) Verify proper location of the ground-fault current transformer. Ensure the cable or bus passes through the ground-fault current transformer window, and that the grounding conductors or shields are not encompassed by the ground-fault current transformer in such a way as to cause ground-fault current to be missed. These checks can be done visually with knowledge of the circuit involved.
- c) Verify that the system is correctly grounded and that alternate ground paths do not exist that bypass the current transformer. High-voltage testers and resistance bridges can be used to determine the existence of alternate ground paths.
- d) Verify proper reaction of the circuit-interrupting device in response to a simulated or controlled ground-fault current. To simulate ground-fault current, use CT-primary current injection. Fig. G.1 shows a test circuit using a POWR-GARD PGT-0400 Ground-Fault Relay Test Unit. The PGT-0400 has a programmable output of 0.5 to 9.9 A for a duration of 0.1 to 9.9 seconds. Set the test current to 15% greater than the PGR-6200 trip setting. Inject the test current through the current-transformer window for at least 2.5 seconds. Verify that the circuit under test has reacted properly. Correct any problems and re-test until the proper reaction is verified.
- e) Record the date and the results of the test on the attached test-record form.

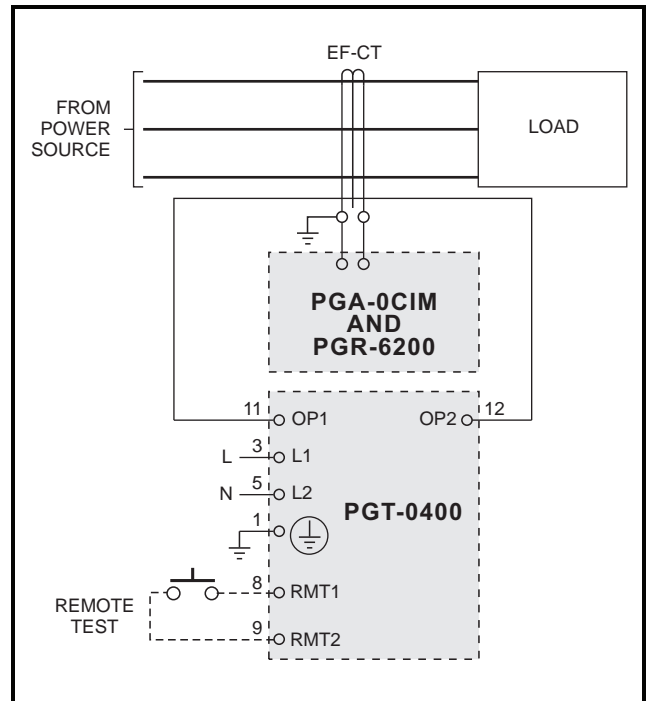

FIGURE G.1 Ground-Fault-Test Circuit.

