

PGR-7200 MANUAL
FEEDER PROTECTION RELAY

May 21, 2010

Revision 1

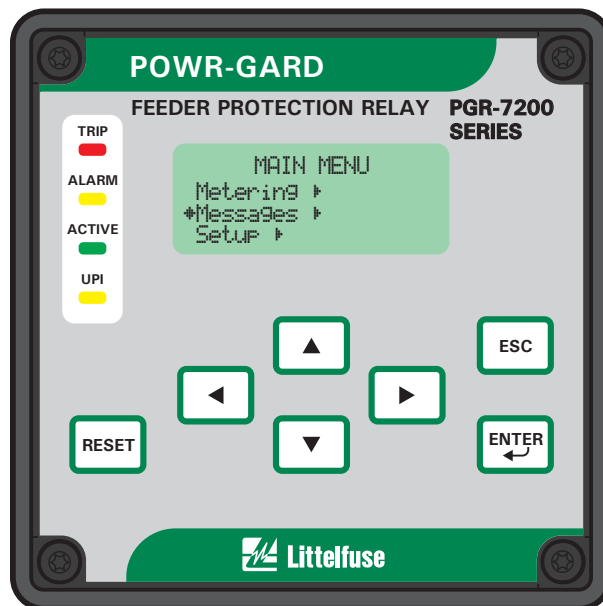

Copyright © 2010 by Littelfuse, Inc.

All rights reserved.

Factory default password is 1111

New Password

See Section 4.5

Feeder Identification

TABLE OF CONTENTS

	<i>Page</i>	<i>Page</i>
Table of Contents.....	i	
List of Figures.....	ii	
List of Tables.....	ii	
1. INTRODUCTION.....	1-1	
1.1 General.....	1-1	
1.2 PGR-7200 Features.....	1-1	
1.2.1 Protection.....	1-1	
1.2.2 Metering.....	1-1	
1.2.3 Data Logging.....	1-1	
1.2.4 Inputs and Outputs.....	1-1	
1.2.5 Operator Interface.....	1-1	
1.2.6 Communications.....	1-1	
1.3 Ordering Information.....	1-3	
2. INSTALLATION.....	2-1	
2.1 General.....	2-1	
2.2 PGR-7200 Feeder Protection Relay.....	2-1	
2.3 PGA-0CIM Current Input Module.....	2-1	
2.4 Sensitive Earth-Fault CT's.....	2-1	
3. SYSTEM WIRING.....	3-1	
3.1 General.....	3-1	
3.2 Wiring Connections.....	3-2	
3.2.1 PGR-7200 Connections.....	3-2	
3.2.1.1 Supply Voltage.....	3-2	
3.2.1.2 CIM Input.....	3-2	
3.2.1.3 Digital Input.....	3-2	
3.2.1.4 Analog Output.....	3-2	
3.2.1.5 PTC or RTD Input.....	3-2	
3.2.1.6 I/O Module Communications.....	3-2	
3.2.1.7 RS/EIA/TIA-232 Communications.....	3-3	
3.2.2 PGA-0CIM Connections.....	3-3	
3.2.2.1 Standard.....	3-4	
3.2.2.2 Residual Earth-Fault.....	3-4	
3.2.2.3 Two-CT.....	3-4	
3.2.3 Cable Restraint.....	3-6	
3.2.4 Dielectric-Strength Testing.....	3-6	
4. OPERATION AND SETUP.....	4-1	
4.1 Display and Indication.....	4-1	
4.1.1 Front-Panel LED Indication.....	4-1	
4.1.2 Rear-Panel LED Indication.....	4-2	
4.1.3 Display Contrast.....	4-2	
4.2 Setup.....	4-2	
4.2.1 Phase-CT Inputs.....	4-2	
4.2.2 Earth-Fault-CT Input.....	4-2	
4.2.3 Frequency.....	4-2	
4.2.4 Set-Point Group.....	4-2	
4.2.5 Output Relay Assignment.....	4-2	
4.2.6 Digital Input.....	4-3	
4.2.7 Analog Output.....	4-3	
4.2.8 Miscellaneous Configuration.....	4-4	
4.2.9 Communications.....	4-4	
4.3 Metering.....	4-4	
4.4 Messages.....	4-4	
4.4.1 Trip Reset.....	4-4	
4.4.2 Data Logging.....	4-5	
4.4.3 Statistical Data.....	4-5	
4.4.4 Emergency Thermal Reset.....	4-5	
4.5 Password Entry and Programming.....	4-5	
5. PROTECTIVE FUNCTIONS.....	5-1	
5.1 General.....	5-1	
5.2 Overload.....	5-1	
5.2.1 I ² t Protection.....	5-1	
5.2.2 Emergency Thermal Reset.....	5-2	
5.3 Inverse-Time Overcurrent.....	5-3	
5.4 Definite-Time Overcurrent.....	5-13	
5.5 Inverse-Time 3I ₀ Earth Fault.....	5-13	
5.6 Definite-Time 3I ₀ Earth Fault.....	5-13	
5.7 Definite-Time Earth Fault.....	5-14	
5.8 Current Unbalance.....	5-14	
5.9 Phase Loss.....	5-14	
5.10 Phase Reverse.....	5-14	
5.11 PTC Temperature.....	5-14	
5.12 RTD Temperature.....	5-15	
6. THEORY OF OPERATION.....	6-1	
6.1 Signal-Processing Algorithms.....	6-1	
7. COMMUNICATIONS.....	7-1	
7.1 Personal-Computer Interface.....	7-1	
7.1.1 Firmware Upgrade.....	7-1	
7.1.2 PGW-COMM.....	7-1	
7.2 Network Interface.....	7-1	
7.2.1 TIA-485 Option.....	7-1	
7.2.2 DeviceNet Option.....	7-1	
7.2.3 Ethernet Option.....	7-1	
8. TECHNICAL SPECIFICATIONS.....	8-1	
8.1 PGR-7200.....	8-1	
8.2 Current Input Module (PGA-0CIM).....	8-2	
Appendix A PGR-7200 Menu Map.....	A-1	
Appendix B PGR-7200 Set-Up Record.....	B-1	
Appendix C PGR-7200 TIA-232 Modbus Protocol.....	C-1	
Appendix D Communications Database Table.....	D-1	
Appendix E Register Formats.....	E-1	
Appendix F Ground-Fault Performance Test.....	F-1	



LIST OF FIGURES

	<i>Page</i>
1.1 Feeder Protection Relay Block Diagram.....	1-2
1.2 PGR-7200 Ordering Information	1-3
2.1 PGR-7200 Outline and Panel-Mounting Details	2-2
2.2 PGR-7200 Outline and Surface-Mounting Details	2-3
2.3 PGA-0CIM Outline and Mounting Details	2-4
2.4 PGC-3026 Outline and Mounting Details.....	2-5
2.5 PGC-3082 Outline and Mounting Details.....	2-6
2.6 PGC-3140 Outline and Mounting Details.....	2-7
3.1 Typical PGR-7200 Connection Diagram.....	3-1
3.2 Analog-Output Connections.....	3-2
3.3 Temperature-Sensor Connections	3-2
3.4 I/O Module Connection Diagram	3-2
3.5 PGA-0CIM Schematic.....	3-3
3.6 PGA-0CIM Standard Connections	3-4
3.7 Other PGA-0CIM Connections	3-5
4.1 Menu Example.....	4-1
4.2 Menu Symbols.....	4-1
5.1 I ² t Overload Cold Curves	5-4
5.2 IEC Normal Inverse, Curve Type A.....	5-5
5.3 IEC Very Inverse, Curve Type B	5-6
5.4 IEC Extreme Inverse, Curve Type C.....	5-7
5.5 IEC Short Inverse, Curve Type A	5-8
5.6 IEC Long Inverse, Curve Type B.....	5-9
5.7 IEEE Moderate Inverse Curves	5-10
5.8 IEEE Very Inverse Curves	5-11
5.9 IEEE Extreme Inverse Curves.....	5-12
5.10 Asymmetrical-Current Multipliers.....	5-13

LIST OF TABLES

	<i>Page</i>
3.1 PGA-0420 Adapter.....	3-3
4.1 UPI LED Functions.....	4-1
4.2 Output-Relay Functions	4-3
4.3 Digital-Input Functions	4-3
4.4 Analog-Output Parameters.....	4-4
4.5 Metering Display.....	4-4
5.1 Curve Types	5-3
5.2 Fault Duration Required for Trip.....	5-13

DISCLAIMER

Specifications are subject to change without notice. Littelfuse, Inc. is not liable for contingent or consequential damages, or for expenses sustained as a result of incorrect application, incorrect adjustment, or a malfunction.

This product has a variety of applications. Those responsible for its application must take the necessary steps to assure that each installation meets all performance and safety requirements including any applicable laws, regulations, codes, and standards.

Information provided by Littelfuse is for purposes of example only. Littelfuse does not assume responsibility for liability for use based upon the examples shown.

1. INTRODUCTION

1.1 General

The POWR-GARD[®] PGR-7200 is a feeder protection relay that provides integrated protection, metering, and data-logging functions. The PGR-7200 can be programmed using the front-panel operator interface, the TIA-232 port, or an optional communications network.

1.2 PGR-7200 Features

1.2.1 Protection

- Overload (49, 51)
- Definite-time overcurrent (50, 51)
- Inverse-time overcurrent (50, 51, IEC and IEEE)
- Definite-time earth fault (50G/N, 51G/N)
- Inverse-time earth fault (50G/N, 51G/N, IEC and IEEE)
- Unbalance (46)
- Phase loss (46)
- Phase reverse (46)
- PTC overtemperature (26, 49)
- RTD temperature (26, 49)
- Two set-point groups

1.2.2 Metering

- Line currents
- Current unbalance
- Positive-sequence current (I_1)
- Negative-sequence current (I_2)
- Zero-sequence current ($3I_0$, calculated)
- Earth-leakage current (CT input)
- Used thermal capacity
- Thermal trend
- RTD temperature

1.2.3 Data Logging

- One-hundred records
 - Date and time of event
 - Event type
 - Cause of trip
 - Line currents
 - Current unbalance
 - Earth-leakage current
 - Used thermal capacity
 - RTD temperature
- Trip counters
- Running hours

1.2.4 Inputs and Outputs

- Phase current inputs
- Earth-leakage-current input
- Programmable digital input (24 Vdc)
- 24-Vdc source for digital input
- 4–20-mA analog output, programmable
- Temperature-sensor input, Pt100 RTD or PTC
- I/O module interface
- Three output relays, programmable
- TIA-232 communications
- Network communications

1.2.5 Operator Interface

- 4 x 20 LCD backlit display
- Display-control and programming keys
- LED status indication

1.2.6 Communications

The standard communications interface is a TIA-232 port using the Modbus[®] RTU protocol. In addition to the standard interface, network communications options include TIA-485 with both Modbus[®] RTU and A-B[®] DF1 protocols, DeviceNet[™], and an IEEE 802.3 port with Modbus[®] TCP Ethernet protocol.

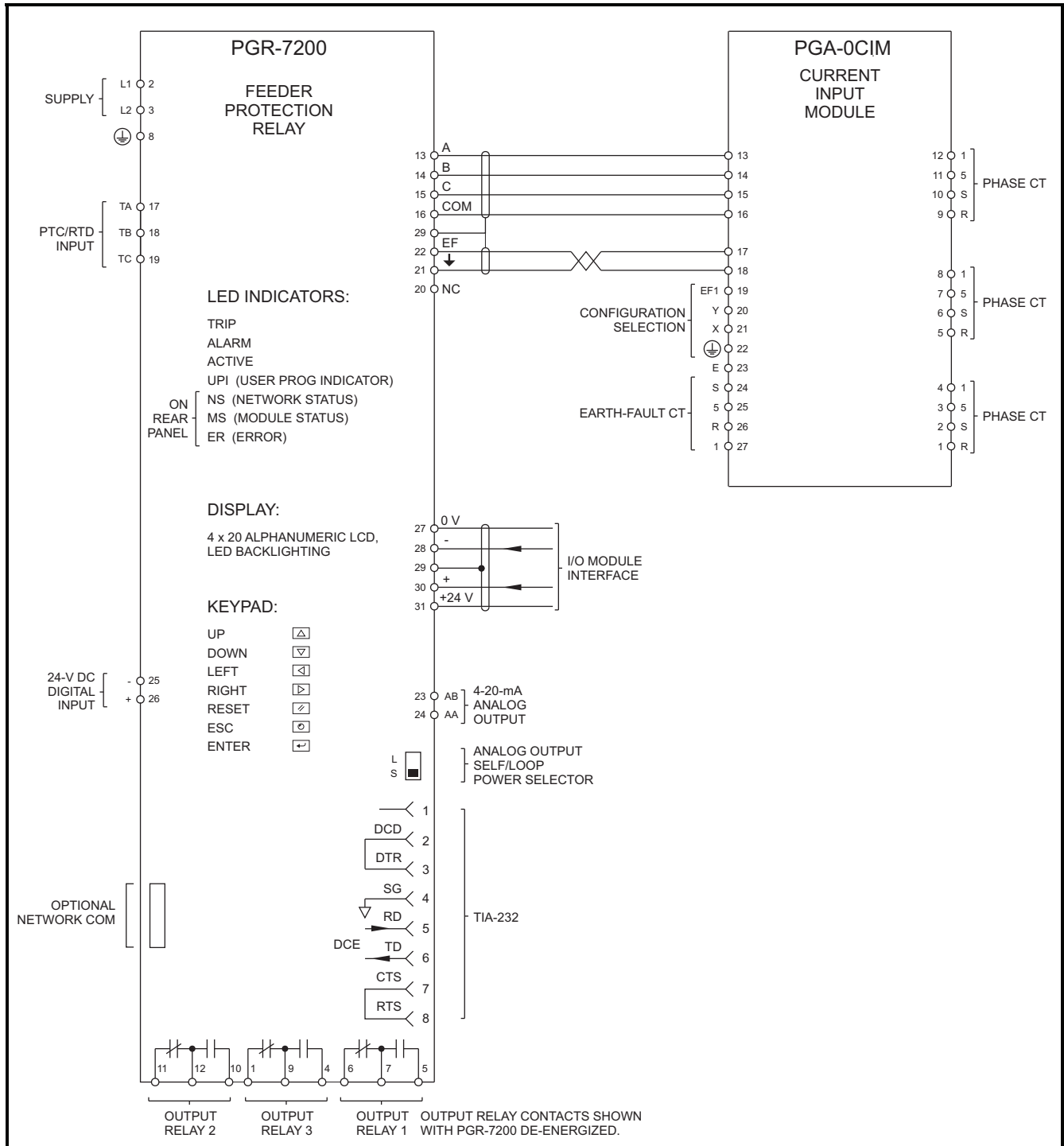

FIGURE 1.1 Feeder Protection Relay Block Diagram.

1.3 Ordering Information

See Fig. 1.2 for PGR-7200 and PGA-0CIM model numbers.

Current Transformers:

- PGC-3026 Sensitive Earth-Fault CT, 5-A-primary rating, 26-mm (1") window
- PGC-3082 Sensitive Earth-Fault CT, 5-A-primary rating, 82-mm (3.2") window
- PGC-31FC Flux Conditioner for PGC-3082, 70-mm (2.7") window
- PGC-3140 Sensitive Earth-Fault CT with Flux Conditioner, 5-A-primary rating, 139-mm (5.5") window

Other Earth-Fault CT's ..Contact factory
Phase CT's.....Contact factory

Accessories:

- PGK-OSMK Surface-mounting hardware kit
- PGA-016A Watertight faceplate cover
- PGA-0420 DB9 to RJ-45 adapter with 1.5-m (5') cable
- PGA-0440 USB to TIA-232 serial converter

Software:

- PGW-COMM PC Interface ⁽¹⁾
- PGW-FLSH..... Firmware Upgrade ⁽¹⁾

⁽¹⁾ Available at www.littelfuse.com/protectionrelays

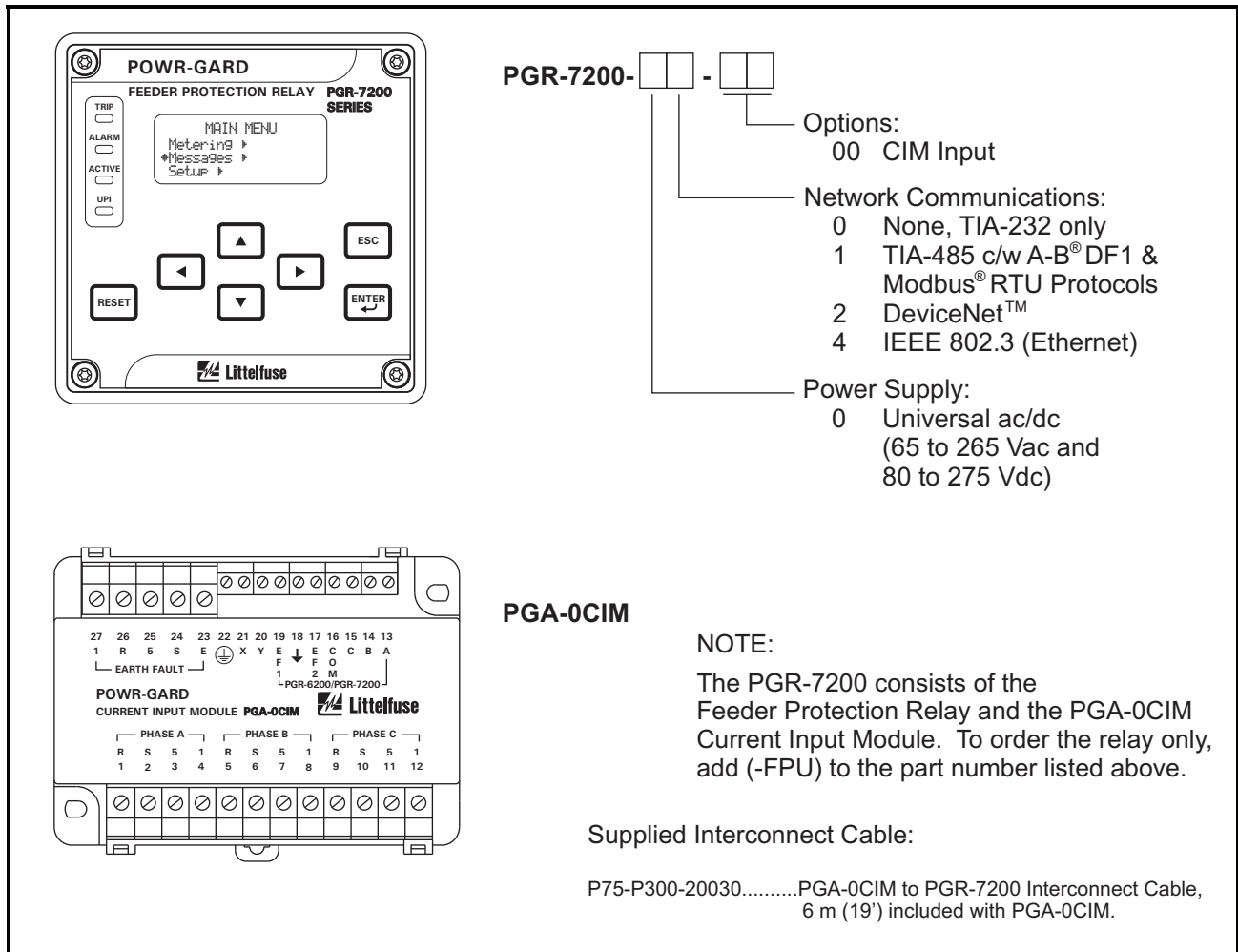

FIGURE 1.2 PGR-7200 Ordering Information.

This page intentionally left blank.

2. INSTALLATION

2.1 General

A basic system consists of a PGR-7200, a PGA-0CIM, and three 1-A- or 5-A-secondary line-current transformers. Earth-fault protection can be provided from a core-balance CT or from phase CT's. A core-balance CT (1-A, 5-A, or PGC-3000 series) is recommended. A single PTC/RTD input is provided on the PGR-7200.

The PGR-7200 switch-mode power supply is rated 65 to 265 Vac and 80 to 275 Vdc.

All modules can be mounted in any orientation.

2.2 PGR-7200 Feeder Protection Relay

Outline and details for PGR-7200 panel-mounting are shown in Fig. 2.1. The PGR-7200 mounts in a 92-mm (3.62") ¼ DIN square cutout and is secured by a panel-mount clamp. Insert the PGR-7200 through the panel cutout and slip the panel-mount clamp over the PGR-7200 body. Slide the clamp forward until the latch tabs snap into the mating holes. Lock the unit in place by tightening the four clamp screws against the panel.

Caution:

Do not over tighten the clamp screws as this may deform the clamp and release the latch tabs.

Outline and details for PGR-7200 surface-mounting are shown in Fig. 2.2. Ensure that the L/S switch is set before installing surface-mounting brackets. See Section 3.2.1.4 for switch positions. A detailed installation instruction sheet is included with the PGK-0SMK Surface-Mounting Hardware Kit.

2.3 PGA-0CIM Current Input Module

The PGA-0CIM can be surface or DIN-rail mounted. Outline and mounting details are shown in Fig. 2.3. To minimize CT-lead burden, a PGA-0CIM can be located close to the CT's. The PGA-0CIM terminates phase- and earth-fault-CT secondaries—shorting blocks are not required for PGA-0CIM outputs.

2.4 Sensitive Earth-Fault CT'S

Outline and mounting details for the PGC-3026, PGC-3082 and PGC-3140 are shown in Figs. 2.4, 2.5 and 2.6.

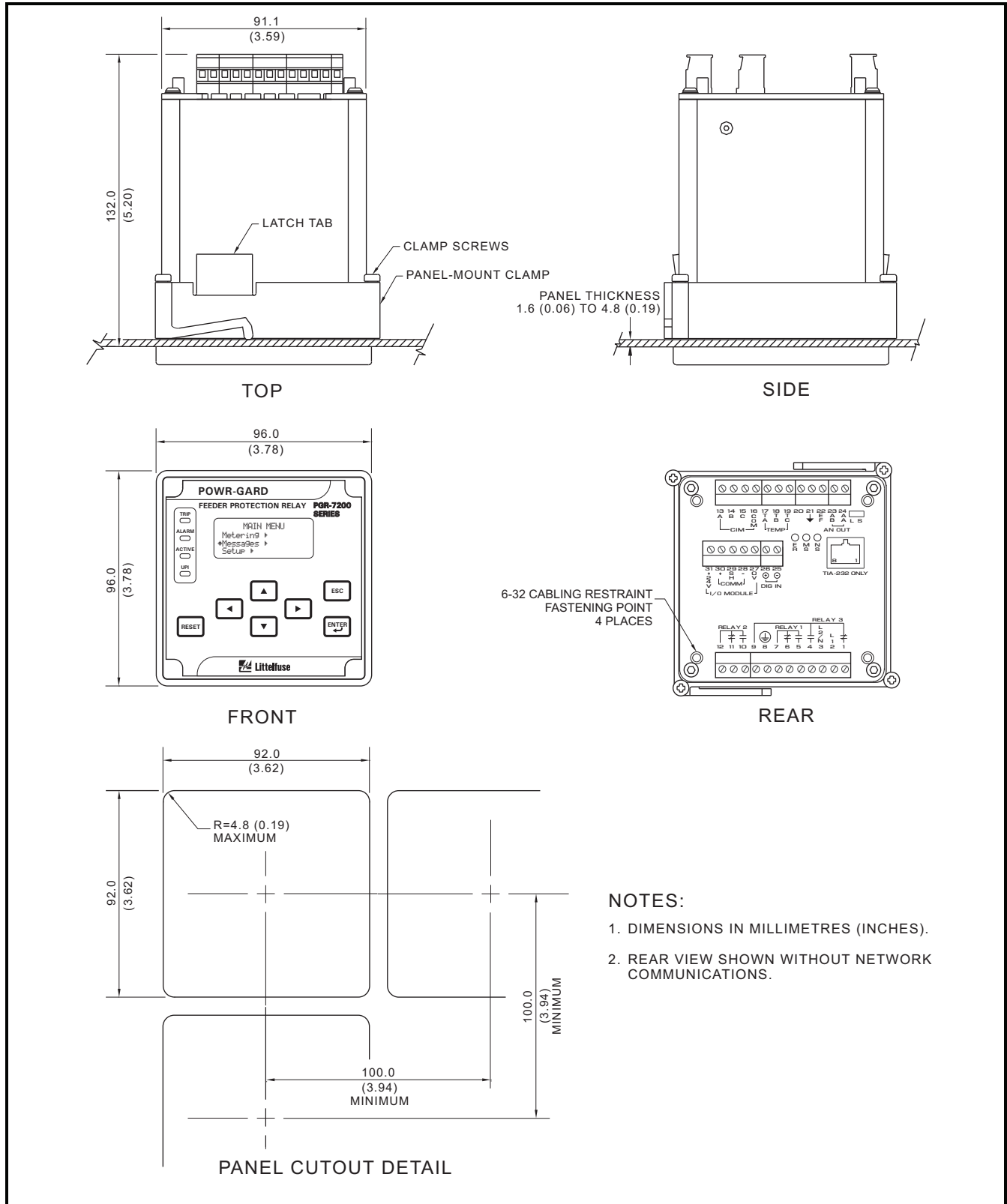

FIGURE 2.1 PGR-7200 Outline and Panel-Mounting Details.

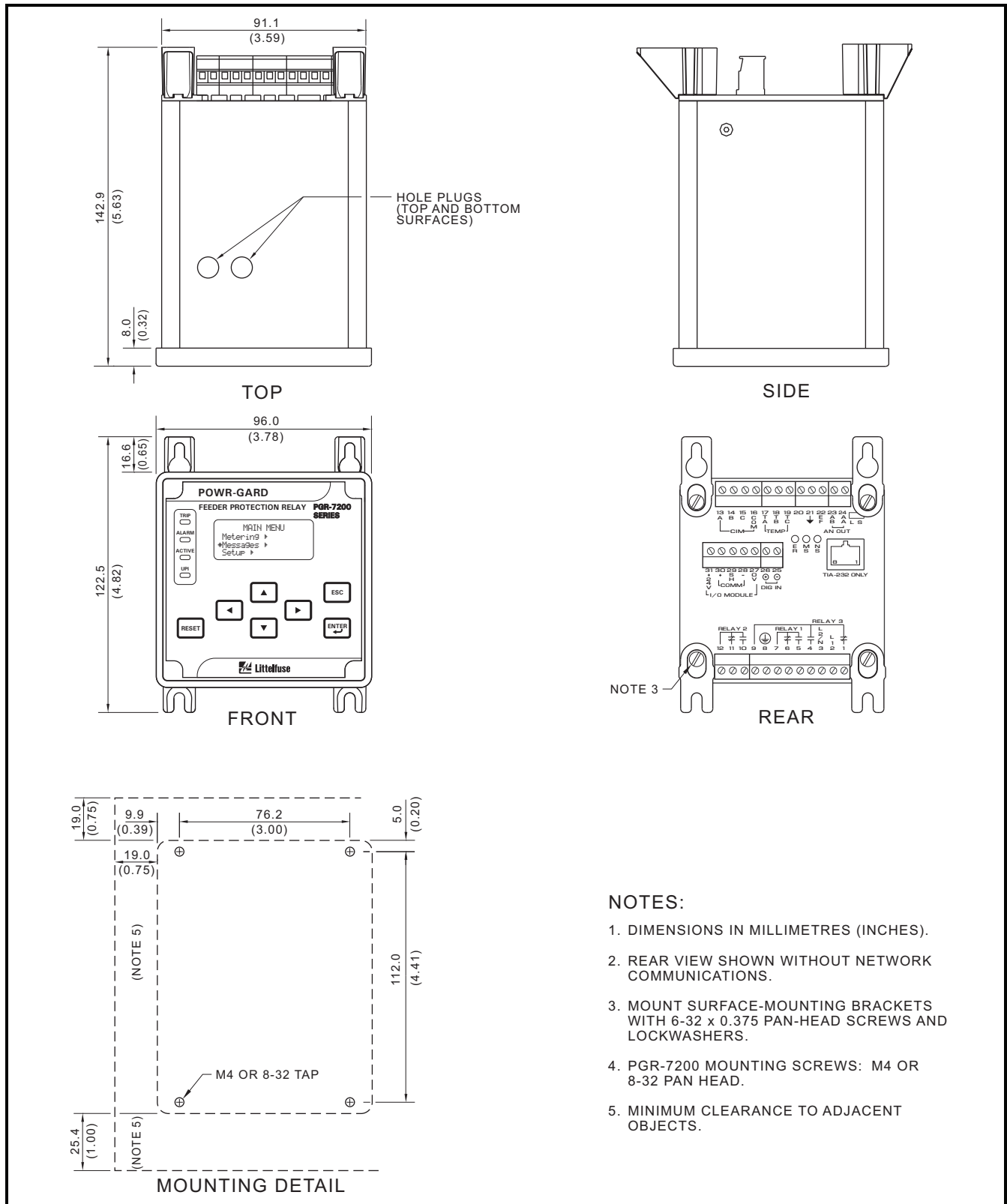

FIGURE 2.2 PGR-7200 Outline and Surface-Mounting Details.

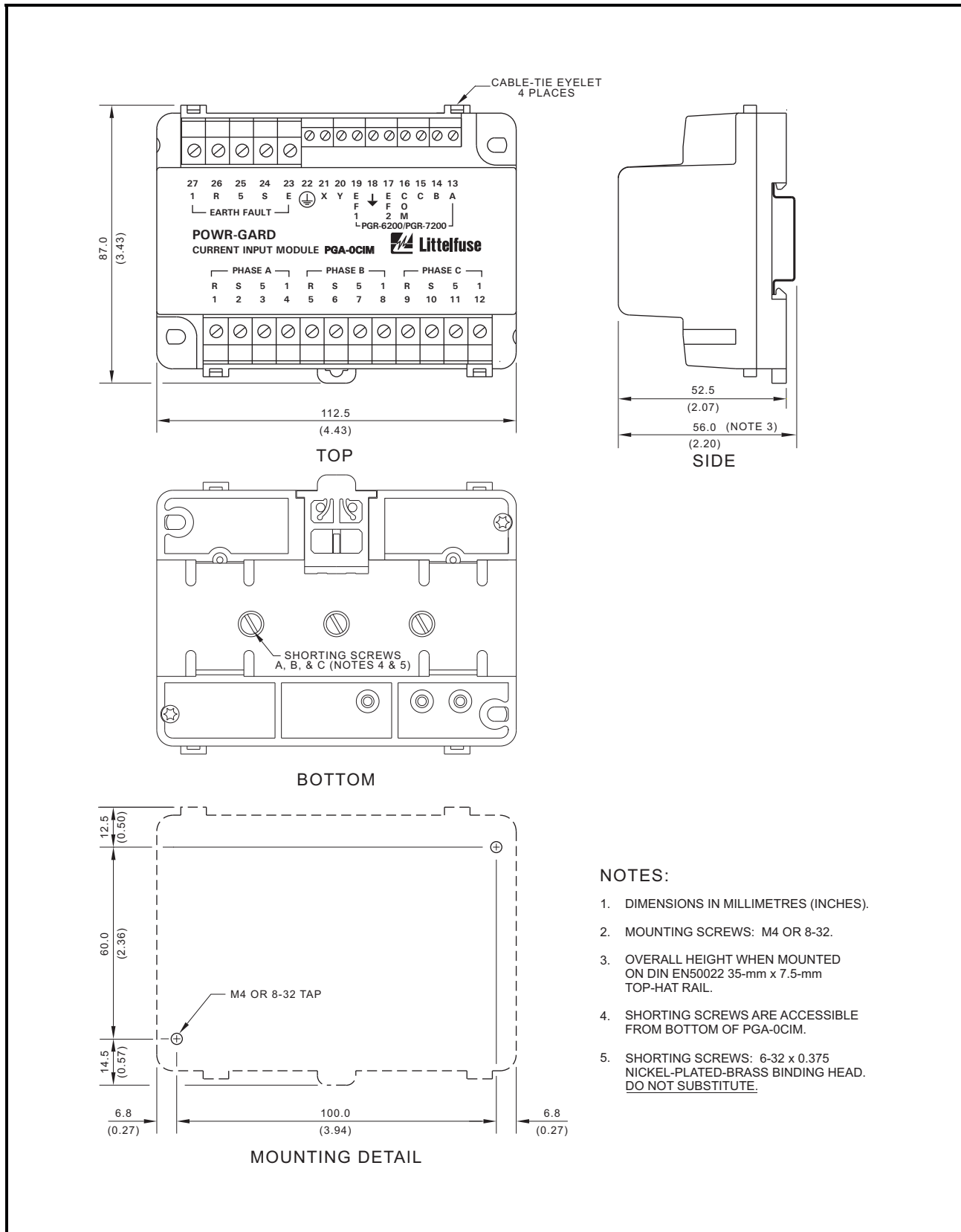

FIGURE 2.3 PGA-0CIM Outline and Mounting Details.

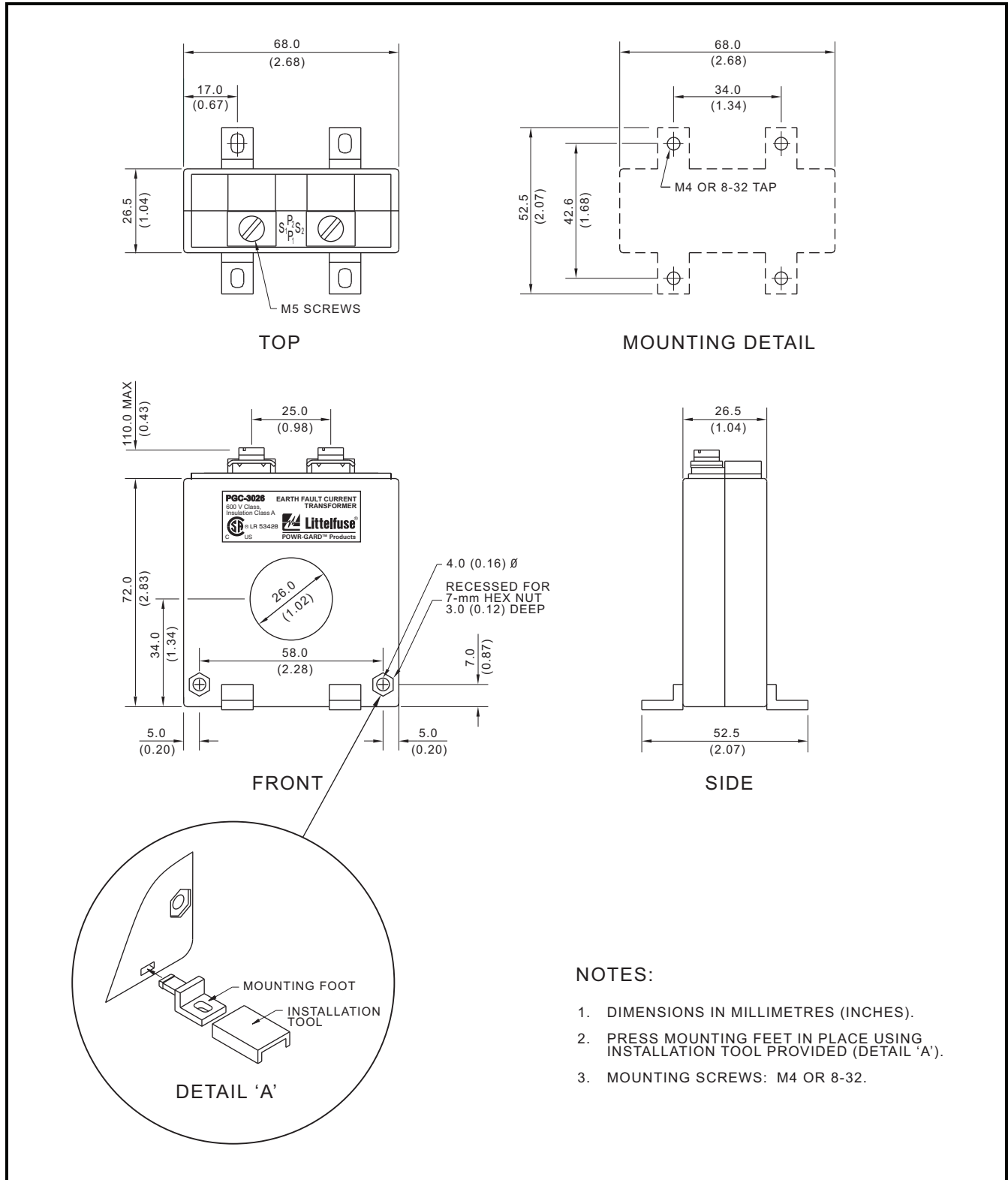

FIGURE 2.4 PGC-3026 Outline and Mounting Details.

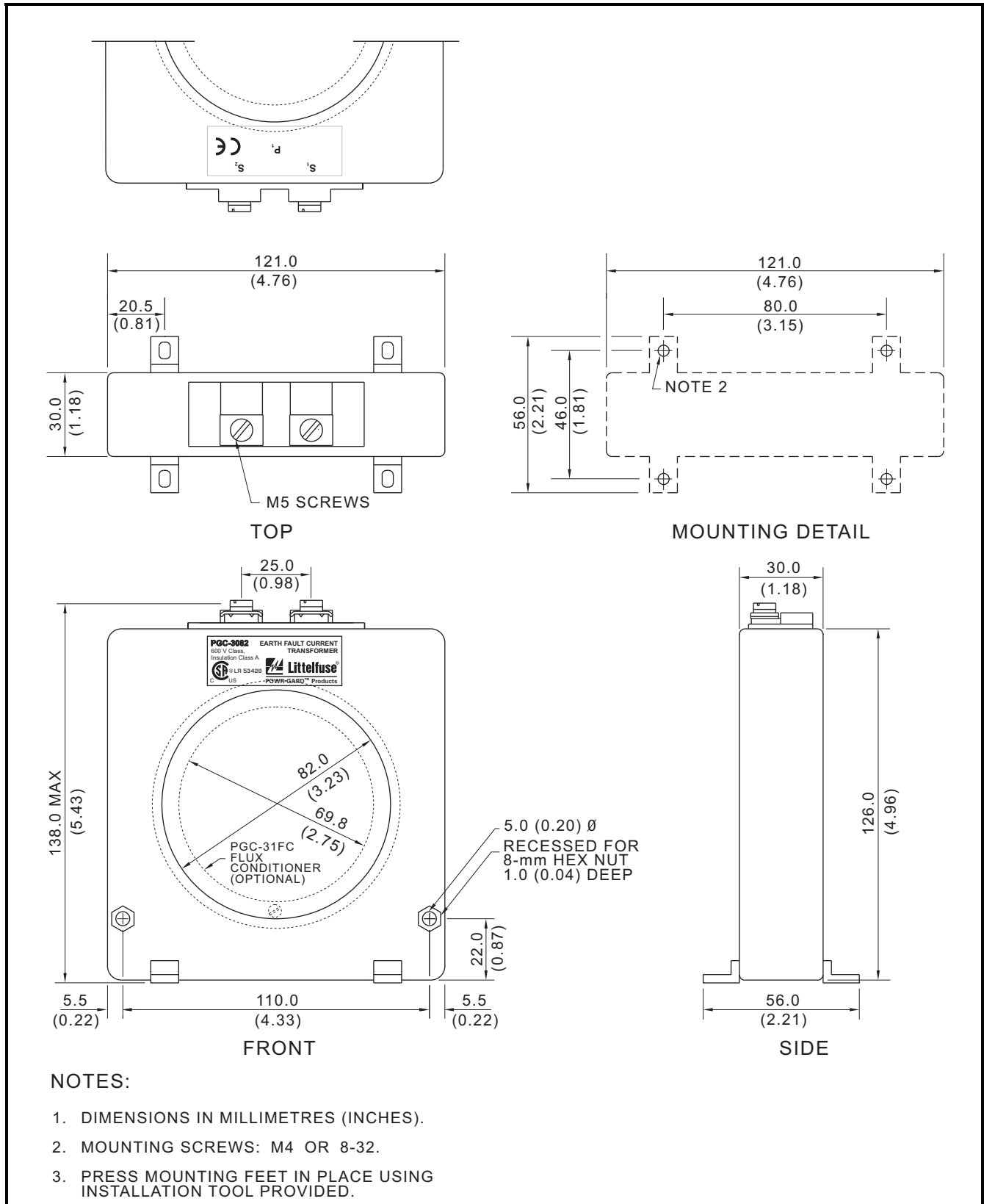

FIGURE 2.5 PGC-3082 Outline and Mounting Details.

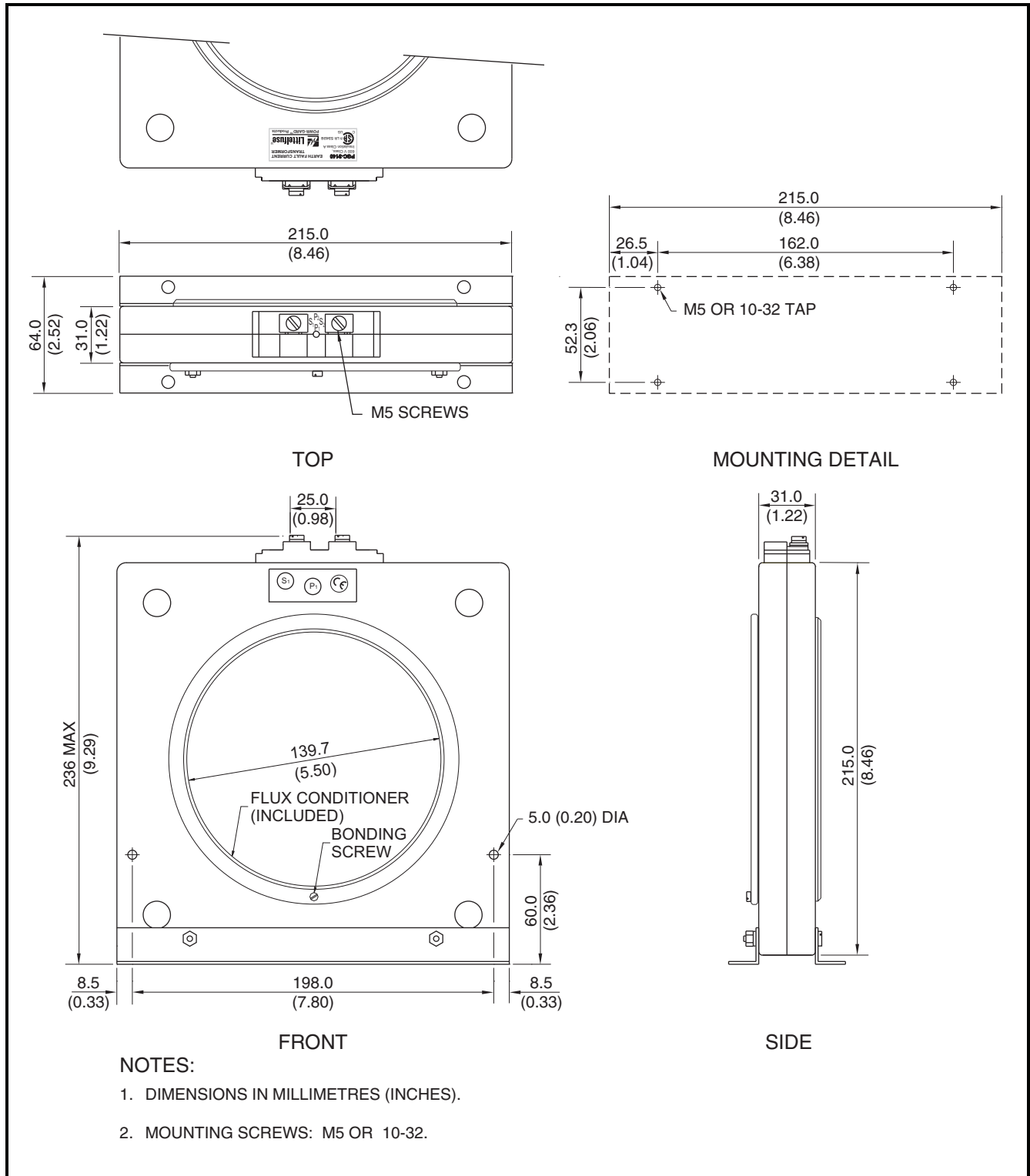

FIGURE 2.6 PGC-3140 Outline and Mounting Details.

This page intentionally left blank.

3. SYSTEM WIRING

3.1 General

A typical connection diagram for the PGR-7200 with the PGA-0CIM is shown in Fig. 3.1.

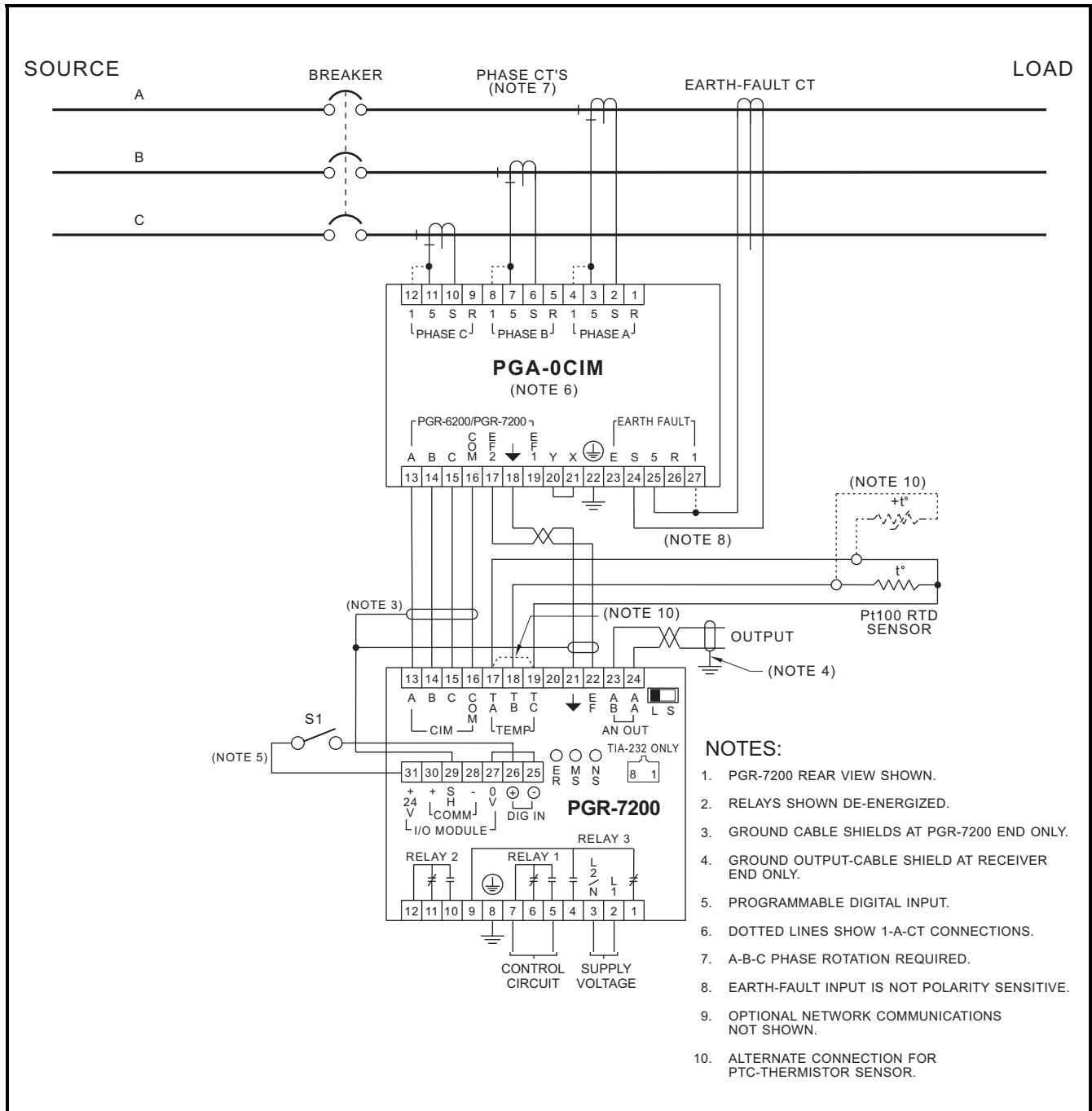

FIGURE 3.1 Typical PGR-7200 Connection Diagram.

3.2 Wiring Connections

3.2.1 PGR-7200 Connections

The PGR-7200 wire-clamping terminal blocks accept 24 to 12 AWG (0.2 to 2.5 mm²) conductors. These terminal blocks unplug to allow the PGR-7200 to be easily replaced.

3.2.1.1 Supply Voltage

Derive supply voltage from the line side of the breaker or from an independent source. Connect supply voltage to terminals 2 and 3 (L1 and L2/N) as shown in Fig. 3.1. In 120-Vac systems, L2/N is designated as the neutral conductor. For direct-current power supplies, use L1 for the positive terminal and L2/N as the negative terminal. Ground terminal 8 (⊕).

3.2.1.2 CIM Input

Connect the PGR-7200 to the PGA-0CIM as shown in Figs. 3.6 and 3.7 using the cable provided with the PGA-0CIM.

3.2.1.3 Digital Input

A 24-Vdc digital input is provided on terminals 25 and 26. This input is polarity sensitive. For a logical 1, terminal 26 must be positive with respect to terminal 25. See Section 4.2.6.

The current-limited 24-Vdc source (terminals 27 & 31) can be used for the digital input.

3.2.1.4 Analog Output

The analog output is switch selectable as self powered or loop powered.

For the self-powered connection, set the L/S switch to the S position. The self-powered connection is shown in Fig. 3.2 (a). The analog output is referenced to the I/O module supply, terminal 27.

For the loop-powered connection, set the L/S switch to the L position. The loop-powered connection is shown in Fig. 3.2 (b). In loop-powered operation, the analog output is isolated from all other PGR-7200 terminals.

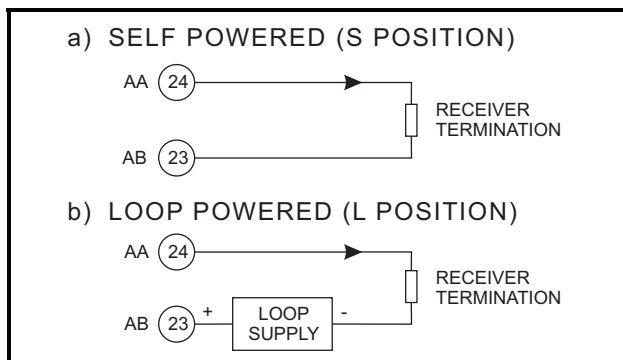

FIGURE 3.2 Analog-Output Connections.

3.2.1.5 PTC or RTD Input

The temperature-sensor input on the PGR-7200 can be configured for either PTC or Pt100 RTD operation as shown in Fig. 3.3.

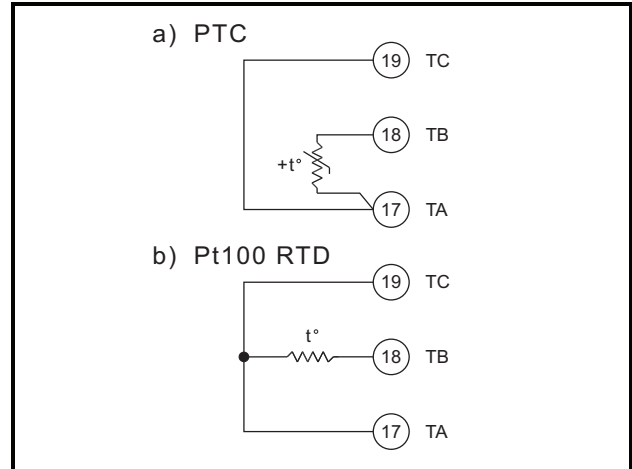

FIGURE 3.3 Temperature-Sensor Connections.

3.2.1.6 I/O Module Communications

The I/O module communications interface is used to support optional modules.

At the publication date, no optional PGR-7200 modules were available. The 24-Vdc supply can be used to power the digital input as outlined in Section 4.2.6.

I/O module communication is based on the two-wire multi-drop TIA-485 standard but uses a proprietary protocol. Overall line length must not exceed 1.2 km (4,000'). For line lengths exceeding 10 m (33'), 150-Ω terminations are required at the cable ends. See Fig. 3.4.

Note: I/O communication is shared with the display. Incorrect wiring can cause the display and keypad to freeze.

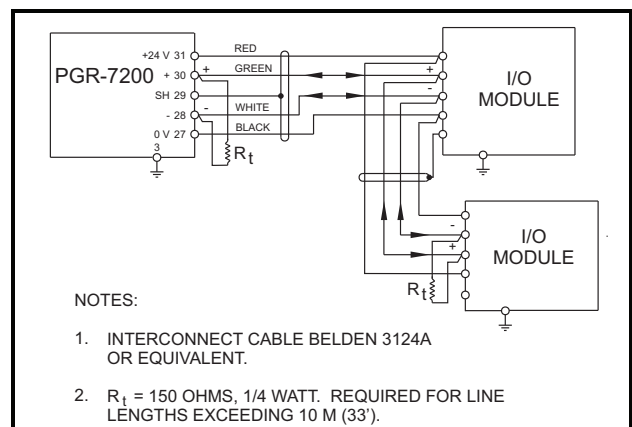

FIGURE 3.4 I/O Module Connection Diagram.

3.2.1.7 RS/EIA/TIA-232 Communications

An RJ-45 TIA-232 connector is provided on the rear panel of the PGR-7200. This port uses the Modbus[®] RTU protocol to communicate with PGW-COMM PC-interface software. For Modbus[®] RTU protocol, see Appendix C. The slave ID and communication baud rate are set in the *Setup | Hardware | Local Comms* menu.

Table 3.1 shows the pinout for the optional PGA-0420 adapter for operation with PGW-COMM. See Fig. 3.1 for RJ-45 pinout. For a USB connection, use a PGA-0440 adapter.

TABLE 3.1 PGA-0420 ADAPTER

NAME	RJ-45	DB9
RI/DSR	1	9
CD	2	1
DTR	3	4
SG	4 ⁽¹⁾	5
RD	5 ⁽¹⁾	2
TD	6 ⁽¹⁾	3
CTS	7	8
RTS	8	7

⁽¹⁾ Minimum requirement for communications.

3.2.2 PGA-0CIM Connections

The PGA-0CIM CT-input terminal blocks accept 22 to 10 AWG (0.3 to 4.0 mm²) conductors. The remaining PGA-0CIM clamping blocks accept 24 to 12 AWG (0.2 to 2.5mm²) conductors.

The PGA-0CIM contains four signal-conditioning interface transformers which are interconnected as shown in Fig. 3.5. These transformers isolate the PGR-7200 from the phase and earth-fault CT's. The PGA-0CIM eliminates the need for CT shorting contacts when the PGR-7200 is disconnected. Phase-CT and earth-fault-CT secondaries can be simultaneously grounded through terminal 22 and a jumper to terminal 20. For applications where the CT secondaries must be grounded at another location, the CT secondaries can be isolated by removing shorting screws A, B, and C through holes in the bottom of the PGA-0CIM. See Figs. 2.3 and 3.5.

Note: A-B-C phase sequence and polarity must be observed when connecting phase CT's. See Section 4.2.1.

Connect the PGA-0CIM to the PGR-7200 as shown in Figs. 3.6 and 3.7 using the cable provided with the PGA-0CIM.

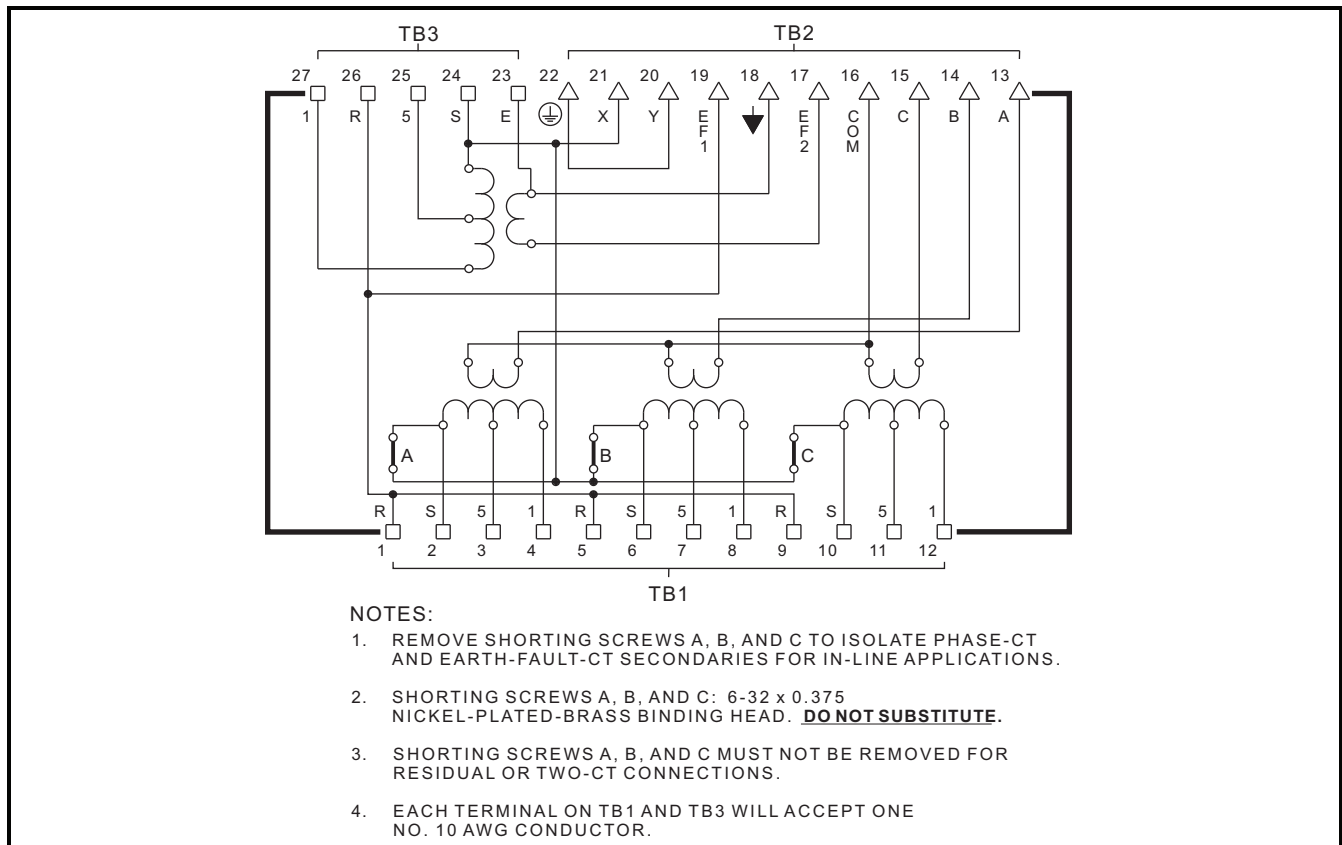

FIGURE 3.5 PGA-0CIM Schematic.

3.2.2.1 Standard

Standard connections with earth-fault CT's are shown in Fig. 3.6. Dotted lines indicate 1-A-CT connections. Use shielded cable for PGC-3000-series connections. Ensure only current-carrying phase conductors pass through the earth-fault-CT window and that ground conductors do not.

3.2.2.2 Residual Earth-Fault

The residual earth-fault connection is shown in Fig. 3.7 (a). Dotted lines indicate 1-A-CT

connections. Use three identical CT's for this connection.

The PGR-7200 also calculates residual current. See Section 4.2.2.

3.2.2.3 Two-CT

The two-CT connection is shown in Figs. 3.7 (b) and 3.7 (c). Dotted lines indicate 1-A-CT connections. Since this connection derives the current in the unmonitored phase, this connection should be used only in retrofit applications where it is not possible to install a third CT.

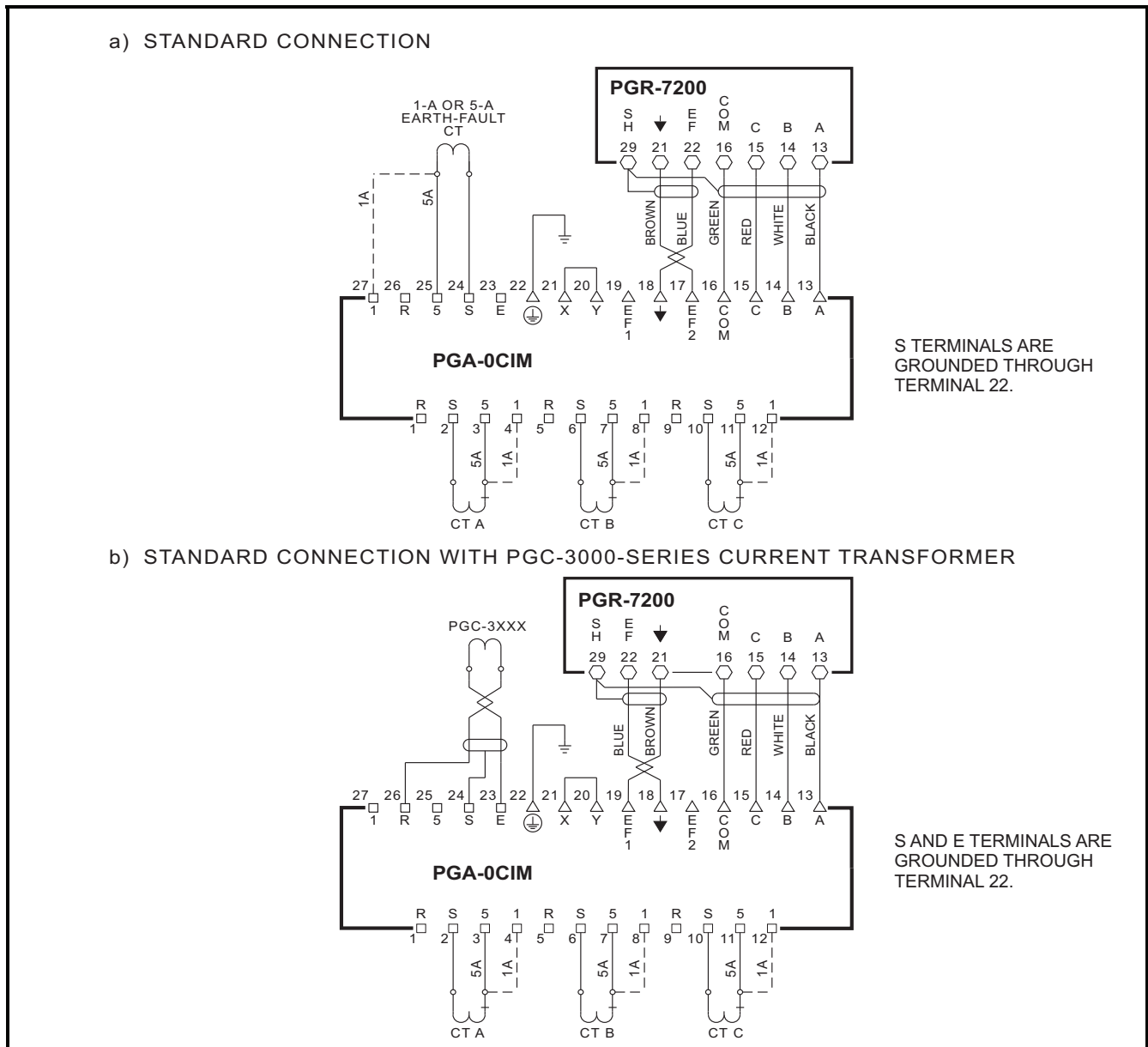
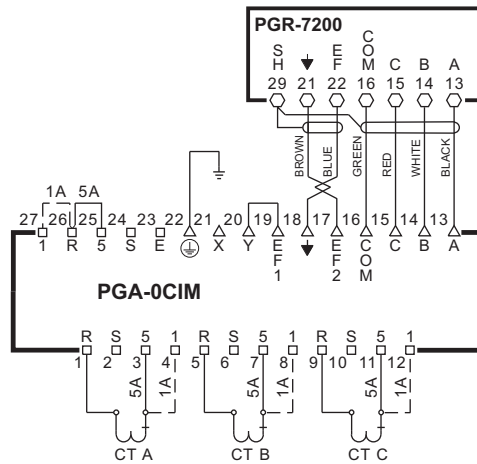

FIGURE 3.6 PGA-0CIM Standard Connections.



a) RESIDUAL CONNECTION



SHORTING SCREWS A, B, & C
MUST NOT BE REMOVED.

R TERMINALS ARE GROUNDED
THROUGH TERMINAL 22.

b) TWO-CT CONNECTION

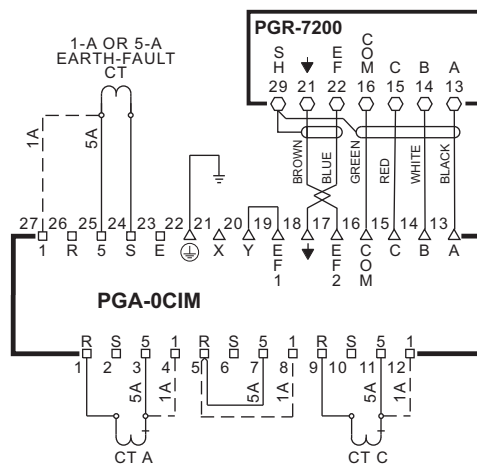

SHORTING SCREWS A, B, & C
MUST NOT BE REMOVED.

R TERMINALS ARE GROUNDED
THROUGH TERMINAL 22.

EARTH-FAULT CT MUST NOT
BE GROUNDED.

c) TWO-CT CONNECTION WITH PGC-3000-SERIES CURRENT TRANSFORMER

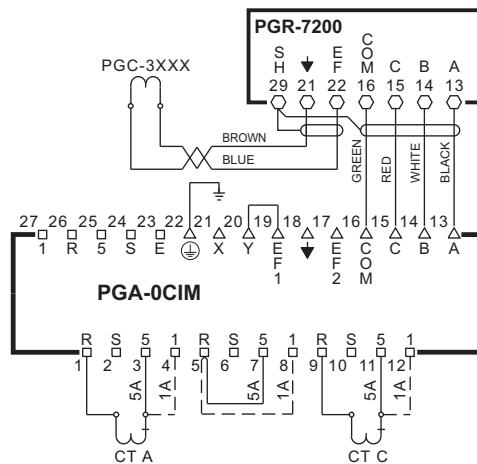

SHORTING SCREWS A, B, & C
MUST NOT BE REMOVED.

R TERMINALS ARE GROUNDED
THROUGH TERMINAL 22.

FIGURE 3.7 Other PGA-0CIM Connections.

3.2.3 Cable Restraint

All conductors should be restrained within 100 mm (4") of the terminal blocks. Four cabling-restraint points are provided on the PGR-7200 rear panel. Secure cables to the PGA-0CIM using the cable-tie eyelets and the cable ties provided. See Figs. 2.1 and 2.3.

3.2.4 Dielectric-Strength Testing

Dielectric-strength testing can be performed only on CT inputs, supply voltage input, and output relays. Unplug all other I/O and remove the PGA-0CIM ⊕ connection (terminal 22) during dielectric-strength testing.

4. OPERATION AND SETUP

4.1 Display and Indication

All PGR-7200 information displays and settings can be accessed using the PGR-7200 menu system, the TIA-232 interface, or a network-communications interface.

In the following sections, menu items and setup parameters are listed in italics and are shown in the format displayed on the alphanumeric LCD. The LCD cannot display subscripts and superscripts.

Menu selection is in the following format:

Menu 1 | Sub Menu 1 | Sub Menu 2 | Sub Menu 3 |.....

Example: For the menu item shown in Fig. 4.1, the notation is *Setup | System Ratings |Phase CT Primary*

Metering ▾		
Messages ▾		
▲ Setup ▾	Protection ▾	
	◆ System Ratings ▾	▼ Phase-CT Primary→
	•	EF-CT Primary→
	•	Frequency→
	•	•
	•	•
	•	•

FIGURE 4.1 Menu Example.

Fig. 4.2 shows the symbols that assist in navigating the menu system and how these symbols

relate to the arrow keys on the PGR-7200. See the PGR-7200 menu map in Appendix A.

4.1.1 Front-Panel LED Indication

Menu: *Setup | System Config | UPI LED*

The red TRIP and yellow ALARM LED's indicate a trip or alarm condition. The green ACTIVE LED is OFF when current is not detected and is ON when current is detected. The yellow UPI LED is a user-programmable indicator and its function is defined by one of the menu selections shown in Table 4.1.

TABLE 4.1 UPI LED Functions

SELECTION	LED ON CONDITION
None	LED remains off.
Trip1	Trip 1 condition exists.
Trip2	Trip 2 condition exists.
Trip3	Trip 3 condition exists.
Alarm1	Alarm 1 condition exists.
Alarm2	Alarm 2 condition exists.
Alarm3	Alarm 3 condition exists.
Relay1	Relay 1 is energized.
Relay2	Relay 2 is energized.
Relay3	Relay 3 is energized.
Digital Input	Digital input is valid.
Current Detected	Current is above 2% CT-primary rating.
3I ₀ Pickup	3I ₀ current exceeds inverse curve pickup value.
Phase Pickup	Phase current exceeds inverse curve pickup value.
ETR	PGR-7200 is in Emergency Thermal Reset state.
Network Run1	Run 1 is issued by a network command.
Net Activity	Activity is detected on the communications interface.

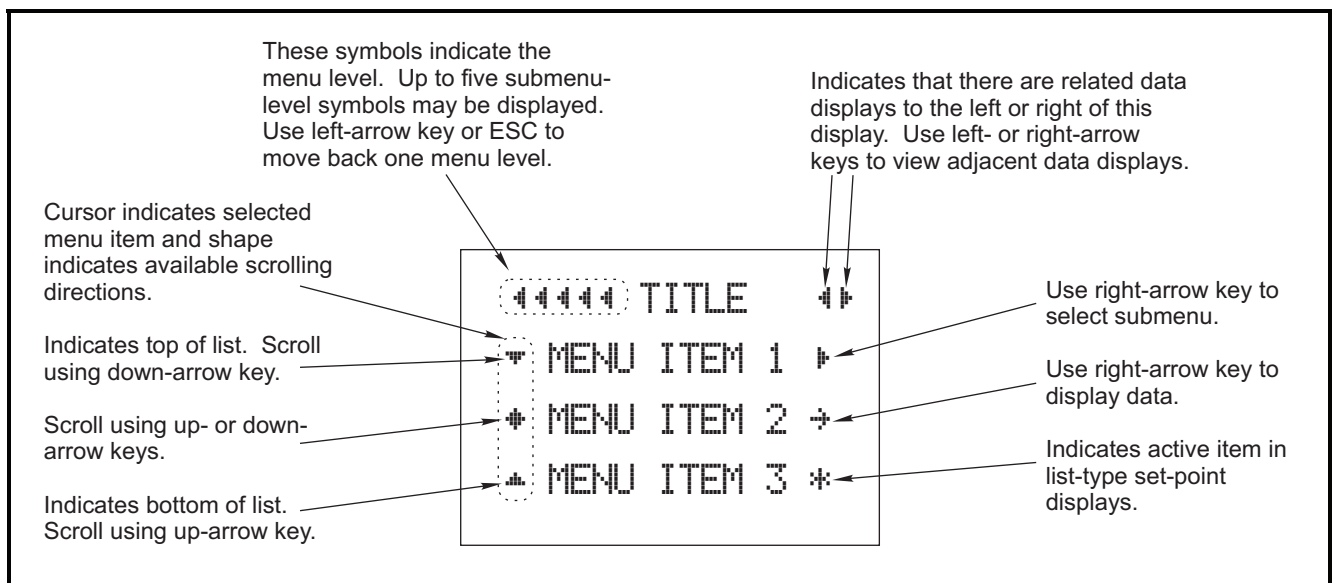

FIGURE 4.2 Menu Symbols.

4.1.2 Rear-Panel LED Indication

The three LED's on the rear panel are labeled ER, MS, and NS. The red ER (Error) LED is OFF during normal operation and is ON when there is a processor error or during firmware-update operation. Output relays are de-energized when this LED is ON. The MS (Module Status) and NS (Network Status) LED's are used for network-communications and firmware-update annunciation. The specific colour and function of these LED's is defined by the network-communications option installed in the PGR-7200. For detailed information, see the applicable communications manual.

4.1.3 Display Contrast







Contrast control and operator-interface test features are available when the display is in Local mode. To prevent a *Display Comm Trip*, select *Disabled* in the *Setup | Hardware | OPI Display | Trip Action* menu. To enter Local mode, press the up-arrow, right-arrow, and ENTER keys simultaneously.

In Local mode, all face-plate LED's are ON and the display indicates three menu items; *Contrast*, *Address*, and *Enter Test Mode*. Use the up- and down-arrow keys to select the menu item.

Contrast: Use the right- and left-arrow keys to increase or decrease contrast.

Address: The display address indicates 1 and cannot be changed.

Enter Test Mode: Press the right-arrow key to enter test mode. In test mode, the LED test, Display test, and Display-Heater test are automatically performed. The Interactive-Key test is then entered and the following symbols are displayed when a key is pressed.

Left Key: 
 Right Key: 
 Up Key: 
 Down Key: 
 ESC: 
 ENTER: 
 RESET: Press RESET to exit this menu.

Press the ESC key to exit Local mode and return to the PGR-7200 menu. Re-enable *OPI Display Trip Action*.

4.2 Setup

Certain PGR-7200 settings cannot be changed when current is detected. See Appendix B.

4.2.1 Phase-CT Inputs

Menu: *Setup | System Ratings | Phase-CT Primary*

The CT-primary setting range is 1 to 5,000 A. To maintain specified accuracy, phase CT's should be

selected with a primary rating between 100 and 300% of rated current.

For A-B-C sequence the +Seq I_1 display value is larger than the -Seq I_2 display value and positive current unbalance is indicated. Negative current unbalance will be indicated if the phase sequence is B-A-C. If negative unbalance is indicated, correct the phase-CT connections. Severe current unbalance may be indicated when phase-CT polarity is incorrect.

4.2.2 Earth-Fault-CT Input

Menu: *Setup | System Ratings | EF-CT Primary*

The earth-fault-CT-primary setting range is 1 to 5,000 A. The EF-CT-primary rating is 5 A for sensitive CT's—PGC-3000-series. *EF-CT Primary* should be set equal to *Phase-CT Primary* for residual CT connections. The protection setting range for the EF-CT connection is equal to the EF-CT-primary rating.

The PGR-7200 also supports earth-fault protection based on the calculated zero-sequence component ($3I_0$). The protection setting range for the $3I_0$ connection is fifteen times the phase-CT-primary rating.

Note: Calculated $3I_0$ does not detect CT saturation. Enable overcurrent protection when earth-fault current can exceed 15 times the phase-CT-primary rating.

4.2.3 Frequency

Menu: *Setup | System Ratings | Frequency*
 Set *Frequency* at 50 or 60 Hz.

4.2.4 Set-Point Group

Menu: *Setup | System Ratings | Set-Point Group*

The PGR-7200 supports two set-point groups. The *Setup | System Ratings | Set-Point Group* menu specifies the active set-point group as Group1 or Group2. If the digital input is used to select the set-point group, it has priority over the menu setting.

4.2.5 Output Relay Assignment

Menu: *Setup | Relay Outputs | Relay x*

Menu: *Setup | Relay Outputs | RY Pulse Time*

Each of the three output relays can be assigned to one of the functions listed in Table 4.2. More than one relay can be assigned the same function. Trip and alarm assignments operate in the selected fail-safe or non-fail-safe mode.

The default assignment for Relay 1 is Trip1, for Relay 2 is Alarm1, and for Relay 3 is None. The default mode setting for all three relays is Fail-Safe.

TABLE 4.2 Output-Relay Functions

FUNCTION	ASSIGNMENT OR ACTION
Trip1	Relay operates when a trip occurs in a protective function assigned Trip1, Trip1&2, Trip1&3, or Trip1,2&3 trip action. Fail-safe or non-fail-safe mode selection is active.
Trip2	Relay operates when a trip occurs in a protective function assigned Trip2, Trip1&2, Trip2&3, or Trip1,2&3 trip action. Fail-safe or non-fail-safe mode selection is active.
Trip3	Relay operates when a trip occurs in a protective function assigned Trip3, Trip1&3, Trip2&3, or Trip1,2&3 trip action. Fail-safe or non-fail-safe mode selection is active.
Alarm1	Relay operates when an alarm occurs in a protective function assigned Alarm1, Alarm1&2, Alarm1&3, or Alarm1,2&3 alarm action. Fail-safe or non-fail-safe mode selection is active.
Alarm2	Relay operates when an alarm occurs in a protective function assigned Alarm2, Alarm1&2, Alarm2&3, or Alarm1,2&3 alarm action. Fail-safe or non-fail-safe mode selection is active.
Alarm3	Relay operates when an alarm occurs in a protective function assigned Alarm3, Alarm1&3, Alarm2&3, or Alarm1,2&3 alarm action. Fail-safe or non-fail-safe mode selection is active.
Current	Relay is energized when current is greater than 2% of CT-primary rating.
Trip 1 Pulse ⁽¹⁾	Trip1 energizes relay for the time duration specified by the <i>RY Pulse Time</i> set point.
Network Run1	Relay is energized by a network "Run1 Set" command and de-energized by a "Run1 Clear" command.
Watchdog	Relay is energized when the PGR-7200 is operating properly.
None	No assignment.

⁽¹⁾ Assign this function to only one relay. Non-fail-safe operation only.

4.2.6 Digital Input

Menu: *Setup | Digital Input | DIN1 Function*

Menu: *Setup | Digital Input | DIN1 Trip Delay*

The digital input can be assigned to one of the functions listed in Table 4.3.

When assigned to the *Trip1* function, the *DIN1 Trip Delay* set point is enabled. A trip occurs if the digital-input voltage is removed for the time specified by the *DIN1 Trip Delay*.

When assigned to *Reset*, trips can be reset using an external reset switch. The *Reset* input is a "one-shot" reset and requires a transition from open to closed. Maintaining a reset switch closure does not inhibit trips.

When assigned to *Program Enable*, the password protection function is disabled and program access is a function of the digital-input state.

When assigned to *Set-Point Group*, one of two groups is selected. The digital-input selection has priority over the *Setup | System Ratings | Set-Point Group* setting.

TABLE 4.3 Digital-Input Functions

FUNCTION	STATE ⁽¹⁾
Trip1	1 = No Trip1 0 = Trip1 (Delay selectable, reset required)
Reset	1 = Reset Trips
Program Enable ⁽²⁾	1 = Program changes allowed 0 = No program changes allowed
Set-Point Group	1 = Group2 Set Points 0 = Group1 Set Points
None	No assignment (Default)

⁽¹⁾ 1 = 24-Vdc applied, 0 = 24-Vdc not applied.

⁽²⁾ Password is disabled.

4.2.7 Analog Output

Menu: *Setup | Analog Output*

The 20-mA analog output can be programmed for one of the parameters shown in Table 4.4.

The analog output is factory calibrated for zero equals 4.0 mA and full scale equals 20.0 mA.

If adjustment is required use the *Analog Output* menus.

Zero Calibration:

- Select *Zero* in the *Output Parameter* menu.
- Measure the output current and adjust the *Zero Calibrate* setting for the desired output. The calibration number for 4 mA will be in the range of 100 to 110.

Full-Scale Calibration:

- Select *Full Scale* in the *Output Parameter* menu.
- Measure the output current and adjust the *FS Calibrate* setting for the desired output. The calibration number for 20 mA will be in the range of 540 to 550.

Calibration numbers are not changed when factory defaults are loaded or during a firmware update.



TABLE 4.4 Analog-Output Parameters

PARAMETER	DESCRIPTION	FULL SCALE
Phase Current	Maximum of the three phase currents.	Phase-CT-primary rating
EF (I_{ct} Measured)	Measured earth-leakage current from EF-CT.	Earth-fault-CT-primary rating
EF ($3I_0$ Calculated)	Calculated earth-leakage current from phase CT's.	Phase-CT-primary rating
Used I^2t	Used thermal capacity.	100% I^2t
RTD Temp	RTD temperature ⁽¹⁾ .	260°C
Unbalance	Current unbalance (I_2/I_1).	1 per unit or 100%
Zero	Zero calibration.	Not applicable
Full Scale	Full-scale calibration.	Not applicable

⁽¹⁾ The output defaults to the calibrated zero output for an open or shorted RTD sensor.

4.2.8 Miscellaneous Configuration

Menu: *Setup | System Config*

- System Name** Appears on many of the display screens and can be set by the user (18-character alphanumeric field).
- Password** Used to change the 4-character alphanumeric password.
- Clock Setting** Used to set the date and 24-hour clock.
- Password Timeout** Used to set the password time-out delay. Delay is measured from last key press.
- UPI LED** Used to assign an internal parameter to the UPI LED.
- Maintenance** Used to clear event records, trip counters, and run hours. Used to load defaults. Used to view firmware version, unit serial number, and MAC address. Used for firmware updates.

4.2.9 Communications

Menu: *Setup | Hardware | TIA-232 Comms*
Menu: *Setup | Hardware | Network Comms*

The TIA-232 interface uses the Modbus® RTU protocol. Set the *TIA-232 ID* and *TIA-232 Baud* to match the requirements of the communications device. Default settings are the same as PGW-COMM PC-interface software defaults.

If equipped with an optional network-communications interface, refer to the appropriate communications-interface manual.

Note: RS-232, EIA-232 and TIA-232 signal specifications are compatible with the PGR-7200.

4.3 Metering

Menu: *Metering*

When *Metering* is selected in the main menu, press the right-arrow key to access a list of metering displays. Use the up- and down-arrow keys to scroll through the display list. Pressing the right-arrow key displays the selected metering information.

RESET is a “hot key” that is active in all meter displays. Pressing RESET causes a jump to the *Trip and Alarm* display to allow trips to be viewed and reset. Pressing ESC or the left-arrow key causes a return to the *Metering* display.

Many displays include per unit (pu) values where 1.0 pu is equal to 100%. I_a , I_b , I_c , I_1 , I_2 , and $3I_0$ are in per unit of phase-CT-primary rating. I_{ct} is in per unit of earth-fault-CT-primary rating.

The unbalance display indicates minus (-) if current inputs are not sequenced A-B-C (negative-sequence current is greater than positive-sequence current).

TABLE 4.5 Metering Display

METERING MENU	INFORMATION DISPLAY ⁽¹⁾
Current	I_a , I_b , I_c in A and per unit of I_b
Unbalance	I_1 , I_2 , in per unit of I_b , I_2/I_1 in per unit
Earth Leakage	I_{ct} in A and per unit of I_e , $3I_0$ in A and per unit of I_b Displays $3I_0 > Pickup$ when current exceeds setting and $3I_0$ protection is selected.
Thermal Status	Used I^2t in percent Trend I^2t in percent Displays “Reset I^2t Trip” when reset is allowed. Displays reset time when tripped on I^2t . Displays time to trip in minutes if in overload.
Inverse Status	Phase and earth currents are less than or greater than inverse-overcurrent pickup.
Local Sensor	Sensor Type: RTD or PTC Displays temperature in °C when type is RTD. Open or Short RTD failure Displays sensor status (Normal, Open, Short) when type is PTC.
I/O Status	Digital input On or Off and relay outputs in binary
System Status	Date and time Settings Group ETR mode
Network Status	Online or timed out Modbus state DeviceNet errors and status

⁽¹⁾ All metering displays show System Name.

4.4 Messages

Menu: *Messages*

Selecting *Messages* allows trip, alarm, and inhibit messages, event records, and statistical data to be viewed and resets to be performed.

4.4.1 Trip Reset

Menu: *Messages | Trip and Alarm*

Up to fifteen trip and alarm messages can be displayed in a scrollable-list format. Trips must be individually selected and reset using the RESET key. All trips are simultaneously reset by a digital-input reset or with a communications-network command. Alarms are non-latching and are displayed only for the time that the alarm condition exists.

RESET is a "hot key" to the *Trip and Alarm* display, except during set-point entry. In the *Trip and Alarm* display, pressing ESC or the left arrow key causes a return to the display shown when RESET was pressed.

4.4.2 Data Logging

Menu: *Messages | Event Records*

Trip-record data and Emergency Thermal Resets (ETR) are logged. Trip-record data includes the time of trip, cause of trip, and pre-trip data. ETR records contain a snapshot of the data prior to an ETR.

Trip- or ETR-records data includes:

- Time Stamp YY/MM/DD HH:MM:SS,
- I_a , I_b , I_c , I_{ct} , and $3I_0$ at time of trip or ETR,
- Unbalance (I_2/I_1) at time of trip or ETR,
- I^2t at time of trip or ETR, and
- PTC/RTD temperature data if applicable.

Each record includes a record number in the first line of the record-data display. The record number is incremented when a new record is generated and has a range from 0 to 65535. When the *Event Records* menu is entered, the first record displayed is the latest record. The right-arrow key scrolls through previous records. Record scrolling stops when the 100th record has been reached or an empty record is displayed.

Event records can be cleared in the *Setup | System Config | Maintenance* menu.

Record Type Trip/ETR
 Number of Records 100 (First In First Out)

4.4.3 Statistical Data

Menu: *Messages | Statistics*

The PGR-7200 records the following statistical data:

- Running hours and
- Counters for each trip type.

Statistical data can be cleared in the *Setup | System Config | Maintenance* menu.

4.4.4 Emergency Thermal Reset

Menu: *Messages | Emerg I²t Reset*

The *Emerg I²t Reset* menu is used to set *Used I²t* to zero. See Section 5.2.2.

4.5 Password Entry and Programming

Menu: *Setup | System Config | Password*

Menu: *Setup | System Config | Password Timeout*

Note: The default password is 1111. When the digital input is programmed for Program Enable, set-point access via the menu system is controlled by the digital input state and not by the password. Set points can always be changed using communications and the password.

When password access is active, all set points are locked from changes until the four-character password is entered. If set-point access is locked, the user is prompted to enter the password. Once entered, set-point access is allowed and remains enabled until a key has not been pressed for the time defined by the *Password Timeout* set point.

Set points are selected either by entering alphanumeric characters or by choosing from a list.

EXAMPLE:

Prior to password entry:

```
I2T PICKUP
= 1.00 x IP
Locked! Press ↵ To
Enter Password.
```

Press ENTER. The *Password Entry* display is shown:

```
PASSWORD ENTRY
Enter Password
And Press ↵
[****]
```

Use the left- and right-arrow keys to select the position of the flashing cursor. Use the up- and down-arrow keys to select password characters. Press ENTER.



When the correct password is entered, a flashing cursor is displayed, the set-point range and units are shown, and the set point can be changed.

```
I2T PICKUP
= 1.00 x IF
(0.10 ÷ 1.25) x IF
[00001.00]
```

Use the up- and down-arrow keys to change a set-point update-field character, and use the left- and right-arrow keys to move between characters. Press ENTER to update the set point, or press ESC to exit the display without changing the set point. A set point is set to the minimum or maximum value of its range if an out-of-range value is entered. Press ESC to exit the set-point-update screen.

The sequence for set-point characters depends upon the set-point type. The character sequence for numeric set points is:

```
. . . 0 1 2 3 4 5 6 7 8 9 . 0 1 2 3 . . . . .
```

The character sequence for string set points is:

```
. . . [0...9] [A...Z] [a...z] SP - . / [0...9] [A...Z] . . . .
```

Characters forming a series are shown in brackets and "SP" represents the space character.

For set points requiring selection from a list, the up- and down-arrow keys are used to scroll through the items. In the same manner as menu items, selections are displayed using one of the three cursor symbols (⤴ ⤵ ⤴) preceding the item. Press ENTER to select the item. The selected item is indicated by the "*" symbol to its right.

EXAMPLE:

```
TRIP ACTION
Disabled          *
⤴Trip 1
Trip 2
```

5. PROTECTIVE FUNCTIONS

5.1 General

The PGR-7200 measures true RMS, peak, and the fundamental-frequency values of current. Fundamental-frequency values (magnitude and phase angle) are obtained by using Discrete-Fourier Transform (DFT) filtering that rejects dc and harmonics. The type of measurement used for a protective function is indicated in each section.

Each protective function can be assigned a trip action that defines the output contact(s) used. Except for overload protection which has auto-reset available, PGR-7200 trips are latched. Trips generate an event record.

Trip-action selections are:

- Disable
- Trip1
- Trip2
- Trip3
- Trip1 and Trip2
- Trip1 and Trip3
- Trip1 and Trip2 and Trip3
- Trip2 and Trip3

Most protection functions can be assigned an alarm action. Alarms are auto-reset and do not generate event records.

Alarm-action selections are:

- Disable
- Alarm1
- Alarm2
- Alarm3
- Alarm1 and Alarm2
- Alarm1 and Alarm3
- Alarm1 and Alarm2 and Alarm3
- Alarm2 and Alarm3

To operate output contacts, trip and alarm actions must be assigned to output relays using the *Setup | Relay Outputs* menu. See Section 4.2.5.

For phase-overcurrent protection, three protection elements are available—overload, inverse time, and definite time. Each can be enabled or disabled as required and are individually annunciated.

IEC and IEEE inverse-time curves are supported. An IEC time multiplier setting range of 0.05 to 1.0 is provided. For consistency, the same multiplier is used for IEEE curves and requires the IEEE characteristic equation to be multiplied by 3. For equations and curves see Fig. 5.1 to Fig. 5.9 in Section 5.3.

For earth-fault protection, inverse-time and definite-time elements are available for the calculated zero-sequence component ($3I_0$). For the earth-fault CT inputs, only definite-time protection is provided. Calculated ($3I_0$) and CT-input protection elements can be enabled simultaneously to provide low- and high-level earth-fault protection in solidly grounded systems.

Phase-overcurrent and ground-fault protection functions have two setting groups; Group 1 and Group 2. Set points are entered for each group and the active group is selected using the menu system, communications, or the digital input. See Section 4.2.6. Group selection allows setting two levels of protection. This is useful in feeder applications where the connected load changes as in tie-breaker systems, or in applications where the feeder is in maintenance mode and operation with reduced trip levels is required.

PGW-COMM PC-interface software can be used to plot PGR-7200 protection curves. See Section 7.1.2.

Note: See Appendix B for default set-point values. Per-unit notation (pu) is used. 1 pu = 100%.

5.2 Overload

5.2.1 I^2t Protection

Menu: *Setup | Protection | Overload*

Unlike IEC and IEEE inverse-time overcurrent protection, the I^2t protection tracks thermal capacity for currents below the pickup setting.

The I^2t protection algorithm uses the square of the maximum phase current as an input.

The cold-curve time-to-trip (t) in seconds for currents above the I^2t Pickup setting is defined by:

$$t = 60 \times \tau \times \ln \left(\frac{I_M^2}{I_M^2 - I} \right)$$

Where :

τ = Time Constant setting in minutes

$$I_M = \frac{I_{MAX-RMS}}{I_{Pickup}}$$

The time constant for overload protection is set in the *Setup | Protection | Overload | Group x | Time Constant* menu. This value is specified in minutes.

From a given curve, the time constant can be determined by knowing the trip time at six times the pickup value (t_6). For this case, the time constant simplifies to:

$$\tau = 0.591 \times t_6$$

Where :

t_6 = Time in seconds at $6 \times$ pickup level

τ = Time Constant setting in minutes

The PGR-7200 provides indication of thermal trend and used thermal capacity. Thermal trend is the value that used thermal capacity is tending toward and it is a function of the square of load current. For currents greater than or equal to the pickup current, time-to-trip is displayed in *Metering | Thermal Capacity*. The thermal trend value (*Trend I²t*) in percent is:

$$\text{Trend } I^2t = I_m^2 \times 100\%$$

For currents less than *I²t Pickup* current, *Trend I²t* in percent is a function of the *Hot Factor* setting given by:

$$\text{Trend } I^2t = I_m^2 \times HF \times 100\%$$

Where :

HF = Hot Factor setting

Selected *I²t* overload cold curves are shown in Fig. 5.1. PGR-7200 *I²t* overload protection is dynamic. Time to trip at any overload current depends on the value of *Used I²t*—as *Used I²t* increases, time to trip decreases. PGR-7200 *I²t* overload cold and warm protection curves can be plotted using PGW-COMM PC-interface software.

An overload trip occurs when *Used I²t* reaches 100%. When an overload trip occurs, reset is not allowed until *Used I²t* falls below the *I²t Reset Level* set point. The time-to-reset in minutes is:

$$t = -\tau \times \text{Cooling Factor} \times \ln(I^2t \text{ Reset Level})$$

Time-to-reset is displayed in *Metering | Thermal Capacity*.

The thermal model has three different reset modes; Normal, Auto, and Rapid. The *I²t*-overload reset mode is set using the *Setup | Protection | Overload | I²t Reset Type* menu, and applies to both set-point groups.

A thermal-overload trip reset is not allowed until *Used I²t* falls below the *I²t Reset Level* setting. In *Normal* mode a reset input is required to reset a trip. *Normal* is the default reset mode.

In *Auto* mode, an *I²t*-overload trip is automatically reset when *Used I²t* falls below the *I²t Reset Level* setting.

In *Rapid* mode, *Used I²t* decreases exponentially with a fixed two-second time constant when current

is not detected. A reset input is required to reset a trip.

Cooling Factor	0.10 to 10.00 x Thermal Time Constant
Time Constant	1.00 to 60.00 minutes
<i>I²t</i> Pickup	0.10 to 1.25 pu of CT-Primary Rating (<i>I_p</i>)
Hot Factor	0.10 to 1.00
<i>I²t</i> Alarm	0.50 to 1.00 pu
<i>I²t</i> Trip	1.00 pu
Protection	Enable/Disable Trip1, 2, 3 Enable/Disable Alarm1, 2, 3
Measurement Method	RMS
Set-Point Groups	Group 1 and Group 2
<i>I²t</i> Reset Level	0.10 to 0.90 pu (Applies to both groups)

5.2.2 Emergency Thermal Reset

Menu: *Messages | Emerg I²t Reset | Reset I²t Memory*

Emergency Thermal Reset (ETR) sets *Used I²t* to 0% and disables PTC and RTD temperature trips. Program access is required. Disabled-temperature protection is indicated by *t° Disabled by ETR* in the *System State* display. If PTC or RTD temperature protection is not enabled, *t° Disabled by ETR* will not be displayed. RTD or PTC trips are reset when ETR is performed regardless of measured temperatures. Temperature protection must be re-enabled in the *Messages | Emerg I²t Reset | Reenable Temp* menu, or by cycling supply voltage. Disabled-temperature protection can be assigned to the user-programmable indication LED. See Section 4.1.1

Temperature alarms and sensor verification remain enabled during ETR.

Caution: Temperature protection is not automatically re-enabled after an Emergency Thermal Reset.

5.3 Inverse-Time Overcurrent

Menu: *Setup | Protection | Phase Inverse*

The PGR-7200 supports the inverse-time curves listed in Table 5.1.

TABLE 5.1 Curve Types

CURVE TYPE	FIGURE
IEC Normal Inverse, Curve Type A	5.2
IEC Very Inverse, Curve Type B	5.3
IEC Extreme Inverse, Curve Type C	5.4
IEC Short Inverse, Curve Type A	5.5
IEC Long Inverse, Curve Type B	5.6
IEEE Moderate Inverse Curves	5.7
IEEE Very Inverse Curves	5.8
IEEE Extreme Inverse Curves	5.9

Note: The IEEE standard equations were derived by taking the average response of a number of IAC and CO relays set to a “time-dial” setting of 5. The PGR-7200 time-multiplier setting of 1.0 corresponds to the IAC/CO “time-dial” setting of 15.

The *Curve* menu is used to select one of the curve shapes listed in Table 5.1. *Pickup* is in per unit of phase-CT rating and specifies the location of the curve’s vertical asymptote ($I_M = I_{DFT}/I_{pickup} = 1$). *Time Multiplier* selects the specific curve within the curve type.

The PGR-7200 uses the same time-multiplier range of 0.05 to 1.0 for both IEC and IEEE curves.

The *Metering | Inverse Status* menu indicates whether current is above or below *Pickup* and the UPI face-plate LED can be programmed to indicate that current is above *Pickup*. See Section 4.1.1.

Curve See Table 5.1
 Pickup 0.10 to 10.00 x CT-Primary Rating (I_p)
 Pickup Curve Threshold ... 1.1 x Pickup setting
 Reset Curve Threshold 0.9 x Pickup setting
 Time Multiplier 0.05 to 1.00
 Protection Enable/Disable Trip1, 2, 3
 Measurement Method DFT c/w CT-saturation compensation
 Set-Point Groups Group 1 and Group 2

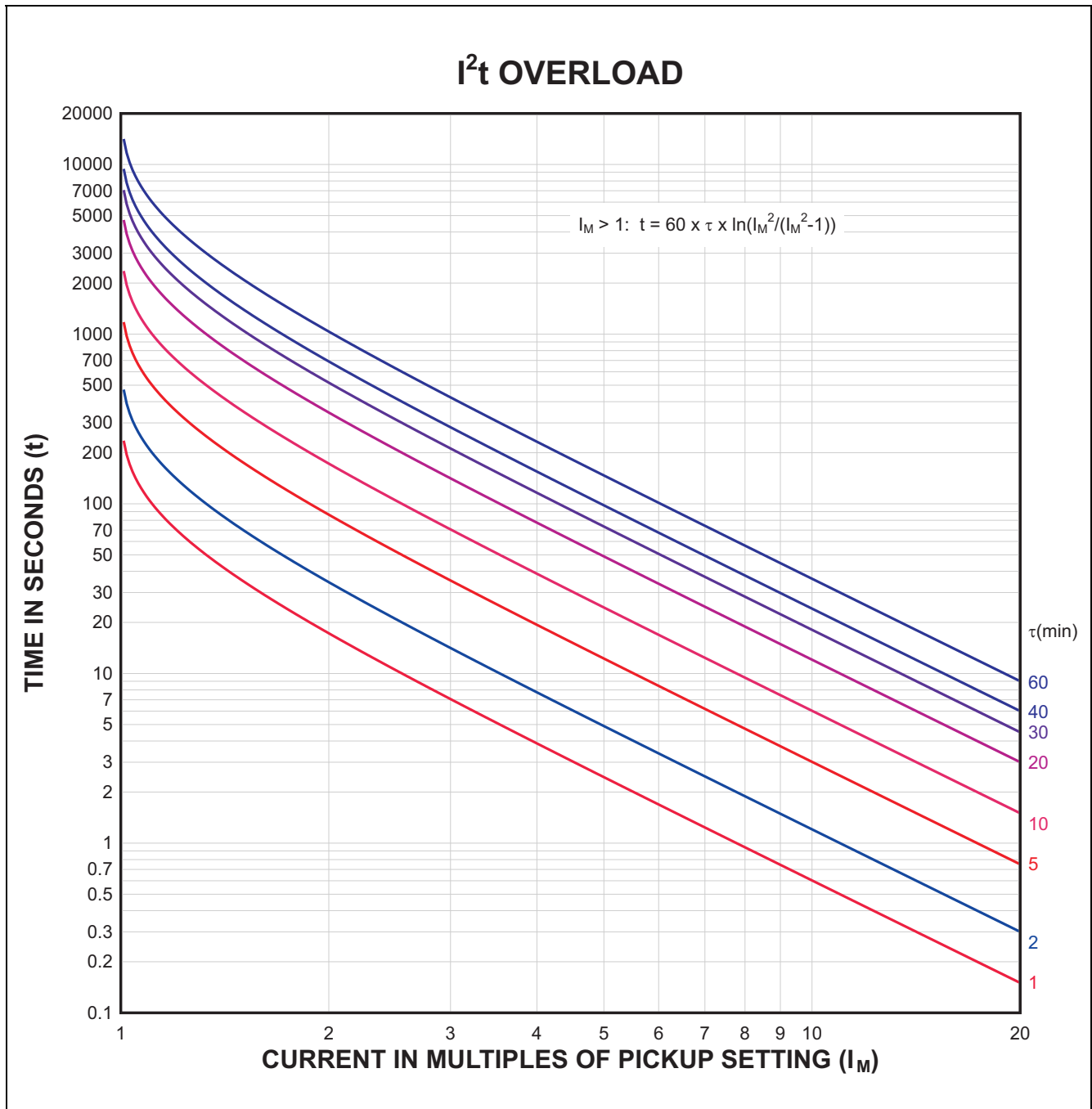

FIGURE 5.1 I²t Overload Cold Curves.

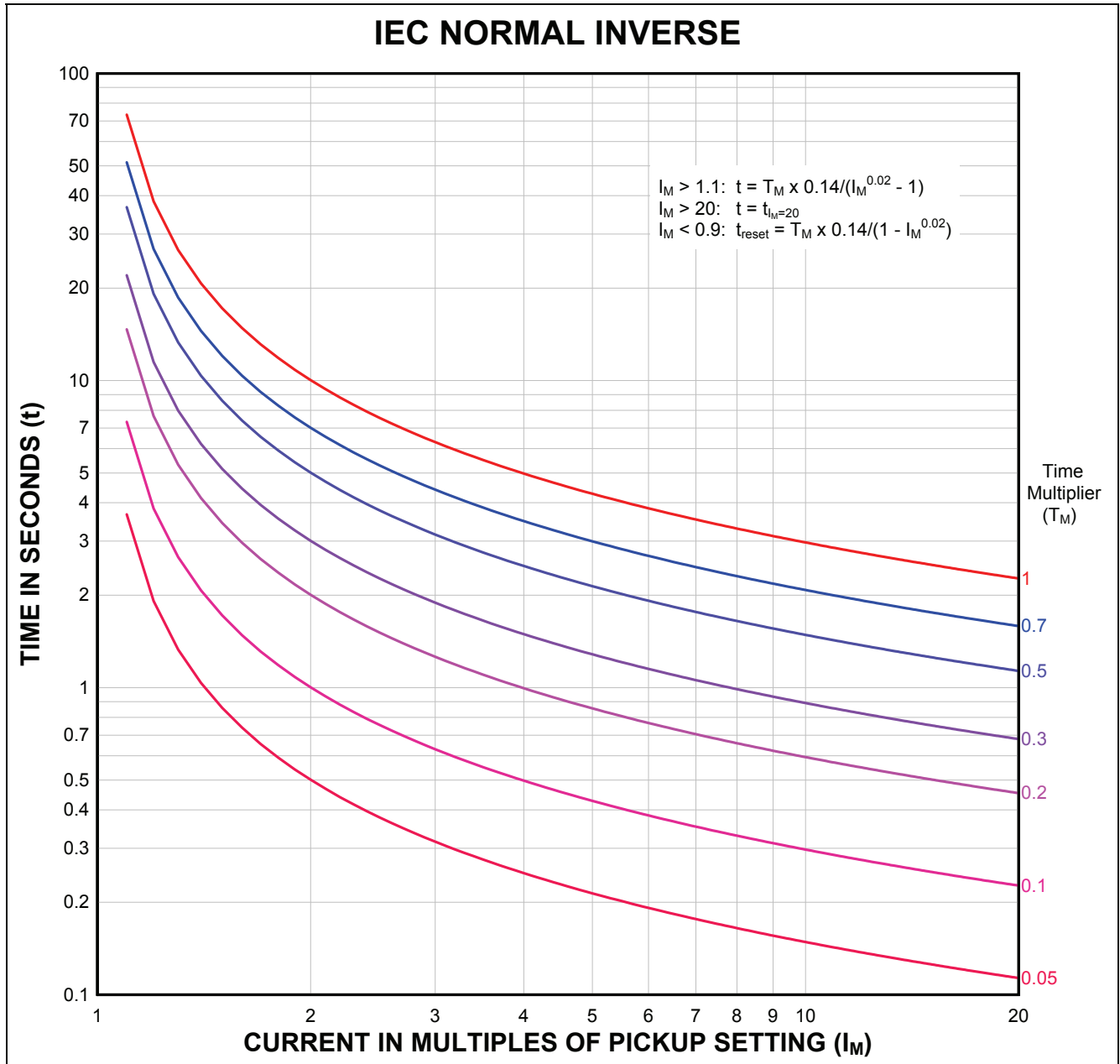

FIGURE 5.2 IEC Normal Inverse, Curve Type A.

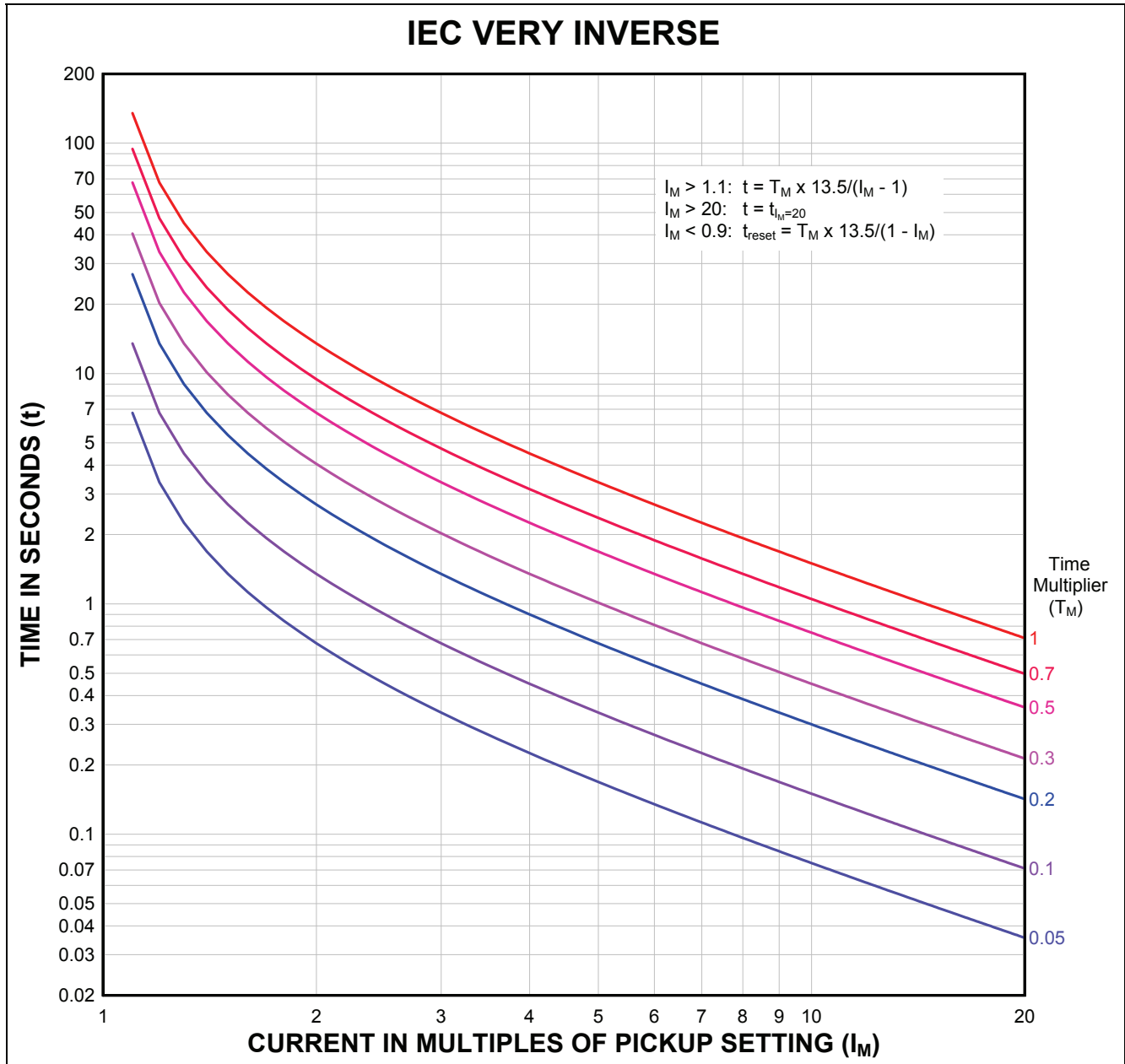

FIGURE 5.3 IEC Very Inverse, Curve Type B.

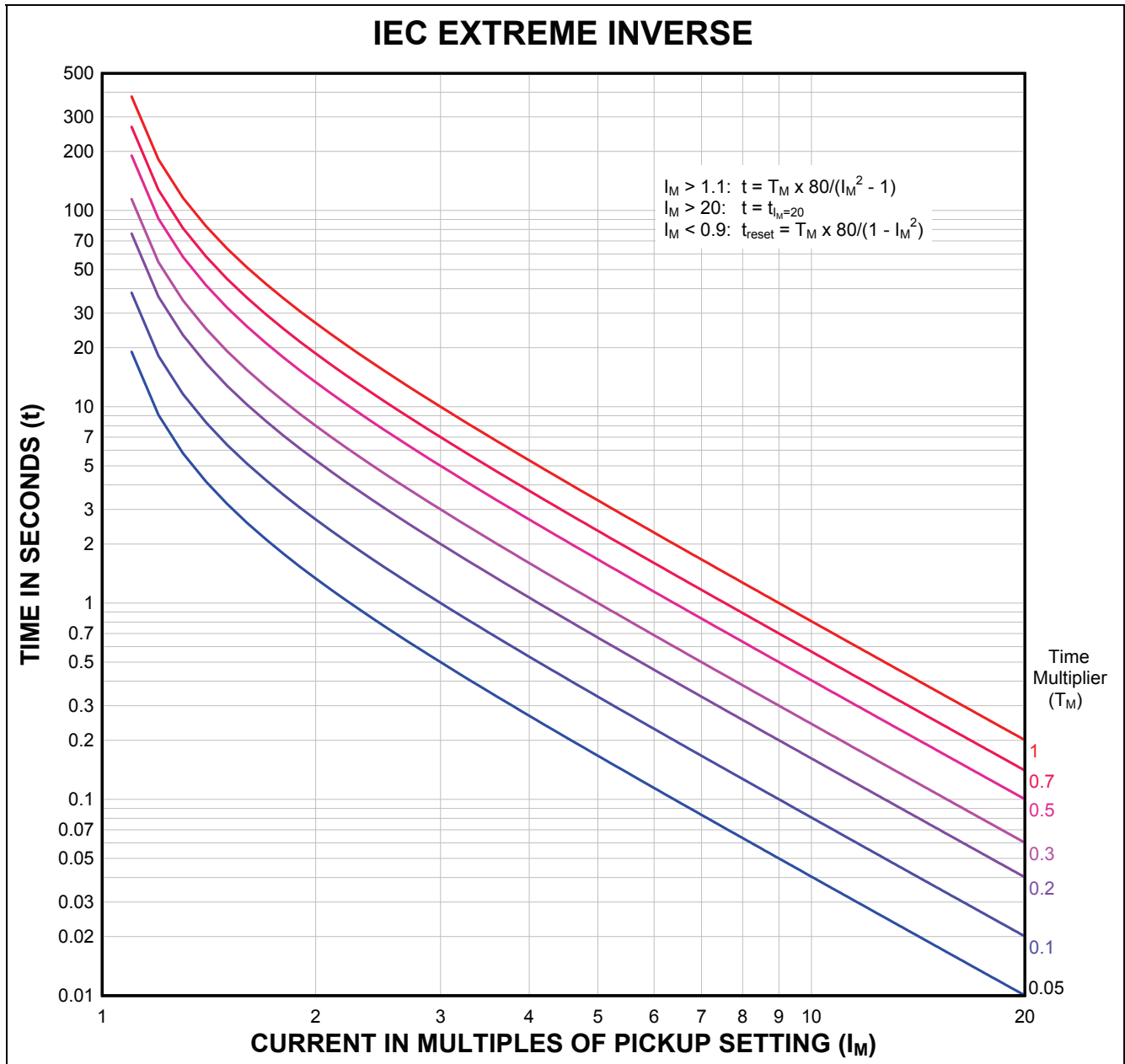

FIGURE 5.4 IEC Extreme Inverse, Curve Type C.

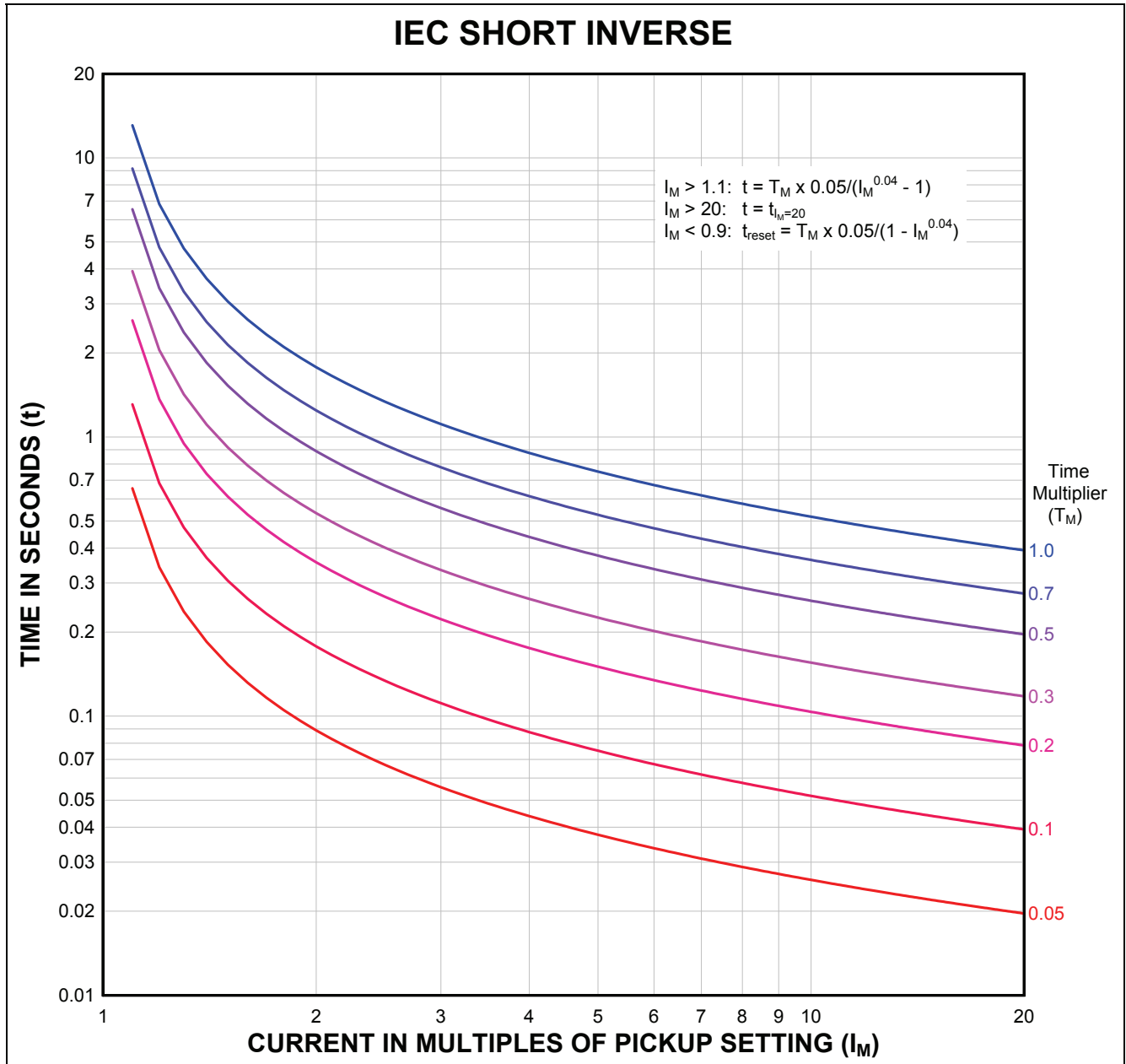

FIGURE 5.5 IEC Short Inverse, Curve Type A.

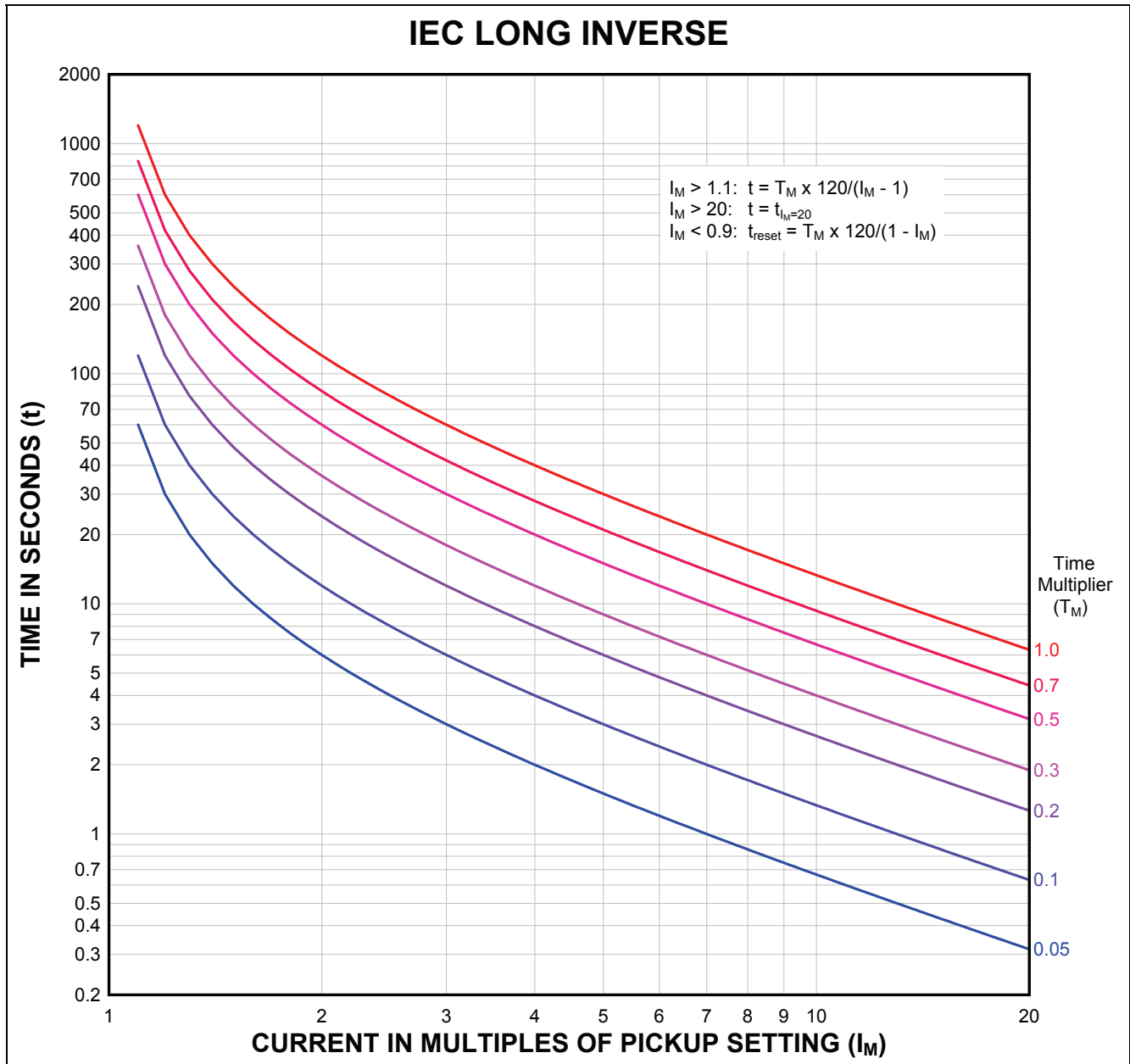

FIGURE 5.6 IEC Long Inverse, Curve Type B.

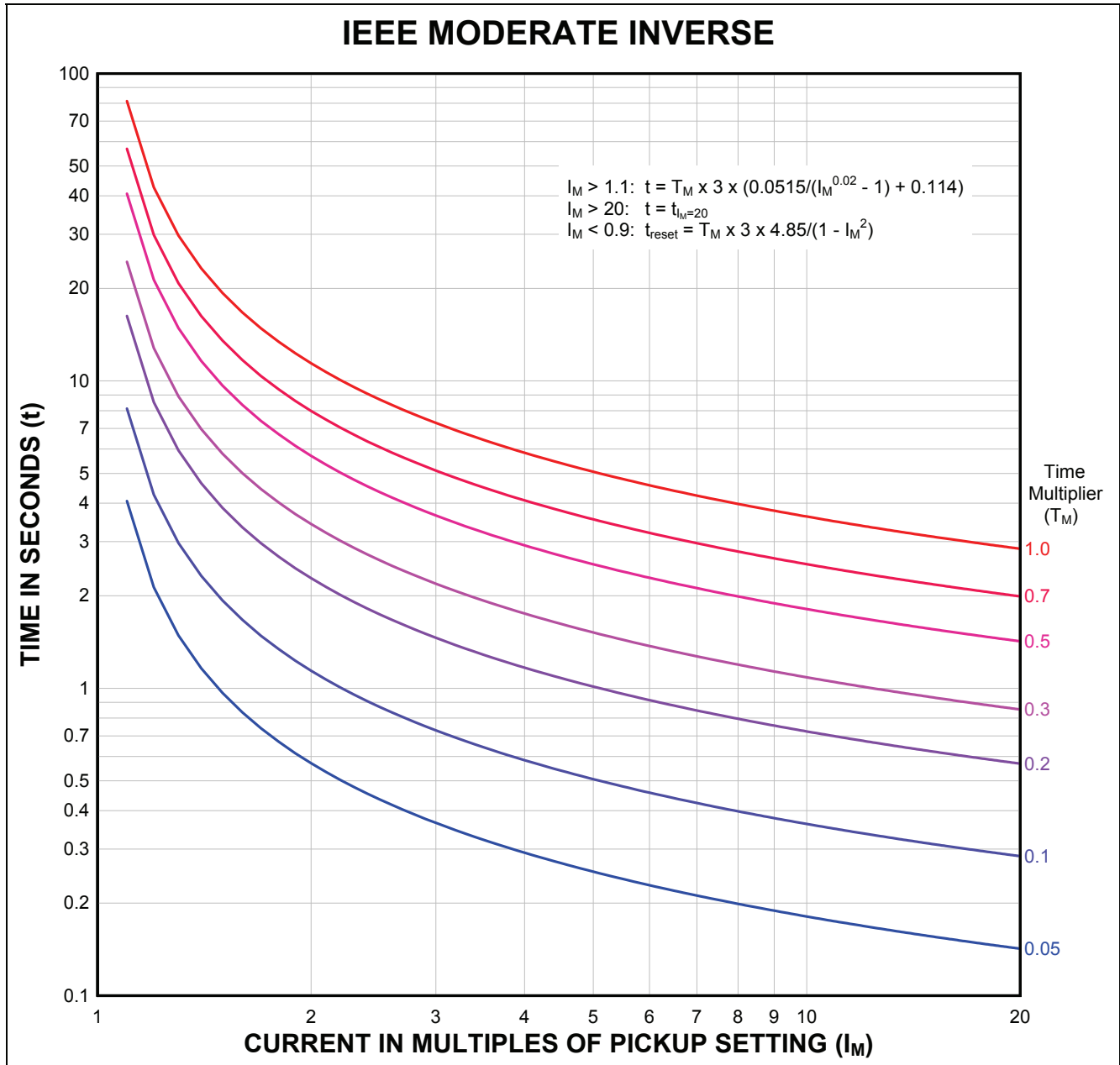

FIGURE 5.7 IEEE Moderate Inverse Curves.

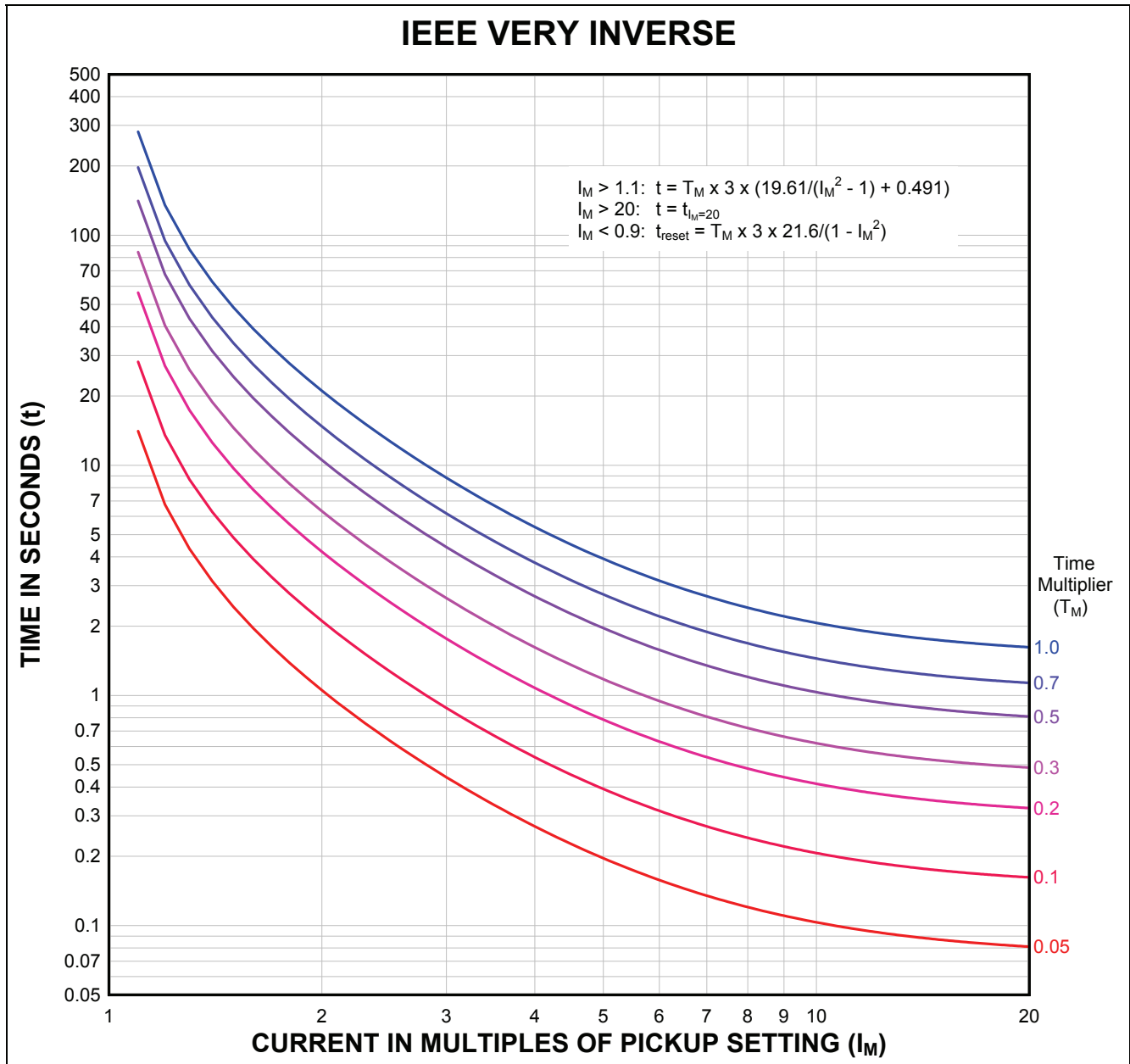

FIGURE 5.8 IEEE Very Inverse Curves.

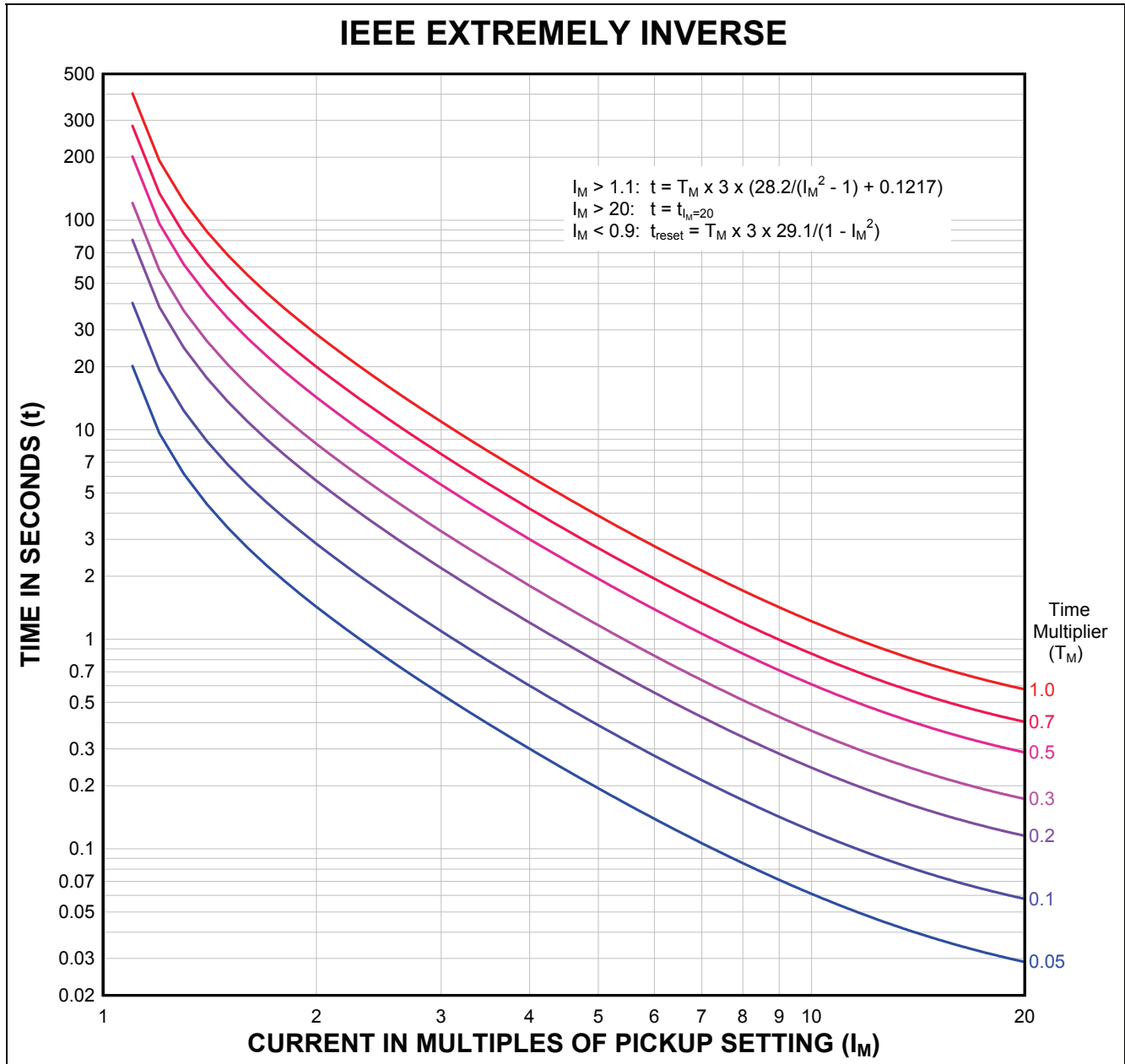

FIGURE 5.9 IEEE Extreme Inverse Curves.

5.4 Definite-Time Overcurrent

Menu: *Setup | Protection | Ph Def Time*

The definite-time overcurrent function has both trip and alarm settings. With the DFT measurement method it may be possible to set the overcurrent protection closer to the desired value as compared to the RMS measurement method.

The asymmetrical-current multipliers for RMS and DFT measuring methods are shown in Fig. 5.10. Typical X/R values are 6.6 for a low-voltage system, 15 for a medium-voltage system, and can be as high as 25 for a high-voltage system. The DFT filters the dc component so that the overcurrent setting can be set closer to the symmetrical fault value.

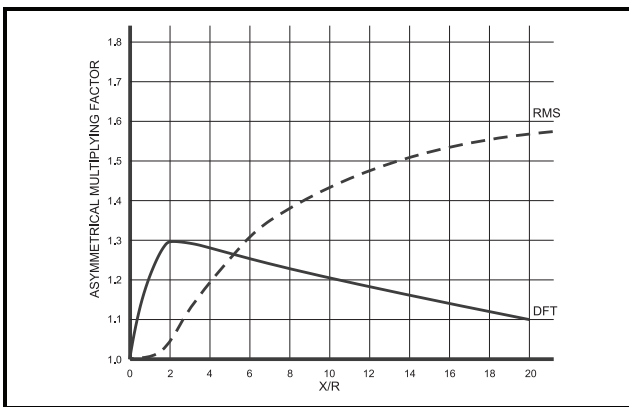

FIGURE 5.10 Asymmetrical-Current Multipliers

- Trip Level..... 0.10 to 15.00 x CT-Primary Rating (I_p)
- Trip Delay (D)..... 0.00 to 10.00 s (see Table 5.2)
- Alarm Level..... 0.10 to 15.00 x I_p
- Alarm Delay (D)..... 0.00 to 10.00 s (see Table 5.2)
- Protection Enable/Disable Trip1, 2, 3
Enable/Disable Alarm1, 2, 3
- Measurement Method DFT c/w CT-saturation compensation
- Set-Point Groups..... Group 1 and Group 2

TABLE 5.2 Fault Duration Required For Trip⁽¹⁾⁽²⁾

FAULT LEVEL (multiples of trip-level setting)	FAULT DURATION (FD) (ms)	
	D ≤ 30 ms ⁽³⁾	D > 30 ms ⁽³⁾
2	FD = 10 ms	FD = (D - 20) ms
5	FD = 5 ms	FD = (D - 25) ms
10	FD = 2 ms	FD = (D - 28) ms

⁽¹⁾ For overcurrent less than 15 x CT-Primary Rating. For earth faults less than 1 x EF-CT-Primary Rating. Fixed frequency, 60 Hz.
⁽²⁾ Minimum relay operating time: 25 to 45 ms.
⁽³⁾ D is the trip-time setting.

5.5 Inverse-Time 3I₀ Earth Fault

Menu: *Setup | Protection | 3I₀ Inverse*

This protection function is based on the zero-sequence current calculated from the three phase currents.

The *Curve* menu is used to select one of the curve shapes listed in Table 5.1. *Pickup* is in per unit of phase CT rating and specifies the location of the curve’s vertical asymptote ($I_M = I_{DFT}/I_{pickup} = 1$). *Time Multiplier* selects the specific curve within the curve type.

The PGR-7200 uses the same time multiplier range of 0.05 to 1.0 for both IEC and IEEE curves.

The *Metering | Inverse Status* menu indicates whether current is above or below *Pickup* and the UPI face-plate LED can be programmed to indicate that current is above *Pickup*. See Section 4.1.1.

- Curve..... Table 5.1
- Pickup..... 0.10 to 10.00 x CT-Primary Rating (I_p)
- Pickup Curve Threshold... 1.1 x Pickup setting
- Reset Curve Threshold 0.9 x Pickup setting
- Time Multiplier..... 0.05 to 1.00
- Protection Enable/Disable Trip1, 2, 3
- Measurement Method DFT – derived 3I₀
- Set-Point Groups..... Group 1 and Group 2

Note: For IEEE curves, a multiplier of 1 corresponds to a IAC/CO “time-dial” setting of 15.

Note: CT saturation is not detected. Enable overcurrent protection when fault levels can exceed 15 times the phase-CT-primary rating.

5.6 Definite-Time 3I₀ Earth Fault

Menu: *Setup | Protection | 3I₀ Def Time*

This protection is based on the zero-sequence current calculated from the phase currents.

- Trip Level..... 0.10 to 15.00 x CT-Primary Rating (I_p)
- Trip Delay (D)..... 0.00 to 10.00 s (see Table 5.2)
- Alarm Level 0.10 to 15.00 x I_p
- Alarm Delay (D)..... 0.00 to 10.00 s (see Table 5.2)
- Protection Enable/Disable Trip1, 2, 3
Enable/Disable Alarm1, 2, 3
- Measurement Method DFT—derived 3I₀
- Set-Point Groups..... Group 1 and Group 2

Note: For IEEE curves, a multiplier of 1 corresponds to a IAC/CO “time-dial” setting of 15.

Note: CT saturation is not detected. Enable overcurrent protection when fault levels can exceed 15 times the phase-CT-primary rating.

5.7 Definite-Time Earth Fault

Menu: *Setup | Protection | Ict Def Time*

This protection function uses the earth-fault-CT input. The protection setting range is equal to the earth-fault-CT-primary rating (I_e).

Trip Level.....	0.01 to 1.00 x Earth-Fault CT primary rating (I_e)
Trip Delay (D).....	0.00 to 100.00 s (see Table 5.2)
Alarm Level.....	0.01 to 1.00 x I_e
Alarm Delay (D).....	0.00 to 100.00 s (see Table 5.2)
Protection	Enable/Disable Trip1, 2, 3 Enable/Disable Alarm1, 2, 3
Measurement Method	DFT c/w saturation compensation
Set-Point Groups.....	Group 1 and Group 2

5.8 Current Unbalance

Menu: *Setup | Protection | Unbalance*

Menu: *Setup | System Config | I_2/I_1 Threshold*

Positive-sequence current (I_1) and negative-sequence current (I_2) are used to determine current unbalance (I_2/I_1). The unbalance display range is 0.00 to 1.00 where 1.00 is 100% unbalance—a single-phase condition. Single-phase loads generate unbalance that may cause false trips when feeder currents are low. The I_2/I_1 Threshold sets the current level where unbalance protection becomes active. The threshold is based on the maximum of the three-phase currents. Set this value above the single-phase load value to avoid false trips. Negative unbalance is indicated when current inputs are connected B-A-C (negative-sequence current is greater than positive-sequence current). Severe unbalance may also be indicated if phase-CT polarity is incorrect.

Trip Level.....	0.05 to 1.00
Trip Delay	1.00 to 100.00 s
Alarm Level.....	0.05 to 1.00
Alarm Delay	1.00 to 100.00 s
Protection	Enable/Disable Trip1, 2, 3 Enable/Disable Alarm1, 2, 3
Threshold.....	0.10 to 0.50 x I_p
Measurement Method	DFT

5.9 Phase Loss

Menu: *Setup | Protection | Phase Loss*

Phase loss is a severe form of unbalance and can be used to detect open-circuit faults. When phase loss occurs on a 3-phase load, negative-sequence current (I_2) is equal to positive-sequence current (I_1). The phase-loss algorithm considers I_2/I_1 from 0.90 to 1.00 to be a phase loss. Set the phase-loss trip delay shorter than the unbalance trip delay to avoid an unbalance trip in the event of a phase loss.

The phase-loss threshold is fixed at 10% of the CT-primary rating (I_p).

Trip Delay.....	1.00 to 100.00 s
Alarm Delay.....	1.00 to 100.00 s
Protection	Enable/Disable Trip1, 2, 3 Enable/Disable Alarm1, 2, 3
Measurement Method	DFT

5.10 Phase Reverse

Menu: *Setup | Protection | Phase Rev*

If the current phase sequence is B-A-C, the magnitude of negative-sequence current will be larger than the magnitude of positive-sequence current. To maintain magnitude consistency for set points, the I_2/I_1 ratio is inverted for the protection algorithm when phase sequence is B-A-C. A negative unbalance is indicated in the meter display for B-A-C sequence.

The phase-reverse threshold is fixed at 10% of the CT-primary rating (I_p).

Trip Delay.....	1.00 to 100.00 s
Alarm Delay.....	1.00 to 100.00 s
Protection	Enable/Disable Trip1, 2, 3 Enable/Disable Alarm 1, 2, 3
Measurement Method	DFT

5.11 PTC Temperature

Menu: *Setup | Hardware | Temp Sensor Type*

Menu: *Setup | Protection | PTC Local Temp*

The local-temperature-sensor input is configured for a positive-temperature-coefficient (PTC) thermistor sensor using the *Setup | Hardware | Temp Sensor Type* menu.

The total resistance of series-connected PTC thermistors must be less than 1,500 Ω at 20°C. A trip or alarm will occur when series resistance exceeds 2,800 Ω .

During Emergency Thermal Reset, a PTC trip is reset and PTC-temperature protection is disabled. See Section 5.2.2.

Protection	Enable/Disable Trip1, 2, 3 Enable/Disable Alarm1, 2, 3
------------------	---



5.12 RTD Temperature

Menu: *Setup | Hardware | Temp Sensor Type*

Menu: *Setup | Protection | RTD Temperature*

The local-temperature-sensor input is configured for a Pt100 RTD sensor using the *Setup | Hardware | Temp Sensor Type* menu.

Sensor verification is enabled using the *Sensor Trip Act* and *Sensor Alarm Act* Action menus. When a sensor failure is detected, the corresponding protection is disabled.

During Emergency Thermal Reset, an RTD trip is reset and RTD-temperature protection is disabled. See Section 5.2.2.

- Trip Range40.00 to 230.00°C
- Alarm Range40.00 to 230.00°C
- Display Range-40 to 260°C
- Sensor VerificationEnable/Disable Trip 1, 2, 3
Enable/Disable Alarm 1, 2, 3
- ProtectionEnable/Disable Trip 1, 2, 3
Enable/Disable Alarm 1, 2, 3

This page intentionally left blank.

6. THEORY OF OPERATION

6.1 Signal-Processing Algorithm

The PGR-7200 obtains thirty-two samples per cycle of each current signal — the sampling frequency is 1.6 kHz in 50-Hz applications and 1.92 kHz in 60-Hz applications.

A Discrete-Fourier-Transform (DFT) algorithm is used to obtain the magnitudes and phase angles of the fundamental-frequency components of the current waveforms. These values provide true positive-, negative-, and zero-sequence components. True RMS values of phase currents include up to the 16th harmonic. Fundamental-frequency values are displayed.

Peak-to-peak currents are measured and compared to DFT values to compensate for CT saturation.

This page intentionally left blank

7. COMMUNICATIONS

7.1 Personal-Computer Interface

7.1.1 Firmware Upgrade

The PGR-7200 control program is stored in flash memory. Field updates can be made through the TIA-232 communication interface located on the rear panel. The following are required:

- A Windows® PC, a TIA-232 interface, and the PGW-FLSH program,
- a file containing the PGR-7200 control program (.s19 file), and
- an RJ-45 to DB9 adapter (PGA-0420).

PGW-FLSH is available at www.littelfuse.com and a PGA-0420 adapter is available from Littelfuse, Inc.

7.1.2 PGW-COMM

PGW-COMM Relay Interface Software is a Windows®-based program used to access PGR-7200 functions with a personal computer (PC) via the TIA-232 or optional TIA-485 and Ethernet interfaces. Use PGW-COMM to program a PGR-7200 either by changing individual set points or by downloading set-point files. Existing PGR-7200 set points can be transferred to the PC. Metered values can be viewed and the PGR-7200 can be controlled with the computer. PGW-COMM extends the event-record storage capability of the PGR-7200 by allowing the user to transfer data to PC memory at a programmable interval. Protection curve plotting capability is included. PGW-COMM is available at www.littelfuse.com.

7.2 Network Interface

For detailed information see Appendices to this manual and applicable communications manuals.

7.2.1 TIA-485 Option

The TIA-485 communications option supports Modbus® RTU and Allen-Bradley® DF1 half-duplex protocols. All set points and meter values are accessible. Commands are provided to perform trips, resets, and remote relay control.

Modbus® RTU function codes supported:

- Read Holding Registers (Code 3)
- Read Input Registers (Code 4)
- Write Single Register (Code 6)
- Write Multiple Registers (Code 16)
- Command Instruction (Code 5)

DF1 commands supported:

- Unprotected Read (CMD = 01)
- Unprotected Write (CMD = 08)
- Typed Read (CMD = 0F, FNC = 68)
- Typed Write (CMD = 0F, FNC = 67)
- Typed Logical Read (CMD = 0F, FNC = A2)
- Typed Logical Write (CMD = 0F, FNC = AA)

7.2.2 DeviceNet Option

The DeviceNet™ communications option supports Explicit Messaging and Polled I/O. All set points and meter values are accessible using Explicit Messaging. The Polled I/O connection supports the following ODVA input assemblies:

- Basic Overload (50)
- Extended Overload (51)
- Basic Motor Starter (52)
- Extended Motor Starter (53)

In addition to the ODVA assemblies, a user-configurable fixed block of 64 bytes is available.

The Polled I/O connection supports the following ODVA output assemblies:

- Basic Overload (2)
- Basic Motor Starter (3)

An Electronic Data Sheet (EDS) file is provided for use with DeviceNet configuration tools such as RSNetWorx and DeltaV.

7.2.3 Ethernet Option

The Ethernet option supports the Modbus® TCP protocol. Modbus® TCP uses TCP/IP to encapsulate the Modbus® RTU protocol. Up to five simultaneous connections are supported. In addition to the Modbus® RTU function codes listed in Section 7.2.1, the Read Device Identification Code (43) is supported.

The PGR-7200 Modbus® TCP interface is compatible with PGW-COMM Version 1.6 and above. See Section 7.1.2.

This page intentionally left blank

8. TECHNICAL SPECIFICATIONS

8.1 PGR-7200

Supply..... 30 VA, 65 to 265 Vac,
 40 to 400 Hz.
 25 W, 80 to 275 Vdc.

Power-Up Time 800 ms at 120 Vac

Ride-Through Time 100 ms minimum

24-Vdc Source ⁽¹⁾ 400 mA maximum

AC Measurements:

Methods..... True RMS, DFT, Peak,
 and positive- and
 negative-sequence
 components of the
 fundamental.

Sample Rate 32 samples/cycle.

Frequency:..... 50 or 60 Hz

Phase-Current Measurement: ⁽²⁾

Metering Range..... 15 x CT-Primary Rating (I_p)

Protection Range..... 80 x I_p

Metering Accuracy: ^(3,4)

$I < I_p$ 2% I_p

$I > I_p$ 2% Reading

Unbalance Accuracy 0.02 pu

Earth-Leakage Measurement:

Range..... 1.5 x Earth-Fault-CT-
 Primary Rating (I_e)

Accuracy ^(3,4) 2% I_e

PTC-Thermistor Input: ⁽⁷⁾

Cold Resistance 1,500 Ω maximum at 20°C

Trip Level..... 2,800 $\Omega \pm 200 \Omega$

Reset Level 1,500 $\Omega \pm 200 \Omega$

Sensor Current..... 1 mA maximum

RTD Input: ⁽⁷⁾

RTD Type 3 wire Pt100

Range..... -40 to 260°C with open
 and short detection

Sensor Current..... 1 mA

Lead Compensation 25 Ω maximum

Accuracy..... 2°C (-40 to 200°C)

5°C (200 to 260°C)

4–20-mA Analog Output:

Type..... Self powered and loop
 powered

Range 4 to 22 mA

Update Time 250 ms

Loop Voltage..... 8 to 26 Vdc

Load..... 500 Ω (maximum with
 24 Vdc supply)

Isolation ⁽¹⁾ 120 Vac with L/S switch
 in L position

Timing Accuracies: ⁽⁵⁾

I^2t Overload 2%, 100 ms resolution

IEC/IEEE Curves 5%, 10 ms resolution

Definite Time..... 2%, 10 ms resolution

Phase Unbalance,
 Loss, Reverse..... 2%, 100 ms resolution

Relay Contacts:

Configuration N.O. and N.C. (Form C)

UL/CSA Contact Rating... 8 A resistive 250 Vac,
 8 A resistive 30 Vdc

Supplemental Contact Ratings:

Make/Carry 0.2 s 20 A

Break:

dc..... 50 W resistive,
 25 W inductive (L/R = 0.04)

ac..... 2,000 VA resistive,
 1,500 VA inductive
 (PF = 0.4)

Subject to maximums of 8 A and 250 V (ac
 or dc).

Digital Input: ⁽¹⁾

Range 12 to 36 Vdc, 5 mA at
 24 Vdc

Guaranteed On..... 12 Vdc at 2 mA

Guaranteed Off..... 3 Vdc at 0.5 mA

Isolation 120 Vac

I/O Module Interface:

Module Supply ⁽¹⁾ 24 Vdc, 400 mA maximum

Configuration TIA-485, 2 wire multi-drop

Bus Length..... 1.2 km (4,000') maximum

Cable Belden 3124A or
 equivalent

TIA-232 Communications:

Baud Rate..... 9.6, 19.2, 38.4 kbits

Protocol..... Modbus RTU

Address..... 1 to 255

Real-Time Clock:

Power-Off Operation..... 6 Months at 20°C

Battery Rechargeable lithium
 (no service required)

Non-Volatile RAM:
Power-Off Retention..... 10 Years

Shipping Weight2.0 kg (4.4 lb)

PWB Conformal CoatingMIL-1-46058 qualified
UL QMJU2 recognized

Environment:
Operating Temperature...-40 to 60°C ⁽⁶⁾
Storage Temperature-55 to 80°C
Humidity85% Non-Condensing

Surge Withstand.....ANSI/IEEE C37.90.1-1989
(Oscillatory and Fast
Transient)

Inverse Time CurvesIEEE Std C37.112-1996
CEI/IEC 255-3:1989

Certification.....CSA, USA and Canada



To:
UL 508 Industrial Control Equipment
UL 1053 Ground Fault Sensing and Relaying
Equipment
CSA C22.2 No. 14 Industrial Control Equipment

Notes:

- (1) The I/O module supply and analog output are referenced to the same supply when the L/S switch is in the "S" position. In the "L" position, the analog output's isolation is 120 Vac.
- (2) Current threshold is 2% of phase-CT rating. To maintain specified accuracy, phase CT's should be selected with a primary rating between 100 and 300% of rated current.
- (3) Transformer accuracy not included.
- (4) Accuracy is a function of PGA-0CIM to PGR-7200 cable resistance: % Accuracy = $2 + 0.65 \times \text{cable resistance } (\Omega)$.
- (5) Minimum time is 25 to 45 ms. See Table 5.2 for fault duration required.
- (6) Display readability decreases at temperatures below -20°C.
- (7) PTC and RTD sensors are mutually exclusive.

8.2 Current Input Module (PGA-0CIM)

CT Inputs:
Thermal Withstand:
Continuous5 x CT-Secondary Rating
1-Second.....80 x CT-Secondary Rating

Burden:
1- and 5-A inputs< 0.01 Ω
PGC-3xxx input.....10 Ω

Interconnection Cable:
Type..... Littelfuse P75-P300-20030
Resistance 5.3 Ω /100 m (328') ⁽⁴⁾
Supplied Length..... 6 m (19')

Terminal-Block Ratings:
CT Inputs.....25 A, 500 Vac,
10 AWG (4.0 mm²)

Shipping Weight..... 0.4 kg (0.9 lb)

PWB Conformal Coating.... MIL-1-46058 qualified
UL QMJU2 recognized

Environment:
Operating Temperature -40 to 60°C
Storage Temperature ... -55 to 80°C
Humidity..... 85% Non-Condensing

Surge Withstand ANSI/IEEE C37.90.1-1989
(Oscillatory and Fast
Transient)

Certification CSA, USA and Canada

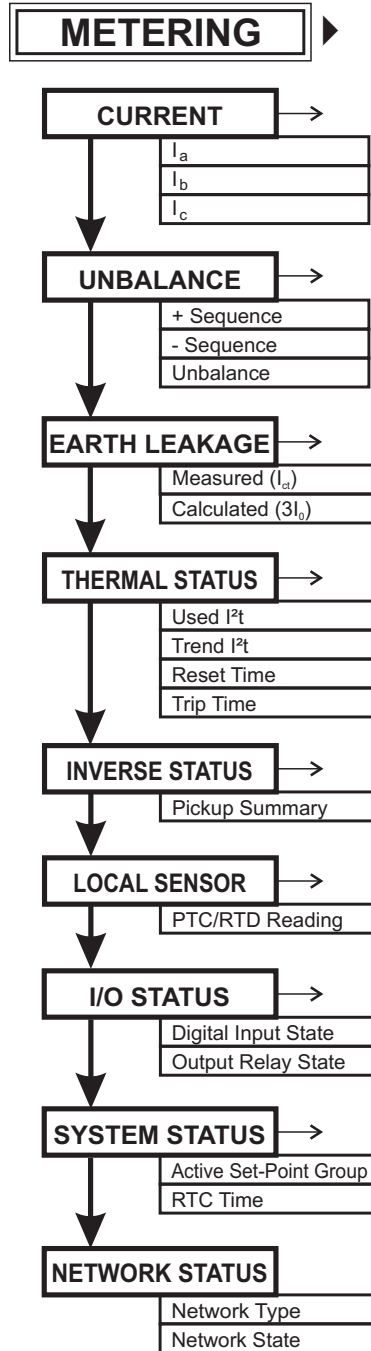

To:
UL 508 Industrial Control Equipment
UL 1053 Ground Fault Sensing and Relaying
Equipment
CSA C22.2 No. 14 Industrial Control Equipment

APPENDIX A
PGR-7200 MENU MAP
MAIN MENU

Notes:

- (1) List indicates possible trips and alarms.
- (2) Password required.
- (3) Lists do not match PGR-7200 menu order.
- (4) Locked when current detected.

Legend:

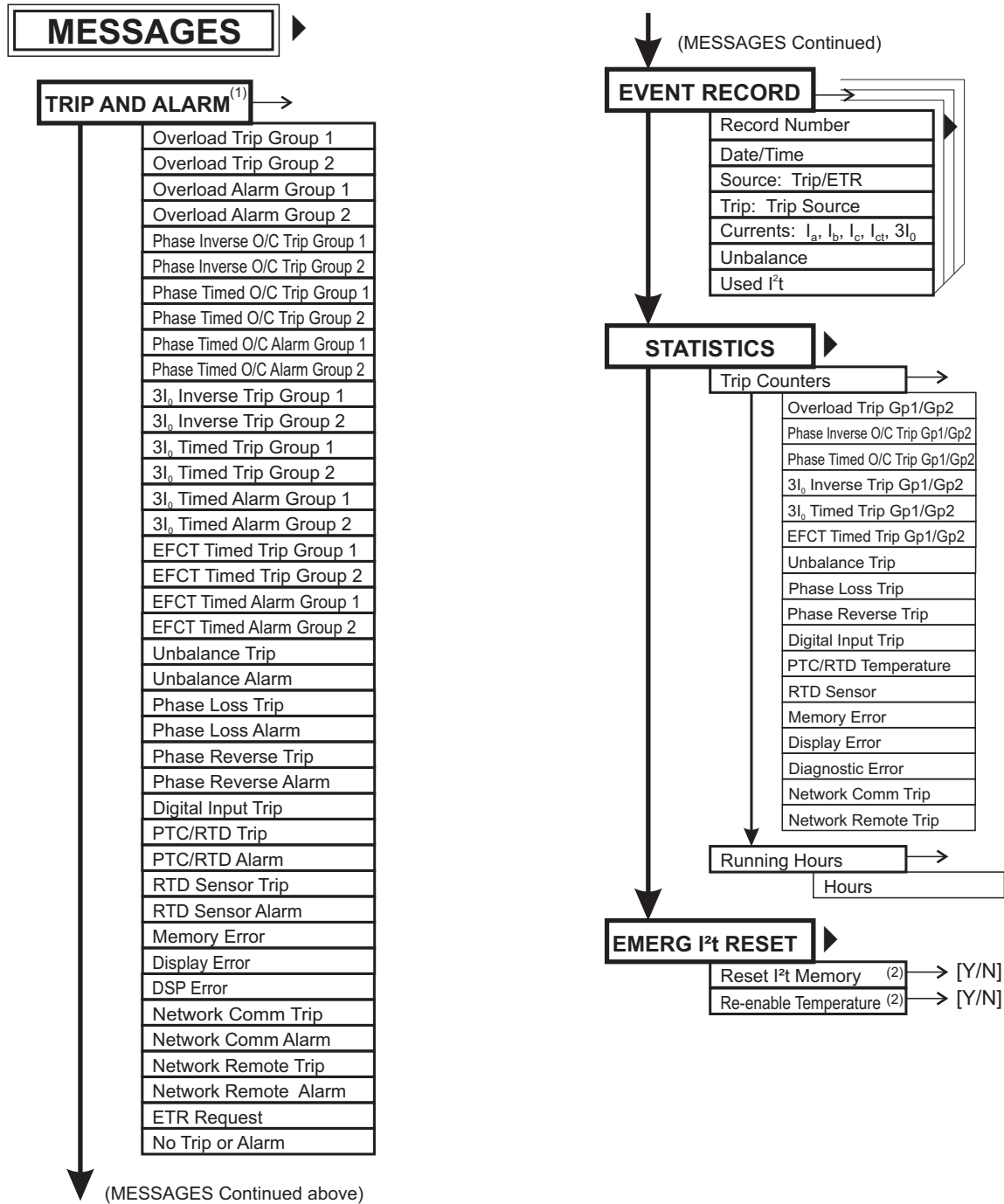
[x]	Enter numeric
[s]	Enter string
[E/D]	Enable/Disable
[TA]	Trip Action: Disable; Trip1; Trip2; Trip3
[AA]	Alarm Action: Disable; Alarm1; Alarm2; Alarm3
[Y/N]	Yes/No
[EA]	Ethernet address

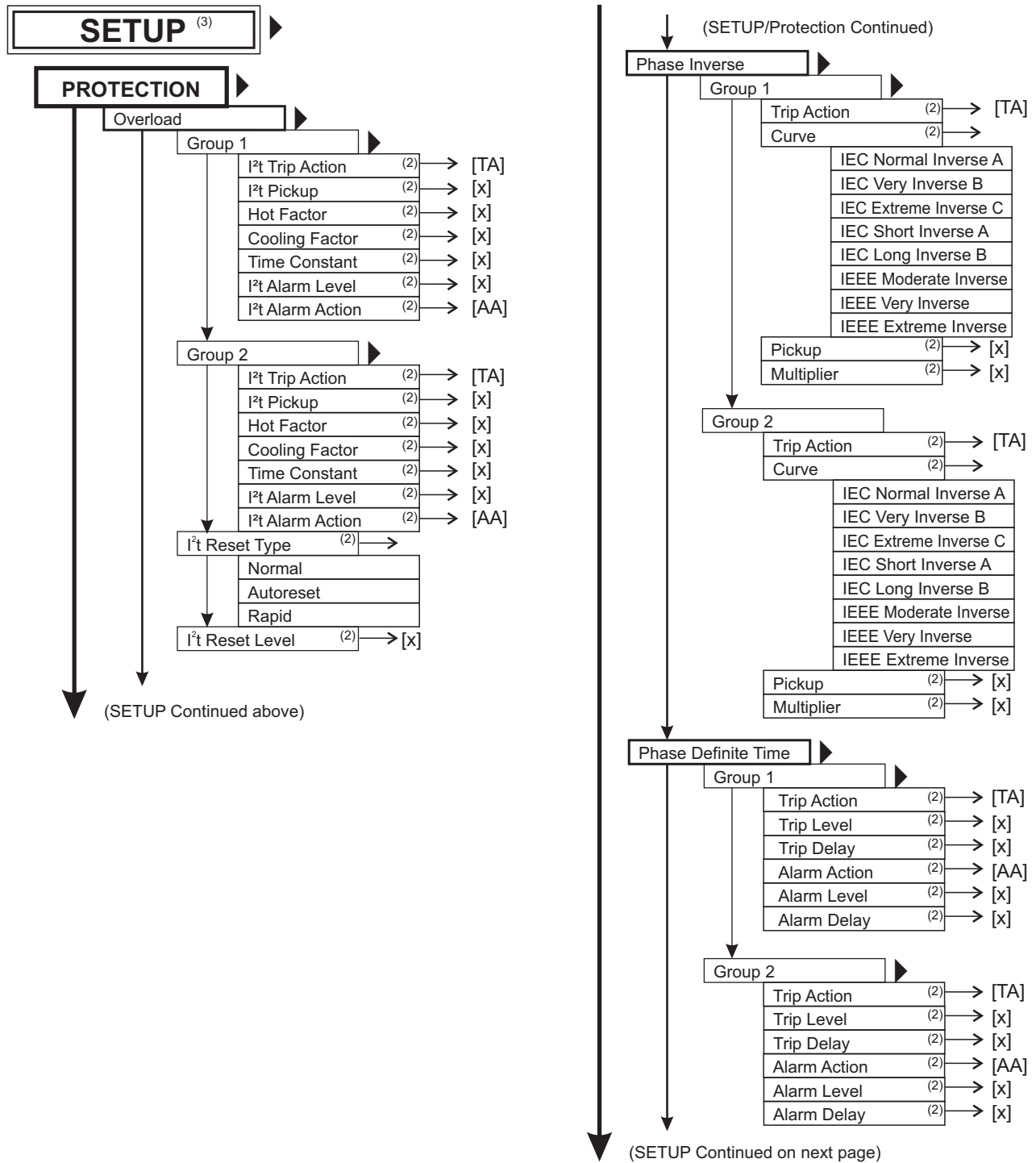



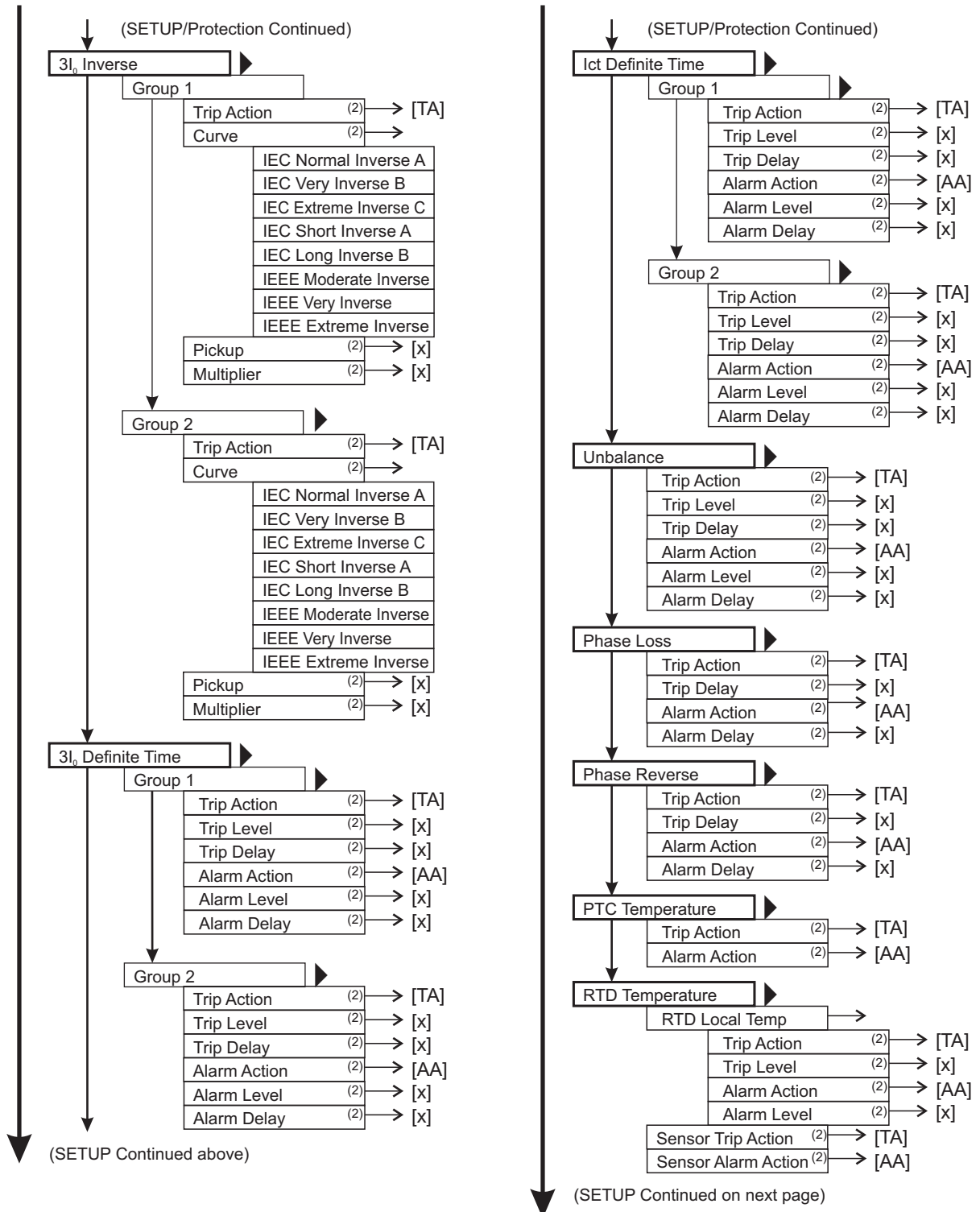

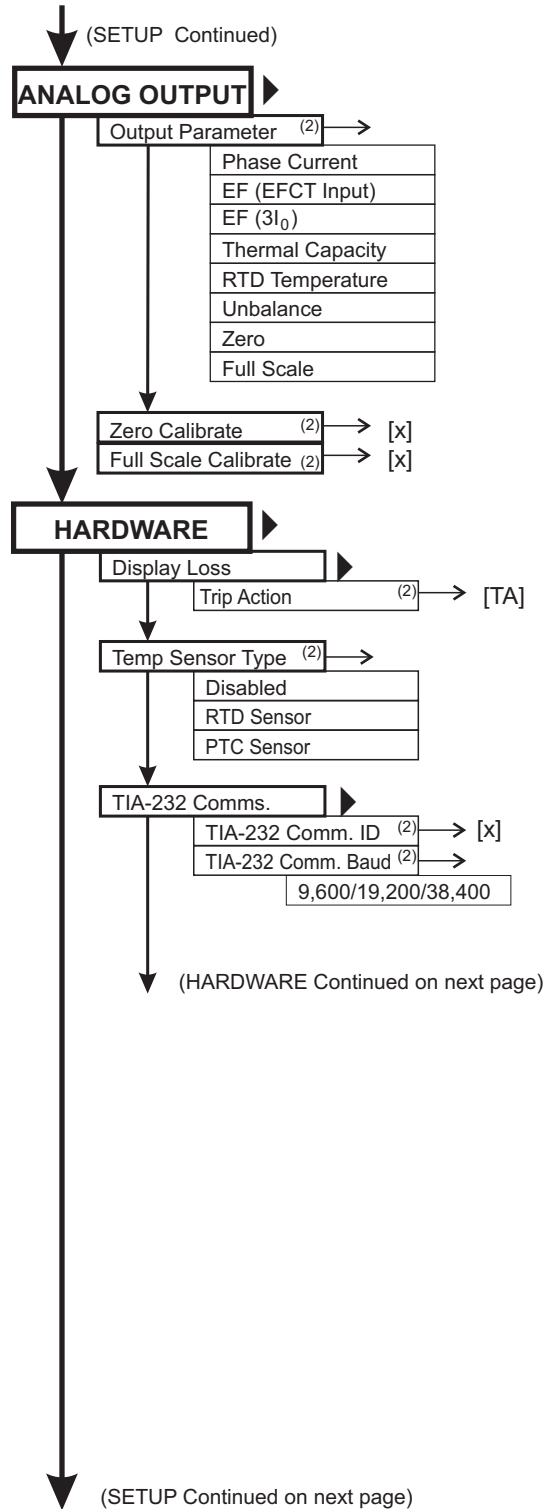
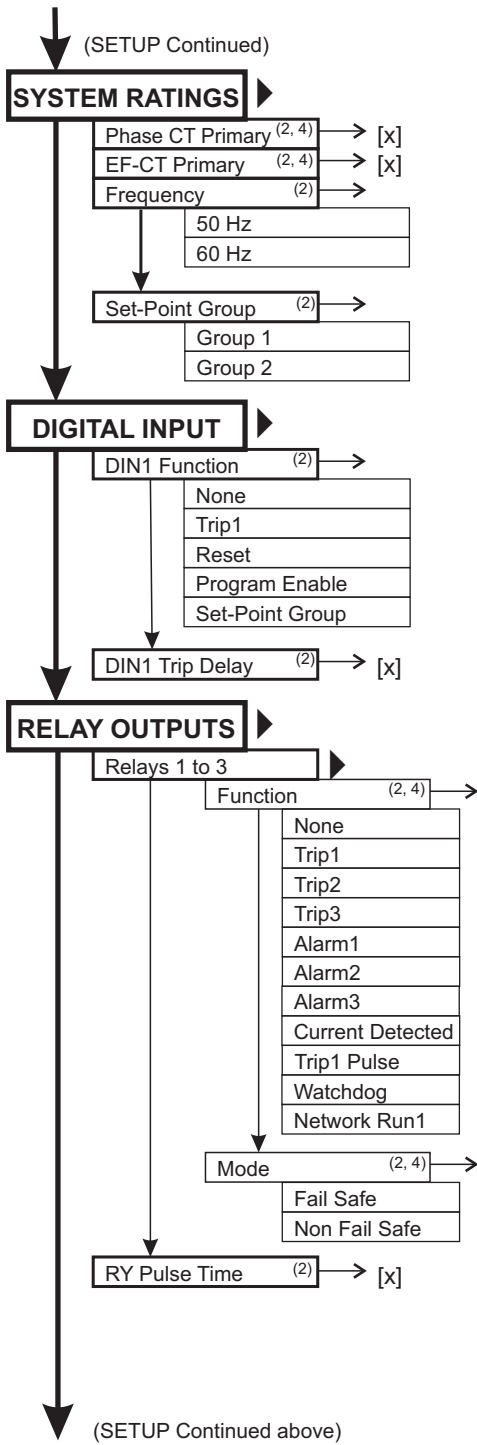

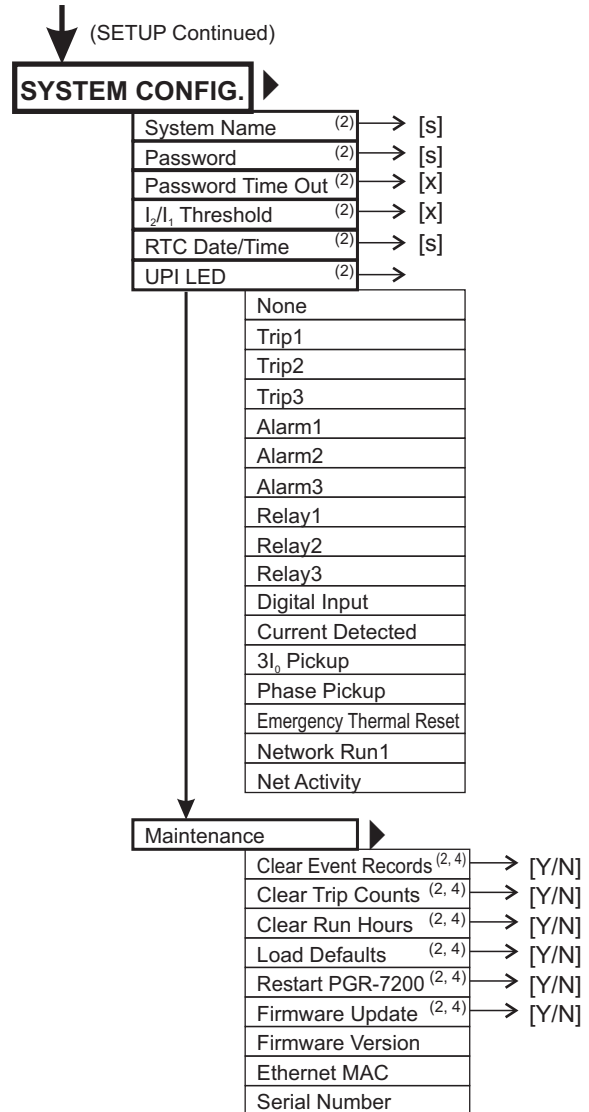
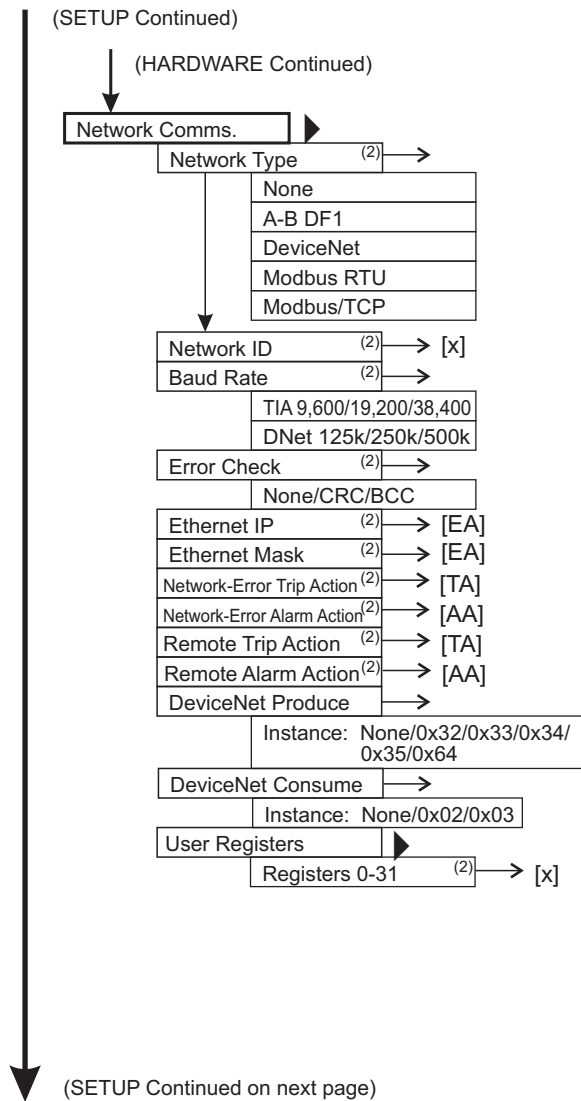



**APPENDIX B
PGR-7200 SET-UP RECORD**

Feeder: _____ PGR-7200 S/N: _____ Date: _____

Firmware Revision: _____ Ethernet MAC ID: _____

PART I: SYSTEM PARAMETERS

PARAMETER AND SETTINGS	MIN	DEFAULT	MAX	UNIT	PROGRAM SELECTION
System Ratings					
CT Primary (I_p) ⁽¹⁾	1	100.00	5,000	A	
EF-CT Primary (I_e) ⁽¹⁾	1	5.00	5,000	A	
Set-Point Group		Group1			<input type="checkbox"/> Group1 <input type="checkbox"/> Group2
Frequency		60		Hz	<input type="checkbox"/> 50 <input type="checkbox"/> 60
Digital Input					
Function		None			<input type="checkbox"/> None <input type="checkbox"/> Program Enable <input type="checkbox"/> Trip1 <input type="checkbox"/> Set-Point Group <input type="checkbox"/> Reset
Trip Delay	0.01	0.10	100.00	s	
Relay Outputs See Table 4.2 Output-Relay Functions					
Relay 1: Function		Trip1			
Mode		Fail Safe			<input type="checkbox"/> Fail Safe <input type="checkbox"/> Non-Fail Safe
Relay 2: Function		Alarm1			
Mode		Fail Safe			<input type="checkbox"/> Fail Safe <input type="checkbox"/> Non-Fail Safe
Relay 3: Function		None			
Mode		Fail Safe			<input type="checkbox"/> Fail Safe <input type="checkbox"/> Non-Fail Safe
RY Pulse Time	0.05	0.25	10.00	s	
Analog Output See Table 4.4 Analog-Output Parameters					
Output Parameter		Phase Current			
Zero Calibrate		Factory Calibrated			
Full-Scale Calibrate		Factory Calibrated			
HARDWARE					
OPI Display					
OPI-Loss Trip		Trip1			<input type="checkbox"/> Disabled <input type="checkbox"/> Trip1 <input type="checkbox"/> Trip2 <input type="checkbox"/> Trip3
TIA-232 Communications					
TIA-232 Comm ID	0	254	255		
TIA-232 Comm Baud		9,600		bit/s	<input type="checkbox"/> 9,600 <input type="checkbox"/> 38,400 <input type="checkbox"/> 19,200
Temperature Sensor Type		Disabled			<input type="checkbox"/> Disabled <input type="checkbox"/> PTC Sensor <input type="checkbox"/> RTD Sensor

PARAMETER AND SETTINGS	MIN	DEFAULT	MAX	UNIT	PROGRAM SELECTION
Network Communications					
Network Type		None			<input type="checkbox"/> None <input type="checkbox"/> Modbus TCP <input type="checkbox"/> A-B DF1 <input type="checkbox"/> DeviceNet <input type="checkbox"/> Modbus RTU
Network ID	0	254	255		
Baud Rate		TIA 9600			<input type="checkbox"/> TIA 9600 <input type="checkbox"/> DN125 <input type="checkbox"/> TIA 19k2 <input type="checkbox"/> DN250 <input type="checkbox"/> TIA 38k4 <input type="checkbox"/> DN500
Error Checking (A-B DF1 Only)		Not Selected			<input type="checkbox"/> Not Selected <input type="checkbox"/> BCC <input type="checkbox"/> CRC
Ethernet IP		192.168. 000.001			
Ethernet Mask		255.255. 255.000			
Network-Error Trip Action		Disabled			<input type="checkbox"/> Disabled <input type="checkbox"/> Trip1 <input type="checkbox"/> Trip2 <input type="checkbox"/> Trip3
Network-Error Alarm Action		Disabled			<input type="checkbox"/> Disabled <input type="checkbox"/> Alarm1 <input type="checkbox"/> Alarm2 <input type="checkbox"/> Alarm3
Remote Trip Action		Disabled			<input type="checkbox"/> Disabled <input type="checkbox"/> Trip1 <input type="checkbox"/> Trip2 <input type="checkbox"/> Trip3
Remote Alarm Action		Disabled			<input type="checkbox"/> Disabled <input type="checkbox"/> Alarm1 <input type="checkbox"/> Alarm2 <input type="checkbox"/> Alarm3
User Registers					
User Register 0	0	0	1399		
User Register 1	0	0	1399		
User Register 2	0	0	1399		
User Register 3	0	0	1399		
User Register 4	0	0	1399		
User Register 5	0	0	1399		
User Register 6	0	0	1399		
User Register 7	0	0	1399		
User Register 8	0	0	1399		
User Register 9	0	0	1399		
User Register 10	0	0	1399		
User Register 11	0	0	1399		
User Register 12	0	0	1399		
User Register 13	0	0	1399		
User Register 14	0	0	1399		
User Register 15	0	0	1399		
User Register 16	0	0	1399		
User Register 17	0	0	1399		
User Register 18	0	0	1399		
User Register 19	0	0	1399		
User Register 20	0	0	1399		
User Register 21	0	0	1399		
User Register 22	0	0	1399		
User Register 23	0	0	1399		
User Register 24	0	0	1399		

PARAMETER AND SETTINGS	MIN	DEFAULT	MAX	UNIT	PROGRAM SELECTION
User Register 25	0	0	1399		
User Register 26	0	0	1399		
User Register 27	0	0	1399		
User Register 28	0	0	1399		
User Register 29	0	0	1399		
User Register 30	0	0	1399		
User Register 31	0	0	1399		
SYSTEM CONFIG					
System Name	POWR-GARD PGR-7200				
Password		1111			
Password Timeout	1	10.00	60	min	
I_2/I_1 Threshold	0.05	0.50	0.50	$x I_p$	
UPI LED		None	See Table 4.1 UPI LED Functions		

PART II: PROTECTION SET POINTS

FUNCTION & SET POINT	MIN	DEFAULT	MAX	UNIT	PROGRAM SELECTION
Overload – Group1					
I^2t Trip Action		Trip1			<input type="checkbox"/> Disabled <input type="checkbox"/> Trip1 <input type="checkbox"/> Trip2 <input type="checkbox"/> Trip3
I^2t Alarm Action		Alarm1			<input type="checkbox"/> Disabled <input type="checkbox"/> Alarm1 <input type="checkbox"/> Alarm2 <input type="checkbox"/> Alarm3
I^2t Pickup	0.10	1.00	1.25	$x I_p$	
Hot Factor	0.10	0.50	1.00		
Cooling Factor	0.10	1.00	10.00		
Time Constant	1.00	10.0	60.00	min	
I^2t Alarm level (Per unit based on 100% I^2t)	0.50	0.90	1.00	pu	
Overload – Group2					
I^2t Trip Action		Trip1			<input type="checkbox"/> Disabled <input type="checkbox"/> Trip1 <input type="checkbox"/> Trip2 <input type="checkbox"/> Trip3
I^2t Alarm Action		Alarm1			<input type="checkbox"/> Disabled <input type="checkbox"/> Alarm1 <input type="checkbox"/> Alarm2 <input type="checkbox"/> Alarm3
I^2t Pickup	0.10	1.00	1.25	$x I_p$	
Hot Factor	0.10	0.50	1.00		
Cooling Factor	0.10	1.00	10.00		
Time Constant	1.00	10.0	60.00	min	
I^2t Alarm level (Per unit based on 100% I^2t)	0.50	0.90	1.00	pu	
Overload Reset Type		Normal			<input type="checkbox"/> Normal <input type="checkbox"/> Rapid <input type="checkbox"/> Auto
Overload Reset Level	0.10	0.30	0.90	pu	

FUNCTION & SET POINT	MIN	DEFAULT	MAX	UNIT	PROGRAM SELECTION
Phase Inverse – Group1					
Trip Action		Trip1			<input type="checkbox"/> Disabled <input type="checkbox"/> Trip1 <input type="checkbox"/> Trip2 <input type="checkbox"/> Trip3
Curve Type		IEC Normal			See Table 5.1
Curve Pickup	0.10	2.00	10.00	x I _p	
Curve Multiplier	0.05	0.20	1.00		
Phase Inverse – Group2					
Trip Action		Trip1			<input type="checkbox"/> Disabled <input type="checkbox"/> Trip1 <input type="checkbox"/> Trip2 <input type="checkbox"/> Trip3
Curve Type		IEC Normal			See Table 5.1
Curve Pickup	0.10	2.00	10.0	x I _p	
Curve Multiplier	0.05	0.20	1.00		
Phase Definite Time – Group1					
Trip Action		Disabled			<input type="checkbox"/> Disabled <input type="checkbox"/> Trip1 <input type="checkbox"/> Trip2 <input type="checkbox"/> Trip3
Trip Level	0.10	10.00	15.00	x I _p	
Trip Delay	0.00	0.05	10.00	s	
Alarm Action		Disabled			<input type="checkbox"/> Disabled <input type="checkbox"/> Alarm1 <input type="checkbox"/> Alarm2 <input type="checkbox"/> Alarm3
Alarm Level	0.10	10.00	15.00	x I _p	
Alarm Delay	0.00	0.05	10.00	s	
Phase Definite Time – Group2					
Trip Action		Disabled			<input type="checkbox"/> Disabled <input type="checkbox"/> Trip1 <input type="checkbox"/> Trip2 <input type="checkbox"/> Trip3
Trip Level	0.10	10.00	15.00	x I _p	
Trip Delay	0.00	0.05	10.00	s	
Alarm Action		Disabled			<input type="checkbox"/> Disabled <input type="checkbox"/> Alarm1 <input type="checkbox"/> Alarm2 <input type="checkbox"/> Alarm3
Alarm Level	0.10	10.00	15.00	x I _p	
Alarm Delay	0.00	0.05	10.00	s	
Earth-Fault 3I₀ Inverse – Group1					
Trip Action		Trip1			<input type="checkbox"/> Disabled <input type="checkbox"/> Trip1 <input type="checkbox"/> Trip2 <input type="checkbox"/> Trip3
Curve Type		IEC Normal			See Table 5.1
Curve Pickup	0.10	2.00	10.00	x I _p	
Curve Multiplier	0.05	0.20	1.00		
Earth-Fault 3I₀ Inverse – Group2					
Trip Action		Trip1			<input type="checkbox"/> Disabled <input type="checkbox"/> Trip1 <input type="checkbox"/> Trip2 <input type="checkbox"/> Trip3
Curve Type		IEC Normal			See Table 5.1
Curve Pickup	0.10	2.00	10.00	x I _p	
Curve Multiplier	0.05	0.20	1.00		

FUNCTION & SET POINT	MIN	DEFAULT	MAX	UNIT	PROGRAM SELECTION
Earth-Fault $3I_0$ Definite Time – Group1					
Trip Action		Disabled			<input type="checkbox"/> Disabled <input type="checkbox"/> Trip1 <input type="checkbox"/> Trip2 <input type="checkbox"/> Trip3
Trip Level	0.10	10.00	15.00	$x I_p$	
Trip Delay	0.00	0.05	10.00	s	
Alarm Action		Disabled			<input type="checkbox"/> Disabled <input type="checkbox"/> Alarm1 <input type="checkbox"/> Alarm2 <input type="checkbox"/> Alarm3
Alarm Level	0.10	10.00	15.00	$x I_p$	
Alarm Delay	0.00	0.05	10.00	s	
Earth-Fault $3I_0$ Definite Time – Group2					
Trip Action		Disabled			<input type="checkbox"/> Disabled <input type="checkbox"/> Trip1 <input type="checkbox"/> Trip2 <input type="checkbox"/> Trip3
Trip Level	0.10	10.00	15.00	$x I_p$	
Trip Delay	0.00	0.05	10.00	s	
Alarm Action		Disabled			<input type="checkbox"/> Disabled <input type="checkbox"/> Alarm1 <input type="checkbox"/> Alarm2 <input type="checkbox"/> Alarm3
Alarm Level	0.10	10.00	15.00	$x I_p$	
Alarm Delay	0.00	0.05	10.00	s	
Earth-Fault CT Input Definite Time – Group1					
Trip Action		Trip1			<input type="checkbox"/> Disabled <input type="checkbox"/> Trip1 <input type="checkbox"/> Trip2 <input type="checkbox"/> Trip3
Trip Level	0.01	0.40	1.00	$x I_e$	
Trip Delay	0.00	0.25	100.00	s	
Alarm Action		Alarm1			<input type="checkbox"/> Disabled <input type="checkbox"/> Alarm1 <input type="checkbox"/> Alarm2 <input type="checkbox"/> Alarm3
Alarm Level	0.01	0.20	1.00	$x I_e$	
Alarm Delay	0.00	1.00	100.00	s	
Earth-Fault CT Input Definite Time – Group2					
Trip Action		Trip1			<input type="checkbox"/> Disabled <input type="checkbox"/> Trip1 <input type="checkbox"/> Trip2 <input type="checkbox"/> Trip3
Trip Level	0.01	0.40	1.00	$x I_e$	
Trip Delay	0.00	0.25	100.00	s	
Alarm Action		Alarm1			<input type="checkbox"/> Disabled <input type="checkbox"/> Alarm1 <input type="checkbox"/> Alarm2 <input type="checkbox"/> Alarm3
Alarm Level	0.01	0.20	1.00	$x I_e$	
Alarm Delay	0.00	1.00	100.00	s	
Unbalance					
Trip Action		Trip1			<input type="checkbox"/> Disabled <input type="checkbox"/> Trip1 <input type="checkbox"/> Trip2 <input type="checkbox"/> Trip3
Trip Level (Per unit based on I_2/I_1)	0.05	0.25	1.00	pu	
Trip Delay	1.00	15.00	100.00	s	
Alarm Action		Alarm1			<input type="checkbox"/> Disabled <input type="checkbox"/> Alarm1 <input type="checkbox"/> Alarm2 <input type="checkbox"/> Alarm3
Alarm Level (Per unit based on I_2/I_1)	0.05	0.10	1.00	pu	
Alarm Delay	1.00	10.00	100.00	s	



FUNCTION & SET POINT	MIN	DEFAULT	MAX	UNIT	PROGRAM SELECTION	
Phase Loss						
Trip Action		Disabled			<input type="checkbox"/> Disabled <input type="checkbox"/> Trip2	<input type="checkbox"/> Trip1 <input type="checkbox"/> Trip3
Trip Delay	1.00	5.00	100.00	s		
Alarm Action		Disabled			<input type="checkbox"/> Disabled <input type="checkbox"/> Alarm2	<input type="checkbox"/> Alarm1 <input type="checkbox"/> Alarm3
Alarm Delay	1.00	2.00	100.00	s		
Phase Reverse						
Trip Action		Disabled			<input type="checkbox"/> Disabled <input type="checkbox"/> Trip2	<input type="checkbox"/> Trip1 <input type="checkbox"/> Trip3
Trip Delay	1.00	5.00	100.00	s		
Alarm Action		Disabled			<input type="checkbox"/> Disabled <input type="checkbox"/> Alarm2	<input type="checkbox"/> Alarm1 <input type="checkbox"/> Alarm3
Alarm Delay	1.00	2.00	100.00	s		
PTC Temperature						
Trip Action		Disabled			<input type="checkbox"/> Disabled <input type="checkbox"/> Trip2	<input type="checkbox"/> Trip1 <input type="checkbox"/> Trip3
Alarm Action		Disabled			<input type="checkbox"/> Disabled <input type="checkbox"/> Alarm2	<input type="checkbox"/> Alarm1 <input type="checkbox"/> Alarm3
RTD Temperature						
Trip Action		Disabled			<input type="checkbox"/> Disabled <input type="checkbox"/> Trip2	<input type="checkbox"/> Trip1 <input type="checkbox"/> Trip3
Trip Level	40.00	200.00	230.00	°C		
Alarm Action		Disabled			<input type="checkbox"/> Disabled <input type="checkbox"/> Alarm2	<input type="checkbox"/> Alarm1 <input type="checkbox"/> Alarm3
Alarm Level	40.00	130.00	230.00	°C		
RTD-Sensor-Error Trip Action		Disabled			<input type="checkbox"/> Disabled <input type="checkbox"/> Trip2	<input type="checkbox"/> Trip1 <input type="checkbox"/> Trip3
RTD-Sensor-Error Alarm Action		Disabled			<input type="checkbox"/> Disabled <input type="checkbox"/> Alarm2	<input type="checkbox"/> Alarm1 <input type="checkbox"/> Alarm3

⁽¹⁾ Locked when current is detected.



APPENDIX C PGR-7200 TIA-232 MODBUS PROTOCOL

C.1 PROTOCOL

The PGR-7200 implements the Modbus® RTU protocol as described in the Gould Modbus Reference Guide, Publication PI-MBUS-300 Rev. B.

Only the master can initiate a message transaction. Messages can be addressed to individual slaves or they can be broadcast messages. Broadcast messages are executed on the slaves but unlike individually addressed messages, the slaves do not generate a reply message.

Modicon Modbus® is a registered trademark of Schneider Electric.

C.1.1 Protocol Setup

Setup options are available in the *Setup | Hardware | Local Comms* menu. Select *Local Comm ID* and *Local Comm Baud*.

C.2 MESSAGE SYNCHRONIZATION

Message synchronization is accomplished by detection of an idle communication line. The communication line is considered idle when no communication exists for an equivalent delay of 3.5 characters.

The first byte received after idle-line detection is interpreted as the address byte of the next message. Message bytes must be transmitted in a continuous stream until the complete message has been sent. If a delay of more than 3.5 characters exists within the message, the message is discarded.

Response messages from the PGR-7200 are delayed by at least 3.5 character delays.

C.3 ERROR CHECKING

Modbus® RTU uses a 16-bit cyclic redundancy check (CRC). The error check includes all of the message bytes, starting with the first address byte.

When a CRC error is detected, the message is discarded and there will be no response.

If the CRC check is correct but the internal data in the message is not correct, the PGR-7200 will respond with an exception response code.

C.4 FUNCTION CODES SUPPORTED

The PGR-7200 Modbus Protocol supports the following function codes:

- Read Holding Registers (Function Code 3)
- Read Input Registers (Function Code 4)
- Write Single Register (Function Code 6)
- Write Multiple Registers (Function Code 16)
- Command Instruction (Function Code 5)

Function Codes 3 and 4 perform the same function in the PGR-7200.

Registers in Modbus start at 40001 decimal and the register address generated for this register is 0.

C.4.1 Application Layer

The hexadecimal system is used. Value representations use the “C” convention. For hexadecimal, 0x precedes the value.

C.4.2 Read Input/Holding Registers (Code 04/03)

The first byte of the read message is the slave address. The second byte is the function code. Bytes three and four indicate the starting register. The next two bytes specify the number of 16-bit registers to read. The last two bytes contain the CRC code for the message.

TABLE C.1 Read Registers (Code 04/03)

HEX BYTE	DESCRIPTION
Byte 1	Slave Address
Byte 2	Function Code
Byte 3	MSB Register Address
Byte 4	LSB Register Address
Byte 5	MSB Number of Registers
Byte 6	LSB Number of Registers
Byte 7	LSB CRC
Byte 8	MSB CRC

The two-byte values of starting register and number of registers to read are transmitted with the high-order byte followed by the low-order byte.

The CRC value is sent with the LSB followed by the MSB.

The following message will obtain the value of register 1 (Modbus 40002) from slave 1. Note that Modbus registers are numbered from zero (40001 = zero, 40002 = one, etc.):

0x01 | 0x03 | 0x00 | 0x01 | 0x00 | 0x01 | 0xD5 | 0xCA

The addressed slave responds with its address and Function Code 3, followed by the information field. The information field contains an 8-bit byte count and the 16-bit data from the slave. The byte count specifies the number of bytes of data in the information field. The data in the information field

consists of 16-bit data arranged so that the MSB is followed by the LSB.

Note: The maximum number of registers per read is 100 (200 bytes).

C.4.3 Write to Register

Function Code 6 or 16 is used to make set-point changes.

C.4.3.1 Write Single Register (Code 6)

The function code format for writing a single register is shown in Table C.2.

The message consists of the slave address followed by the Function Code 6 and two 16-bit values. The first 16-bit value specifies the register to be modified and the second value is the 16-bit data.

Provided no errors occurred, the slave will re-send the original message to the master. The response message is returned only after the command has been executed by the slave.

The following message will set register 3 to 300 in slave 5:

0x05 | 0x06 | 0x00 | 0x03 | 0x01 | 0x2C | 0x78 | 0x03

TABLE C.2 Write Single Register (Code 6)

HEX BYTE	DESCRIPTION
Byte 1	Slave Address
Byte 2	Function Code
Byte 3	MSB Register Address
Byte 4	LSB Register Address
Byte 5	MSB of Data
Byte 6	LSB of Data
Byte 7	LSB of CRC
Byte 8	MSB of CRC

C.4.3.2 Write Multiple Registers (Code 16)

The function-code format in Table C.3 can be used for writing single or multiple registers.

TABLE C.3 Write Multiple Registers (Code 16)

BYTE #	DESCRIPTION
Byte 1	Slave Address
Byte 2	Function Code
Byte 3	MSB Register Address
Byte 4	LSB Register Address
Byte 5	MSB of Quantity
Byte 6	LSB of Quantity
Byte 7	Byte Count
.	MSB of Data
.	LSB of Data
.	LSB of CRC
Byte n	MSB of CRC

The slave will reply with the slave address, function code, register address, and the quantity followed by the CRC code for a total of 8 bytes.

Note: The maximum number of registers per write is 100 (200 bytes).

C.4.4 Command Instruction (Code 5)

Modbus Function Code 5 (Force Single Coil) is used to issue commands to the PGR-7200. The format for the message is listed in Table C.4 and the command code actions and corresponding coil number are listed in Table C.5.

TABLE C.4 Command Format (Code 5)

HEX BYTE	DESCRIPTION
Byte 1	Slave Address
Byte 2	Function Code
Byte 3	MSB of Command Code
Byte 4	LSB of Command Code
Byte 5	Fixed at 0xFF
Byte 6	Fixed at 00
Byte 7	LSB of CRC
Byte 8	MSB of CRC

TABLE C.5 Supported Commands

COMMAND CODE	COIL NUMBER	ACTION
0x0003	4	Reset Trips
0x0004	5	Set Real-Time Clock
0x0005	6	Clear Data-Logging Records
0x0006	7	Clear Trip Counters
0x0008	9	Clear Running Hours
0x0009	10	Emergency I ² t and Trip Reset
0x000D	14	Remote/Net Trip Set
0x000E	15	Remote/Net Trip Clear
0x000F	16	Remote/Net Alarm Set
0x0010	17	Remote/Net Alarm Clear
0x0011	18	Run1 Set
0x0012	19	Run1 Clear

Except for a broadcast address, the slave will return the original packet to the master.

C.4.5 Command Instructions Using Write Commands

For PLC's not supporting Function Code 5, commands can be issued using Write Single Register (Code 6) and Write Multiple Register (Code 16).

Commands are written to PGR-7200 register 6 (Modbus register 40007). Supported commands are listed in the COMMAND CODE column in Table C.5.

When using the Write Multiple Registers function code, the write should be to the single PGR-7200 Register 6. If multiple registers are written starting at PGR-7200 Register 6, the first data element will be interpreted as the command code but no other registers will be written. If the command is successful, the PGR-7200 will return a valid response message.

C.4.6 Exception Responses

The PGR-7200 supports the following exception responses:

- Boundry Error (1)—Applies to writes of 32-bit values. The high-order word must be written first followed by the write to the low-order word. If this sequence is not followed, a Boundry Error is returned and the value will not be stored. This does not apply on read requests.
- Address Error (2)—All accesses to communication registers must be within the specified address range or the Address Error code is returned.
- Command Error (3)—This error code is returned if the command code is not supported.
- Illegal Function Code (4)—The function code (Byte 2) is not supported.

The exception message consists of the slave address followed by a retransmission of the original function code. The function code will have the most-significant bit set to indicate an error. The 8-bit byte following the function code is the exception response code. The 16-bit CRC is at the end of the message.

C.5 PGR-7200 DATABASE

Appendix D contains the Modbus Register in the Communications Database Table. The table starts at register 0 (Modbus 40001) and each register is 16-bits wide. Types "long" and "float" are 32-bit values. For both long and float types, the low-order word is transmitted first followed by the high-order word. Word values have the high byte followed by the low byte. Float types as per IEEE 754 Floating-Point Standard. All bytes of long and float types must be written using one message or an error will result. This does not apply for read commands.

C.5.1 Data Records

Only one event record can be read at a time. Record data is for the record indicated by the Record Selector. To select a record, write the record number to Record Selector and then read the values in the record. Record Head points to the next available record. The last event record captured is at Record Head minus one.

Both Record Selector and Record Head values are in the range of 0 to 99. Values outside this range will select record 0.

C.5.2 Custom Data Access

Data access can be customized with the User-Defined Registers and the User-Data Registers.

User-Defined Registers are located in non-volatile memory and contain the register numbers from which data is required. To access the data, read the corresponding User-Data Registers.

The format of the User Data is a function of the corresponding register entered in the User-Defined-Register area.

C.6 SPECIFICATIONS

Interface.....	Non-Isolated RS/EIA/TIA-232, RJ-45
Protocol.....	Modbus [®] RTU
Baud Rate.....	9,600, 19,200, or 38,400 bit/s
Bit Format.....	8 bits, no parity, one stop bit

Note: A network communication interface has priority over the TIA-232 interface. To minimize TIA-232 errors when both network and TIA-232 communications are used, set the TIA-232 baud rate to 9,600 bit/s.

This page intentionally left blank.

APPENDIX D
COMMUNICATIONS DATABASE TABLE

PGR-7200 REGISTER (DECIMAL)	MODBUS REGISTER (DECIMAL)	DEVICENET (Hex) (NOTE 4)	A-B FILE (DECIMAL) (NOTE 2)	DESCRIPTION	ACCESS	RANGE	TYPE (NOTE 1)
Model Information							
0	40001	01-01-03	3:0	Model Code	Read Only	1302	T3
1	40002	01-01-64	3:1	Software Version	Read Only		T3
2	40003	01-01-06	3:2	Serial Number	Read Only		T2 (low)
3	40004		3:3				T2 (high)
6	40007	29-01-64	3:6	Command Register	Write Only		T72
7	40008	29-01-77	3:7	Set-Point Group	R/W	0 – 1	T81
Overload Group 1							
8	40009	2C-01-64	3:8	I ² t Trip Action	R/W	0 – 7	T42
9	40010	2C-01-65	3:9	I ² t Alarm Action	R/W	0 – 7	T43
11	40012	2C-01-67	3:11	Pickup in per unit of CT rating	R/W	0.1 – 1.25 x I _p	T1 (low)
12	40013		3:12				T1 (high)
15	40016	2C-01-69	3:15	Hot Factor	R/W	0.1 – 1.0	T1 (low)
16	40017		3:16				T1 (high)
17	40018	2C-01-6A	3:17	Cooling Factor	R/W	0.1 – 10	T1 (low)
18	40019		3:18				T1 (high)
19	40020	2C-01-6B	3:19	Time Constant	R/W	1 – 60 min	T1 (low)
20	40021		3:20				T1 (high)
21	40022	2C-01-6C	3:21	I ² t Alarm Level	R/W	0.5 – 1.0	T1 (low)
22	40023		3:22				T1 (high)
Overload Group 2							
26	40027	2C-02-64	3:26	I ² t Trip Action	R/W	0 – 7	T42
27	40028	2C-02-65	3:27	I ² t Alarm Action	R/W	0 – 7	T43
28							
29	40030	2C-02-67	3:29	Pickup in per unit of CT rating	R/W	0.1 – 1.25 x I _p	T1 (low)
30	40031		3:30				T1 (high)
31							
32							
33	40034	2C-02-69	3:33	Hot Factor	R/W	0.1 – 1.0	T1 (low)
34	40035		3:34				T1 (high)
35	40036	2C-02-6A	3:35	Cooling Factor	R/W	0.1 – 10	T1 (low)
36	40037		3:36				T1 (high)
37	40038	2C-02-6B	3:37	Time Constant	R/W	1 – 60 min	T1 (low)
38	40039		3:38				T1 (high)
39	40040	2C-02-6C	3:39	I ² t Alarm Level	R/W	0.5 – 1.0	T1 (low)
40	40041		3:40				T1 (high)
Overload Reset							
44	40045	2C-00-64	3:44	Overload Reset Type	R/W	0 – 2	T38
45	40046	2C-00-65	3:45	Overload Reset Level	R/W	0.1 – 0.9	T1 (low)
46	40047		3:46				T1 (high)



PGR-7200 REGISTER (DECIMAL)	MODBUS REGISTER (DECIMAL)	DEVICENET (Hex) (NOTE 4)	A-B FILE (DECIMAL) (NOTE 2)	DESCRIPTION	ACCESS	RANGE	TYPE (NOTE 1)
Phase Inverse Group 1							
50	40051	69-01-01	3:50	Trip Action	R/W	0 – 7	T42
51	40052	69-01-02	3:51	Curve Type	R/W	0 – 7	T73
52	40053	69-01-03	3:52	Time Multiplier	R/W	0.05 – 1.0	T1(low)
53	40054		3:53				T1(high)
54	40055	69-01-04	3:54	Pickup in pu of CT Rating	R/W	0.1 – 10 x I _p	T1(low)
55	40056		3:55				T1(high)
Phase Inverse Group 2							
60	40061	69-02-01	3:60	Trip Action	R/W	0 – 7	T42
61	40062	69-02-02	3:61	Curve Type	R/W	0 – 7	T73
62	40063	69-02-03	3:62	Time Multiplier	R/W	0.05 – 1.0	T1(low)
63	40064		3:63				T1(high)
64	40065	69-02-04	3:64	Pickup in pu of CT Rating	R/W	0.1 – 10 x I _p	T1(low)
65	40066		3:65				T1(high)
Phase Definite Time Group 1							
70	40071	64-01-01	3:70	Trip Action	R/W	0 – 7	T42
71	40072	64-01-02	3:71	Alarm Action	R/W	0 – 7	T43
72	40073	64-01-03	3:72	Trip Level	R/W	0.1 – 15 x I _p	T1(low)
73	40074		3:73				T1(high)
74	40075	64-01-04	3:74	Trip Delay	R/W	0 – 10 s	T1(low)
75	40076		3:75				T1(high)
76	40077	64-01-05	3:76	Alarm Level	R/W	0.1 – 15 x I _p	T1(low)
77	40078		3:77				T1(high)
78	40079	64-01-06	3:78	Alarm Delay	R/W	0 – 10 s	T1(low)
79	40080		3:79				T1(high)
Phase Definite Time Group 2							
84	40085	64-02-01	3:84	Trip Action	R/W	0 – 7	T42
85	40086	64-02-02	3:85	Alarm Action	R/W	0 – 7	T43
86	40087	64-02-03	3:86	Trip Level	R/W	0.1 – 15 x I _p	T1(low)
87	40088		3:87				T1(high)
88	40089	64-02-04	3:88	Trip Delay	R/W	0 – 10 s	T1(low)
89	40090		3:89				T1(high)
90	40091	64-02-05	3:90	Alarm Level	R/W	0.1 – 15 x I _p	T1(low)
91	40092		3:91				T1(high)
92	40093	64-02-06	3:92	Alarm Delay	R/W	0 – 10 s	T1(low)
93	40094		3:93				T1(high)
Earth-Fault 3I₀ Inverse Group 1							
100	40101	69-03-01	3:100	Trip Action	R/W	0 – 7	T42
101	40102	69-03-02	3:101	Curve Type	R/W	0 – 7	T73
102	40103	69-03-03	3:102	Time Multiplier	R/W	0.05 – 1.0	T1(low)
103	40104		3:103				T1(high)
104	40105	69-03-04	3:104	Pickup in pu of CT Rating	R/W	0.1 – 10 x I _p	T1(low)
105	40106		3:105				T1(high)

PGR-7200 REGISTER (DECIMAL)	MODBUS REGISTER (DECIMAL)	DEVICENET (Hex) (NOTE 4)	A-B FILE (DECIMAL) (NOTE 2)	DESCRIPTION	ACCESS	RANGE	TYPE (NOTE 1)
Earth-Fault 3I₀ Inverse Group 2							
110	40111	69-04-01	3:110	Trip Action	R/W	0 – 7	T42
111	40112	69-04-02	3:111	Curve Type	R/W	0 – 7	T73
112	40113	69-04-03	3:112	Time Multiplier	R/W	0.05 – 1.0	T1(low)
113	40114		3:113				T1(high)
114	40115	69-04-04	3:114	Pickup in pu of CT Rating	R/W	0.1 – 10 x I _p	T1(low)
115	40116		3:115				T1(high)
Earth-Fault 3I₀ Definite Time Group 1							
120	40121	64-03-01	3:120	Trip Action	R/W	0 – 7	T42
121	40122	64-03-02	3:121	Alarm Action	R/W	0 – 7	T43
122	40123	64-03-03	3:122	Trip Level	R/W	0.1 – 15 x I _p	T1(low)
123	40124		3:123				T1(high)
124	40125	64-03-04	3:124	Trip Delay	R/W	0 – 10 s	T1(low)
125	40126		3:125				T1(high)
126	40127	64-03-05	3:126	Alarm Level	R/W	0.1 – 15 x I _p	T1(low)
127	40128		3:127				T1(high)
128	40129	64-03-06	3:128	Alarm Delay	R/W	0 – 10 s	T1(low)
129	40130		3:129				T1(high)
Earth-Fault 3I₀ Definite Time Group 2							
136	40137	64-04-01	3:136	Trip Action	R/W	0 – 7	T42
137	40138	64-04-02	3:137	Alarm Action	R/W	0 – 7	T43
138	40139	64-04-03	3:138	Trip Level	R/W	0.1 – 15 x I _p	T1(low)
139	40140		3:139				T1(high)
140	40141	64-04-04	3:140	Trip Delay	R/W	0 – 10 s	T1(low)
141	40142		3:141				T1(high)
142	40143	64-04-05	3:142	Alarm Level	R/W	0.1 – 15 x I _p	T1(low)
143	40144		3:143				T1(high)
144	40145	64-04-06	3:144	Alarm Delay	R/W	0 – 10 s	T1(low)
145	40146		3:145				T1(high)
Earth-Fault CT-Input Definite Time Group 1							
150	40151	64-05-01	3:150	Trip Action	R/W	0 – 7	T42
151	40152	64-05-02	3:151	Alarm Action	R/W	0 – 7	T43
152	40153	64-05-03	3:152	Trip Level	R/W	0.01 – 1.0 x I _e	T1(low)
153	40154		3:153				T1(high)
154	40155	64-05-04	3:154	Trip Delay	R/W	0 – 100 s	T1(low)
155	40156		3:155				T1(high)
156	40157	64-05-05	3:156	Alarm Level	R/W	0.01 – 1.0 x I _e	T1(low)
157	40158		3:157				T1(high)
158	40159	64-05-06	3:158	Alarm Delay	R/W	0 – 100 s	T1(low)
159	40160		3:159				T1(high)

PGR-7200 REGISTER (DECIMAL)	MODBUS REGISTER (DECIMAL)	DEVICENET (Hex) (NOTE 4)	A-B FILE (DECIMAL) (NOTE 2)	DESCRIPTION	ACCESS	RANGE	TYPE (NOTE 1)
Earth-Fault CT-Input Definite Time Group 2							
166	40167	64-06-01	3:166	Trip Action	R/W	0 – 7	T42
167	40168	64-06-02	3:167	Alarm Action	R/W	0 – 7	T43
168	40169	64-06-03	3:168	Trip Level	R/W	0.01 – 1.0 x I _e	T1(low)
169	40170		3:169				T1(high)
170	40171	64-06-04	3:170	Trip Delay	R/W	0 – 100 s	T1(low)
171	40172		3:171				T1(high)
172	40173	64-06-05	3:172	Alarm Level	R/W	0.01 – 1.0 x I _e	T1(low)
173	40174		3:173				T1(high)
174	40175	64-06-06	3:174	Alarm Delay	R/W	0 – 100 s	T1(low)
175	40176		3:175				T1(high)
Current Unbalance							
180	40181	64-07-01	3:180	Trip Action	R/W	0 – 7	T42
181	40182	64-07-02	3:181	Alarm Action	R/W	0 – 7	T43
182	40183	64-07-03	3:182	Trip Level	R/W	0.05 – 1.0	T1(low)
183	40184		3:183				T1(high)
184	40185	64-07-04	3:184	Trip Delay	R/W	1 – 100 s	T1(low)
185	40186		3:185				T1(high)
186	40187	64-07-05	3:186	Alarm Level	R/W	0.05 – 1.0	T1(low)
187	40188		3:187				T1(high)
188	40189	64-07-06	3:188	Alarm Delay	R/W	1 – 100 s	T1(low)
189	40190		3:189				T1(high)
Phase Reverse							
192	40193	64-08-01	3:192	Trip Action	R/W	0 – 7	T42
193	40194	64-08-02	3:193	Alarm Action	R/W	0 – 7	T43
194	40195	64-08-04	3:194	Trip Delay	R/W	1 – 100 s	T1(low)
195	40196		3:195				T1(high)
196	40197	64-08-06	3:196	Alarm Delay	R/W	1 – 100 s	T1(low)
197	40198		3:197				T1(high)
Phase Loss							
198	40199	64-09-01	3:198	Trip Action	R/W	0 – 7	T42
199	40200	64-09-02	3:199	Alarm Action	R/W	0 – 7	T43
200	40201	64-09-04	3:200	Trip Delay	R/W	1 – 100 s	T1(low)
201	40202		3:201				T1(high)
202	40203	64-09-06	3:202	Alarm Delay	R/W	1 – 100 s	T1(low)
203	40204		3:203				T1(high)
Remote/Network Trip							
230	40231	29-01-81	3:230	Trip Action	R/W	0 – 7	T42
231	40232	29-01-82	3:231	Alarm Action	R/W	0 – 7	T43

PGR-7200 REGISTER (DECIMAL)	MODBUS REGISTER (DECIMAL)	DEVICENET (Hex) (NOTE 4)	A-B FILE (DECIMAL) (NOTE 2)	DESCRIPTION	ACCESS	RANGE	TYPE (NOTE 1)
System Ratings							
250	40251	29-01-87	3:250	Frequency	R/W	0 – 1	T10
251	40252	29-01-85	3:251	Phase CT Primary	R/W	1 – 5,000 A	T1(low)
252	40253		3:252				T1(high)
253	40254	29-01-86	3:253	Earth-Fault CT Primary	R/W	1 – 5,000 A	T1(low)
254	40255		3:254				T1(high)
255	40256	29-01-95	3:255	Unbalance Current Threshold	R/W	0.1 – 0.5 x I _p	T1(low)
256	40257		3:256				T1(high)
Operator Interface							
270	40271	29-01-7D	3:270	Display-Loss Trip Action	R/W	0 – 7	T42
271	40272	01-01-67	3:271	Password Timeout	R/W	1 – 60 min	T1(low)
272	40273		3:272				T1(high)
273	40274	29-01-84	3:273	UPI LED Assignment	R/W	0 – 17	T74
274	40275		3:274	Default Menu	R/W	0 - 9	T97
Digital Input							
280	40281	29-01-76	3:280	Function	R/W	0 – 4	T75
281	40282	29-01-79	3:281	Trip Delay	R/W	0.01 – 100 s	T1(low)
282	40283		3:282				T1(high)
Relay Output Function							
334	40335	29-01-6F	3:334	Relay 1 Output Function	R/W	0 – 12	T76
335	40336	29-01-70	3:335	Relay 1 Mode	R/W	0 – 1	T14
336	40337	29-01-71	3:336	Relay 2 Output Function	R/W	0 – 12	T76
337	40338	29-01-72	3:337	Relay 2 Mode	R/W	0 – 1	T14
338	40339	29-01-73	3:338	Relay 3 Output Function	R/W	0 – 12	T76
339	40340	29-01-74	3:339	Relay 3 Mode	R/W	0 – 1	T14
340	40341	29-01-75	3:340	Relay Pulse Time	R/W	0.05 – 10 s	T1(low)
341	40342		3:341				T1(high)
Analog Output							
372	40373	29-01-7B	3:372	Analog Output Parameter	R/W	0 – 11	T77
Network Communication							
374	40375	05-00-65	3:374	DeviceNet Producing Instance	R/W	0 – 5	T84
375	40376	05-00-64	3:375	DeviceNet Consuming Instance	R/W	0 – 2	T85
376	40377		3:376	Network Type	R/W	0 – 6	T65
377	40378		3:377	Network Baud	R/W	0 – 5	T69
378	40379		3:378	Network Error Check	R/W	0 – 2	T18
379	40380		3:379	Network ID (Slave ID)	R/W	0 – 255	T1(low)
380	40381		3:380				T1(high)
381	40382	03-01-64	3:381	Network Trip Action	R/W	0 – 7	T42
382	40383	03-01-65	3:382	Network Alarm Action	R/W	0 – 7	T43
Local TIA-232 Communication							
383	40384		3:383	TIA-232 Baud Rate	R/W	0 – 2	T66
384	40385		3:384	TIA-232 ID	R/W	0 – 255	T1(low)
385	40386		3:385				T1(high)

PGR-7200 REGISTER (DECIMAL)	MODBUS REGISTER (DECIMAL)	DEVICENET (Hex) (NOTE 4)	A-B FILE (DECIMAL) (NOTE 2)	DESCRIPTION	ACCESS	RANGE	TYPE (NOTE 1)
RTD Sensor							
388	40389	29-01-96	3:388	RTD-Sensor-Error Trip Action	R/W	0 – 7	T42
389	40390	29-01-97	3:389	RTD-Sensor-Error Alarm Action	R/W	0 – 7	T43
PTC Temperature							
560	40561	29-01-7F	4:170	Temperature Sensor Type	R/W	0 – 2	T68
561	40562	64-0A-01	4:171	Trip Action	R/W	0 – 7	T42
562	40563	64-0A-02	4:172	Alarm Action	R/W	0 – 7	T43
RTD Temperature							
563	40564	64-0B-01	4:173	Trip Action	R/W	0 – 7	T42
564	40565	64-0B-03	4:174	Trip Level	R/W	40 – 230 °C	T1(low)
565	40566		4:175				T1(high)
566	40567	64-0B-05	4:176	Alarm Level	R/W	40 – 230 °C	T1(low)
567	40568		4:177				T1(high)
568	40569	64-0B-02	4:178	Alarm Action	R/W	0 – 7	T43
Real Time Clock Reading							
574	40575	66-01-01	5:0	RTC Date	Read Only		T23(low)
575	40576		5:1				T23(high)
576	40577	66-01-02	5:2	RTC Time	Read Only		T24(low)
577	40578		5:3				T24(high)
Character Strings (10 words, 20 characters)							
580	40581	66-01-03	5:6	Clock Setting	R/W		T31
590	40591	01-01-66	5:16	Password Setting, (4 characters)	R/W		T22
600	40601	01-01-65	5:26	System Name	R/W		T22
Analog Output Calibration							
856	40857		5:282	Zero Calibration Value	R/W	0-1,000	T1(low)
857	40858		5:283				T1(high)
858	40859		5:284	Full-Scale Calibration Value	R/W	0-1,000	T1(low)
859	40860		5:285				T1(high)
Meter Values							
860	40861	29-01-88	6:0	I _a (A)	Read Only		T1(low)
861	40862		6:1				T1(high)
862	40863	29-01-89	6:2	I _b (A)	Read Only		T1(low)
863	40864		6:3				T1(high)
864	40865	29-01-8A	6:4	I _c (A)	Read Only		T1(low)
865	40866		6:5				T1(high)
866	40867	29-01-8B	6:6	Earth Leakage from CT (A)	Read Only		T1(low)
867	40868		6:7				T1(high)
868	40869	29-01-8C	6:8	Earth Leakage 3I ₀ (A)	Read Only		T1(low)
869	40870		6:9				T1(high)
870	40871	29-01-8D	6:10	Positive-Sequence Current (pu)	Read Only		T1(low)
871	40872		6:11				T1(high)

PGR-7200 REGISTER (DECIMAL)	MODBUS REGISTER (DECIMAL)	DEVICENET (Hex) (NOTE 4)	A-B FILE (DECIMAL) (NOTE 2)	DESCRIPTION	ACCESS	RANGE	TYPE (NOTE 1)
Status							
1096	41097	29-01-65	8:0	Trip and Alarm Summary	Read Only		T67
1097	41098	29-01-66	8:1	PGR-7200 Status	Read Only		T78
Trip-and-Alarm Bit Details							
1104	41105	29-01-67	8:8	Bits 0..15 (Bit 0 LSB, Bit 15 MSB) ⁽⁹⁾	Read Only		T45
1105	41106	29-01-68	8:9	Bits 16..31	Read Only		T46
1106	41107	29-01-69	8:10	Bits 32..47	Read Only		T47
1107	41108	29-01-6A	8:11	Bits 48..63	Read Only		T48
1108	41109	29-01-6B	8:12	Bits 64..79	Read Only		T49
1109	41110	29-01-6C	8:13	Bits 80..95	Read Only		T50
1110	41111	29-01-6D	8:14	Bits 96..111	Read Only		T51
1111	41112	29-01-6E	8:15	Bits 112..127	Read Only		T52
Trip Counters							
1130	41131	2C-01-6D	8:34	Overload Group 1	Read Only		T3
1131	41132	2C-02-6D	8:35	Overload Group 2	Read Only		T3
1132	41133	69-01-05	8:36	Phase Inverse Group 1	Read Only		T3
1133	41134	69-02-05	8:37	Phase Inverse Group 2	Read Only		T3
1134	41135	64-01-07	8:38	Phase Definite Time Group 1	Read Only		T3
1135	41136	64-02-07	8:39	Phase Definite Time Group 2	Read Only		T3
1136	41137	69-03-05	8:40	EF 3I ₀ Inverse Group 1	Read Only		T3
1137	41138	69-04-05	8:41	EF 3I ₀ Inverse Group 2	Read Only		T3
1138	41139	64-03-07	8:42	3I ₀ Definite Time Group 1	Read Only		T3
1139	41140	64-04-07	8:43	3I ₀ Definite Time Group 2	Read Only		T3
1140	41141	64-05-07	8:44	EF CT Definite Time Group 1	Read Only		T3
1141	41142	64-06-07	8:45	EF CT Definite Time Group 2	Read Only		T3
1142	41143	64-07-07	8:46	Current Unbalance	Read Only		T3
1143	41144	64-08-07	8:47	Phase Reverse	Read Only		T3
1144	41145	64-09-07	8:48	Phase Loss	Read Only		T3
1145	41146	29-01-7A	8:49	Digital Input	Read Only		T3
1146	41147	64-0B-07	8:50	RTD Temperature	Read Only		T3
1147	41148	64-0A-07	8:51	PTC	Read Only		T3
1148	41149	29-01-80	8:52	RTD Sensor	Read Only		T3
1184	41185		8:88	Non-Volatile Enum Error	Read Only		T3
1185	41186		8:89	Non-Volatile Number Error	Read Only		T3
1186	41187		8:90	Non-Volatile String Error	Read Only		T3
1187	41188		8:91	Non-Volatile Event Record Error	Read Only		T3
1188	41189		8:92	Non-Volatile Thermal Error	Read Only		T3
1189	41190	29-01-7E	8:93	Operator Interface Error	Read Only		T3
1190	41191		8:94	DSP Error	Read Only		T3
1191	41192	3-01-66	8:95	Communication Fault	Read Only		T3
1192	41193	29-01-83	8:96	Remote Trip	Read Only		T3

PGR-7200 REGISTER (DECIMAL)	MODBUS REGISTER (DECIMAL)	DEVICENET (Hex) (NOTE 4)	A-B FILE (DECIMAL) (NOTE 2)	DESCRIPTION	ACCESS	RANGE	TYPE (NOTE 1)
Ethernet							
1280	41281		9:70	IP Address	R/W		T22
1290	41291		9:80	Address Mask	R/W		T22
1300	41301		9:90	Gateway Address	R/W		T22
1310	41311		9:100	MAC Address	Read Only		T22
User-Defined Registers							
1400	41401	67-01-01	9:190	User Register 0	R/W		T3
1401	41402	67-01-02	9:191	User Register 1	R/W		T3
1402	41403	67-01-03	9:192	User Register 2	R/W		T3
1403	41404	67-01-04	9:193	User Register 3	R/W		T3
1404	41405	67-01-05	9:194	User Register 4	R/W		T3
1405	41406	67-01-06	9:195	User Register 5	R/W		T3
1406	41407	67-01-07	9:196	User Register 6	R/W		T3
1407	41408	67-01-08	9:197	User Register 7	R/W		T3
1408	41409	67-01-09	9:198	User Register 8	R/W		T3
1409	41410	67-01-0A	9:199	User Register 9	R/W		T3
1410	41411	67-01-0B	9:200	User Register 10	R/W		T3
1411	41412	67-01-0C	9:201	User Register 11	R/W		T3
1412	41413	67-01-0D	9:202	User Register 12	R/W		T3
1413	41414	67-01-0E	9:203	User Register 13	R/W		T3
1414	41415	67-01-0F	9:204	User Register 14	R/W		T3
1415	41416	67-01-10	9:205	User Register 15	R/W		T3
1416	41417	67-01-11	9:206	User Register 16	R/W		T3
1417	41418	67-01-12	9:207	User Register 17	R/W		T3
1418	41419	67-01-13	9:208	User Register 18	R/W		T3
1419	41420	67-01-14	9:209	User Register 19	R/W		T3
1420	41421	67-01-15	9:210	User Register 20	R/W		T3
1421	41422	67-01-16	9:211	User Register 21	R/W		T3
1422	41423	67-01-17	9:212	User Register 22	R/W		T3
1423	41424	67-01-18	9:213	User Register 23	R/W		T3
1424	41425	67-01-19	9:214	User Register 24	R/W		T3
1425	41426	67-01-1A	9:215	User Register 25	R/W		T3
1426	41427	67-01-1B	9:216	User Register 26	R/W		T3
1427	41428	67-01-1C	9:217	User Register 27	R/W		T3
1428	41429	67-01-1D	9:218	User Register 28	R/W		T3
1429	41430	67-01-1E	9:219	User Register 29	R/W		T3
1430	41431	67-01-1F	9:220	User Register 30	R/W		T3
1431	41432	67-01-20	9:221	User Register 31	R/W		T3

PGR-7200 REGISTER (DECIMAL)	MODBUS REGISTER (DECIMAL)	DEVICENET (Hex) (NOTE 4)	A-B FILE (DECIMAL) (NOTE 2)	DESCRIPTION	ACCESS	RANGE	TYPE (NOTE 1)
User Data							
1432	41433		9:222	User Register 0 Data	Read Only	<i>Range and Type defined by user register value</i>	
1433	41434		9:223	User Register 1 Data	Read Only		
1434	41435		9:224	User Register 2 Data	Read Only		
1435	41436		9:225	User Register 3 Data	Read Only		
1436	41437		9:226	User Register 4 Data	Read Only		
1437	41438		9:227	User Register 5 Data	Read Only		
1438	41439		9:228	User Register 6 Data	Read Only		
1439	41440		9:229	User Register 7 Data	Read Only		
1440	41441		9:230	User Register 8 Data	Read Only		
1441	41442		9:231	User Register 9 Data	Read Only		
1442	41443		9:232	User Register 10 Data	Read Only		
1443	41444		9:233	User Register 11 Data	Read Only		
1444	41445		9:234	User Register 12 Data	Read Only		
1445	41446		9:235	User Register 13 Data	Read Only		
1446	41447		9:236	User Register 14 Data	Read Only		
1447	41448		9:237	User Register 15 Data	Read Only		
1448	41449		9:238	User Register 16 Data	Read Only		
1449	41450		9:239	User Register 17 Data	Read Only		
1450	41451		9:240	User Register 18 Data	Read Only		
1451	41452		9:241	User Register 19 Data	Read Only		
1452	41453		9:242	User Register 20 Data	Read Only		
1453	41454		9:243	User Register 21 Data	Read Only		
1454	41455		9:244	User Register 22 Data	Read Only		
1455	41456		9:245	User Register 23 Data	Read Only		
1456	41457		9:246	User Register 24 Data	Read Only		
1457	41458		9:248	User Register 25 Data	Read Only		
1458	41459		9:248	User Register 26 Data	Read Only		
1459	41460		9:249	User Register 27 Data	Read Only		
1460	41461		9:250	User Register 28 Data	Read Only		
1461	41462		9:251	User Register 29 Data	Read Only		
1462	41463		9:252	User Register 30 Data	Read Only		
1463	41464		9:253	User Register 31 Data	Read Only		

Notes:

- (1) See Appendix E, Register Formats.
- (2) The A-B File is coded as FILE:ELEMENT. To read or write the element as floats, the PLC 5 or SLC 500 address would be <F><FILE>:<ELEMENT> (Example F9:222). To read or write the element as integers using PLC 5 Typed Read and Typed Write commands, add 20 to the file number and precede with N, <N><FILE+20>:<ELEMENT> (Example N29:222). File offset is not required for the SLC 500 Protected Typed Logical Read and Write commands. See PGR-7200 TIA-485 Network Manual.
- (3) The bit number corresponds to the T79 Message Code. The LSB corresponds to the lower message code in the 16-bit number.
- (4) Designation is Class – Instance –Attribute.

APPENDIX E
REGISTER FORMATS

TYPE	C TYPE	DESCRIPTION ⁽¹⁾
T1	float	IEEE 32-Bit Floating-Point Number
		Bit 31: Sign
		Bits 30..23: Exponent
		Bits 22..0: Mantissa
		(high): Bits 31..16 (low): Bits 15..0
T2	long	32-Bit Integer
		(high) Bits 31..16
		(low) Bits 15..0
T3	short	16-Bit Integer
T6	short	Enable/Disable
		0: Enabled
		1: Disabled
T10	short	Frequency
		0: 50 Hz
		1: 60 Hz
T14	short	Relay Trip/Alarm Mode
		0: Fail Safe
		1: Non Fail Safe
T18	short	Error Checking (AB DF1 only)
		0: Not Selected
		1: CRC Check
		2: BCC Check
T22	char	20 ASCII Characters
		Register +0: char[0] and char[1]. Char[0] at MSByte
		Register +1: char[2] and char[3]. Char[2] at MSByte
		Register +2: char[4] and char[5]. Char[4] at MSByte
		Register +3: char[6] and char[7]. Char[6] at MSByte
		Register +4: char[8] and char[9]. Char[8] at MSByte
		Register +5: char[10] and char[11]. Char[10] at MSByte
		Register +6: char[12] and char[13]. Char[12] at MSByte
		Register +7: char[14] and char[15]. Char[14] at MSByte
		Register +8: char[16] and char[17]. Char[16] at MSByte
		Register +9: char[18] and char[19]. Char[18] at MSByte
		A character value of 0 (Null) will terminate the string and the following characters will be ignored
		Ethernet address strings are of the form: "ddd.ddd.ddd.ddd". The MAC address is a hex string of the form: "hhhhhhhhhhhh"

TYPE	C TYPE	DESCRIPTION ⁽¹⁾
T23	long	Date
		Bits 31..16: year in binary
		Bits 15..8: 1-12 months in binary
		Bits 7..0: 1-31 days in binary
T24	long	Time
		Bits 31..24: 0-23 hours in binary
		Bits 23..16: 0-60 minutes in binary
		Bits 15..8: 0-60 seconds in binary
		Bits 7..0: 0-99 hundredths of a second in binary
T31	char	RTC ASCII-Character Setting String:
		YY/MM/DD HH:mm:SS
		YY: 2-digit Year (Year 2000 – 2099)
		MM: Month 1-12
		DD: Day 1-31
		HH: Hour 0-23
		mm: Minute 0-59
		SS: Seconds 0-59
		RTC is updated when "Set RTC" command is issued
T32	Short	Free Record Pointer. Subtract one to obtain last record. Range is 0 to 99.
T38	short	Overload Reset Type
		0: Normal
		1: Autoreset
		2: Rapid
T42	short	Trip Action
		0: Disabled
		1: Trip1
		2: Trip2
		3: Trip3
		4: Trip1 & Trip2
		5: Trip1 & Trip3
		6: Trip1 & Trip2 & Trip3
7: Trip2 & Trip3		

TYPE	C TYPE	DESCRIPTION ⁽¹⁾
T43	short	Alarm Action
		0: Disabled
		1: Alarm1
		2: Alarm2
		3: Alarm3
		4: Alarm1 & Alarm2
		5: Alarm1 & Alarm3
		6: Alarm1 & Alarm2 & Alarm3
		7: Alarm2 & Alarm3
T45	short	Trip/Alarm Message Code Bits ⁽³⁾ 15..0
T46	short	Trip/Alarm Message Code Bits ⁽³⁾ 31..16
T47	short	Trip/Alarm Message Code Bits ⁽³⁾ 47..32
T48	short	Trip/Alarm Message Code Bits ⁽³⁾ 63..48
T49	short	Trip/Alarm Message Code Bits ⁽³⁾ 79..64
T50	short	Trip/Alarm Message Code Bits ⁽³⁾ 95..80
T51	short	Trip/Alarm Message Code Bits ⁽³⁾ 111..96
T52	short	Trip/Alarm Message Code Bits ⁽³⁾ 127..112
T65	short	Network Communication Type
		0: None
		1: A-B DF1
		2: DeviceNet
		3: Reserved
		4: Modbus RTU
		5: Modbus TCP
		6: Reserved
T66	short	Local Communication Baud Rates
		0: 9,600 bit/s
		1: 19,200 bit/s
		2: 38,400 bit/s
T67	short	Trip and Alarm Summary
		Bit0: 0
		Bit1: 0
		Bit2: 0
		Bit3: 0
		Bit4: Trip1
		Bit5: Trip2
		Bit6: Trip3
		Bit7: Alarm1
		Bit8: Alarm2
Bit9: Alarm3		

TYPE	C TYPE	DESCRIPTION ⁽¹⁾
T67		Bit10: 0
		Bit11: 0
		Bit12: 0
		Bit13: 0
		Bit14: 0
		Bit15: 0
T68	Short	Temperature Sensor Type
		0: Disabled
		1: RTD Sensor
		2: PTC Sensor
T69	short	Network Baud Rate
		0: TIA 9,600 bit/s
		1: TIA 19,200 bit/s
		2: TIA 38,400 bit/s
		3: DeviceNet 125 kbit/s
		4: DeviceNet 250 kbit/s
T72	short	Communications Command
		0: Reserved
		1: Reserved
		2: Reserved
		3: Reset Trips (All except Remote/Network Trips)
		4: Set RTC
		5: Clear Data-Logging Records
		6: Clear Trip Counters
		7: Reserved
		8: Clear Running Hours
		9: Emergency Thermal Reset
		10: Reserved
		11: Reserved
		12: Re-enable Temperature Protection
		13: Remote/Network Trip Set
		14: Remote/Network Trip Reset
		15: Remote/Network Alarm Set
		16: Remote/Network Alarm Reset
		17: Run1 Set
18: Run1 Clear		

TYPE	C TYPE	DESCRIPTION ⁽¹⁾
T73	Short	Inverse Time Curve
		0: IEC Normal Inverse A
		1: IEC Very Inverse B
		2: IEC Extreme Inverse C
		3: IEC Short Inverse A
		4: IEC Long Inverse B
		5: IEEE Moderate Inverse
		6: IEEE Very Inverse
		7: IEEE Extreme Inverse
T74	Short	User Programmable Indicator
		0: None (LED Off)
		1: Trip1
		2: Trip2
		3: Trip3
		4: Alarm1
		5: Alarm2
		6: Alarm3
		7: Relay 1
		8: Relay 2
		9: Relay 3
		10: Digital Input
		11: Current Detected
		12: 3I ₀ Pickup
		13: Phase Pickup
		14: ETR State
		15: Reserved
16: Network Run1		
17: Net Activity		
T75	Short	Digital Input Function
		0: None
		1: Trip1
		2: Reset
		3: Program Enable
		4: Set-Point Group 2 Select

TYPE	C TYPE	DESCRIPTION ⁽¹⁾
T76	short	Relay Output Function
		0: None (Relay De-energized)
		1: Trip1
		2: Trip2
		3: Trip3
		4: Alarm1
		5: Alarm2
		6: Alarm3
		7: Current Detected
		8: Reserved
		9: Reserved
		10: Trip1 Pulse
		11: Watchdog
12: Network Run1		
T77	Short	Analog Output Function
		0: Phase Current
		1: EF (I_{ct} Measured)
		2: EF ($3I_0$ Calculated)
		3: Used I^2t
		4: Reserved
		5: Rerved
		6: Reserved
		7: Reserved
		8: Reserved
		9: Unbalance
		10: Zero (4 mA)
11: Full Scale (20 mA)		
T78	Short	PGR-7200 Status
		Bit0: 1 = Current > Threshold
		Bit1: 1 = $3I_0$ Inverse Curve Picked Up
		Bit2: 1 = Ph Inverse Curve Picked Up
		Bit3: 0
		Bit4: 1 = ETR On
		Bit5: 1 = PTC Open
		Bit6: 0
		Bit7: 0
		Bit8: 1 = Digital Input Valid
		Bit9: 1 = Relay 1 Energized
		Bit10: 1 = Relay 2 Energized
Bit11: 1 = Relay 3 Energized		

TYPE	C TYPE	DESCRIPTION ⁽¹⁾
T79	Short	Trip Code
		0: Overload Trip Group 1
		1: Overload Trip Group 2
		2: Overload Alarm Group 1
		3: Overload Alarm Group 2
		4: Phase Inverse O/C Trip Group 1
		5: Phase Inverse O/C Trip Group 2
		6: Phase Timed O/C Trip Group 1
		7: Phase Timed O/C Trip Group 2
		8: Phase Timed O/C Alarm Group 1
		9: Phase Timed O/C Alarm Group 2
		10: 3I ₀ Inverse Trip Group 1
		11: 3I ₀ Inverse Trip Group 2
		12: 3I ₀ Timed Trip Group 1
		13: 3I ₀ Timed Trip Group 2
		14: 3I ₀ Timed Alarm Group 1
		15: 3I ₀ Timed Alarm Group 2
		16: EFCT Timed Trip Group 1
		17: EFCT Timed Trip Group 2
		18: EFCT Timed Alarm Group 1
		19: EFCT Timed Alarm Group 2
		20: Unbalance Trip
		21: Unbalance Alarm
		22: Phase Loss Trip
		23: Phase Loss Alarm
		24: Phase Reverse Trip
		25: Phase Reverse Alarm
		26 to 29: Reserved
		30: Digital Input Trip
		31: RTD Trip
		32: RTD Alarm
		33: RTD Sensor Trip
		34: RTD Sensor Alarm
		35: PTC Trip
		36: PTC Alarm
		37 to 93: Reserved
		94: Memory Error. All defaults loaded
		95: Memory Error. Enumeration
		96: Memory Error. Numeric
		97: Memory Error. String
		98: Memory Error. Records1
		99: Memory Error. Records2
		100: Display Error
		101: Reserved

TYPE	C TYPE	DESCRIPTION ⁽¹⁾
T79		102: DSP Error
		103: Network Comm Trip
		104: Network Comm Alarm
		105: Remote Trip Via Network
		106: Remote Alarm Via Network
		107 to 127: Reserved
		252: ETR Request ⁽²⁾
		255: No Trip or Alarm
T80	Short	Record Type
		0: Empty Record
		1: Trip Record
		3: ETR Record
T81	Short	Set-Point Group
		0: Group 1
		1: Group 2
T84	Short	DeviceNet Producing Instance
		0: None
		1: 0x32 Basic Overload
		2: 0x33 Extended Overload
		3: 0x34 Basic Motor Starter
		4: 0x35 Extended Motor Starter1
	5: 0x64 User Registers	
T85	Short	DeviceNet Consuming Instance
		0: None
		1: 0x02 Basic Overload
	2: 0x03 Basic Motor Starter	
T97	Short	Default Menu
		0: Main
		1: Current
		2: Unbalance
		3: Earth Leakage
		4: Thermal Status
		5: Inverse Status
		6: Load Sensor
		7: I/O Status
		8: System Status
	9: Network Status	

Notes:

- ⁽¹⁾ All values are integers unless indicated by "Bit x", where x represents bit location and 0 = LSB.
- ⁽²⁾ Not a trip code. Used by event records to indicate special type.
- ⁽³⁾ The bit number corresponds to the T79 Message Code. The LSB corresponds to the lower message code in the 16-bit number.

