

# SOLUTIONS TECH BRIEF

Technical solutions on circuit protection from Littelfuse, Inc.

Brief No. 98-004

## The Littelfuse Skiving Operation

Littelfuse's skiving operation is an important part of the company's manufacturing process. This operation, unique to Littelfuse, contributes to the high quality of Littelfuse products by ensuring tight fuse element resistance control and providing highly predictable fuse opening characteristics.

Littelfuse products that utilize the skiving operation during manufacturing include the ATO® Fuse, MINI® Fuse, MAXI™ Fuse, MEGA® Fuse and JCASE™ Cartridge Fuse. MIDI® Fuses and PALs™ (Pacific Auto Links) are not manufactured with skiving.

### The Spread of Resistance

Resistance is the opposition to current flow. Regarding fuse elements, resistance controls the opening characteristics of the fuse. Resistance is measured in ohms,

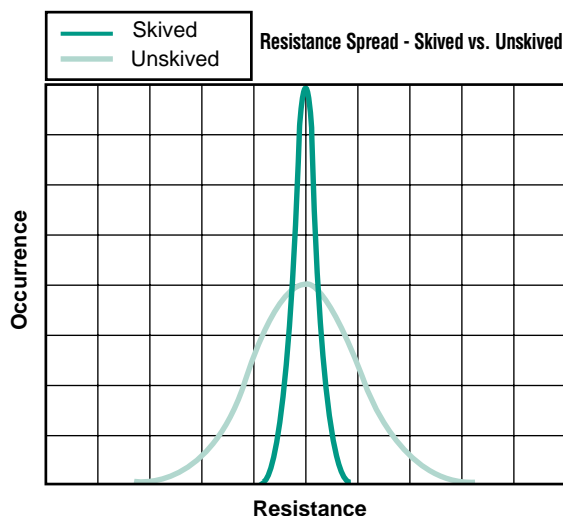

and equals voltage divided by current (resistance = voltage/current). The nature of the material used in fuse manufacturing and the way it is processed create variations in resistance. This spread of resistance could cause fuse elements to be less accurate, providing a wide window of opening times and

making fuses less predictable. Since fuses are used for protection, a wide spread of resistance is not acceptable, because it makes designing protection for circuits more difficult for the circuit designers. A wide spread of resistance could also present a hazard when the fuse is in use because it may not open at the expected times. Littelfuse solves this problem by reducing the spread of resistance with skiving.

Fuse elements for Littelfuse circuit protection products are stamped from a strip of zinc material. Two main factors of this material contribute to the spread of resistance:

- Changes in the zinc alloy can create variations in resistivity, a natural characteristic of the material which equals the resistance per unit length of the material. Resistivity of the material directly affects the resistance of the fuse element.
- The thickness of the strip of zinc varies as it comes from the foundry. The thickness of the material also directly affects the resistance of the fuse element.

These variations significantly impact the point at which a fuse will blow because they affect resistance. Skiving enables Littelfuse to produce fuses that have much less variation within the same fuse rating, thus ensuring higher accuracy.

### Determining Resistance

The resistance of electrically conductive material is determined by the formula:  $R = \rho L/A$ . In this equation,  $\rho$  is the resistivity,  $L$  is the length of the material, and  $A$  is the area of material cross-section.  $A$  is determined by the thickness  $T$  and width  $W$  of the cross-section area.

## The Effect of Resistance on Opening Characteristics

Current flow and a material's resistance to the current generate heat. This heat melts the fuse element and causes the fuse to open or "blow." Controlling resistance through skiving allows Littelfuse to determine when the heat will be generated, thus allowing control over the opening characteristics of the fuse.

With skiving, Littelfuse alters the resistance of the fuse by changing the geometry of the fuse element. The thickness of the fuse (T in the formula outlined in "Determining Resistance") is the most effective parameter to adjust for tight resistance control.

A thinner fuse provides higher resistance, and therefore it takes less current to melt it. Conversely, a thicker fuse element has lower resistance, which takes more current to melt the fuse element and open the fuse. As the fuse rating increases, resistance decreases. Skiving enables Littelfuse to more accurately determine a fuse element's thickness to reduce the window during which a fuse will open.

## The Skiving Operation in Manufacturing

Littelfuse's unique skiving process, patented in 1977, was developed specifically for the manufacture of automotive fuses. Littelfuse accurately controls the thickness and resistance of the fuse element by using the skiving operation during the manufacturing process.

Fuse elements are manufactured from a strip of zinc material. Skiving is the removal of a precise amount of zinc from the strip of the material. The zinc starts out as a single continuous coil. During the skiving process, a

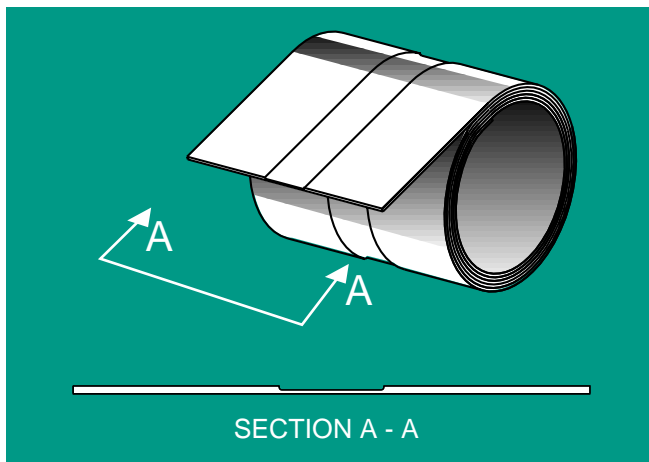

Coil of Material with Skived Section

blade cuts a channel in the center of the zinc strip. Littelfuse's innovative skiving equipment produces extremely precise channels in the zinc, depending on the requirements for that particular fuse style and amperage rating. The fuse element is then stamped from the skived section.

It is important to understand that although the process of skiving is a change to the geometry of the fuse, the Littelfuse skiving operation is not based on a set measurement for each current rating of each style of fuse. The variations in the zinc alloy are such that one single measurement cannot be applied to all fuse elements. In fact, the purpose of skiving is to factor out the variation in resistivity, so each zinc coil that enters Littelfuse's manufacturing process is skived independently to meet the resistance value needed for that particular fuse style and amperage rating.

Simply put: we don't skive to a size; we skive to a resistance. This process involves extensive testing of each new coil of zinc material to determine the resistivity, and testing of the skived material to ensure that it meets the required resistance.

Why isn't this process used in the initial shaping of the zinc raw material? It simply is not cost-effective and therefore would cause Littelfuse products to be more costly. The skiving operation targets the part of the raw material that will later be the center of the fuse element, and by doing this, creates a much more cost-effective method to produce higher tolerance within the material.

## The Skiving Advantage

Skiving allows Littelfuse to produce a reliable, one-piece component with little characteristic variation. Littelfuse's high-performance manufacturing technology allows the skived section to be cut so precisely, it can accurately affect the resistance of the fuse. The Littelfuse skiving operation can control the thickness so accurately that it reduces the spread of resistance to approximately 10% of the original unskived zinc coil.

This accuracy eliminates the variation of thickness for the material, and also counterbalances the resistivity variation within the material. The result is that all Littelfuse fuses with the same amperage rating have a very small spread of resistance, ensuring that each fuse is a calibrated device. Due to skiving, the rating of a Littelfuse fuse guarantees that the device will open at specific overloads at specific times.



World Headquarters: Littelfuse, Inc. • 800 E. Northwest Highway • Des Plaines, IL 60016  
1-847-824-1188 • FAX 1-847-803-5364

Visit the Littelfuse website at [www.littelfuse.com](http://www.littelfuse.com)