



WHITE  
PAPER



Expertise Applied | Answers Delivered

# NGR

**Why Neutral-Grounding Resistors  
Need Continuous Monitoring**

A resistance-grounded power system has a critical element that is often ignored—the neutral-grounding resistor. A resistance-grounded power system should have its neutral-grounding resistor continuously monitored. During a single-phase-to-ground fault, current flows from the transformer or generator winding through the faulted-phase conductor to the fault and to ground, returning to the source winding through the ground-return path and the neutral-grounding resistor.

When a neutral-grounding resistor fails, the failure mode is usually open circuit leaving the ground-return path open. Current-sensing ground-fault protection, which is the type most commonly employed in a resistance-grounded system, will not operate with an open resistor, and the advantages of resistance grounding are unknowingly lost. Inadvertent operation with an ungrounded system and inoperative ground-fault protection can be avoided by using a continuous neutral-grounding-resistor monitor.

This paper reviews the benefits of resistance grounding, compares continuous resistor monitoring with planned-maintenance testing and inspection, and defines the characteristics required of a neutral-grounding-resistor monitor. Case studies are presented that show the need for continuous monitoring of the neutral-grounding resistor.

## I. INTRODUCTION

Resistance grounding has been used in three-phase industrial applications for many years. Properly designed resistance grounding eliminates many of the problems associated with solidly and ungrounded systems while retaining their benefits. However, resistance grounding has a critical element that is often ignored—the neutral-grounding resistor (NGR).

Properly applied resistance grounding can limit point-of-fault damage, eliminate transient overvoltages, reduce the risk of an arc flash, provide continuity of service with a ground fault, and provide adequate current for ground-fault detection and selective coordination.

Unfortunately, the advantages of resistance grounding are replaced by the disadvantages of an ungrounded system when an NGR fails. The consequence of inadvertently operating with an ungrounded system can be avoided with the addition of continuous NGR monitoring.

In mining, the NGR is recognized as an integral part of the ground-return path and NGR failures occur regularly enough that the Canadian Standards Association mandates NGR monitoring [1].

A well-designed neutral-grounding-resistor monitor confirms the electrical path from the transformer or generator neutral through the NGR to the station ground. When powered from a separate source, the monitor will be active whether or not the system is energized and ensures a trip or alarm if an NGR failure occurs.

At the writing of this paper, there is no commercially available solution that provides continuous NGR monitoring for an NGR isolated from the system neutral by a single-phase transformer. The term “*resistance grounding*” is used here to refer to a resistor which is connected directly between the transformer or generator neutral and the system ground.

## II. NGR FAILURE MODE

The failure mode of an NGR is usually open circuit. A typical NGR element (shown in *Figure 1*) is constructed of resistance wire or metal strips coiled and wrapped around porcelain insulators. These assemblies are grouped as necessary for the application. Failure in short circuit is very unlikely—it is analogous to an incandescent light bulb failing in short circuit.



FIGURE 1

An NGR can be short-circuited accidentally during construction or maintenance. Unlike an open-circuited NGR a short-circuited NGR results in a grounded and stable electrical system. Ground-fault current will flow during a ground fault and the fault will be cleared by ground-fault or overcurrent protection.

### III. CAUSES AND FREQUENCY OF NGR FAILURE

An NGR is a mechanical component and is subject to mechanical failures. Although NGRs have no moving parts there are several other factors that affect the integrity of an NGR. A review of NGR manufacturers' data reveals that NGRs fail due to lightning, storms, earthquakes, overloads, or extended service life [2]. Other failure causes are corrosive atmospheres, extreme temperature changes, triplen harmonic currents, hail, manufacturing defects, and vibration. *Figure 2* shows an NGR thermal failure.



FIGURE 2

Every device has a useful service life and NGRs are no different. *Figure 3* shows an NGR in an outdoor location and housed in a steel mesh enclosure. Outdoor-installed equipment is subject to the local extremes of temperature and humidity. In an installation such as this, the resistor elements, insulators, terminals, welded joints, and wiring are exposed to falling and wind-driven rain, snow and hail.

A previously unknown NGR failure cause was reported by Lobos, Mannarino, Drobnjak, Ihara, and Skliutas [3]. The authors reported several NGR failures on a 26-kV utility substation. The probable cause for the failures is high-frequency (125 kHz) oscillation involving the inherent inductance of the NGR and system capacitance, with the oscillation of the system being triggered by transients produced by line-to-ground faults on 26-kV feeder circuits. The overvoltages were found to be two to four times the system voltage.

While writing this paper, one of the authors conducted a study of the NGRs at their facility. The 60-year old chemical plant has 80 substations of various ages. Ten are high-resistance grounded. Two open NGRs were discovered yielding a 20% failure rate. Table 1 summarizes this information.



FIGURE 3

- **80 substations**
  - **10 high-resistance grounded**
    - **2 open NGRs**
    - **20% failure rate**

TABLE 1

*Figures 4 and 5* show the failed NGRs. In *Figure 4* a broken spot weld resulted in an open NGR. In *Figure 5* a broken resistor element wire resulted in an open NGR.



FIGURE 4



FIGURE 5

## IV. CONSEQUENCES OF NGR FAILURE

Failure of the NGR converts a resistance-grounded system into an ungrounded system. Without continuous NGR monitoring there is no indication that the system has become ungrounded. Operators would not be aware that current-sensing ground-fault protection is no longer operational and that the risk of transient overvoltages exists.

Another potential hazard is that a phase-to-ground voltage test on an ungrounded system may not indicate the presence of voltage on an energized conductor. An electrician could then believe that energized phase conductors were safe to touch [4].

## V. NGR FAILURE DETECTION METHODS

An open-circuited NGR may not show external signs of failure. In cases where continuous monitoring is not employed, the system usually continues to operate until the open resistor is discovered following an event.

Occasionally, open resistors are discovered during preventative maintenance. In cases where the maintenance plan involves measurement of the NGR resistance, an open NGR would likely be discovered. However, there are no guarantees. There is an example from a maintenance company of an NGR with a weld that had broken. The NGR remained closed until a ground fault occurred.  $I^2R$  heating of the edge-wound NGR coils caused them to expand which then forced the broken weld to open. This illustrates the need for an NGR monitor to detect an NGR failure on a system where ground faults are indicated only by an alarm. Measurement of NGR resistance during maintenance only provides confirmation that the NGR was good at the time when the resistance was measured. The NGR could fail at any time after the measurement is taken, or in some cases not even be reconnected after the measurement.

Where maintenance involves testing ground-fault relays by using an intentional ground fault, an open NGR would likely be discovered as the result of an investigation into why ground-fault relays failed to operate.

When ground-fault relays are tested by primary current injection, as shown in *Figure 6*, false confirmation of ground-fault relay operation can occur. The ground-fault relays will respond to the injected current and appear to operate as designed despite the presence of an open NGR. This maintenance procedure would then have falsely confirmed the operation of ground-fault protection.

Planned maintenance is not the ideal means of determining NGR health. An open NGR is not a condition that should be allowed to remain on the system for any length of time. Further, there have been cases where NGRs disconnected for testing were not re-connected. In an example from a large industrial facility, eight NGRs were disconnected for transformer testing. Fortunately, shortly before the system was to be re-energized it was discovered that five of the NGRs had not been reconnected.

Examination of NGR preventative maintenance suggests that an automatic monitoring device is a better solution.

A continuous NGR monitor, as shown in *Figure 11* and *12*, detects an open NGR when the failure occurs. A continuous NGR monitor is active when control power is applied and indicates NGR health whether or not the system is energized, with or without a ground fault.

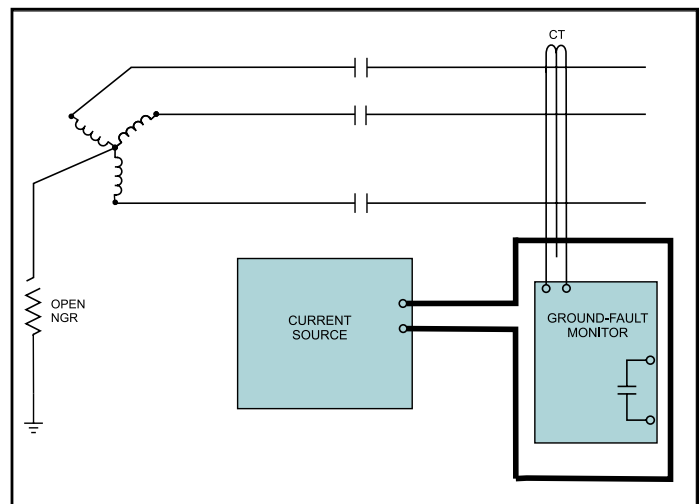

FIGURE 6

## VI. CONTINUOUS MONITORING REQUIREMENTS

The requirements of a continuous NGR monitor are [5]:

- The monitor must be capable of detecting an NGR failure whether or not there is a ground-fault on the system.
- The monitor must work in tripping or alarm-only systems.
- The monitor must not be exposed to neutral voltage during a ground fault.
- Monitoring the NGR should include monitoring the neutral and ground connections.
- The monitor should not be capacitively or inductively coupled to the NGR as this could contribute to ferroresonance if the resistor fails.
- If ground-fault protection is included, the monitor should be capable of detecting a ground fault when the NGR is open.

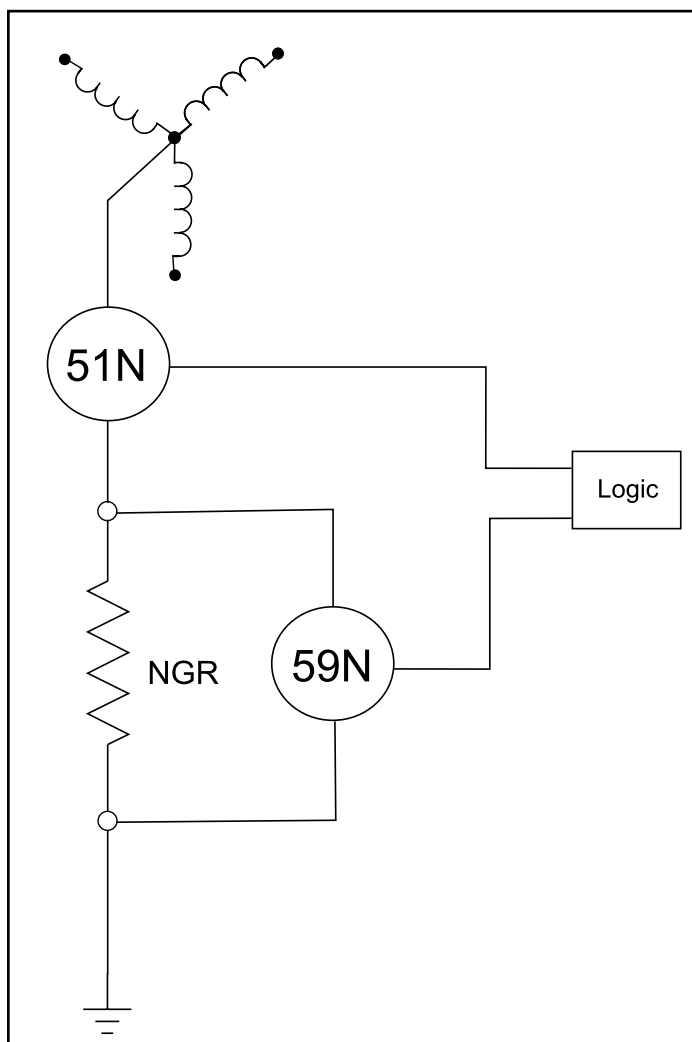

FIGURE 7

A potential transformer and a time-delay voltage relay connected across an NGR is not continuous NGR monitoring. This is a voltage-based ground-fault detector and it does not monitor NGR continuity. Rather, it monitors neutral voltage and it will not operate until a ground fault occurs, regardless of the condition of the NGR.

A similar approach is to apply an overvoltage measurement (59N), an overcurrent measurement (51N), and a logic circuit to the NGR as shown in *Figure 7*. The combination of these devices can detect an NGR failure only if there is a ground fault on the system. If the voltage measurement indicates the presence of voltage and the current measurement indicates the presence of current then there is a ground fault on the system. Since there is current flowing through the NGR it must be continuous. If the voltage measurement indicates the presence of voltage but the measured current in the NGR is zero, then the NGR must be open. This design is not considered continuous NGR monitoring because it relies on the presence of a ground fault to operate.

This method has been tested in industry. A device similar to that shown in *Figure 7* was applied on a 69-kV system in a Canadian mining operation. With no ground fault on the system, the device was unable to determine NGR continuity.

Another possibility involves the use of a resistance measurement, similar to an ohmmeter, and an output contact as an NGR monitor (shown in *Figure 8*). Problems with the resistance measurement method include the

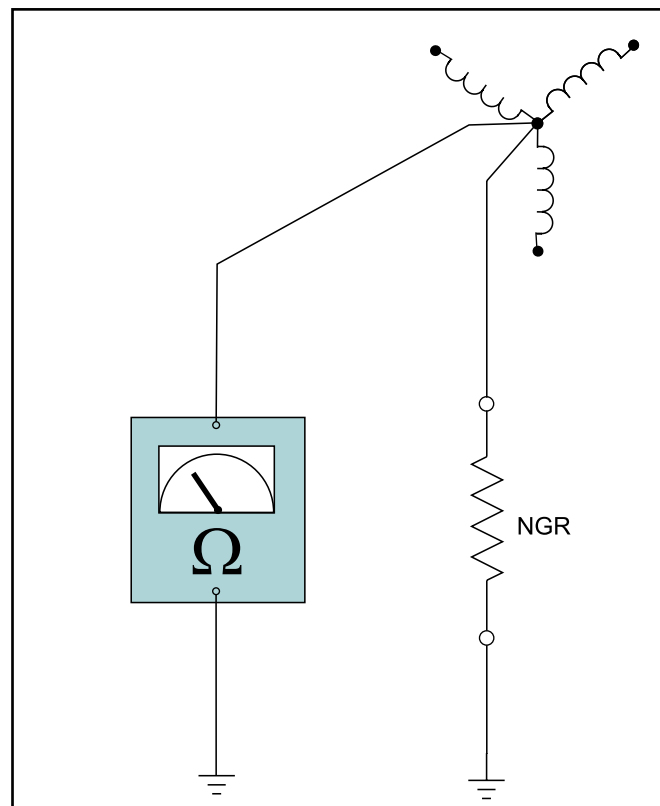

FIGURE 8

possibility for interference by external DC influences, as shown in *Figure 9*, and the possibility that continuity through a ground fault may be recognized as NGR continuity, as shown in *Figure 10*.

The resistance measurement can be influenced by DC currents in the measuring circuit. There are many possible sources of stray DC voltage in industrial electrical systems. DC can be impressed on the system by sources such as a ground fault on the DC bus of an adjustable speed drive and more obscure sources such as atmospheric electrical conditions. *Figure 9* shows a charged cloud that impresses a DC voltage on the system. Under the right conditions, this charged cloud can interfere with the resistance measurement to a degree which would cause it to fail to operate as designed.

Another problem with the resistance measurement method is the possibility of measuring continuity through a ground fault. When a ground fault occurs there are two parallel paths presented to the resistance measuring device. There is one path through the NGR, and another path through the transformer or generator winding of the faulted phase to, the fault, and back to the measuring device through ground.

If the NGR fails during a ground fault, the resistance-measuring device could measure a resistance similar to the NGR through the ground fault. *Figure 10* shows how a resistance monitoring device could be satisfied by measuring resistance through a ground fault. Under these circumstances a resistance measurement would falsely indicate that the NGR was continuous.

A better solution is the combination of an overvoltage measurement (59N), an overcurrent measurement (51N), and a resistance measurement as shown in *Figure 11*. This solution is better because it continuously monitors NGR continuity.

A continuous NGR monitor combines measured NGR current, transformer or generator neutral voltage, and NGR resistance to continuously determine the health of the NGR. *Figure 12* shows a typical NGR monitor and the connections to the NGR.

The resistance measurement is the sum of the resistance from the sensing resistor, to the neutral point, through the NGR to ground, and through ground back to the monitor. Connecting the sensing resistor to a separate lug on the neutral bus assures that the NGR connection to the neutral point is part of the monitored loop.

When there is no ground fault on the system, a measurement of NGR resistance is enough to confirm NGR continuity. The monitor determines the presence of a ground fault through the voltage and current measurements. Voltage on the neutral and current in the NGR indicates a ground fault.

When a ground fault is present, a resistance measurement is not sufficient to confirm NGR continuity because of the possibility of measuring continuity through the fault as shown in *Figure 10*. Because a resistance measurement alone is not sufficient to confirm NGR continuity, the monitor constantly evaluates resistance, current, and voltage measurements.

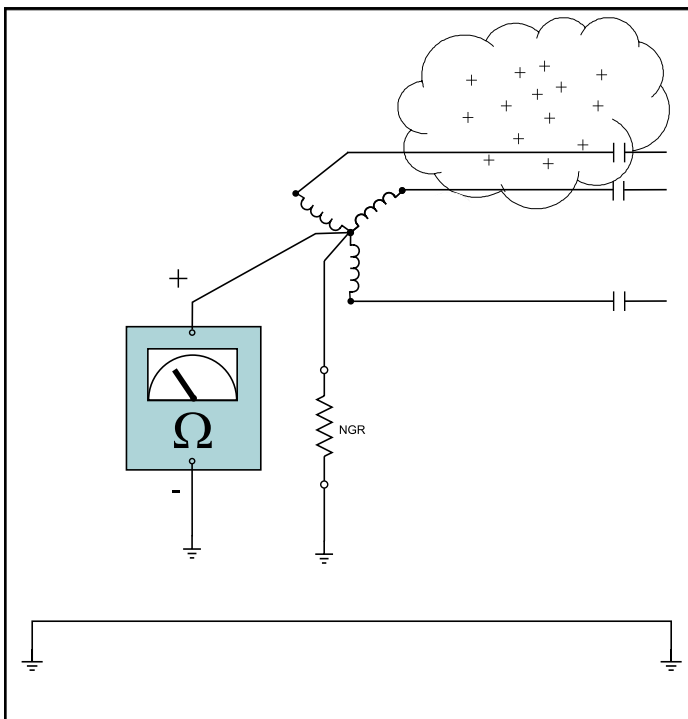

FIGURE 9

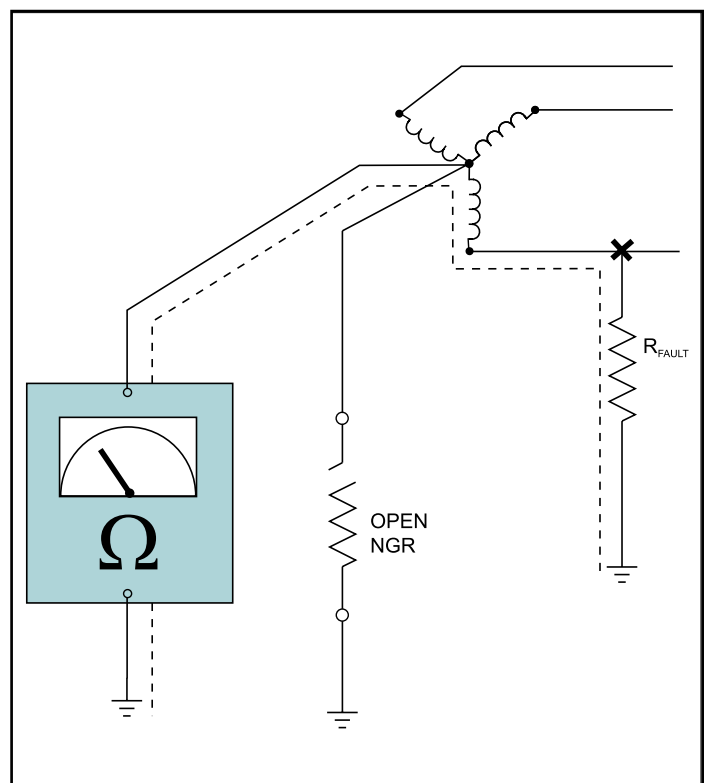

FIGURE 10

When neutral voltage is elevated and current is flowing through the NGR, the NGR must be continuous. When the neutral voltage is elevated but no current flows through the NGR the NGR must be open. The ability to detect an open NGR, in the presence of a ground fault is particularly important in alarm-only systems where ground faults can remain on the system for long periods.

When a ground fault occurs in a resistance-grounded system, voltage appears on the system neutral. In the case of a bolted fault, the transformer or generator neutral elevates to line-to-neutral voltage. An NGR monitor that is directly connected to the system neutral brings a conductor with line-to-neutral voltage during a ground fault into a low-voltage control cubicle. This is not acceptable in many applications. The sensing resistor, as shown in *Figure 12*, connects the monitor to the power system while isolating it from neutral voltage. The sensing resistor limits the voltage transfer from the system neutral to the NGR monitor. The resistive elements of the sensing resistor will not contribute

to ferroresonance. Ferroresonance is a condition in which magnetic saturation of an iron core working in conjunction with system capacitance results in voltage oscillations. These oscillations can produce overvoltages which may exceed two to three times system voltage [6]. A failure of the sensing resistor results in a resistor-fault trip since the resistance measurement reads an open circuit.

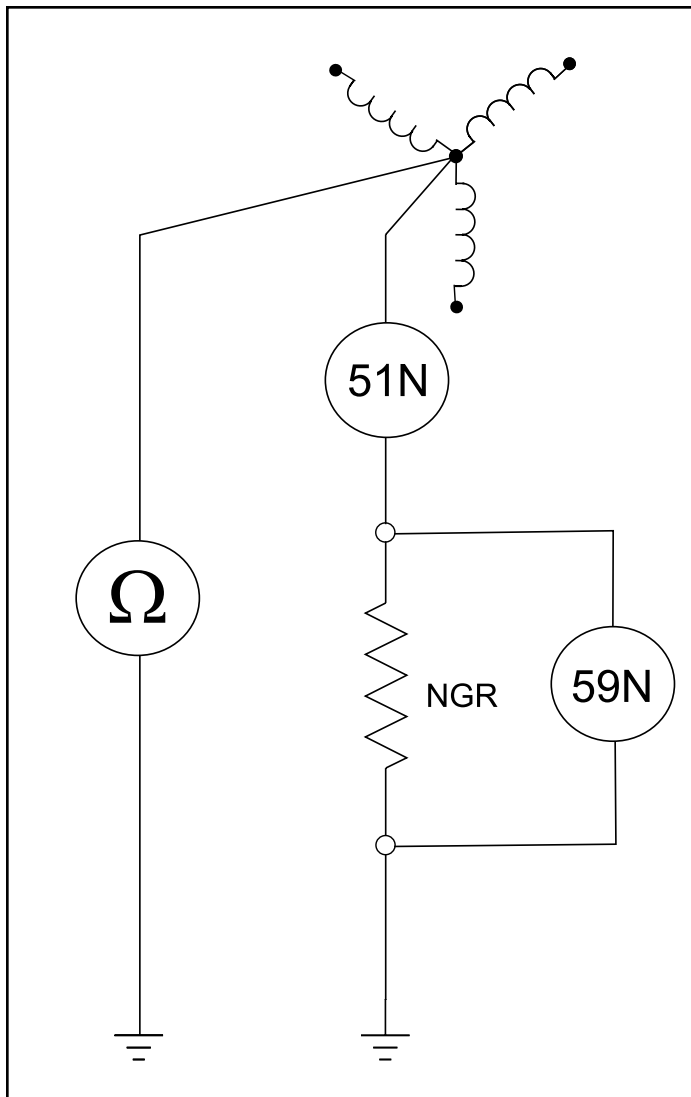

FIGURE 11

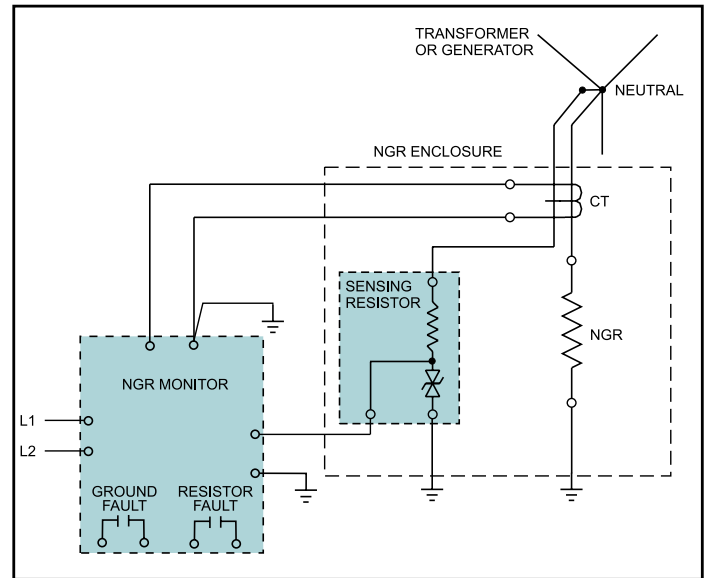

FIGURE 12

## VII. NGR FAILURE CASE STUDIES

### A. Mine Safety and Health Administration Fatality Report:

The following event occurred at an underground coal mine in Virginia on November 11, 1991. Several factors contributed to a fatality. The victim was not qualified to perform electrical work, the circuit was not locked and tagged out, a trailing-cable monitor was defeated, there was an existing ground-fault, and the NGR was open.

A loaded, cable-powered shuttle car was tramping away from a continuous mining machine when its cable-reel-motor drive chain came off the sprocket. The cable reel locked and the forward momentum of the tram pulled the portable power cable apart at a splice. The victim touched an exposed phase conductor with his bare hand several times and then grounded the exposed phase conductor against the mine rib in order to determine whether the cable was energized. The victim was then electrocuted when he contacted the energized conductor and the mine floor, by current flowing phase-to-phase through the existing ground fault, the ground, and then the victim [7].

There were several unsafe conditions that, had they been corrected, would have saved the victim; the primary of which is the failure to lock-out and tag-out the circuit breaker.

Had the mine employed continuous NGR monitoring, the

NGR-monitoring relay would have de-energized the circuit when the NGR opened.

## B. Soft Starter Failure:

A soft starter manufacturer reported that its soft starters operated in an unexpected manner when an NGR was open.

The soft starter responded to reference pulses from each of the three line-to-ground voltage signals. With the neutral properly grounded, all three voltage signals are balanced. Failure of the NGR allows the neutral voltage to float and the three voltage signals to become unbalanced. The unbalanced voltages were interpreted by the soft starter as a single phase condition which caused a trip.

Upon studying the situation the manufacturer concluded that the problem was due to unbalanced reference voltages. Through further study and customer interviews it was determined that an open NGR was responsible for the unbalanced reference voltages.

Had the customer employed continuous NGR monitoring the open NGR would have been discovered before it caused problems with the soft starter.

## C. Loose Connections on an NGR:

In Canadian mining operations, continuous NGR monitoring is required. The following incident occurred at a mine in Eastern Canada on a 200 A, 4160 V NGR.

The NGR monitoring relay tripped on a resistor fault. Upon inspection, electricians noticed a loose connection on the NGR. By moving the loose connection the electricians were able to reset the resistor fault on the monitor and then cause the monitor to trip on resistor fault again. The loose connection was tightened and the rest of the NGR connections were inspected. Eight other loose connections were found and repaired. The equipment was restarted and the resistor fault trip did not reoccur.

## VIII. CONCLUSION

The information presented here has shown that an open NGR is an undesirable situation. A system with an open NGR is subject to transient overvoltages and current-sensing ground-fault protection will not indicate the presence of a ground fault. A ground fault then remains on the system and might escalate to a phase-to-phase fault.

NGRs are subject to failures related to thermal overload, lightning, storms, earthquakes, wildlife, extended service life, manufacturing defects, vibration, corrosion, and improper specification or installation.

A well-designed NGR monitor provides continuous protection against failures that previously rendered ground-fault protection, coordination, and annunciation systems inoperative, as well as leaving the system exposed to damaging transient overvoltages. An NGR monitor provides confidence that current-sensing ground-fault protection will operate as designed on the next ground fault.

## IX. REFERENCES

- [1] CSA International, "M421-00 Use of Electricity in Mines", 2000
- [2] Post Glover, "Neutral Grounding Resistors Installation and Maintenance Instructions", PGR Document #NG111-06
- [3] W. Labos, A. Mannarino, G. Drobnjak, S. Ihara, and J. Skliutas, "A Possible Mechanism for Neutral Grounding Resistor Failures," *Power Engineering Society General Meeting*, Jun 2005
- [4] K.S Crawford and N. K. Haggerty, "Test Before Touch – Easier Said Than Done," *IEEE Petroleum and Chemical Industry Committee Conference*, Sept. 2006
- [5] G.E. Paulson, "Monitoring neutral-grounding resistors," *IEEE Pulp and Paper Industry Committee Conference*, June 1999
- [6] D. Beeman, "Industrial Power System Handbook – First Edition," 1955, Pages 281 – 284
- [7] L.T. Ward and G. Deel, "Accident Investigation Report (Underground Coal Mine)," *United States Department of Mine Safety and Health Administration*, Nov 1991

This article originally appeared in the IEEE Industry Applications Magazine September/October 2010 edition. © 2010 IEEE

By Donald Selkirk, Mervin Savostianik, & Kenneth Crawford. Mervin Savostianik (MSavostianik@Littelfuse.com) is with Littelfuse Startco in Saskatoon, Saskatchewan. Donald Selkirk was formerly with Littelfuse Startco in Saskatoon, Saskatchewan. Kenneth Crawford is with DuPont Company in Washington, West Virginia. Selkirk, Savostianik, and Crawford are Members of the IEEE. This article was first presented as "Why Neutral-Grounding Resistors Need Continuous Monitoring" at the 2008 IEEE Petroleum and Chemical Industry Technical Conference.

Additional technical information and application data for Littelfuse POWR-GARD® protection relays, fuses and other circuit protection and safety products can be found on [www.littelfuse.com](http://www.littelfuse.com). For questions, contact our Technical Support Group (800-832-3873). Definitions of terms used in this white paper can be found in the Technical Application Guide section of the POWR-GARD Catalog. To download a copy visit [www.littelfuse.com/catalogs](http://www.littelfuse.com/catalogs).