

## High Speed Transmission Equipment

High speed transmission equipment encompasses a broad range of transmission protocols such as T1/E1, xDSL, and ISDN. Transmission equipment is located at the central office, customer premises, and remote locations.

### Protection Requirements

Transmission equipment should be protected against overvoltages that can exceed 2500 V and surge currents up to 500 A. In Figure 3.7 through Figure 3.17, *SIDACtor* devices were chosen because their associated peak pulse current ( $I_{PP}$ ) rating is sufficient to withstand the lightning immunity tests of GR 1089 without the additional use of series line impedance. Likewise, the fuse shown in Figure 3.7 through Figure 3.17 was chosen because the  $\text{amps}^2\text{time}$  ( $I^2t$ ) rating is sufficient to withstand the lightning immunity tests of GR 1089, but low enough to pass GR 1089 current limiting protector test and power cross conditions (both first and second levels).

The following regulatory requirements apply:

- TIA-968 (formerly known as FCC Part 68)
- GR 1089-CORE
- ITU-T K.20/K.21
- UL 60950

Most transmission equipment sold in the US must adhere to GR 1089. For Europe and other regions, ITU-T K.20/K.21 is typically the recognized standard.

### ADSL Circuit Protection

Asymmetric Digital Subscriber Lines (ADSLs) employ transmission rates up to 6.144 Mbps from the Central Office Terminal (COT) to the Remote Terminal (RT) and up to 640 kbps from the RT to the COT at distances up to 12,000 feet. (Figure 3.7)

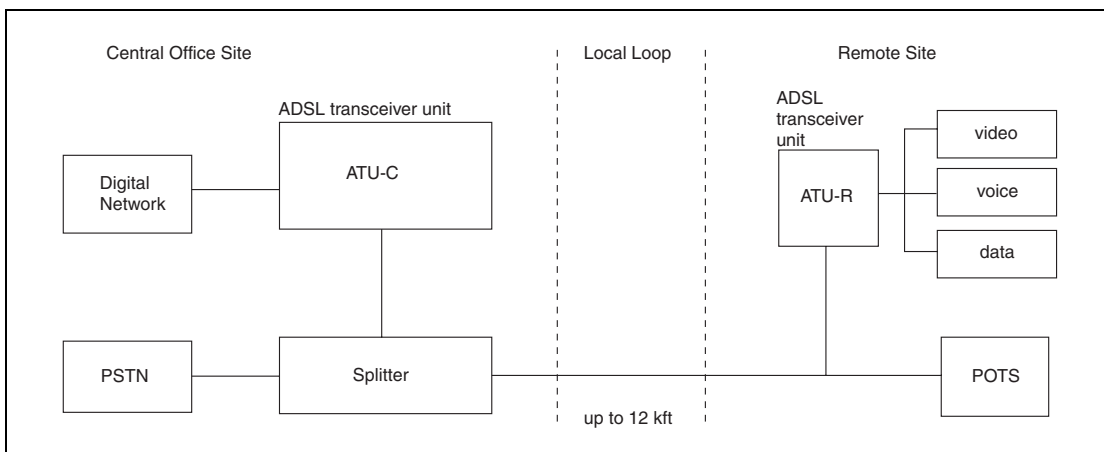

Figure 3.7 ADSL Overview

### Protection Circuitry

Longitudinal protection was not used at either the ADSL Transceiver Unit – Central Office (ATU-C) interface or the ADSL Transceiver Unit – Remote (ATU-R) interface due to the absence of earth ground connections. (Figure 3.8) In both instances, the P3500SC MC *SIDACtor* device and the **0461 1.25** *TeleLink* fuse provide metallic protection. For ATUs not isolated from earth ground, reference the HDSL protection topology.

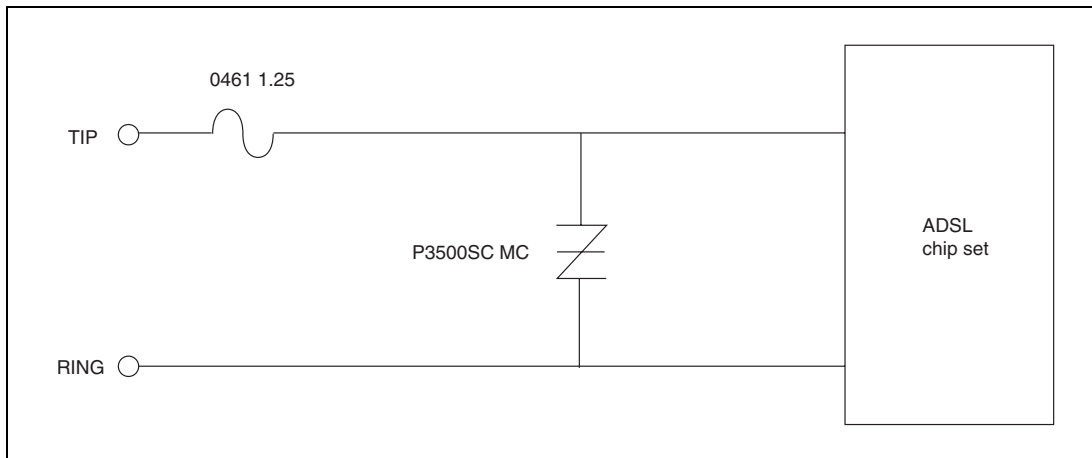

Figure 3.8 ADSL Protection

### Component Selection

The P3500SC MC *SIDACtor* device and **0461 1.25** *TeleLink* fuse were chosen to protect the ATUs because both components meet GR 1089 surge immunity requirements without the use of additional series resistance. Although the P3100 series *SIDACtor* device may be used to meet current ANSI specifications, Teccor recommends the P3500 series to avoid interference with the  $20 V_{P-P} \times DSL$  signal on a 150 V rms ringing signal superimposed on a 56.5 V battery.

### HDSL Circuit Protection

HDSL (High-bit Digital Subscriber Line) is a digital line technology that uses a 1.544 Mbps (T1 equivalent) transmission rate for distances up to 12,000 feet, eliminating the need for repeaters. The signaling levels are a maximum of  $\pm 2.5$  V while loop powering is typically under 190 V. (Figure 3.9)

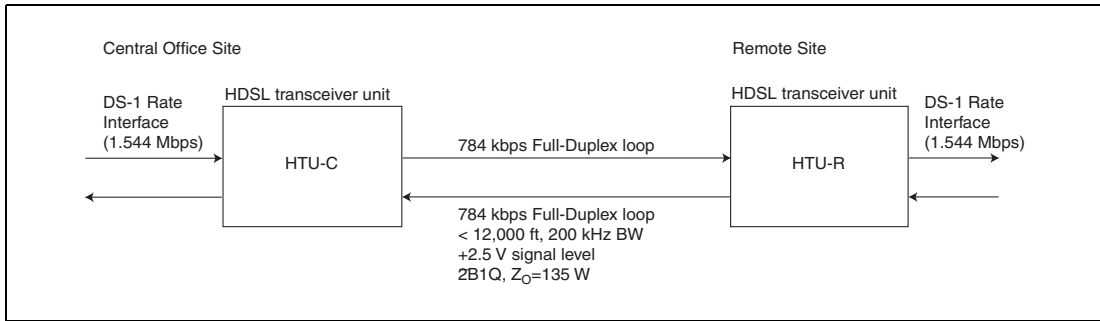

Figure 3.9 HDSL Overview

Protection Circuitry

Longitudinal protection is required at both the HDSL Transceiver Unit – Central Office (HTU-C) and HDSL Transceiver Unit – Remote (HTU-R) interfaces because of the ground connection used with loop powering. Two P2300SC MC SIDACtor devices provide overvoltage protection and two 0461 1.25 TeleLink fuses (one on Tip, one on Ring) provide overcurrent protection. (Figure 3.10) For the transceiver side of the coupling transformer, additional overvoltage protection is provided by the P0080SA SIDACtor device. The longitudinal protection on the primary coil of the transformer is an additional design consideration for prevention of EMI coupling and ground loop issues.

Reference Designs

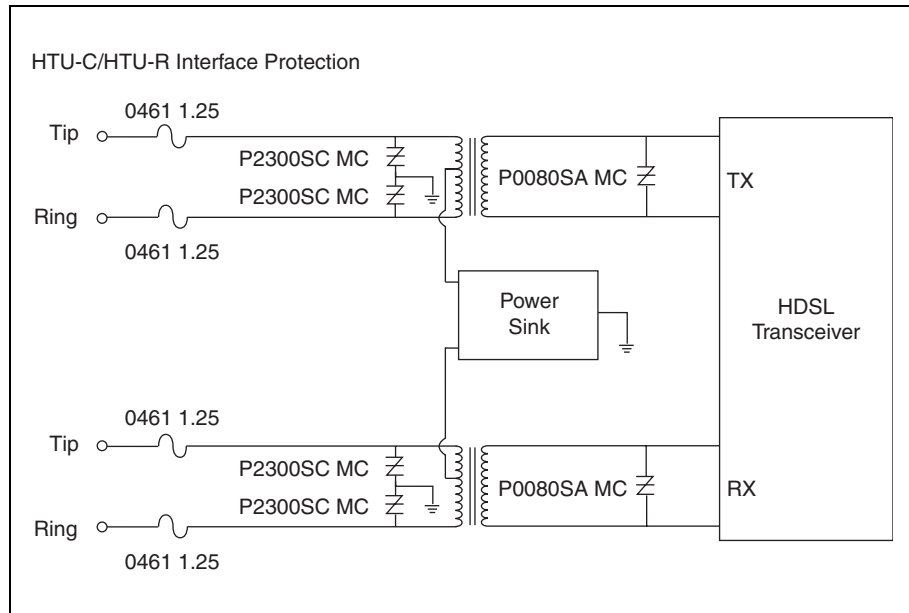

Figure 3.10 HDSL Protection

### Component Selection

The P2300SC MC *SIDACtor* device and the **0461** 1.25 *TeleLink* fuse were chosen because both components meet GR 1089 surge immunity requirements without the use of additional series resistance. The P2300SC MC voltage rating was selected to ensure loop powering up to 190 V. For loop powering greater than 190 V, consider the P2600SC MC. The P0080SA MC *SIDACtor* device was chosen to eliminate any sneak voltages that may appear below the voltage rating of the P2300SC MC.

### ISDN Circuit Protection

Integrated Services Digital Network (ISDN) circuits require protection at the Network Termination Layer 1 (NT1) U-interface and at the Terminating Equipment (TE) or Terminating Adapter (TA) S/T interface. Signal levels at the U-interface are typically  $\pm 2.5$  V; however, with sealing currents and maintenance loop test (MLT) procedures, voltages approaching 150 V rms can occur. (Figure 3.11)

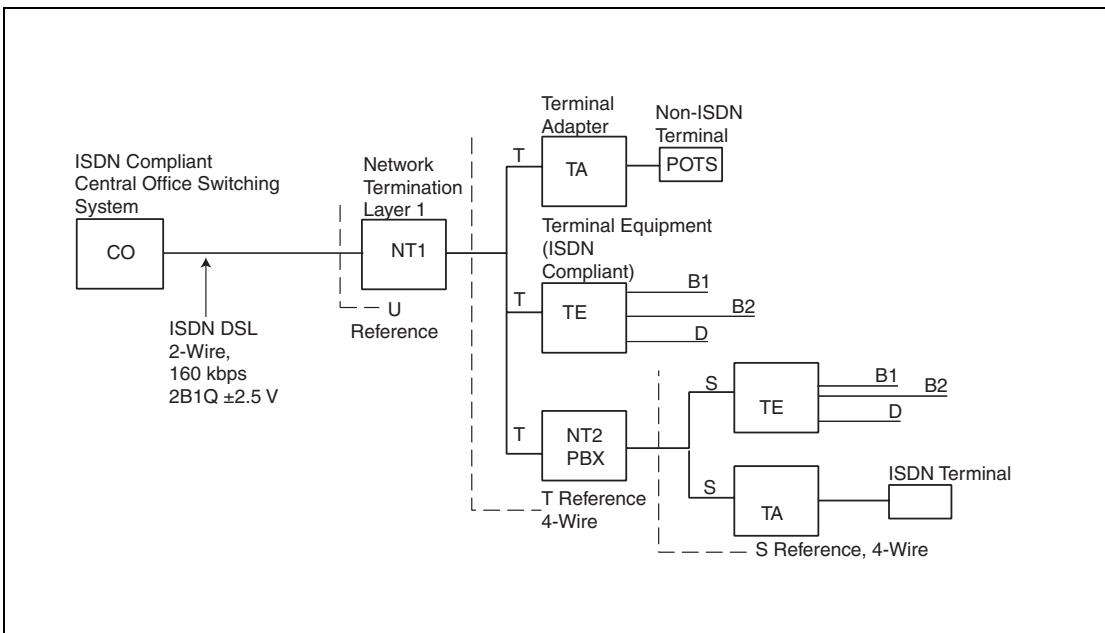

Figure 3.11 ISDN Overview

### Protection Circuitry

Longitudinal protection was not used at either the U- or the TA/TE-interface due to the absence of an earth-to-ground connection. (Figure 3.12) At the U-interface, the P2600SC MC *SIDACtor* device and **0461** 1.25 *TeleLink* fuse provide metallic protection, while the TA/TE-interface uses the P0640SC MC *SIDACtor* device and **0461** 1.25 *TeleLink* fuse. Figure 3.12 also shows interfaces not isolated from earth ground.

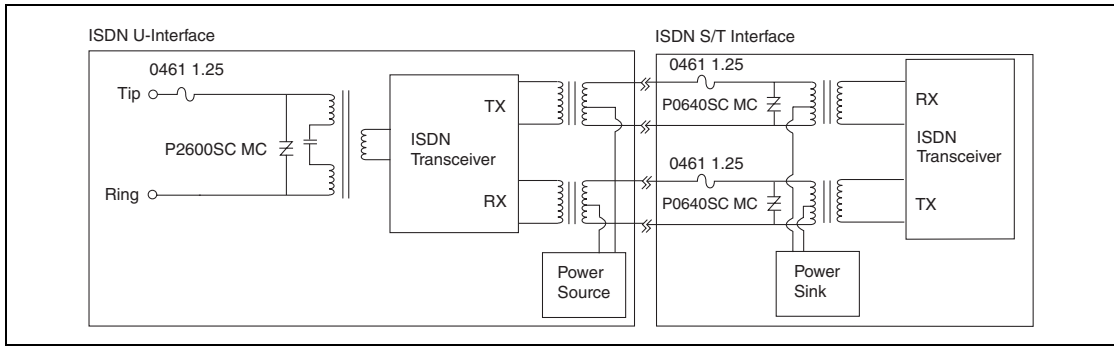

Figure 3.12 ISDN Protection

### Component Selection

The “SC MC” *SIDAct*or devices and **0461 1.25 TeleLink** fuse were chosen because these components meet GR 1089 surge immunity requirements without the use of additional series resistance. An MC is chosen to reduce degradation of data rates. The P2600SC MC voltage rating was selected to ensure coordination with MLT voltages that can approach 150 V rms. The voltage rating of the P0640SC MC was selected to ensure coordination with varying signal voltages.

### Pair Gain Circuit Protection

A digital pair gain system differs from an ISDN circuit in that ring detection, ring trip, ring forward, and off-hook detection are carried within the 64 kbps bit stream for each channel rather than using a separate D channel. The pair gain system also uses loop powering from 10 V up to 145 V with a typical maximum current of 75 mA. (Figure 3.13)

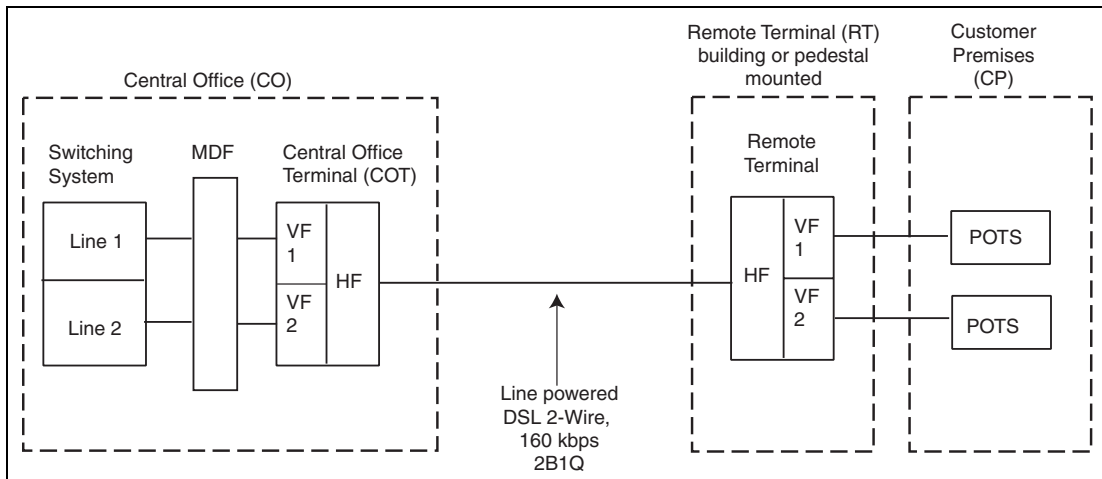

Figure 3.13 Pair Gain Overview

*Protection Circuitry*

Longitudinal protection is required at the Central Office Terminal (COT) interface because of the ground connection used with loop powering. (Figure 3.14) Two P1800SC MC *SIDACtor* devices provide overvoltage protection and two **0461** 1.25 *TeleLink* fuses (one on Tip, one on Ring) provide overcurrent protection. For the U-interface side of the coupling transformer, the illustration shows the P0080SA MC *SIDACtor* device used for additional overvoltage protection.

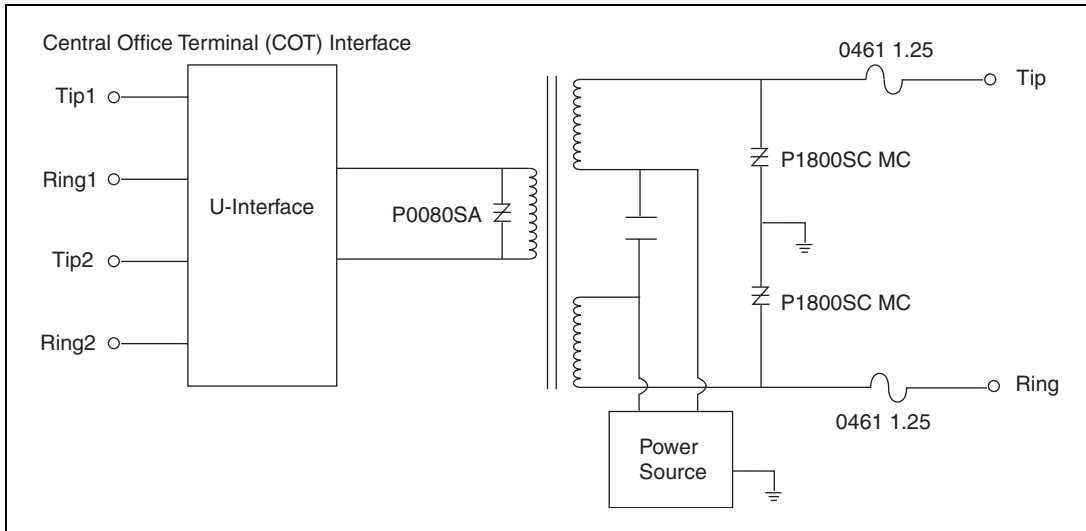

Figure 3.14 Pair Gain COT Protection

For Customer Premises (CP) and Remote Terminal (RT) interfaces where an earth ground connection is not used, only metallic protection is required. Figure 3.15 shows metallic protection satisfied using a single P3100SC MC across Tip and Ring and a single **0461** 1.25 on either Tip or Ring to satisfy metallic protection.

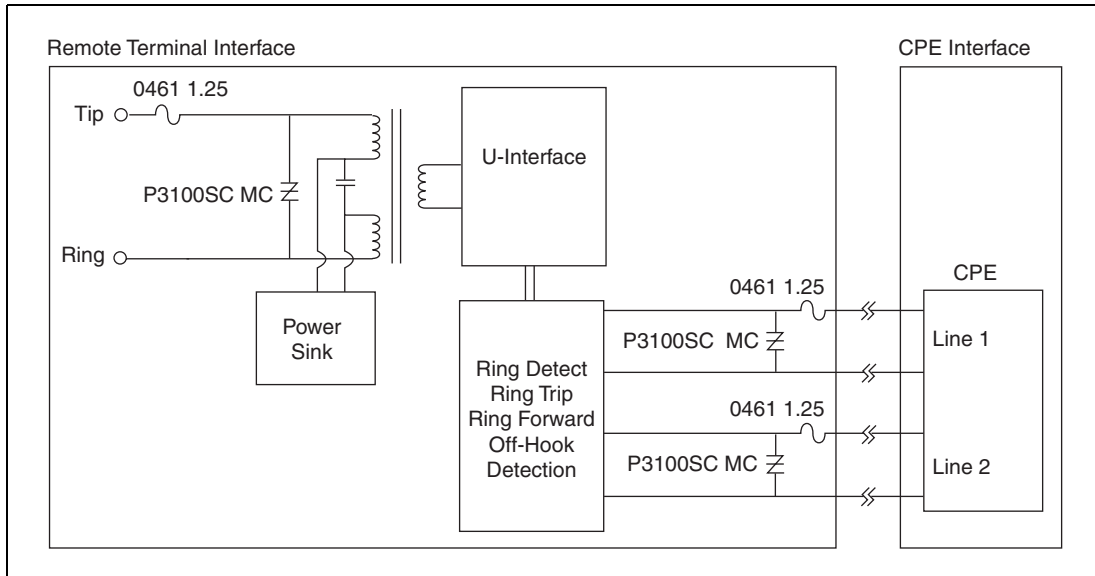

Figure 3.15 Pair Gain RT Protection

### Component Selection

The "SC MC" SIDACtor device and 0461 1.25 TeleLink fuse were chosen because both components meet GR 1089 surge immunity requirements without the use of additional series resistance. An MC is chosen to reduce degradation of data rates. The voltage rating of the P1800SC MC was selected to ensure coordination with loop powering up to 150 V. The voltage rating of the P3100SC MC was selected to ensure coordination with POTS ringing and battery voltages.

### T1/E1/J1 Circuit Protection

T1/E1 networks offer data rates up to 1.544 Mbps (2.058 for E1) on four-wire systems. Signal levels on the transmit (TX) pair are typically between 2.4 V and 3.6 V while the receive (RX) pair could go as high as 12 V. Loop powering is typically  $\pm 130$  V at 60 mA, although some systems can go as high as 150 V. (Figure 3.16)

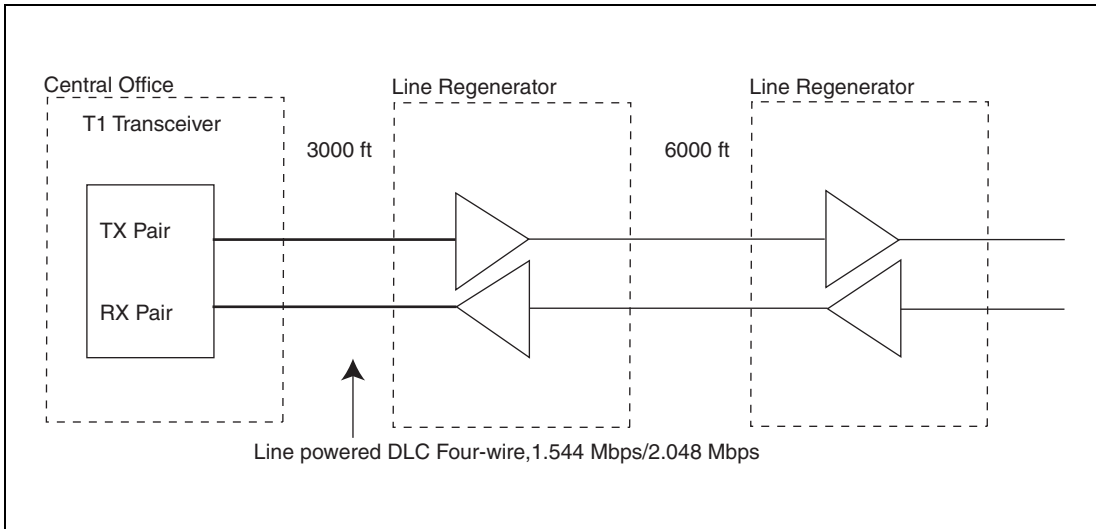

Figure 3.16 T1/E1 Overview

### Protection Circuitry

Longitudinal protection is required at the Central Office Terminal (COT) interface because of the ground connection used with loop powering. (Figure 3.17) Two P1800SC MC *SIDACtor* devices provide overvoltage protection and two **0461** 1.25 *TeleLink* fuses (one on Tip, one on Ring) provide overcurrent protection. The P1800SC MC device is chosen because its  $V_{DRM}$  is compliant with TIA-968 regulations, Section 4.4.5.2, "Connections with protection paths to ground." These regulations state:

Approved terminal equipment and protective circuitry having an intentional dc conducting path to earth ground for protection purposes at the leakage current test voltage that was removed during the leakage current test of section 4.3 shall, upon its replacement, have a 50 Hz or 60 Hz voltage source applied between the following points:

- a. Simplex telephone connections, including Tip and Ring, Tip-1 and Ring-1, E&M leads and auxiliary leads
- b. Earth grounding connections

The voltage shall be gradually increased from zero to 120 V rms for approved terminal equipment, or 300 V rms for protective circuitry, then maintained for one minute. The current between (a) and (b) shall not

exceed 10 mA<sub>PK</sub> at any time. As an alternative to carrying out this test on the complete equipment or device, the test may be carried out separately on components, subassemblies, and simulated circuits, outside the unit, provided that the test results would be representative of the results of testing the complete unit.

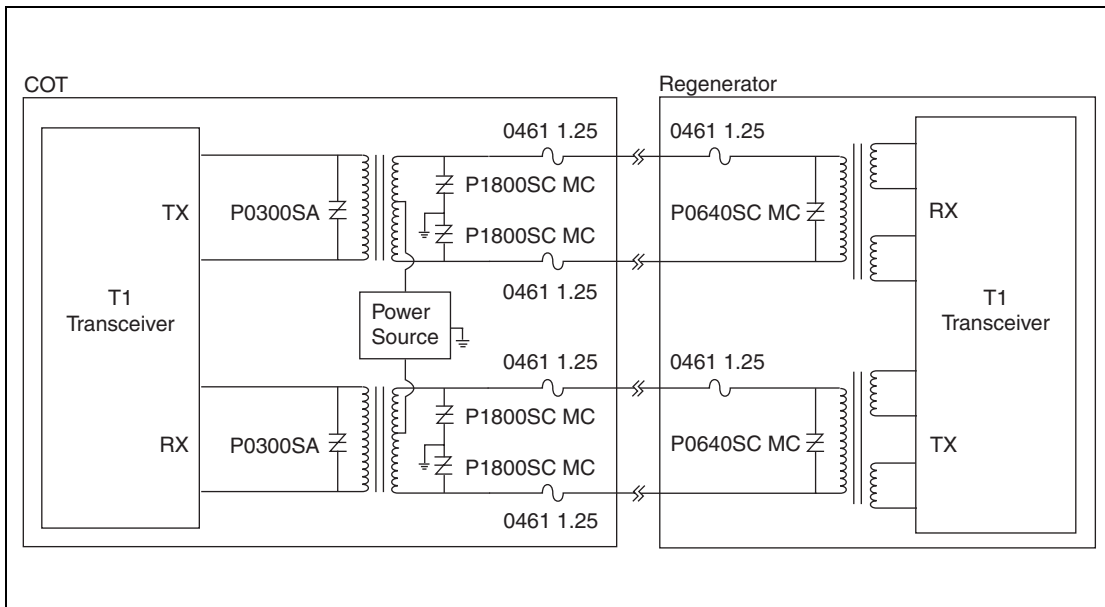

Figure 3.17 T1/E1 Protection

The peak voltage for 120 V rms is 169.7 V. The minimum stand-off voltage for the P1800 is 170 V, therefore, the P1800SC MC will pass the test in Section 4.4.5.2 by not allowing 10 mA of current to flow during the application of this test voltage.

For the transceiver side of the coupling transformer, additional overvoltage protection is shown in Figure 3.17 using the P0300SA SIDACtor device. When an earth ground connection is not used, only metallic protection is required. Metallic protection is satisfied using a single P0640SC MC SIDACtor device across Tip and Ring and a single 0461 1.25 TeleLink fuse on either Tip or Ring.

#### Component Selection

The "SC MC" SIDACtor device and 0461 1.25 TeleLink fuse were chosen because these components meet GR 1089 surge immunity requirements without the use of additional series resistance. An MC is chosen to reduce degradation of data rates. The voltage rating of the P1800SC MC was selected to ensure loop powering up to 150 V. The voltage rating of the P0640SC MC was selected to ensure coordination with varying voltage signals.

Reference Designs

### T1/E1/J1 Asymmetrical Circuit Protection

The A2106UC6 Surface Mount *SIDACtor* device provides asymmetrical protection for T1/E1/J1 transceivers. Metallic events are limited to less than 80 V on the line side of the transformer. The minimum turn on voltage for the A2106 is 170 V from tip to ground and ring to ground. This is compliant with TIA-968 (formerly known as FCC Part 68). The secondary side of the transformer has the P0080SA MC *SIDACtor* device that limits differential voltages to less than 25 V.

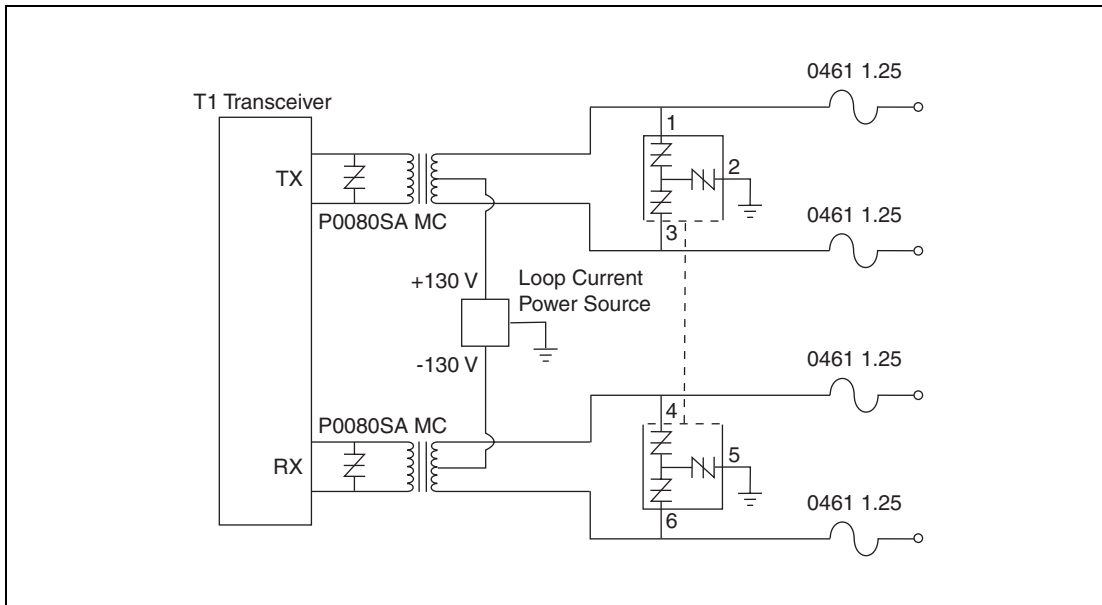

Figure 3.18 T1/E1/J1 Protection

#### Protection Circuitry

The T1/E1 transceiver circuit is protected from AC power cross events (also known as over current events) by the **0461 1.25 TeleLink** fuses. The *TeleLink* fuses in combination with the *SIDACtor* devices are compliant with the requirements of GR 1089, TIA-968, and UL 60950.

### Additional T1 Design Considerations

A T1 application can be TIA-968 approved as two different possible device types. An XD device means an external CSU is used and the unit does not have to meet the TIA-968 environmental test conditions, but it must connect only behind a separately registered DE device. This XD equipment does not have to meet the T1 pulse template requirements. If not classified as an XD device, then typically the application must adhere to TIA-968 environmental test conditions.

### T3 Protection

The capacitance across the pair of wires = (D1 || D2) + P0640EC/SC. The diode capacitance is approximately (10 pF || 10 pF) 20 pF. Then adding the capacitive effect of the P0640EC/SCMC, which is typically 60 pF, the total capacitance across the pair of wires is approximately 15 pF. The MUR 1100E diodes are fast-switching diodes that will exhibit this level of capacitance. MURS160T3 is a surface mount equivalent. (Figure 3.19)

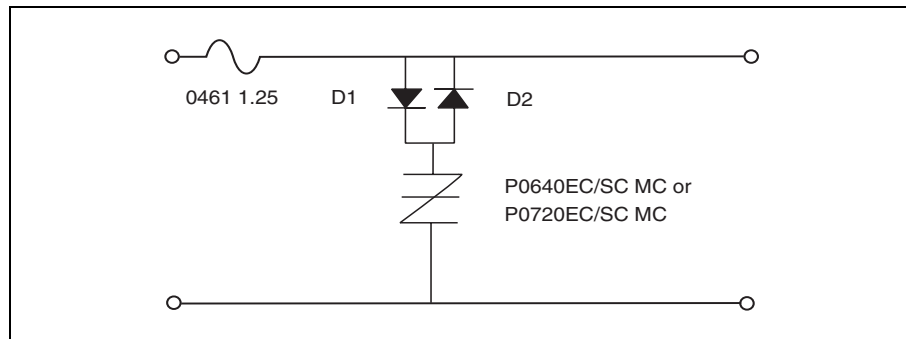

Figure 3.19 T3 Protection

Alternately, the advanced P0642SA exhibits very low capacitance and can be used as a stand-alone device.

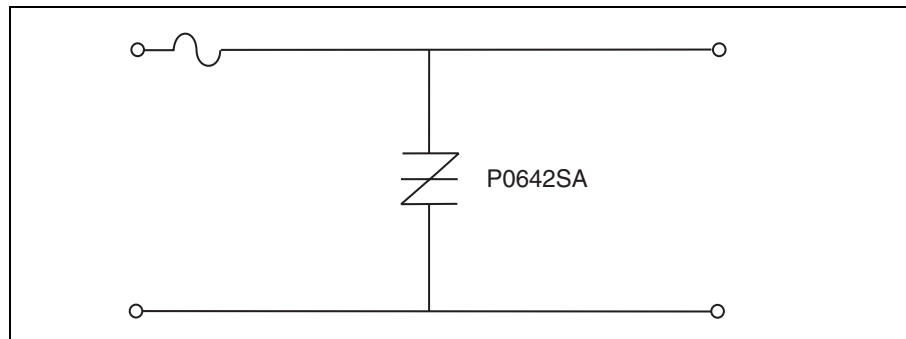

Figure 3.20 Alternate T3 Protection

Reference Designs