

Primary Protection

Primary telecommunications protectors must be deployed at points where exposed twisted pairs enter an office building or residence. This requirement is mandated in North America by the National Electric Code (NEC) to protect end users from the hazards associated with lightning and power cross conditions.

Primary protection is provided by the local exchange carrier and can be segregated into three distinct categories:

- Station protection — typically associated with a single twisted pair
- Building entrance protection — typically associated with multiple (25 or more) twisted pair
- Central office protection — typically associated with numerous twisted pair feeding into a switch

Station protectors provide primary protection for a single-dwelling residence or office. The station protector is located at the Network Interface Unit (NIU), which acts as the point of demarcation, separating the operating company's lines from the customer's.

Building entrance protection is accomplished by installing a multi-line distribution panel with integrated overvoltage protection. These panels are normally located where multiple twisted pairs enter a building.

A five-pin protection module plugged into a Main Distribution Frame (MDF) provides Central and Remote Office protection. Like station and building entrance protection, the MDF is located where exposed cables enter the switching office.

Teccor also offers a full line of five-pin protectors. For further details, contact factory at protectionsystems@teccor.com or +1 972-580-7777.

Protection Requirements

Station protectors must be able to withstand 300 A 10x1000 surge events. The building entrance protectors and CO protectors must be able to withstand 100 A 10x1000 surge events. Figure 3.51 shows building entrance protector and CO protector asymmetrical solutions. Figure 3.52 shows building entrance protector and CO protector balanced solutions.

The following regulatory requirements apply:

- UL 497
- GR 974-CORE
- ITU K.28

Primary Protection Reference Circuit

Figure 3.51 and Figure 3.52 show different configurations used in primary protection. Note that the peak off-state voltage (V_{DRM}) of any device intended for use in primary protection applications should be greater than the potential of a Type B ringer superimposed on a POTS (plain old telephone service) battery.

$$150 V_{RMS} \sqrt{2} + 56.6 V_{PK} = 268.8 V_{PK}$$

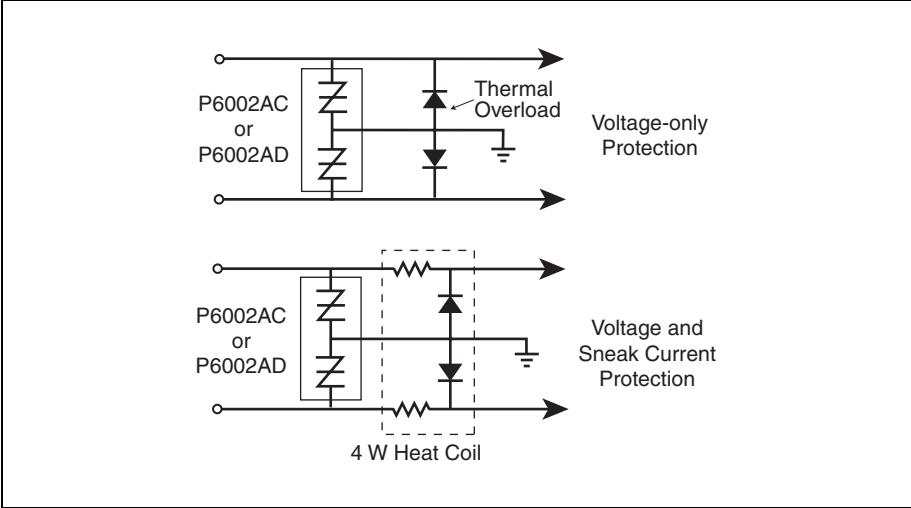

Figure 3.51 Primary Protection

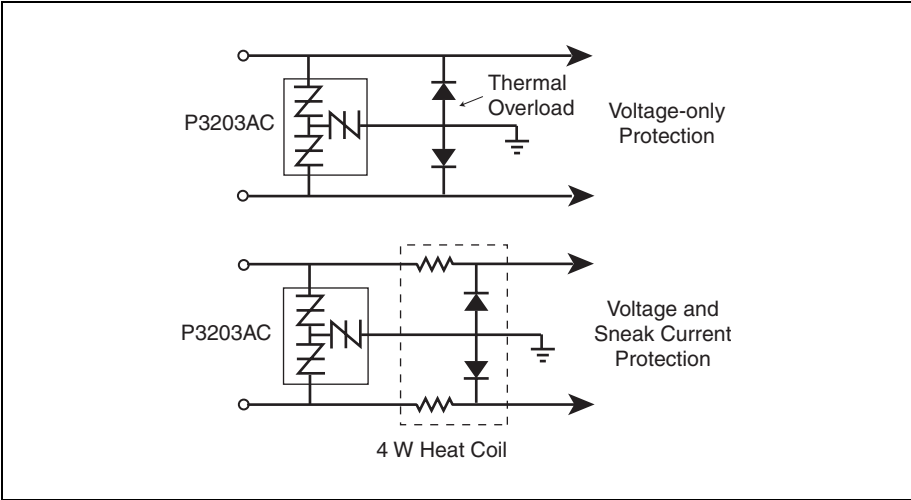

Figure 3.52 Balanced Primary Protection

Reference Designs