

Revision Control Record

Rev.	Description of Change	ECN No.	Date
A	RELEASED DRAWING	11031	2/3/11

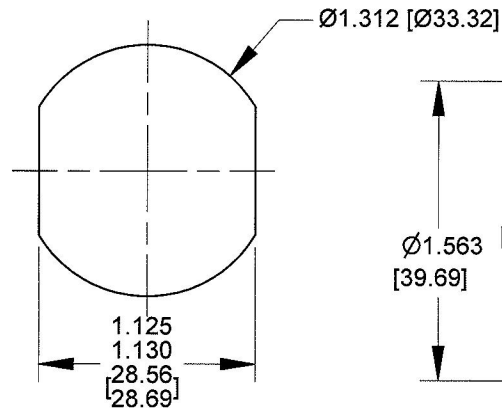

TYPICAL PANEL CUTOUT

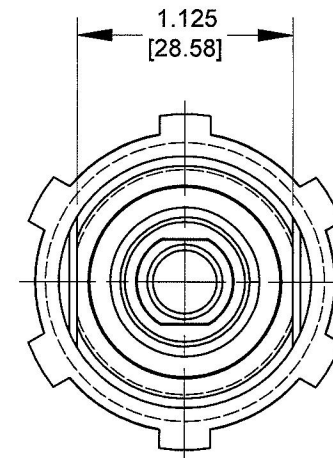
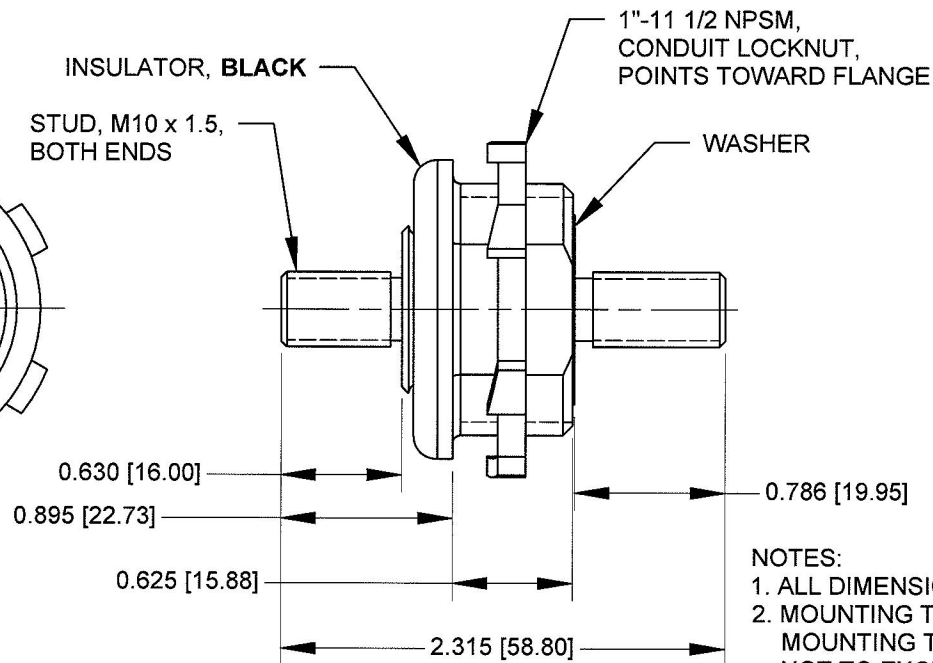
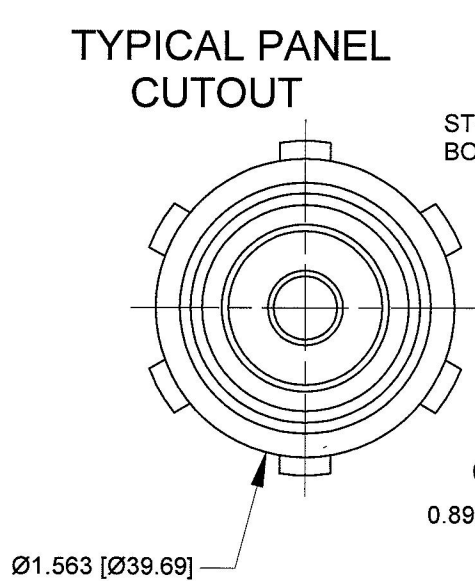
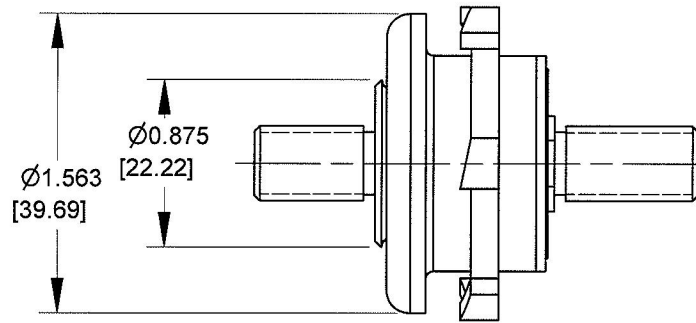

- NOTES:**
1. ALL DIMENSIONS ARE REFERENCE ONLY
 2. MOUNTING THREADS 1"-11 1/2 NPSM- MOUNTING TORQUE 8-10 FT LBS [10.8-13.5 Nm] NOT TO EXCEED 10 FT LBS [13.5 Nm]
 3. STUD M10 TIGHTENING TORQUE 6-8 FT LBS [8.1-10.8 Nm]

Tolerances Unless otherwise specifically noted, the following are default tolerances:
2-places **3-places** **Angular**
+/- 0.02" **+/- 0.005"** **+/- 1°**
 Metric: Shown in [] refers to equivalent English Dim Tol
 "REF." or an Asterisk (*) = Non-Toleranced Reference Dimension, shown for clarification purposes only.
 NOTE: All tolerances are Non-Cumulative.

PROPRIETARY INFORMATION This Engineering Drawing, and the information contained herein, is proprietary to Cole Hersee Company and may not be disclosed, re-produced, or in any other way transferred or communicated to any other party without the express written consent of an authorized representative of Cole Hersee Company.

Special Characteristics:

- Critical Characteristic, relating to Safety and/or Regulatory Compliance
- Significant Characteristic relating to Process Control
- Control Dimension relating to Form - Fit - Function as defined by Cole Hersee Company and/or the Customer

Cole Hersee Co.
 20 Old Colony Ave., South Boston, MA, 02127
 Phn: 617-268-2100 Web: www.colehersee.com

Description: **FEED THRU STUD**

Drawing / Part No.: **46211-12** Current Rev.: **A**