

HWB12 SEALED POWER DISTRIBUTION MODULE

Compact Hard-Wired PDM for 280 Style Components

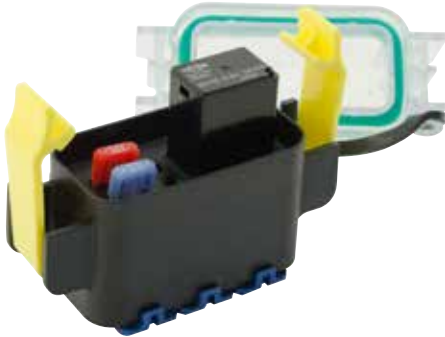

Description

The HWB12 Compact Hard-Wired Box features 12 cavities that accept 2.8mm fuse and relay components and is the perfect fit for accessory circuits and overflow circuits from your main Power Distribution module. The HWB12 can hold plug-in components including MINI fuses, MINI format circuit breakers, 4-pin single throw relays, and 5-pin double throw relays. The HWB12 features durable construction, an IP67/IP69K rating, and a compact size. The user can customize their own circuitry utilizing direct wire-to-component connections which are crimped to the wire harness with grommets to seal the bottom of the module.

Features and Benefits

- AssureLatch™ yellow positive-sealing latches keep the cover securely in place while allowing for fast service.
- Accepts any MINI (280 style) fuses, circuit breakers or relays.
- Compact size allows the unit to be installed in vehicles with limited space.
- Ideal for accessory circuits, overflow circuits from main
- IP67/IP69K sealed units can be installed virtually anywhere on the vehicle and stands up to road splash and salt spray.
- TPAs (terminal position assurance locks) give secondary locking protection of the wire leads, which help keeps leads securely in place.
- Wires plug into the back of the unit using industry-standard Tyco MCP terminals.
- Tethers available to prevent loss of cover during service.
- Optional foam on inside cover available; functions as relay retention insert
- HWB18, HWB12 & HWB6 share the same mounting bracket so electrical system modification can be performed without bracket or sheet metal alterations.

Specifications Overview

Max Fuse Rating:	30A per circuit
Max Continuous Current:	130A
Number of Cavities	12
Operating Temp:	-40 to +105 °C
Ingress Protection:	IP67/IP69K

Applications

- Accessory circuits
- Overflow circuits
- Main unit on small vehicles
- Upfitting vehicle electrical systems

Web Resources

Download 2D print and technical resources at:
littelfuse.com/hwb12

Ordering Information

PART NUMBER	COVER		AssureLatch™	GASKET	MOUNTING BRACKET
	BLACK	CLEAR			
PDM33001ZXM		•	•	•	
PDM33002ZXM	•		•	•	
PDM33003ZXM		•	•	•	Straight
PDM33004ZXM	•		•	•	Straight

Complete assembly includes: cover, base, gasket and TPAs
 TPA: Terminal Position Assurance secondary locks for wire terminals

Accessories and Service Parts

PART NUMBER	DESCRIPTION
8900470	Tether
868-964	Straight mounting bracket
868-068	30° angle mounting bracket
901-327	Foam insert

HWB12 SEALED POWER DISTRIBUTION MODULE

Specifications

Max Fuse Rating	30A per circuit
Max Continuous Current	130A
Number of Cavities	12
Recommended Mounting	M6 bolt and lock washer
Mounting Bracket Torque	5.5-6.5 Nm
Temperature Range	-40 °C to +105 °C
Ingress Protection Rating	IP67/IP69K
Dimensions	83.2x69.6x43.6 mm
Wire Sizes	0.35-2.50 mm ²
Mating Terminals & Seals	Tyco MCP Series. Sold separately.
Accessories	Optional: Cover tether, 30° angle bracket

Mating Terminals and Seals Compatibility

Wire Size Range (mm ²)	Insulation Diameter (mm) FLR	Materials and Finish	Part Number Strip Form	TE Cable Seal Part Number	Cable Seal Color
0.35-0.50	1.2-1.4	1-xxx-1/1-xxx-3	968882	828904-1	Blue
0.5-1.0	1.4-2.1	1-xxx-1/1-xxx-2/1-xxx-3	968855	828904-2	Blue
1.0-2.5	2.2-3.0	1-xxx-1/1-xxx-3	968857	828905-1	White
Empty Cavity	—	—	Cable Seal Plug	828922-1	Natural

Sold separately. Available from Tyco.

Dimensions in millimeters

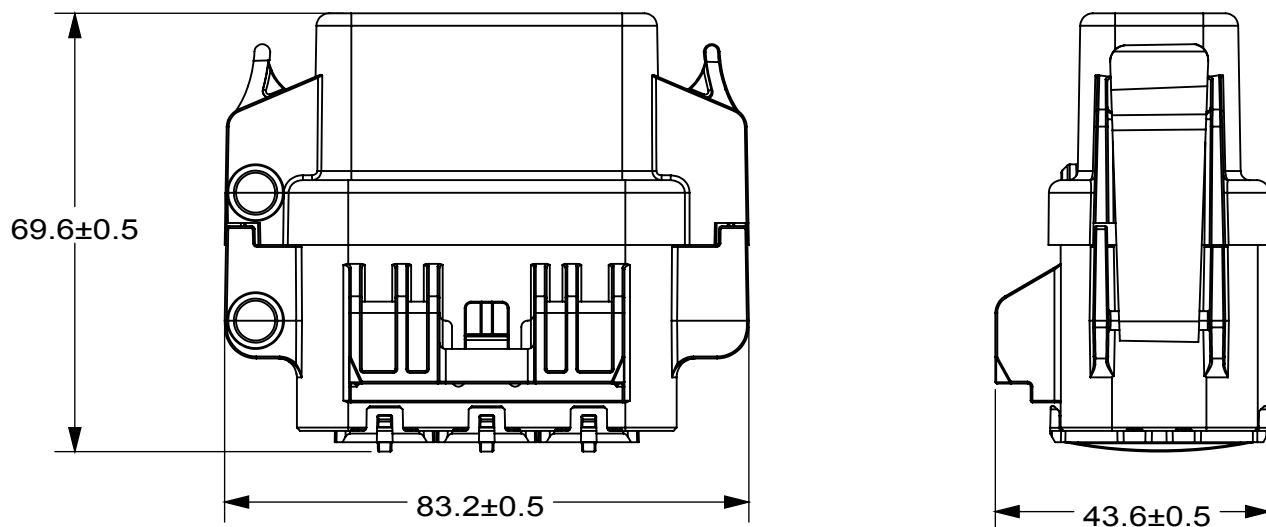

Visit Littelfuse.com for the most up-to-date product information. Littelfuse reserves the right to make product changes, without notice. Material in this document is as accurate as known at the time of publication.