

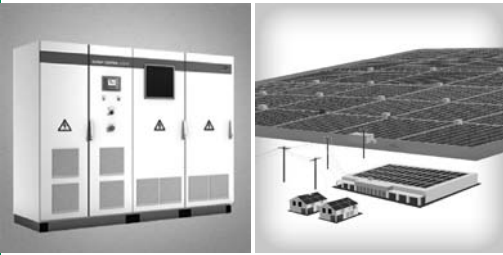

Expertise Applied | Answers Delivered



WHITE
PAPER



Tyler Klassen, P. Eng.
Littelfuse, Inc.

GROUND-FAULT PROTECTION

Ground-Fault Protection for Solar Applications

GROUND-FAULT PROTECTION FOR SOLAR APPLICATIONS

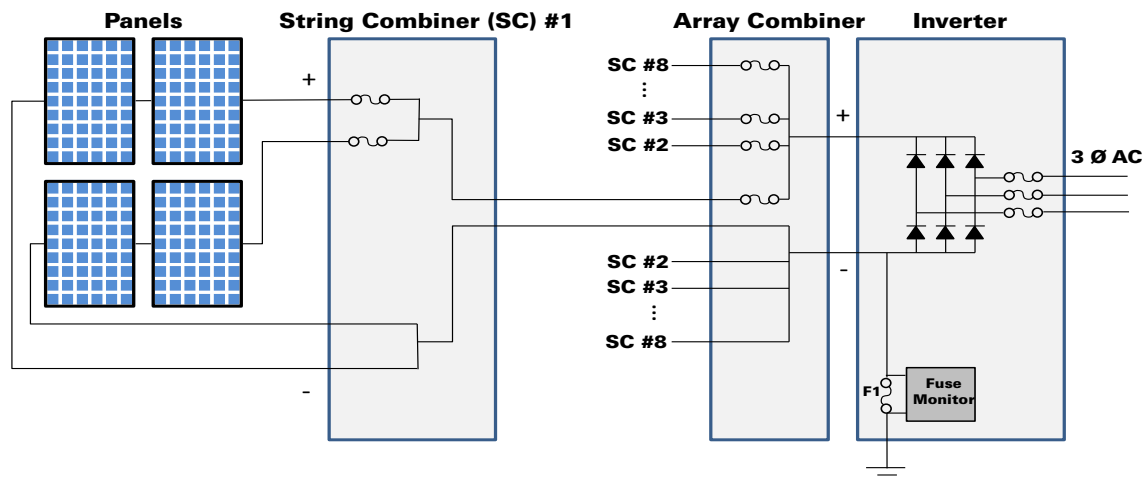

Figure 1: Grounded Negative Bus

Ground-Fault Protection for Commercial Solar PV Systems

Grid-connected commercial photovoltaic (PV) systems are trending towards larger sizes, resulting in systems with higher bus voltage and current levels. Problems caused by ground faults are becoming a bigger concern due to increased energy available at the point of fault; arc-flash and shock hazards, equipment damage, and fires can result.

When considering ground-fault protection, it is important to understand the difference between a grounded and an ungrounded system. A grounded system has one intentional connection from either the positive or negative bus to ground. Grounded PV systems are commonly used in North America. An ungrounded system has no intentional connections from either bus to ground. Ungrounded PV systems are commonly used in Europe and Asia.

Grounded System

A grounded system has a single connection from one bus to ground, always located at the inverter. This intentional ground connection is made through a fuse; the purpose of this fuse is to open when the ungrounded bus faults

to ground. A ground fault, defined as an unintentional connection of an energized conductor to ground, is a second path to ground and completes a loop, causing ground-fault current to flow. If the current exceeds the fuse rating, the fuse will open the loop and stop the ground-fault current from flowing.



Figure 3: Up-LINK Indicating Fuseholder

When a ground fault occurs with current in excess of the fuse rating, the fuse opens and the system becomes ungrounded. However, the unintentional ground connection (the ground fault) remains on the system until the equipment is repaired. A fuse monitor, such as an indicating fuse and fuseholder are required to alert maintenance personnel to the presence of the fault. The Littelfuse Up-LINK is a solid-state dead-front fuseholder that provides remote

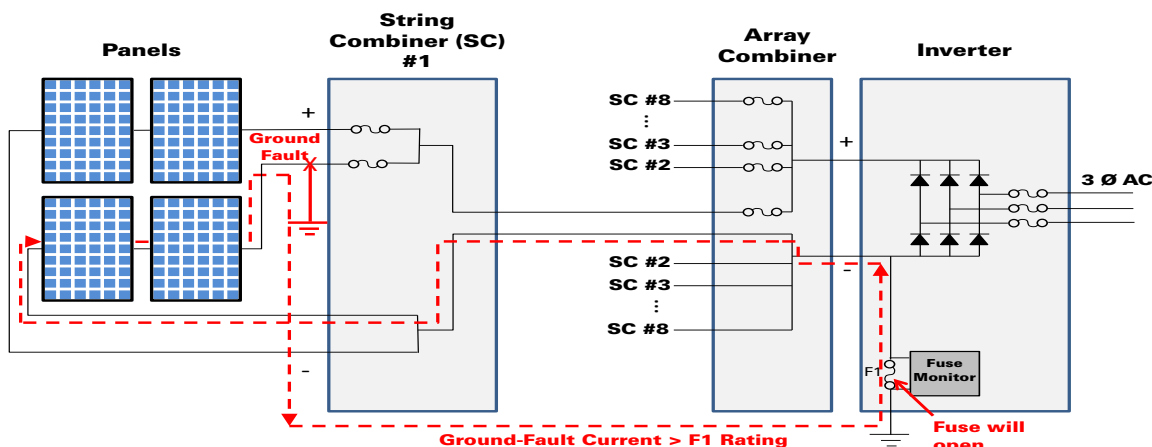

Figure 2: Grounded Bus with Ground-Fault Current > Fuse Current

GROUND-FAULT PROTECTION FOR SOLAR APPLICATIONS

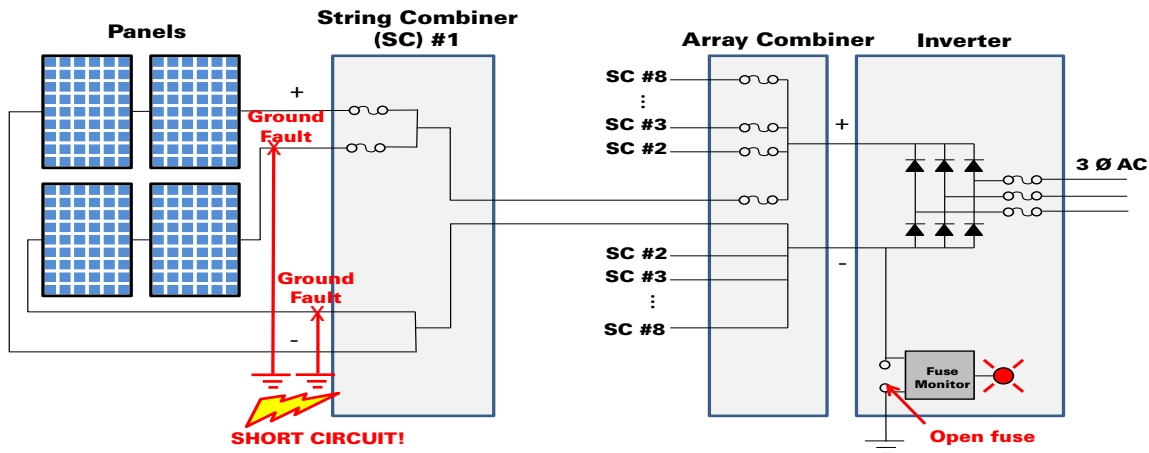

Figure 4: Second Ground Fault after Fuse Opens

fuse-status indication without the need for a proprietary network protocol. The Up-LINK also features local LED indication.

Without ground-fault sensing and a disconnect mechanism in the string combiner, the faulted cable will remain connected to the system after the first ground fault. The occurrence of a second ground fault, this time on the unfaulted bus, will cause a bus-ground-bus short, potentially causing a very large magnitude of short-circuit current, shock and arc-flash hazards, equipment damage, and fire. It is important to detect ground faults and deenergize the system in a coordinated manner before this hazardous condition can occur.

If a ground fault has impedance, the fault impedance will reduce the amount of ground-fault current. If the ground-fault current is less than the fuse rating, the fuse will not open. In addition, a ground fault on the grounded bus will likely not cause enough current to open the fuse. In an installation where wire resistance is present, a voltage drop in the grounded-bus cable will be present and may cause the fuse to open; however, this is not guaranteed. If a fault on the grounded bus does cause the fuse to open, the resulting voltage across the open fuse will be very low and the fuse monitor may not indicate that the fuse has

opened. Both of these examples illustrate a dangerous condition that allows the ground-fault current to remain on the system indefinitely. This can result in shock hazard, equipment damage, and fire. The ability to detect levels of ground-fault current below the fuse rating is important for system safety.



Figure 6: EL731 Earth Leakage Relay

The Littelfuse Startco EL731 is a microprocessor-based earth-leakage relay for grounded AC, DC, combined AC/DC, and variable-frequency power circuits. Earth-leakage metering, and two setting levels (trip and alarm) are provided. In addition to ground-fault protection, the EL731 has an input for a temperature sensor to provide metering and overtemperature protection.

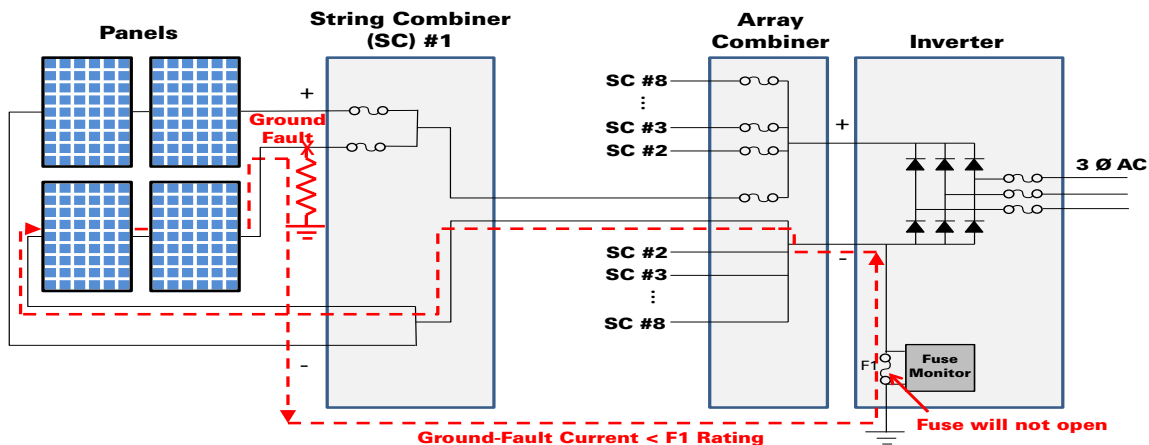

Figure 5: Grounded Bus with Ground Fault Current < Fuse Current

GROUND-FAULT PROTECTION FOR SOLAR APPLICATIONS

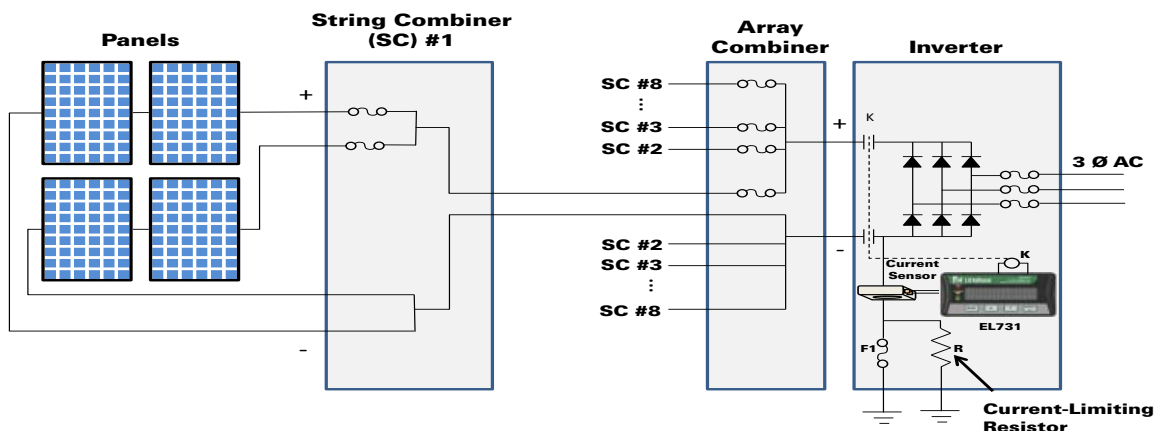

Figure 7: Grounded Bus with EL731 Earth-Leakage Relay

The EL731 uses sensitive EFCT-series current sensors to detect as little as 30 mA of ground-fault current. Ground-fault current sensing works on a core-balance principal; with no ground fault, the current on the positive bus will be equal in magnitude and opposite in polarity to the current on the negative bus; the summation of these currents is zero. When both the positive and negative bus cables are passed through the window of a

core-balance current sensor, this summation is what the current sensor reads. When a ground fault is present, some current will flow external to the current-sensor window in either the ground cable or some other path through ground. The positive and negative bus currents within the current-sensor window will no longer add up to zero; instead, they will add up to the amount of current flowing in the ground. A ground-fault current sensor can also be used to measure current when a single ground conductor is passed through the window. This method is used to monitor the inverter ground connection through the fuse. In an unfaulted system, there will be no current through this connection; during a ground fault, ground-fault current will flow through this connection.

The EL731 can be applied to a grounded PV system to detect ground-fault-current levels that are well below the fuse

rating, thereby lowering the levels of ground-fault detection and creating a much safer system. An EL731 is installed in the inverter, with the current sensor installed to monitor the negative-ground path through the fuse. In this location, an EL731 would detect a ground fault on the ungrounded bus anywhere on the system. Since the EL731 is much more sensitive than the grounding fuse, it is also much more likely to detect a ground fault on the grounded bus as well. However, the amount of ground-fault current that flows during the fault will depend on the resistance of the cables in the system, and may not be enough to trip the EL731.

The EL731 output contacts can be connected to a trip circuit used to isolate the inverter, or to an alarm circuit to alert maintenance personnel of the problem. The EL731 has LED trip indication on its faceplate, and optional network communications can be used to remotely send notification of a ground fault.

Ground-fault coordination is achieved by detecting a ground fault, removing or isolating the minimum amount of equipment required to clear the fault, and allowing the rest of the system to safely remain energized. In addition, ground-fault coordination greatly simplifies location of the fault for the maintenance team.

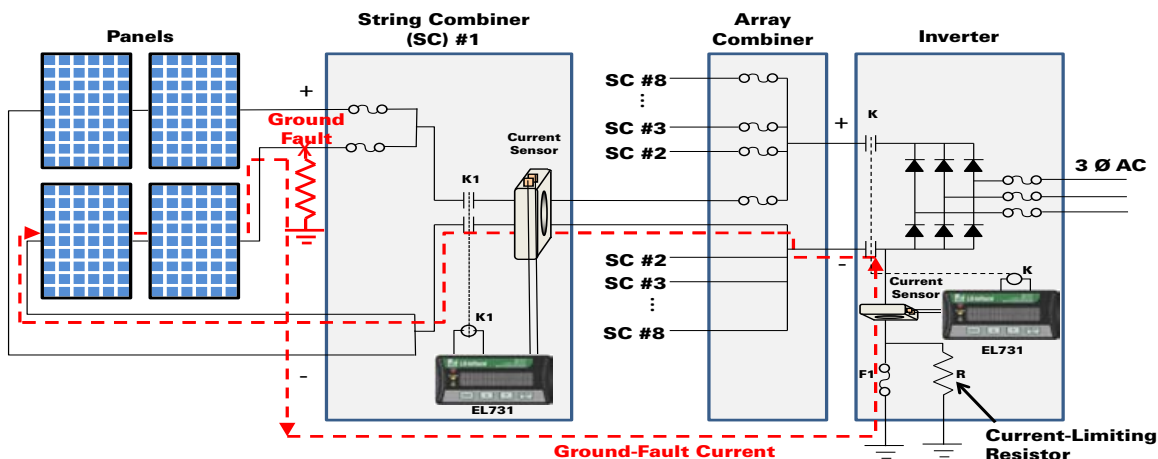

Figure 8: Grounded Bus with EL731 Earth-Leakage Relays in Inverter and String Combiner

GROUND-FAULT PROTECTION FOR SOLAR APPLICATIONS

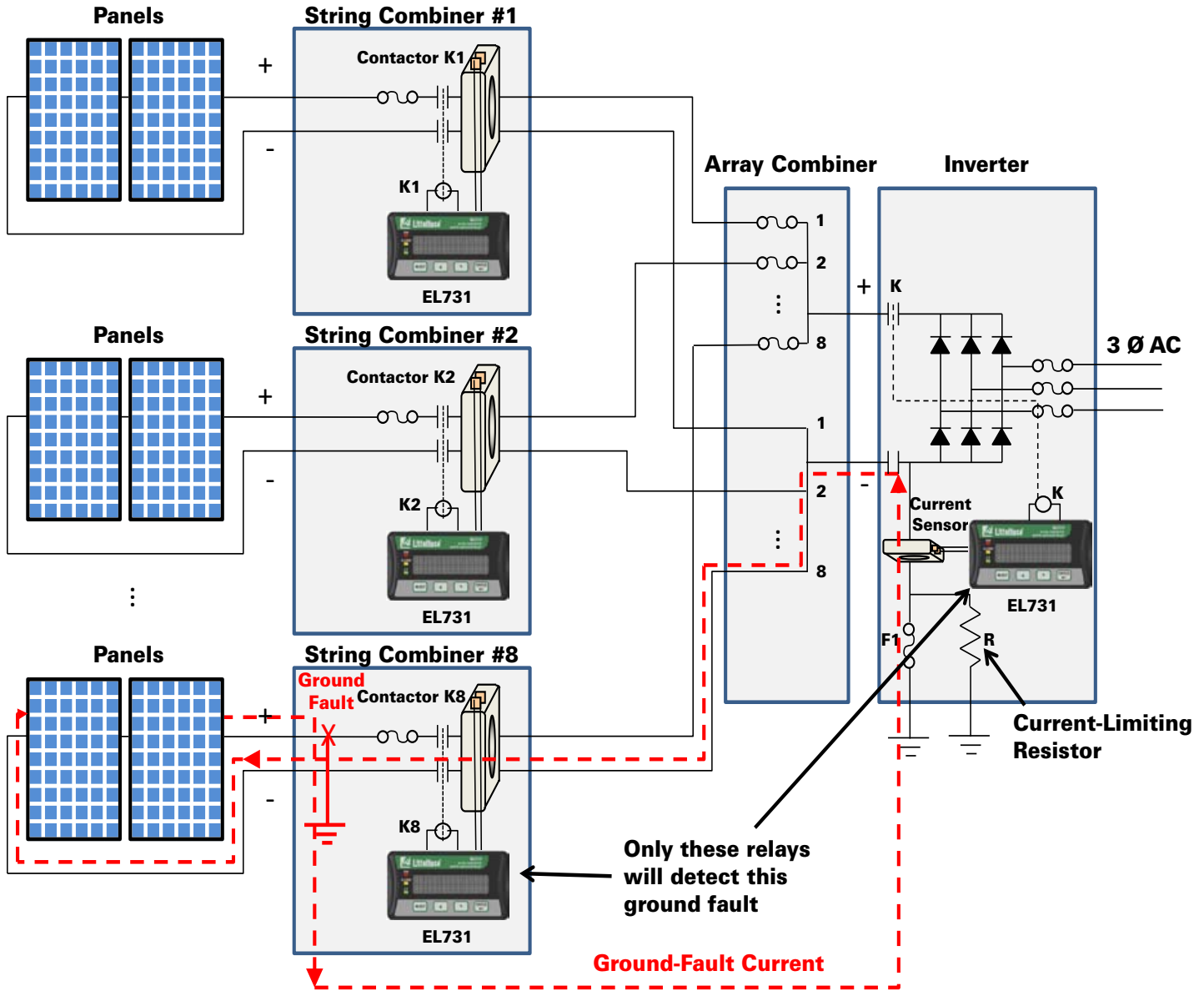

Figure 9: Grounded Bus with Coordinated Ground-Fault Protection

Proper ground-fault coordination uses time delays; relays closest to the system grounding point (inverter) are set to trip slowest, and relays further from the system grounding point are set to trip faster. If the first relay trips (the EL731 in the string combiner in the picture above) and removes the fault before the time delay of the second relay (the EL731 in the inverter) expires, the second relay will not trip and the rest of the system will continue to operate. The maintenance team would immediately be alerted to the presence of a ground fault and would know which array of strings it is on by seeing which relay is tripped.

To achieve ground-fault coordination over the entire system, one EL731 and one contactor or breaker is installed in each combiner box. Each EL731 only detects a ground fault in the array of strings connected to its combiner box; it would not detect a ground fault in any other array of strings. When a ground fault occurs in an array, the corresponding EL731 will trip; the relay's output contacts will then trip a switch, breaker, or contactor to remove the faulted array from the system.

GROUND-FAULT PROTECTION FOR SOLAR APPLICATIONS

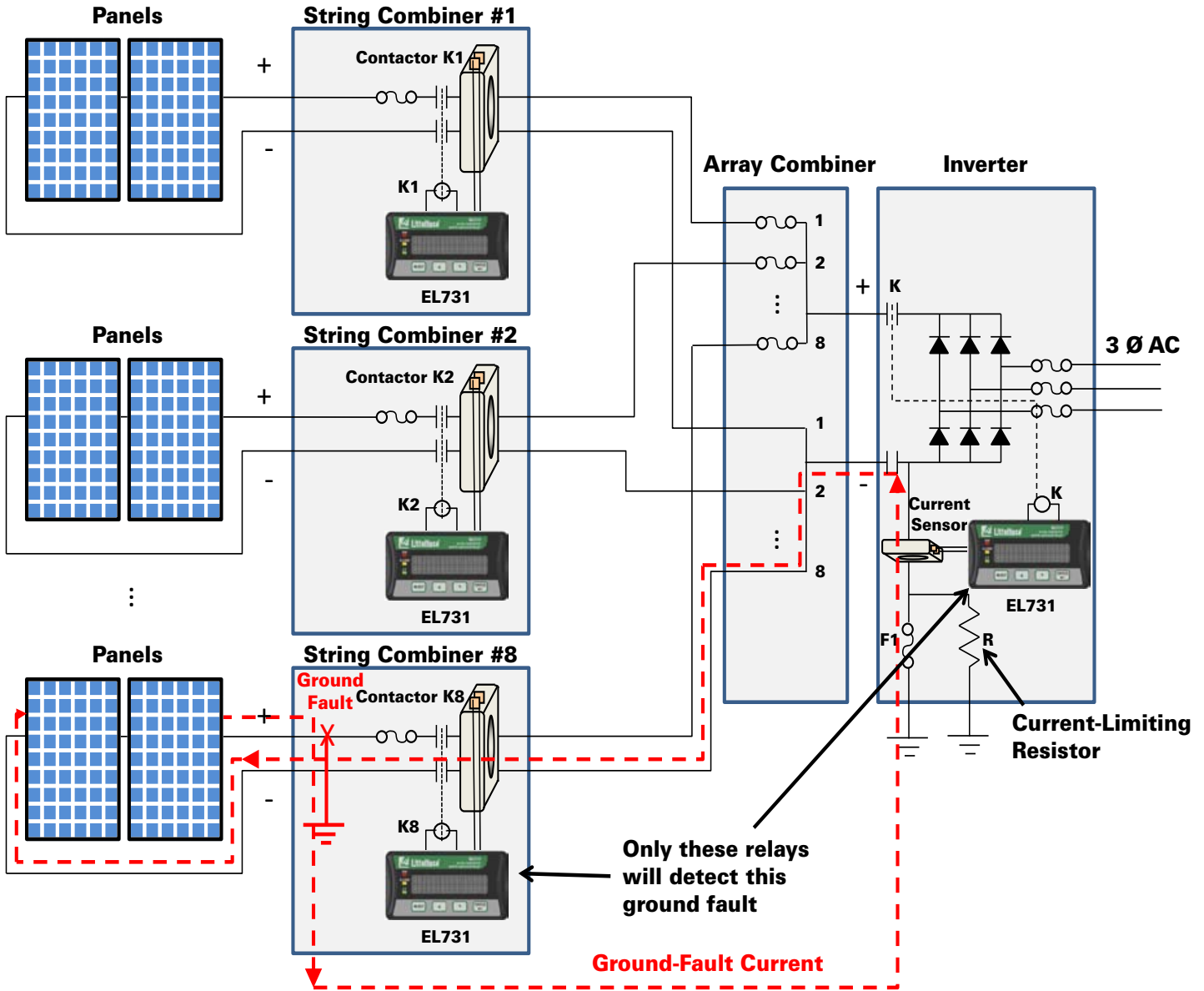

Figure 10: Grounded Bus with Coordinated Ground-Fault Protection and Open Fuse

An EL731 installed in the inverter is backup protection and also protects the circuit between the string combiners and the inverter. This EL731 is set with an extended trip delay to give the EL731 in the string combiner the chance to trip first.

A current-sensing relay, such as the EL731, requires the system to remain grounded long enough to detect the fault and to allow any programmed trip-time delays to expire. Since the programmable trip-time delay in the EL731 is 0 to 2 seconds, a ground-fault would remain on the system for a maximum of 2 seconds. If the fuse opens before the relay trips, the ground-fault current goes to zero, and the relay, no longer detecting ground-fault current, will not trip. To guarantee ground-fault coordination, a 5 A current-limiting resistor, R, is connected in parallel with the grounding fuse.

When the fuse is closed, R will be shorted out and has no effect on the system; current-sensing ground-fault relays will operate normally. If a high-current ground fault occurs and causes the fuse to open, the current-limiting resistor R will allow a controlled amount of ground-fault current for the relays to detect and isolate the fault. Once the faulted array is isolated by the coordinated ground-fault relays, the current through the resistor R will return to zero.

GROUND-FAULT PROTECTION FOR SOLAR APPLICATIONS

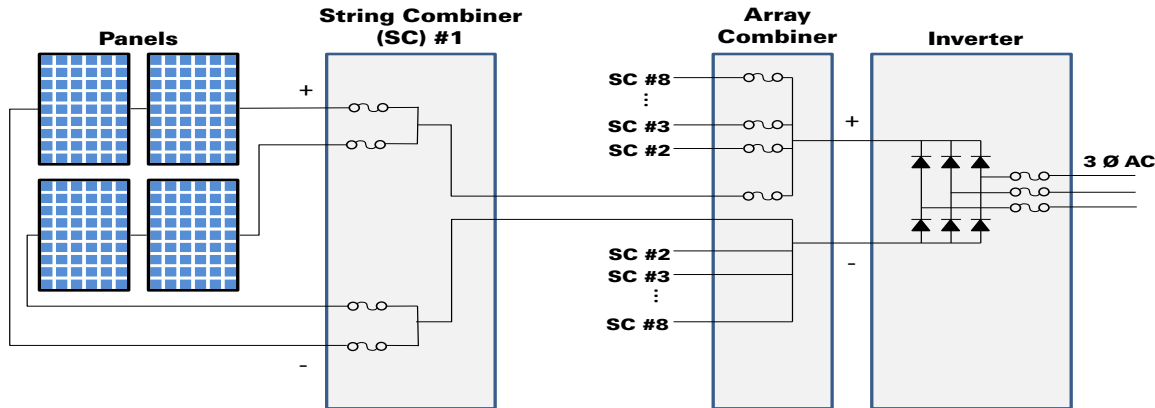

Figure 11: Ungrounded Bus

Ungrounded System

An ungrounded system is defined as having no intentional connection to ground. An ungrounded system presents a problem for ground-fault detection. Since the bus has no intentional connection to ground, a ground fault will not close a loop and ground-fault current will not flow. Current-sensing ground-fault relays cannot be used. It is worth noting that when the first ground fault occurs on an ungrounded system, the system now becomes a grounded system through the fault until the fault is repaired. This is not desirable as a subsequent ground fault occurring on the unfaulted bus will cause a bus-ground-bus short circuit, resulting in short-circuit currents, with possible arc-flash, fire, and shock hazards.

On an ungrounded system, insulation monitors are typically used to measure bus-to-ground resistance. With no ground fault, the monitor will measure a very high value. When a ground-fault occurs, this value decreases and the monitor responds accordingly. To measure resistance to ground on a DC system, insulation monitors inject an AC or pulsed DC signal onto the bus. Insulation monitoring has two difficulties; the first is that the capacitance of the system to ground presents a path to ground to the insulation monitor, and if large enough, will cause a nuisance trip. Since capacitance is a function of the PV system size, larger systems will have higher capacitance and are more prone to nuisance trips.

The second problem is selective coordination is not possible with insulation monitoring; an insulation monitor will detect a fault anywhere on the system. Troubleshooting and fault location are difficult and time consuming.

Resistance-Grounded System

The solution to these problems is to ground the system, either by grounding the negative bus through the methods described in the Grounded System section, or by a more novel approach that approximates a popular grounding technique used on AC systems. On an AC system, the safest and most stable distribution system is high-resistance grounded. A high-resistance-grounded system uses a neutral-grounding resistor to connect the neutral point of a wye (star) transformer secondary to ground. The benefits of a high-resistance-grounded system are limiting ground-fault current to a low level, elimination of transient overvoltages, elimination of arc flash hazards caused by a ground fault, and the ability to use selective coordination for ground-fault protection. Many of these benefits can be achieved on a DC system by grounding with a resistor network. In addition, a ground fault on either bus can be reliably detected on a resistance-grounded system.

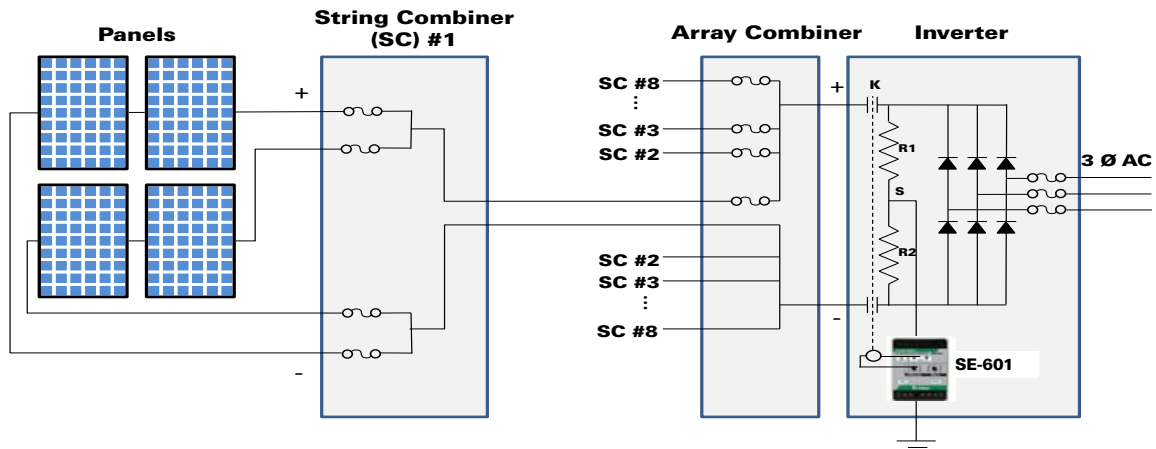

Figure 12: Resistance-Grounded System

GROUND-FAULT PROTECTION FOR SOLAR APPLICATIONS

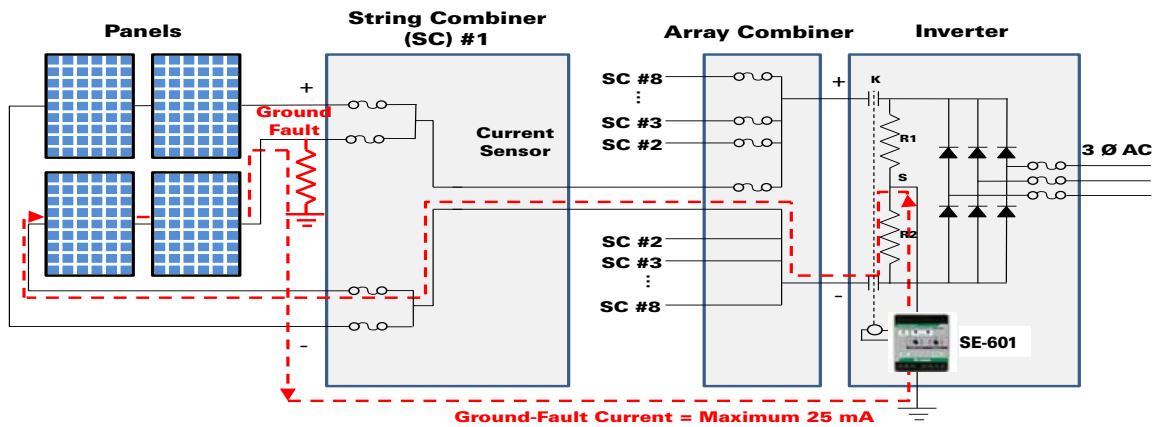

Figure 13: Resistance-Grounded System with Ground Fault

To implement high-resistance grounding on a DC system, a “neutral” or zero-voltage point must be first established. This can be achieved through the use of matched resistors, R1 and R2. These two resistors are connected in series between the positive and negative bus. The centre point, S, is connected to ground through a SE-601 DC Ground Fault Monitor.

The SE-601 is a microprocessor-based ground-fault monitor for dc systems, designed to monitor a resistance-grounded system.

The trip level of the ground-fault circuit is selectable from 1 to 20 mA, and trip time is selectable from 0.05 to 2.5 s.

When used with the SE-601, the resistor network is designed to limit the ground-fault current to 25 mA, and to allow a nominal unfaulted current of 12.5 mA. The total required resistance between the positive and negative bus is calculated using Ohm’s law; $R_{Total} = V/I$. For example, on a 1,000-Vdc bus, the total required resistance is $R_{Total} = V/I = 1,000/0.0125 = 80 \text{ k}\Omega$. When there is no ground fault on the system, the voltage at the centre point of this resistor network, S, is 0V, and no current flows through the S-to-relay-to-ground conductor. When a ground fault occurs on either bus, the voltage across one resistor rises to full bus voltage, causing 25 mA of current to flow through it, the S-to-ground connection, and the SE-601. The SE-601 detects this current and trips.



Figure 14: SE-601 DC Ground Fault Monitor

To achieve proper ground-fault detection and coordination for both buses, a resistor network can be used along with an EL731 and breaker or contactor at each combiner box.

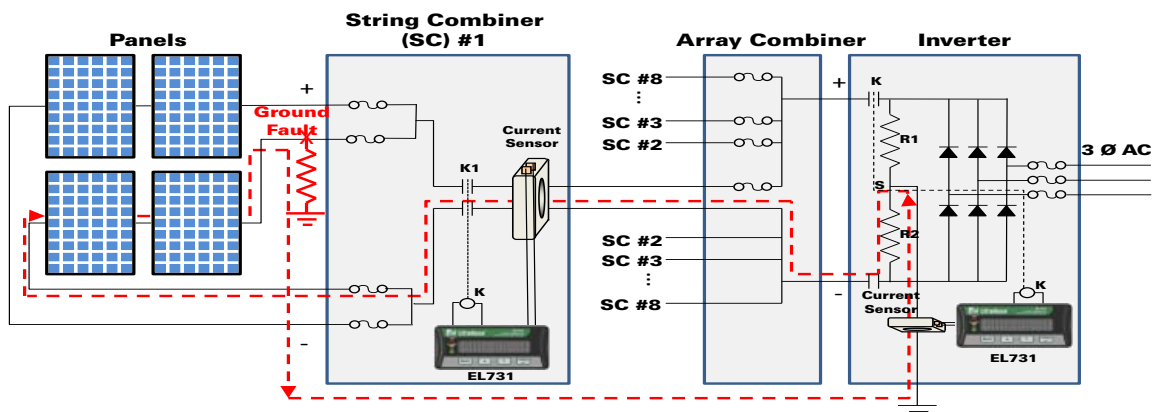

Figure 15: Resistance-Grounded System with Coordinated Ground-Fault Protection

GROUND-FAULT PROTECTION FOR SOLAR APPLICATIONS

Conclusion

A grounded system is superior to an ungrounded system as it allows the use of current-sensing ground-fault relays to quickly and accurately detect low levels of ground-fault current. A system with one bus grounded through a fuse and current-limiting resistor allows ground-fault protection for the ungrounded bus; however, ground-fault detection and protection for the grounded bus is not guaranteed. A system that is resistance grounded through a resistor network is the best solution, as it allows ground-fault detection and protection for both buses. Relays and disconnect mechanisms are installed at each combiner box to detect a ground fault and remove the minimum amount of equipment to clear the fault. Not only is this system the safest, it is the most convenient to maintain and will reduce system down time.