

REVISION		
REV	DATE	DESCRIPTION
A	10/13/22	525740GCP - RELEASE MRY

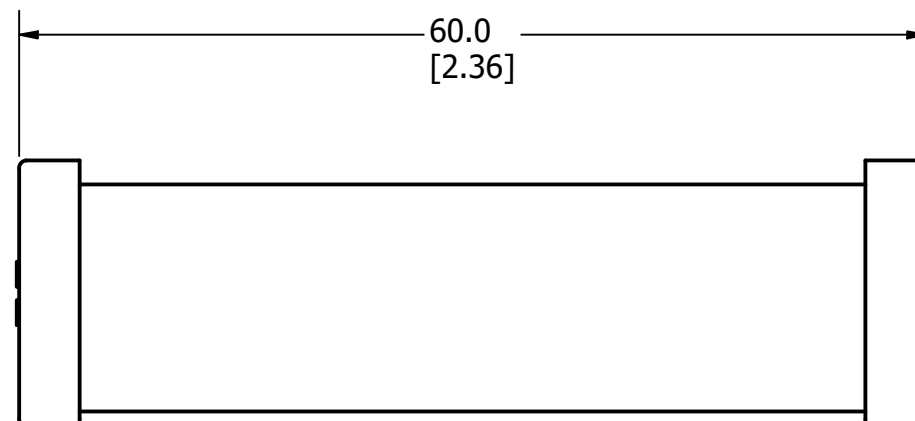
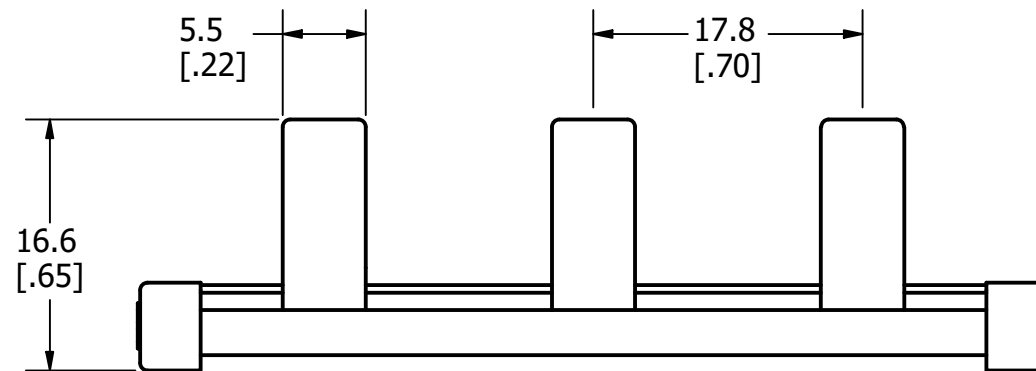
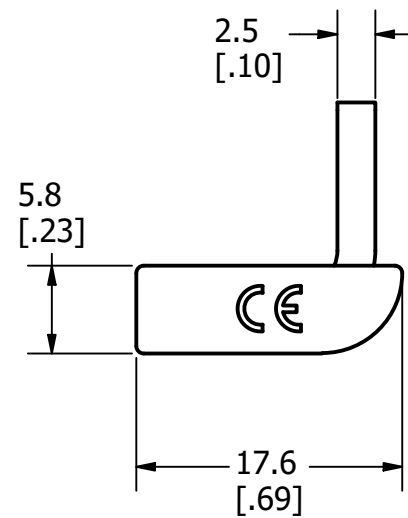
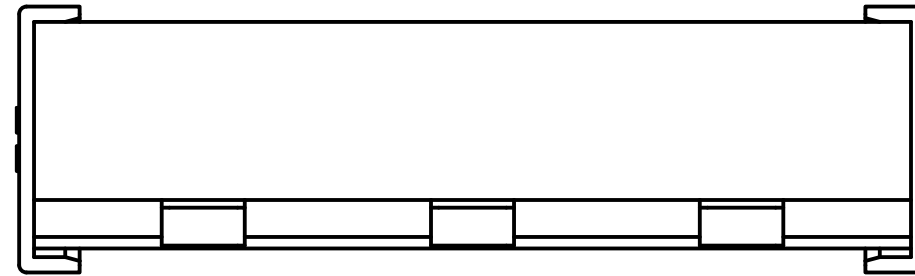

1	NO	COMPONENT NO	DESCRIPTION	QTY/M	U/M
<b>BILL OF MATERIAL</b>					
<S>	CRITICAL CHARACTERISTIC FOR PART SAFETY/COMPLIANCE				
●	DENOTES CRITICAL CHARACTERISTICS.				
CPK	DENOTES CPK DIMENSIONS, -MINIMUM CPK VALUE				
⊆	DENOTES A CHARACTERISTIC THAT PROVIDES AN INDICATION OF PROCESS PERFORMANCE. PROCEDURE FOR MEASUREMENT AND TRACKING TO BE DEFINED IN LITTELFUSE INSPECTION INSTRUCTIONS.				
CP	DENOTES CP DIMENSIONS, -MINIMUM CP VALUE MUST BE WITHIN THE DIMENSIONAL LIMITATIONS SHOWN ON DRAWING AND INITIALLY LOCATED TO ALLOW FOR MAXIMUM TOOL LIFE.				
MATL SPEC			FINISH		
DRW JMOLER	DATE 10/3/2022	SCALE NTS	FINISH GOOD WT GRAMS/PIECE		
UNLESS OTHERWISE SPECIFIED, DIMENSIONS ARE IN MILLIMETERS, DIMENSIONS IN BRACKETS [ ] ARE INCHES DIMENSIONING AND DO NOT INCLUDE PLATING. TOLERANCING TO BE INTERPRETED IN ACCORDANCE WITH ANSI Y14.5M-1994					
3RD ANGLE PROJECTION					
<b>TITLE</b> 1PH3P25MM OUTLINE					
<b>Littelfuse</b> CHICAGO, ILLINOIS 60631		REVISION A	DRWG NO. OL-1PH3P25MM	SHEET 1 OF 1	

**B**