

COLE-HERSEE CO.

MM
 .25
 6.35
 10.06
 15.74
 18.78
 22.60
 28.44
 32.51

IN
 .010
 .250
 .420
 .620
 .720
 .890
 1.120
 1.280

5011 REV

| SEQ. | DEPT. | OPERATING INSTRUCTIONS | DIE | MACH. |
|------|-------|------------------------|-----|-------|
| | | | | |
| | | | | |
| | | | | |

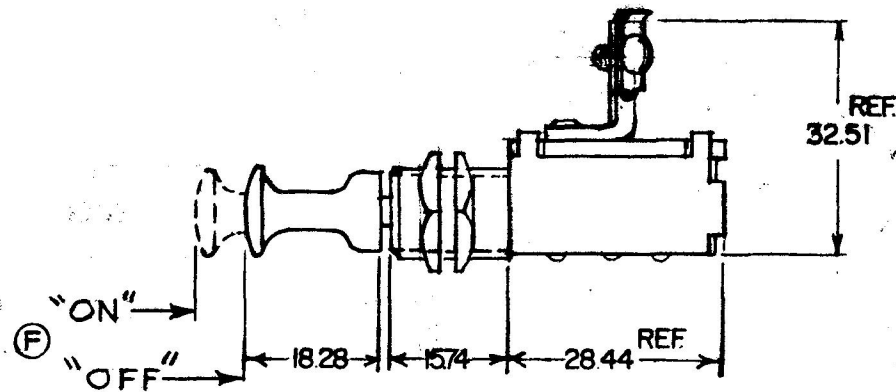
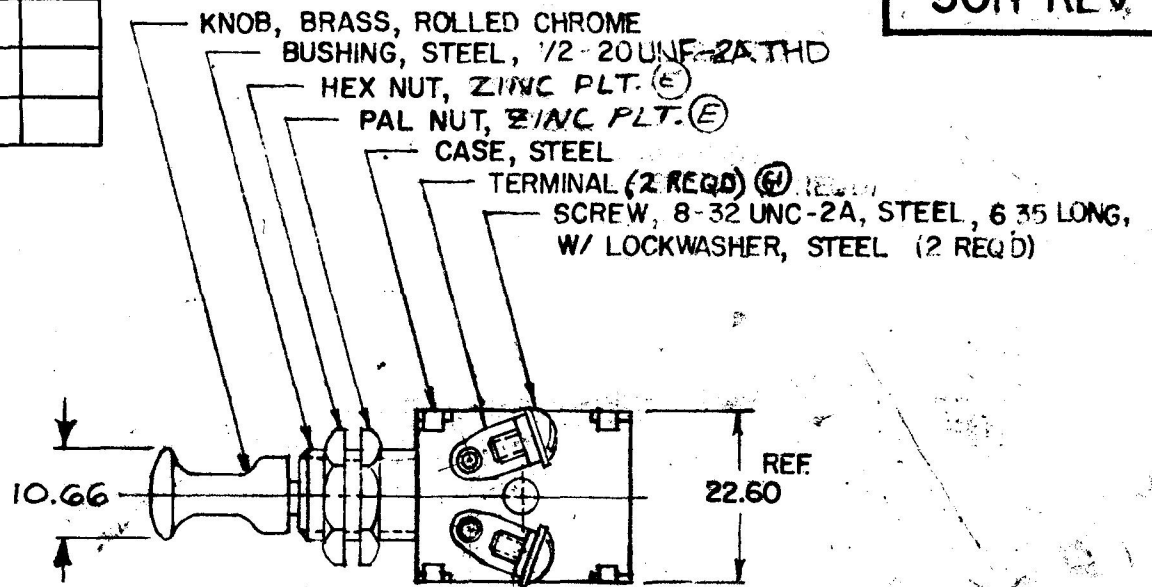
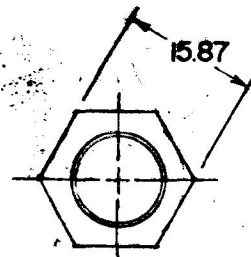

METRIC

NOTE:
 (G) ALL STEEL PARTS PLATED INO PLT. W/
 DIE CASTING

DO NOT SCALE

| LET | WAS | DATE | BY | LET | WAS | DATE | BY | MATERIAL | DRAWN | CHECKED | APPR'D. | SCALE | DATE DRAWN |
|-----|-----|------|----|-----|-----|------|----|--------------|---|---------|---------|-------|-------------------------|
| | | | | | | | | | EHD | 1-31-79 | | 1:1 | 2-19-59 |
| | | | | | | | | FINISH | COLE-HERSEE COMPANY BOSTON, MASS. 02127, U.S.A. | | | | DATE BLUEPRINT |
| | | | | | | | | TOLERANCES | | | | | PUSH-PULL SWITCH |
| | | | | | | | | FRACTIONAL ± | | | | | |
| | | | | | | | | DECIMAL ±.25 | | | | | |

SPAULDING CO., INC.