

CASE STUDY

Bee Cave Drilling

Utilizing Littelfuse PumpSaver®

SITUATION

Bee Cave Drilling is a residential and commercial water well driller located in Dripping Springs, Texas. They drill the well and install the well casing, pump and auxiliary equipment that delivers a complete solution that is exactly what their customers are looking for—water. With drought conditions occurring across several areas of the US and residences and businesses relocating to remote areas outside of city water limits, providing water to these areas is a growing business for Bee Cave Drilling.



Figure 1. The 777 KW/HP-P2

Jim Blair, company owner, also attributes much of this growth to treating his customer right.

“We provide pump systems at an affordable price with only high quality products to make sure they keep working for years to come. We have to provide products that keep working, that’s very important to me.”

Not only do exceptional service and products guarantee repeat business for future needs, but also referrals for new customers with water pumping needs.

Bee Cave Drilling began installing PumpSaver products on the pumps they sell, install and repair for customers. While using these Pump Saver products, the number of pump failures has dramatically decreased, while customer satisfaction has increased.

Most pump failures are not due to the poor quality of the pump itself, but rather several environmental events which may occur. Common causes of failure include: continuing to run the pump after the well has run dry, iron bacteria and debris jamming the impeller or an electric source providing an improper voltage level. Each of these conditions can cause the windings in the pump motor to heat up and eventually fail.

PumpSaver products stop the pump from running in these hazardous conditions, hence saving the pump.

Whether the pump is running off single-phase or three-phase power, there is a PumpSaver solution which can keep the water flowing to the customer's door while saving them costly service repairs, pump replacement expenses and the time and frustration of having to deal with the failure.

Bee Cave Drilling installs the 233P, 235P, and 777-KW/HP-P2 PumpSaver models. Both the 233P and 235P are 230 V single-phase models designed to protect pumps from improper voltage, current and last fault information.

Blair estimates he's installed over 500 pumps this year and each one includes a Littelfuse PumpSaver product. Blair added, "We don't service a pump unless it gets protection."

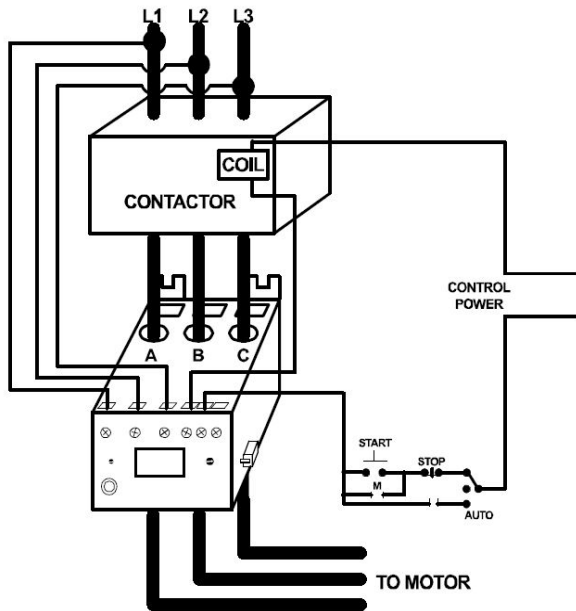

Figure 2. Typical wiring diagram of a 777 PumpSaver

The 233P model protects pumps from 1/3–3 Hp, while the model 235P is for 230 V 5–15 Hp pumps. Both models can be mounted in a separate pump control panel or pre-mounted in a weather-proof enclosure from Littelfuse. Other PumpSaver products include the 231-Insider-P for use on 230 V pumps using Pentek®, Franklin® or Centripro® control boxes, the 232-Insider for 230 V pumps using Grundfos® control boxes and the 111P and 111-Insider-P for 115 V pumps.

Blair also uses a Littelfuse hand-held diagnostic tool called the Informer. The Informer allows him to go to any panel with an installed single-phase PumpSaver and wirelessly download the past 20 fault causes. This product aids in determining and resolving the issue.



Figure 3. Littelfuse Informer

"The Informer is an invaluable tool for us to help figure out what problems are occurring and provide a solution to our customers. It's a good tool to go back and get history on peaks and low voltages," says Blair. "It saves us time and frustration and gets the water flowing again quicker, which makes the customer happy." Blair's parting comment to all of his customers is, "Having a PumpSaver on your pump is like having a pump man watching your pump 24 hours a day, 7 days a week."

The cost of a PumpSaver is relatively small compared to the cost of replacing a failed pump and lost resources while it's down. In today's competitive markets, Bee Cave Drilling uses any tools it can to keep loyal customers coming back and referring other customers their way. Littelfuse products will continue to be an integral part of ensuring their customers are happy and having running water for years to come.

"Having a PumpSaver on your pump is like having a pump man watching your pump 24 hours a day, 7 days a week."

*Pentax, Franklin, Centripro, and Grundfos are trademarks of their respective owners.