

REVISIONS				
ZONE	REV.	DESCRIPTION	DATE	APPROVED
	A	PCO-500000301383 INITIAL RELEASE	AUG./20/2025	D. ZHANG

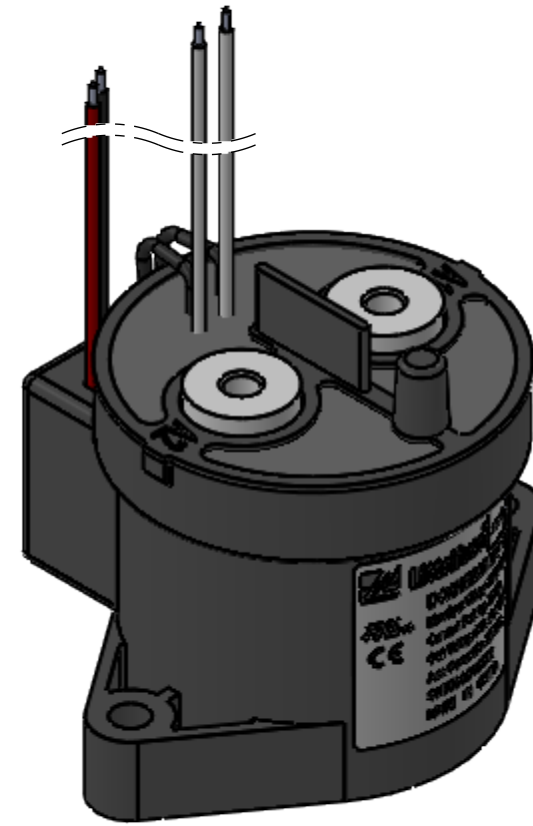

DCNHE250MF SERIES SCHEMATIC CIRCUIT DIAGRAM

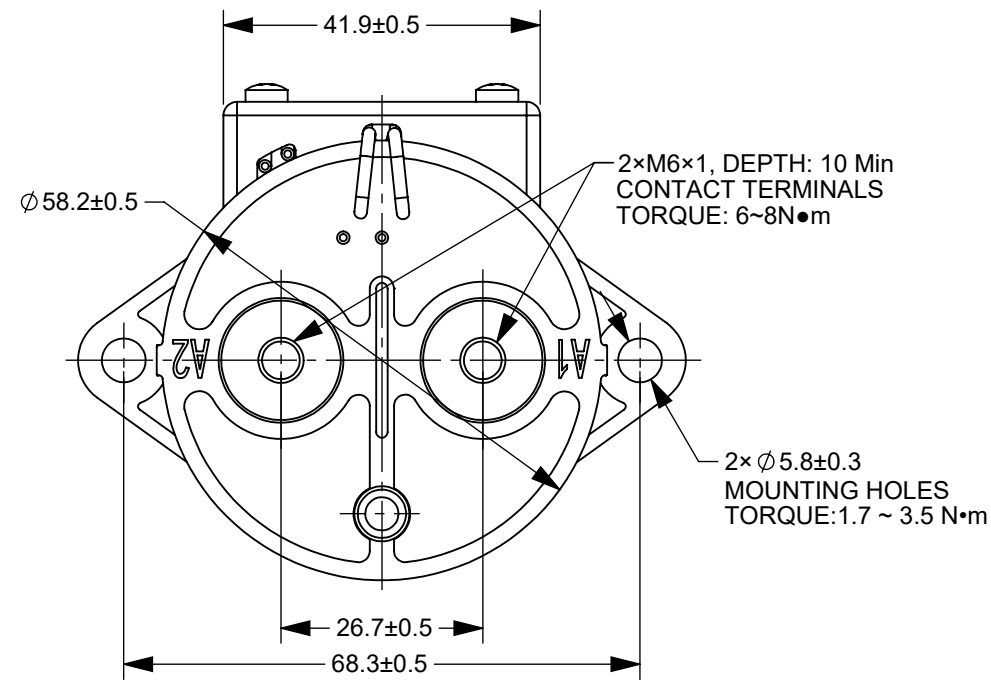
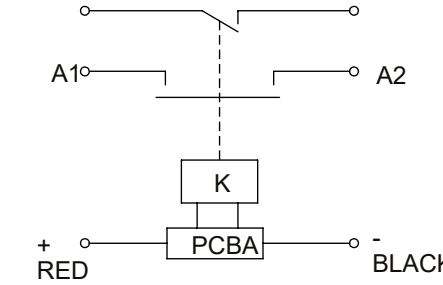

DCNHE250UF SERIES SCHEMATIC CIRCUIT DIAGRAM

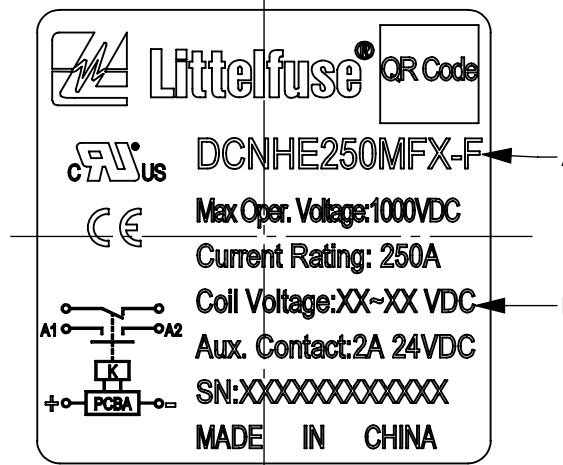
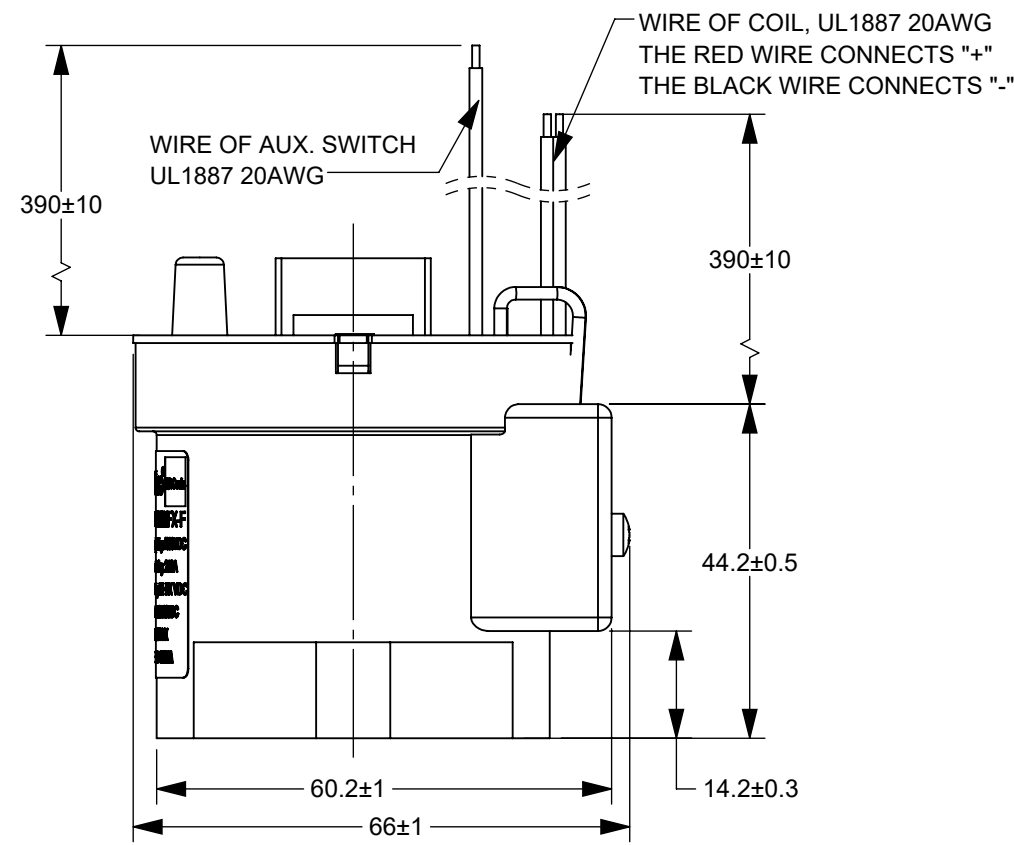
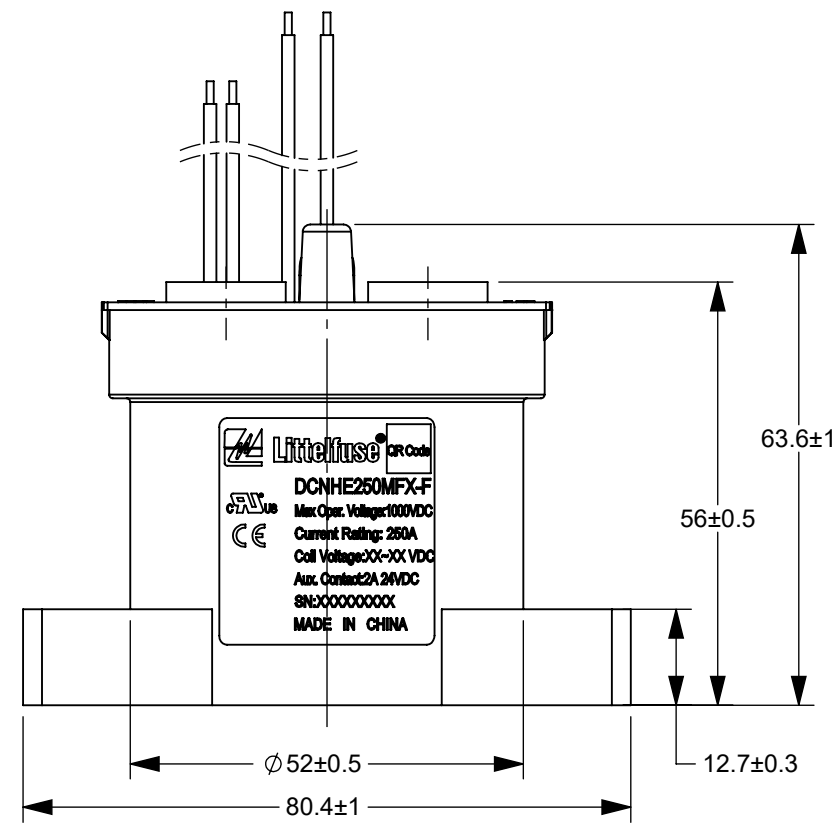
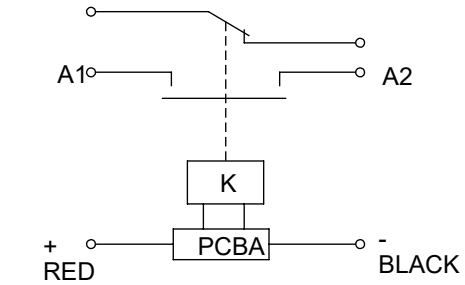

VIEW 1 SCALE 2:1

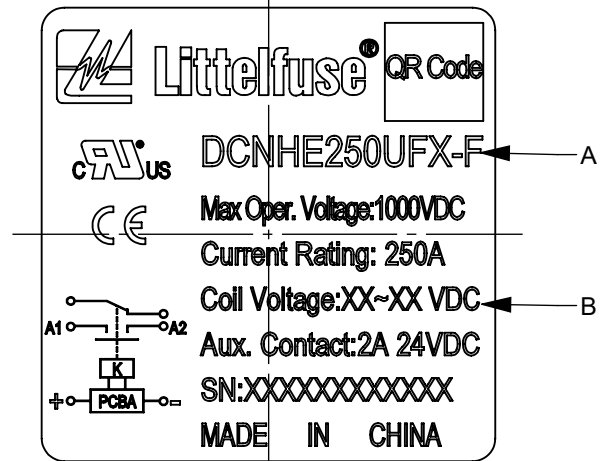

VIEW 2 SCALE 2:1

TABLE 1

PN		DCNHE250MFA-F DCNHE250UFA-F	DCNHE250MFB-F DCNHE250UFB-F
MAX. OPERATING VOLTAGE		1,000V DC	
RATED CONTACT CURRENT		250A	
COIL VOLTAGE		12~36V DC	32~95V DC
OPERATING VOLTAGE IN COLD STATE@25°C	PICK-UP	8~9V DC	30~32V DC
	RELEASE	5~7V DC	17~20V DC
STARTING CURRENT@25°C		2.4A@12V DC 2A@24V DC	0.7A@48V DC
HOLDING POWER@25°C		APPROX. 2.5W	
VOLTAGE DROP		≤80mV@250A	
Max. BREAKING CURRENT		2,000A@320V DC, 1CYCLE	
INSULATION RESISTANCE@500V DC (INITIAL)		≥100MΩ	
DIELECTRIC STRENGTH (LEAKAGE CURRENT≤1 mA)	BETWEEN CONTACTS	4,000V AC, 1 MINUTE	
	BETWEEN CONTACTS AND COIL	2,200V AC, 1 MINUTE	
	BETWEEN OPEN AUX. CONTACTS	1,000V AC, 1 MINUTE	
ELECTRIC LIFE (RESISTIVE LOAD)		6,000 CYCLES (250A@450V DC)	
		500 CYCLES (250A@750V DC)	
		1,000 CYCLES (100A@1000V DC)	
MECHANICAL LIFE (NO LOAD, CYCLES)		300,000	

TABLE 2

NO.	PN	"A"	"B"	CERTIFICATIONS	REMARK
1	DCNHE250MFA-F	DCNHE250MFA-F	Coil Voltage:12~36VDC	UL,CE	NAMEPLATE:VIEW 1
2	DCNHE250MFB-F	DCNHE250MFB-F	Coil Voltage:32~95VDC	CE	
3	DCNHE250UFA-F	DCNHE250UFA-F	Coil Voltage:12~36VDC	CE	NAMEPLATE:VIEW 2
4	DCNHE250UFB-F	DCNHE250UFB-F	Coil Voltage:32~95VDC	CE	

NOTES:

- ALL DIMENSIONS ARE REFERENCE ONLY.
- CONTACTOR PARAMETERS ARE SHOWN IN TABLE 1, CERTIFICATIONS INFORMATION ARE SHOWN IN TABLE 2.
- SEE TABLE 2 FOR NAME PLATE AND PNs.
- PRODUCT TYPE: SPST-NO, NON-POLAR CONTACTOR WITH AUXILIARY CONTACT; AUXILIARY TYPE: SPST-NO OR SPST-NC.
- MATERIALS AND FINISH:
 - HOUSING: THERMOPLASTIC PLASTICS.
 - CONTACTS: SILVER-PLATED COPPER.
 - CONTACT STUDS: SILVER-PLATED COPPER.
- WEIGHT: ABOUT 450GRAMS.
- RoHS COMPLIANT.
- THE COIL OF THE CONTACTOR IS POLAR, SO THE CONNECTION OF THE COIL SHOULD BE OPERATED ACCORDING TO THE SCHEMATIC CIRCUIT DIAGRAM.

DIMENSIONS ARE SHOWN IN MILLIMETERS. DIMENSIONS AND TOLERANCES ARE DEFINED ACCORDING TO ANSIA/ASME Y14.5-1994.		
●	FIT/ FUNCTION CRITICAL CHARACTERISTICS	
<S>	SAFETY/ COMPLIANCE CRITICAL CHARACTERISTICS SYMBOL	
CPK	DENOTES CPK DIMENSIONS MINIMUM CPK VALUE	
(ST)	DENOTES A CHARACTERISTIC THAT PROVIDES AN INDICATION OF PROCESS PERFORMANCE.PROCEDURE FOR MEASUREMENT AND TRACKING TO BE DEFINED IN LITTELFUSE INSPECTION INSTRUCTIONS	
CP	DENOTES CP DIMENSIONS. -MINIMUM CP VALUE MUST BE WITHIN THE DIMENSIONAL LIMITATIONS SHOWN ON DRAWING AND INITIALLY LOCATED TO ALLOW FOR MAXIMUM TOOL LIFE	
NAME	DATE	
DRAWN	JY. SHI	MAY./15/2025
CHECKED	V. ZHANG	MAY./16/2025
FORM NO. CVP-PE40-0005 REV B		
THIRD ANGLE PROJECTION		
DO NOT SCALE DRAWING	SCALE 1:1	SHEET 1 OF 1



TITLE DCNHE NON-POLAR CONTACTOR WITH AUXILIARY CONTACT

SIZE C DWG. NO. OUTLINE OL-DCNHE250MFX-F, CHT REV. A