

REVISIONS				
ZONE	REV.	DESCRIPTION	DATE	APPROVED
	A	PCO: 5301405, INITIAL RELEASE	08/15/2025	D. ZHANG

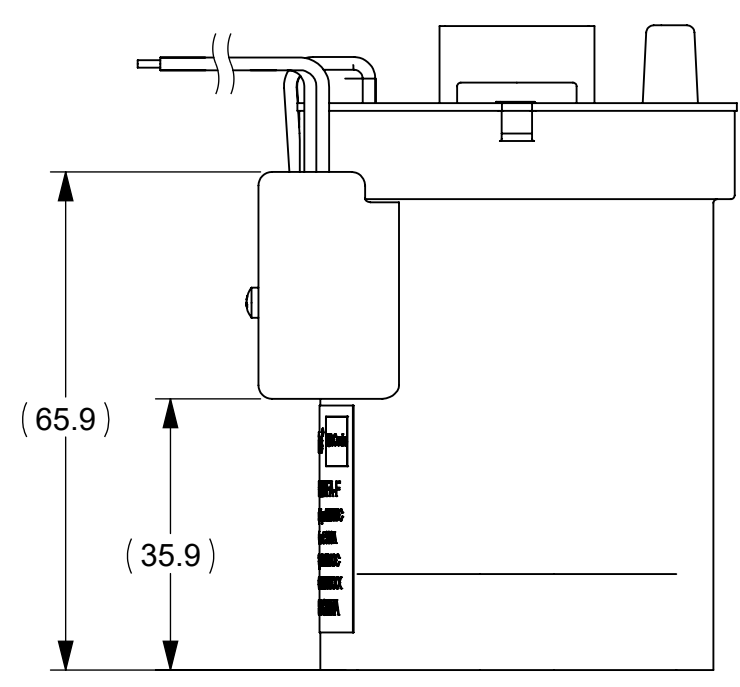

- NOTES:
- ALL SIZES ARE FOR REFERENCE ONLY.
  - MATERIALS AND FINISHED:
    - HOUSING: THERMOPLASTIC, UL94-V0.
    - CONTACTS: COPPER ALLOY.
  - PRODUCT TECHNICAL PARAMETERS: SEE TABLE 1.
  - MAIN CONTACT ARRANGEMENT: SPST-NO, NON-POLAR.
  - CERTIFICATIONS: CE.
  - RoHS AND REACH COMPLIANT.
  - APPROX WEIGHT 650g.

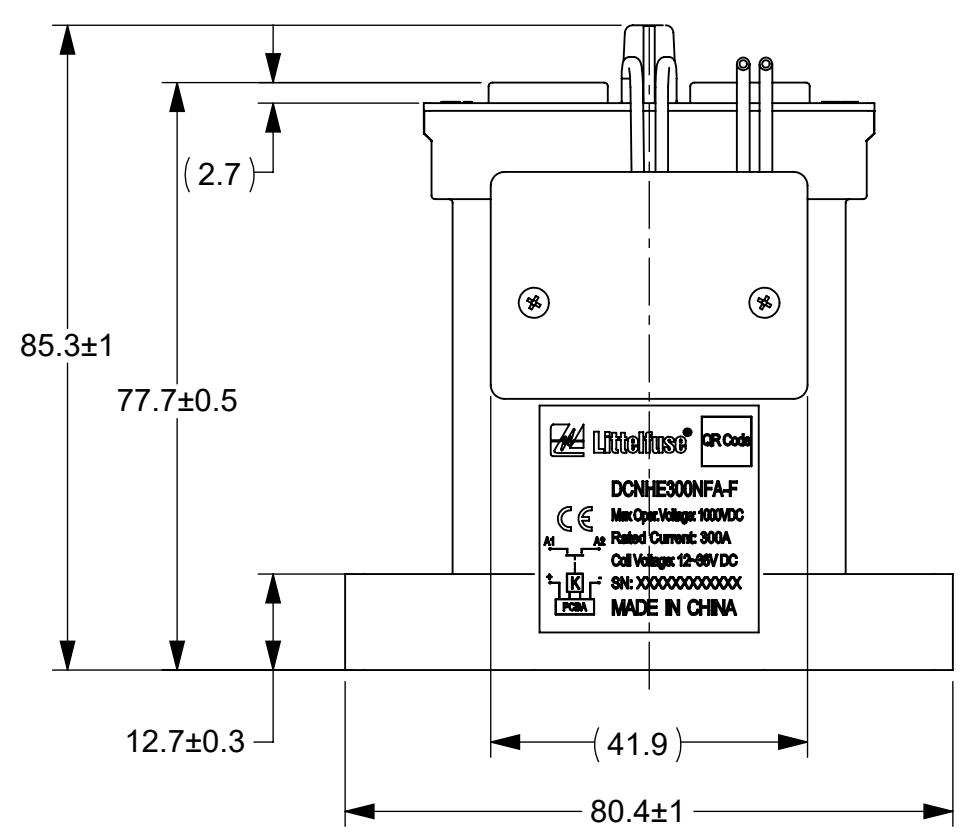
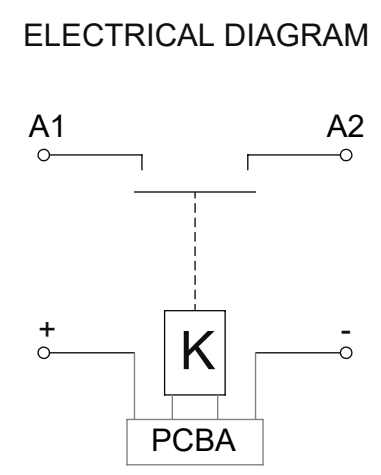
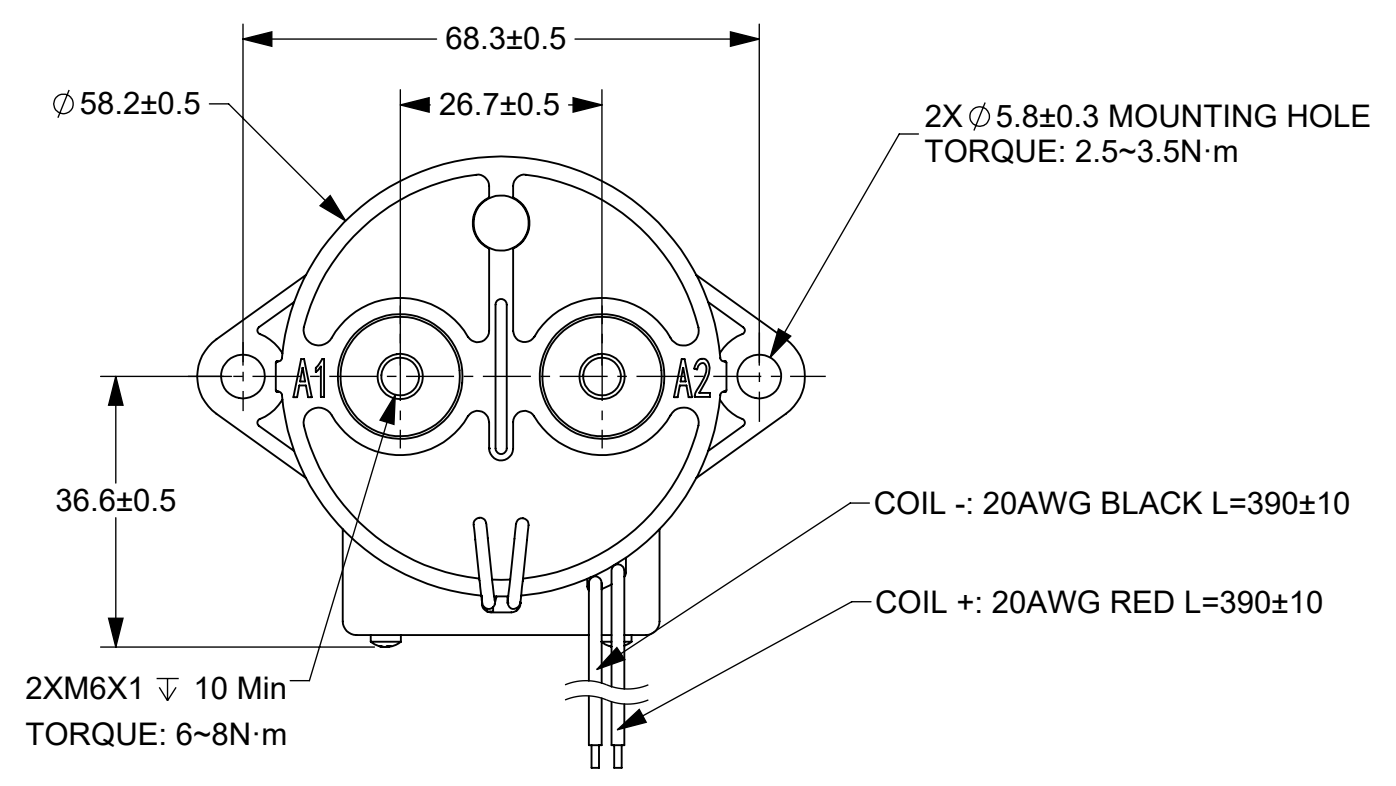
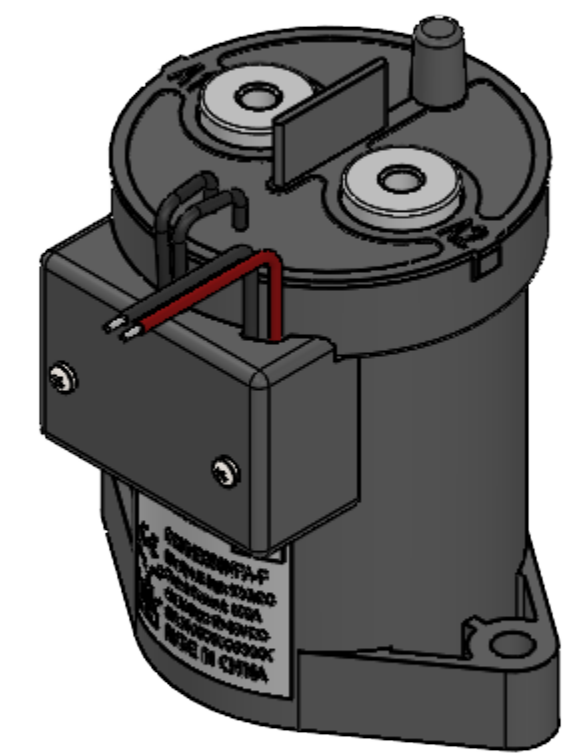

TABLE 1: ENGINEERING DESIGN DATA

ITEM		DATA
RATED COIL VOLTAGE		12~36 VDC
STARTING POWER(25°C)		MAX 50W
HOLDING POWER(25°C)		4W
OPERATING VOLTAGE IN COLD STATE AT 25°C	OPERATE	8~9 VDC
	RELEASE	5.5~7 VDC
OPERATE TIME		MAX 35ms
RELEASE TIME		MAX 10ms
MAIN CONTACT VOLTAGE DROP		120mV@300A
DIELECTRIC STRENGTH (LEAKAGE CURRENT ≤1 mA)		BETWEEN THE CONTACT AND CONTACT: 4000V AC, 50Hz/60Hz, 1min. BETWEEN THE CONTACT AND COIL: 2200V AC, 50Hz/60Hz, 1min.
INSULATION RESISTANCE		100MΩ@1000 VDC
CONTACT VOLTAGE RANGE		12 VDC~1000 VDC
CONTACT CONTINUE CURRENT		300A(500A WITH 400MCM CABLE)
OPERATING TEMP		-40°C ~ +85°C
MAX. BREAKING CURRENT		2500A@320VDC, 1CYCLE
ELECTRICAL LIFE (RESISTIVE LOAD)		1000 CYCLES (150A @ 1000V DC); 3000 CYCLES (300A @ 450V DC)
MECHANICAL LIFE		300, 000 CYCLES

PER CHNFPD20-008 PROCEDURE

● FIT/ FUNCTION CRITICAL CHARACTERISTICS

<S> SAFETY/ COMPLIANCE CRITICAL CHARACTERISTICS SYMBOL

CPK DENOTES CPK DIMENSIONS MINIMUM CPK VALUE

(ST) DENOTES A CHARACTERISTIC THAT PROVIDES AN INDICATION OF PROCESS PERFORMANCE PROCEDURE FOR MEASUREMENT AND TRACKING TO BE DEFINED IN LITTELFUSE INSPECTION INSTRUCTIONS

CP DENOTES CP DIMENSIONS. MINIMUM CP VALUE MUST BE WITHIN THE DIMENSIONAL LIMITATIONS SHOWN ON DRAWING AND INITIALLY LOCATED TO ALLOW FOR MAXIMUM TOOL LIFE

NAME	DATE
MJ. DAI	08/16/2025
CHECKED	D. ZHANG 08/16/2025

FORM NO. CVP-PE40-0005 REV B

THIRD ANGLE PROJECTION

**Littelfuse**  
Expertise Applied | Answers Delivered

TITLE: DC CONTACTOR 300A

SIZE: C DWG. NO.: OL-DCNHE300NFA-F REV. A

DO NOT SCALE DRAWING SCALE 1:1 SHEET 1 OF 1