

REVISIONS				
ZONE	REV.	DESCRIPTION	DATE	APPROVED
	A	PCO: 5301395, INITIAL RELEASE	08/15/2025	D. ZHANG

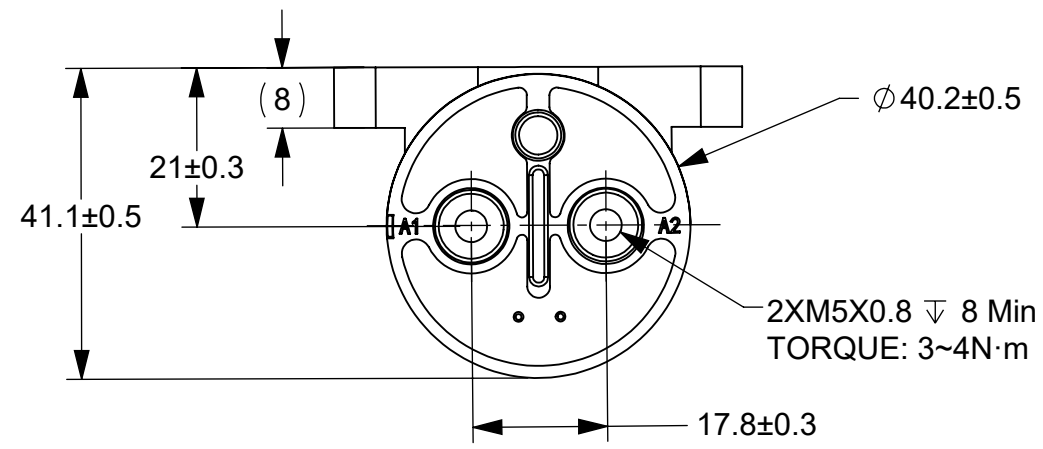

ELECTRICAL DIAGRAM

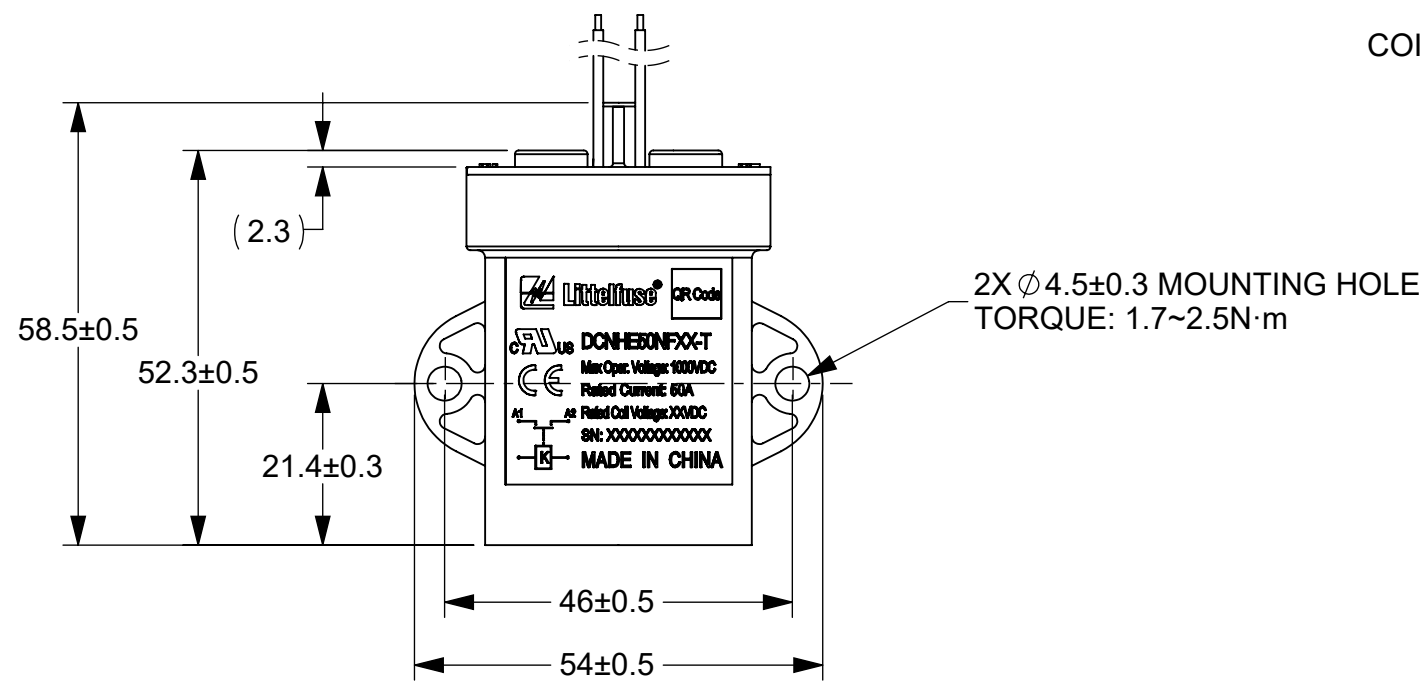
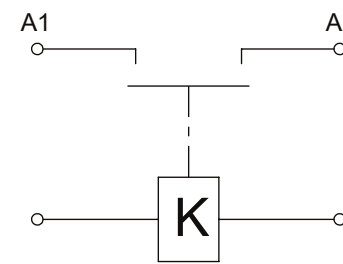

COIL WIRE: 22AWG WHITE

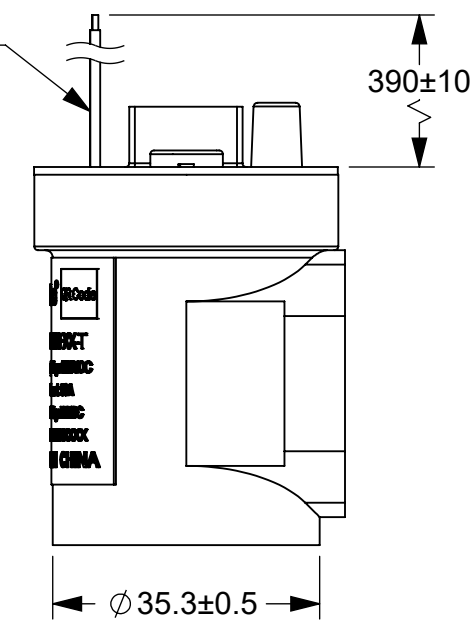
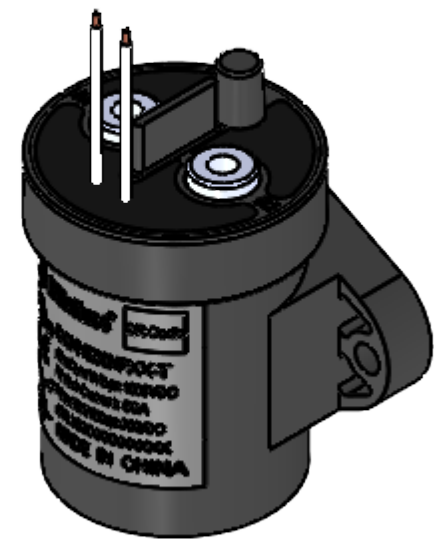

TABLE 1: ENGINEERING DESIGN DATA

ITEM	DATA		
	DCNHE50NF12-T	DCNHE50NF24-T	DCNHE50NF48-T
RATED COIL VOLTAGE	12 VDC	24 VDC	48 VDC
HOLDING CURRENT(25°C)	MAX 0.6A	MAX 0.3A	MAX 0.16A
HOLDING POWER(25°C)	5W ~ 7W	5W ~ 7W	5W ~ 7W
OPERATING VOLTAGE IN COLD STATE AT 25°C	OPERATE	MAX 9 VDC	MAX 18 VDC
	RELEASE	MIN 1 VDC	MIN 2 VDC
OPERATE TIME	MAX 30ms		
RELEASE TIME	MAX 10ms		
MAIN CONTACT VOLTAGE DROP	60mV@50A		
DIELECTRIC STRENGTH (LEAKAGE CURRENT ≤1 mA)	BETWEEN THE CONTACT AND CONTACT: 4000V AC, 50Hz/60Hz,1min. BETWEEN THE CONTACT AND COIL: 2200V AC, 50Hz/60Hz,1min.		
INSULATION RESISTANCE	100MΩ@1000 VDC		
CONTACT VOLTAGE RANGE	12 VDC~1000 VDC		
RATED CONTACT CURRENT	50A		
OPERATING TEMP	-40°C ~ +85°C		
MAX. BREAKING CURRENT	1000A@320VDC, 1CYCLE		
ELECTRICAL LIFE (RESISTIVE LOAD)	6000 CYCLES (50A @ 450V DC); 1000 CYCLES (50A @ 750V DC); 1000 CYCLES (20A @ 1000V DC)		
MECHANICAL LIFE	300,000 CYCLES		

NOTES:

- ALL SIZES ARE FOR REFERENCE ONLY.
- MATERIALS AND FINISHED:
  - HOUSING: THERMOPLASTIC, UL94V-0.
  - CONTACTS: COPPER ALLOY.
- PRODUCT TECHNICAL PARAMETERS: SEE TABLE 1.
- MAIN CONTACT ARRANGEMENT: SPST-NO, NON-POLAR.
- CERTIFICATIONS: UL, CE.
- RoHS AND REACH COMPLIANT.
- APPROX WEIGHT 200g.



DIMENSIONS ARE SHOWN IN MILLIMETERS. DIMENSIONS AND TOLERANCES ARE DEFINED ACCORDING TO ANSIA/SME Y14.5-1994.		FIT/ FUNCTION CRITICAL CHARACTERISTICS	
<S>	SAFETY/ COMPLIANCE CRITICAL CHARACTERISTICS SYMBOL		
CPK	DENOTES CPK DIMENSIONS MINIMUM CPK VALUE		
(ST)	DENOTES A CHARACTERISTIC THAT PROVIDES AN INDICATION OF PROCESS PERFORMANCE PROCEDURE FOR MEASUREMENT AND TRACKING TO BE DEFINED IN LITTELFUSE INSPECTION INSTRUCTIONS		
CP	DENOTES CP DIMENSIONS. MINIMUM CP VALUE MUST BE WITHIN THE DIMENSIONAL LIMITATIONS SHOWN ON DRAWING AND INITIALLY LOCATED TO ALLOW FOR MAXIMUM TOOL LIFE		
NAME	DATE	Littelfuse Expertise Applied   Answers Delivered	
DRAWN MJ. DAI	08/16/2025	TITLE DC CONTACTOR 50A	
CHECKED D. ZHANG	08/16/2025	THIRD ANGLE PROJECTION	
FORM NO. CVP-PE40-0005 REV B	SIZE C DWG. NO. OUTLINE OL-DCNHE50NFXX-T.CHART REV. A		
DO NOT SCALE DRAWING	SCALE 1:1	SHEET 1 OF 1	