

REVISIONS				
ZONE	REV.	DESCRIPTION	DATE	APPROVED
	A	PCO-50000301403 INITIAL RELEASE	MAY./28/2025	D. ZHANG

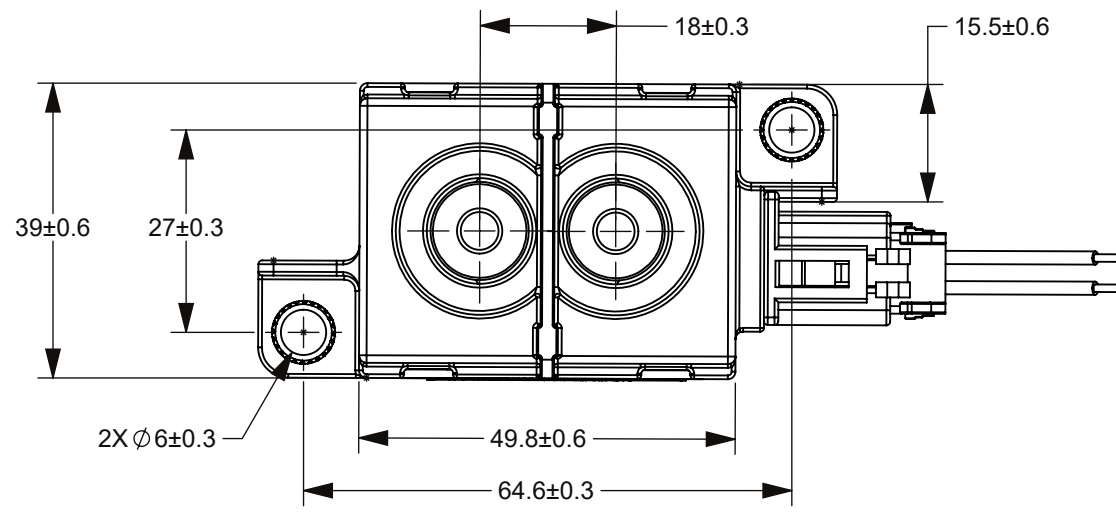

CIRCUIT SCHEMATIC DIAGRAM

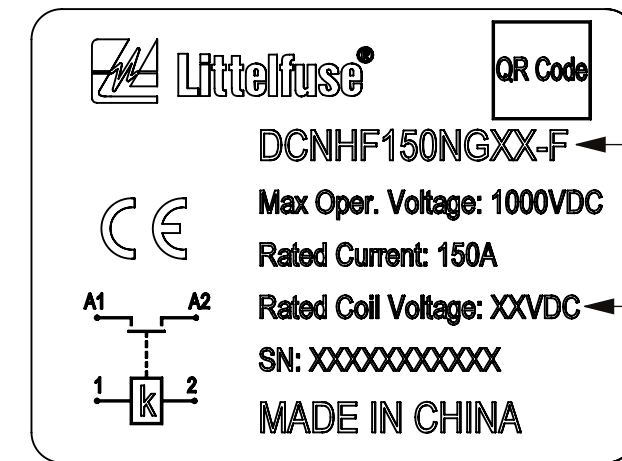
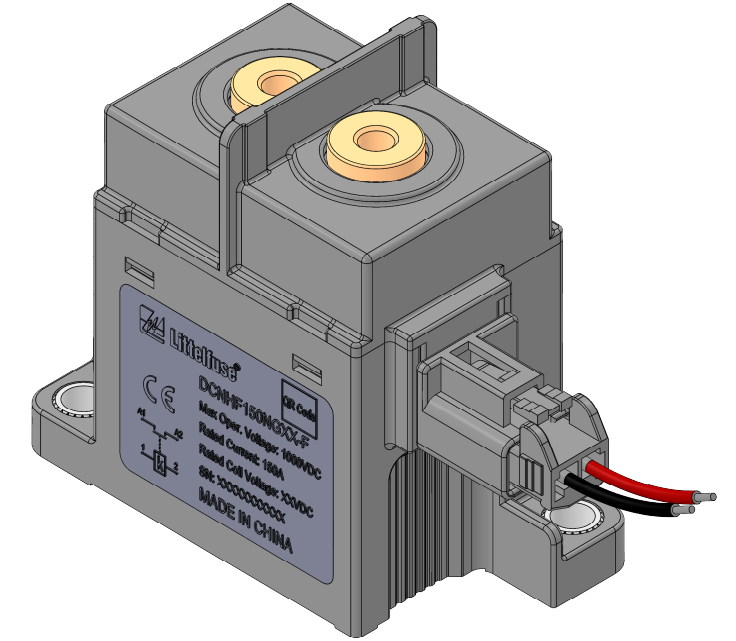
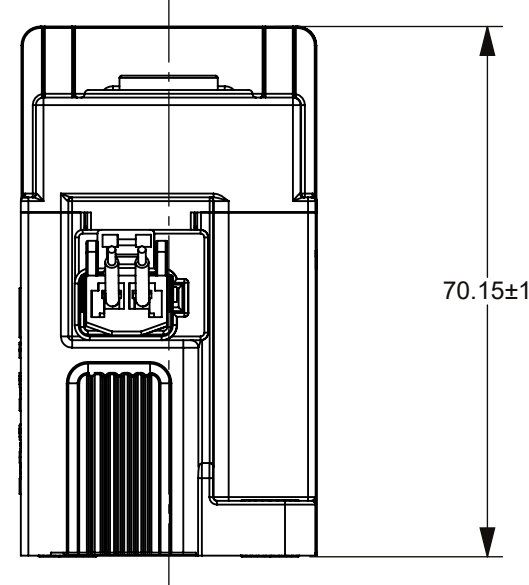
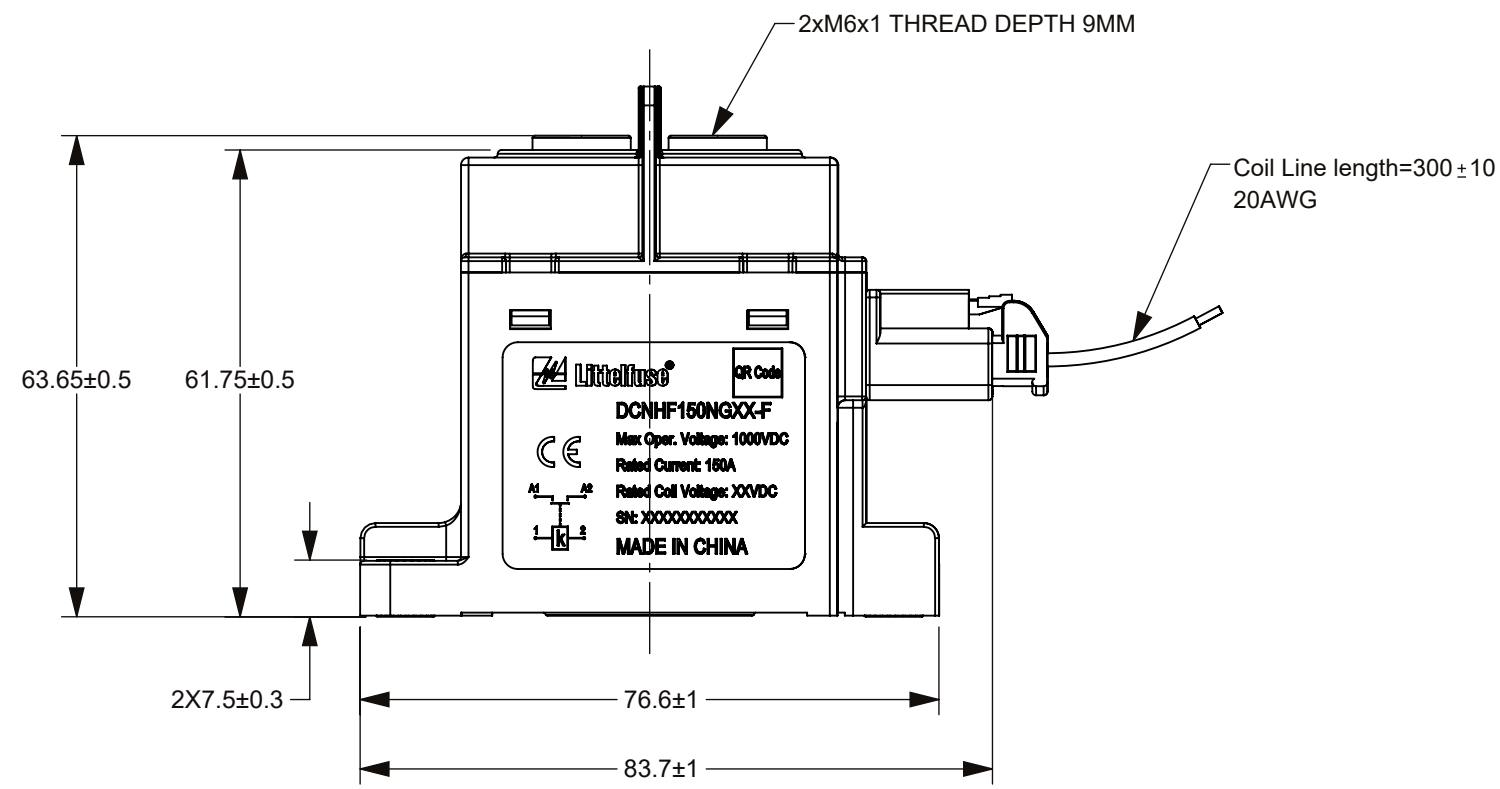
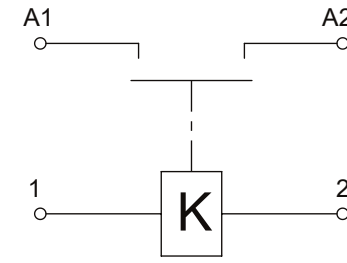

VIEW 1  
SCALE 2:1

TABLE 1

PART NUMBER		DCNH150NG12-F	DCNH150NG24-F
Max. SWITCHING VOLTAGE		1,000V DC	
RATED CONTACT CURRENT		150A	
OPERATING VOLTAGE IN COLD STATE @ 25°C	COIL VOLTAGE	12V DC	24V DC
	MAX. VOLTAGE	16V DC	32V DC
	COIL POWER	6.5W	
	PICK-UP	≤9V	≤18V
DROP-OUT		≥1V	≥2V
MAIN CONTACT VOLTAGE DROP		≤80mV@150A	
INSULATION RESISTANCE @ 1,000 VDC (INITIAL)		≥1,000MΩ	
DIELECTRIC STRENGTH	Between open contacts	3,000V AC, 1 MINUTE, LEAKAGE CURRENT≤1 mA	
	Between contacts and coil	4,000V AC, 1 MINUTE, LEAKAGE CURRENT≤1 mA	
MAX BREAK CAPABILITY		2000A@450V DC, 1CYCLE	
ELECTRIC LIFE (RESISTIVE LOAD)	3000 CYCLES (150A @ 450V DC)		
	500 CYCLES (150A @ 750V DC)		
	300 CYCLES (100A @ 1000V DC)		
MECHANICAL LIFE (NO LOAD, CYCLES)		200,000	

TABLE 2

NO.	"A"	"B"	REMARK
1	DCNH150NG12-F	12VDC	NAMEPLATE(VIEW1)
2	DCNH150NG24-F	24VDC	

NOTES:

- ALL DIMENSIONS ARE REFERENCE ONLY.
- SEE TABLE 2 FOR NAME PLATE AND PNs.
- PRODUCT TYPE: SPST-NO, NON-POLAR CONTACTOR.
- MATERIALS AND FINISH:
  - HOUSING: THERMOPLASTIC PLASTICS.
  - CONTACTS: COPPER ALLOY.
  - CONTACT STUDS: PURE COPPER.
  - WEIGHT: ABOUT 320GRAMS.
- MAIN CONTACT M6 STUD, TORQUE: 8~10N·m.
- MOUNTING: M5 BOLT, RECOMMENDED TORQUE 3 N·m ~ 4 N·m.
- RoHS COMPLIANT.

DIMENSIONS ARE SHOWN IN MILLIMETERS. DIMENSIONS AND TOLERANCES ARE DEFINED ACCORDING TO ANSIA/SME Y14.5-1994.	
●	FTI/ FUNCTION CRITICAL CHARACTERISTICS
<S>	SAFETY/ COMPLIANCE CRITICAL CHARACTERISTICS SYMBOL
CPK	DENOTES CPK DIMENSIONS MINIMUM CPK VALUE
(ST)	DENOTES A CHARACTERISTIC THAT PROVIDES AN INDICATION OF PROCESS PERFORMANCE PROCEDURE FOR MEASUREMENT AND TRACKING TO BE DEFINED IN LITTELFUSE INSPECTION INSTRUCTIONS
CP	DENOTES CP DIMENSIONS. MINIMUM CP VALUE MUST BE WITHIN THE DIMENSIONAL LIMITATIONS SHOWN ON DRAWING AND INITIALLY LOCATED TO ALLOW FOR MAXIMUM TOOL LIFE
NAME	DATE
DRAWN V. ZHANG	MAY./28/2025
CHECKED JY. SHI	MAY./28/2025
FORM NO. CVP-PE40-0005 REV B	
THIRD ANGLE PROJECTION	
SIZE C	DWG. NO. OL-DCNH150NGXX-F,CHT
DO NOT SCALE DRAWING	SCALE 1:1
Expertise Applied   Answers Delivered	
TITLE DCNH150 150A NON-POLAR CONTACTOR	
REV. A	SHEET 1 OF 1