

DCNHF300 Series

1000V DC Max Contactor Relays



Description

The DCNHF300 Series high-voltage DC contactor relay is engineered for demanding electric vehicle and industrial high-power DC applications that require robust, reliable switching at high current levels. Rated for 300A continuous current and up to 1000V DC, it is ideal for use in battery power supply systems, charging infrastructure, motor control, circuit isolation, circuit protection, and industrial safety systems.

Featuring SPST normally open (NO) circuitry with non-polarized contacts, the DCNHF300 Series contactor supports bidirectional current flow, providing flexibility across a wide range of electrical systems. Its bottom-mounting design enables secure installation, while the rugged construction is optimized for performance in harsh automotive and industrial environments.

The DCNHF300 Series contactor is equipped with internal-thread terminals to ensure secure high-current connections. It is available with 12V DC or 24V DC coil voltage options, supporting common EV and industrial control system requirements.

Web Resources

Download 2D print, installation guide and technical resources at: [littelfuse.com/DCNHF300](https://www.littelfuse.com/DCNHF300)

Ordering Information

PART NUMBER	RATED CURRENT(A)	POLARIZED	AUX. CONTACT	COIL VOLTAGE(V DC)	MOUNTING	POWER CONNECTION
DCNHF300NG12-F	300	No	No	12	Bottom	Internal Thread
DCNHF300NG24-F	300	No	No	24	Bottom	Internal Thread

Specifications

Rating Continuous Current	300A
Contact Max. Voltage	1000V DC
Contact Circuitry	SPST NO
Ingress Protection	Contact IP67
Contacts Material	Copper Alloy
Terminals	M6 Copper
Contact Torque	M6 Bolt: 6~8N·m
Housing	Nylon UL 94-V0
Coil Connector	Yazaki 7283-1020 (compatible option)
Coil Type	Single
Mounting Method	M5 Bolt
Mounting Torque	M5 Bolt: 3~4N·m
Normal Position	Any Mounting Position
Approvals:	
CE:	EN 60947-4-1,2018

Applications

- Battery Electric Vehicles
- Hybrid Electric Vehicles
- Material Handling
- Electric Maintenance and Transport Vehicles
- Industrial Applications

Features and Benefits

- High voltage (1000V) contactor for EV applications
- Compact structure, helping reduce noise when turned on
- Resin housing provides corrosion resistance in harsh automotive environments
- Sealed contacts with no leakage of electrical arc for maximum safety
- No mounting orientation restrictions
- RoHS and REACH compliant

DCNHF300 Series

1000V DC Max Contactor Relays

Performance Data

MAIN CONTACT	
Contact Arrangement	1 Form, SPST-NO
Operating Voltage	12-1000V DC
Continuous Current	300A
Max Short Circuit	1000A, 0.6s
Max Breaking Limit	2000A@750V DC, 1cycle
Dielectric Withstanding Voltage	Between open contacts: 3000V AC, ≤1mA,1min Between contact and coil: 4000V AC, ≤1mA,1min
Insulation Resistance	Min. 1000 MΩ@1000V DC
Contact Voltage Drop	≤150mV@300A

COIL DATA		
Rating Voltage	12V DC	24V DC
Voltage (Max.)	16V DC	32V DC
Pickup Voltage (25°C)	≤9V DC	≤18V DC
Release Voltage (25°C)	≥1V DC	≥2V DC
Rating Current (25°C)	≤0.5A	≤0.25A
Rating Power (25°C)	6.5W	6.5W

Note: The coil of the product may operate at maximum voltage for a maximum duration of 30 minutes.

LIFE	
Electrical Life (Resistive)	1000 cycles, 300A@450V DC 500 cycles, 300A@750V DC 100 cycles, 300A@1000V DC
Mechanical Life	200,000 cycles

Note: Electrical life rating is based on resistive load with 27μH maximum inductance in circuit. Because your application may be different, we suggest you test the contactor in your circuit to verify life is as required.

OPERATE / RELEASE TIME	
Pickup Time(includes bounce)	≤30ms
Release Time	≤10ms

ENVIRONMENTAL DATA	
Shock, 11ms ½ Sine, Operating	20g, Peak
Vibration, Sine	10-500Hz, 5g, Peak
Operating Temperature	-40°C~+85°C
Humidity	5%-85%RH
Weight	380g

Carry Current vs Time Chart at 65°C Chart

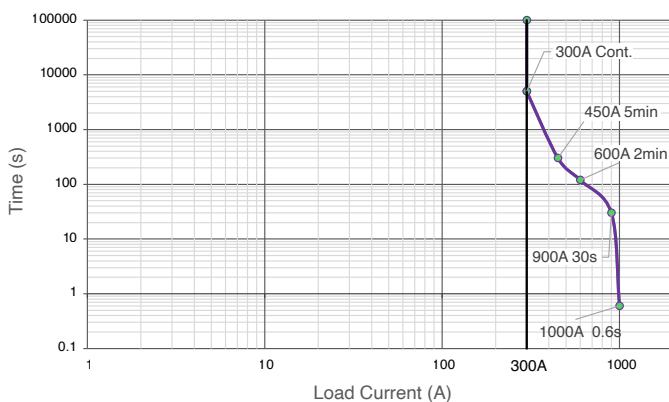

Electrical Diagrams

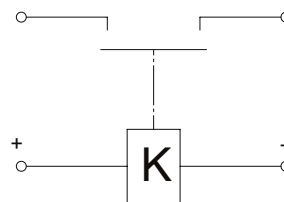

DCNHF300 Series

1000V DC Max Contactor Relays

Part Number System

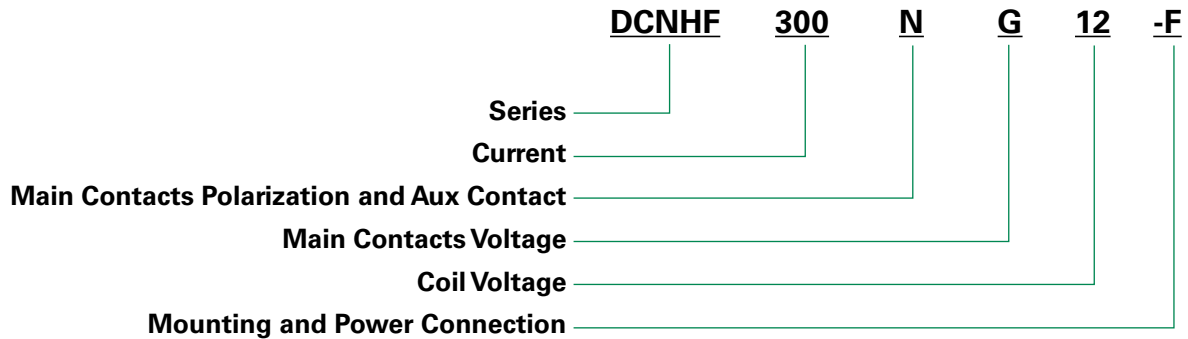

MAIN CONTACTS POLARIZATION AND AUX CONTACT		
	POLARIZED?	INCLUDE AUX CONTACT?
N:	No	No

MAIN CONTACT TEST VOLTAGE		
G:	750	V DC

COIL VOLTAGE		
12:	12	V DC
24:	24	V DC

MOUNTING		POWER CONNECTION
F:	Bottom	Internal Thread

- Be sure to use washer to prevent screws from loosening, all the terminals or copper bar must be in direct contact with the contactor's terminals. Screw tightening torque is specified below. Exceeding the maximum torque can lead to product failure.
 - Contact torque: in (6 ~8) N.m.
 - Mounting torque: in (3~4) N.m.
- The contact terminals are non-polarized and the coil wires are polarized. For correct wiring, please refer to the provided schematic diagram.
- Do not use if dropped.
- Avoid installing in a strong magnetic field (close to a transformer or magnet), or near a heat source.
- Electrical life

Use per load capability and life cycle limits so as not to cause a function failure (treat the contactor as a product with specified life and replace it when necessary). It is possible to make parts burn around the contactor once operating failure occurs. It is necessary to take layout into account and to make sure power shall be cut off within 1 second.

- Lifetime of internal gas diffusion

The contactor is sealed and filled with gas, lifetime of gas diffusion is determined by temperature in contact chamber (ambient temperature + temperature generated by contact operation). Operate only in an ambient temperature from -40°C to +85°C.
- Drive power must be greater than coil power or it will reduce performance capability.
- Avoid debris or oil contamination on the main terminals to optimize contact and avoid excess heat generation.
- Applications with capacitors will require a pre-charge circuit.