

DCNHF500 Series

1800V DC Max Contactor Relays



Description

The DCNHF500 Series high-voltage DC contactor has a 500A continuous current rating and a maximum contact voltage of 1800V. The dependable contactor is designed for use in electric vehicle (EV) and industrial applications, such as battery power supply, charging systems, motor control, circuit insulation, circuit protection, and safety-critical systems.

Featuring non-polarized, sealed contacts and a double-coil design, this industrial and EV contactor supports flexible operation in electrical systems regardless of polarity and can be mounted in any orientation. Its double-coil economizer minimizes power consumption once the contactor is engaged, reducing heat generation and improving overall efficiency and reliability.

The DCNHF500 Series contactor also includes an auxiliary contact and is available in 12V or 24V polarized coil configurations with internal thread terminals.

Web Resources

Download 2D print, installation guide and technical resources at: littelfuse.com/DCNHF500

Ordering Information

PART NUMBER	RATED CURRENT(A)	POLARIZED	AUX. CONTACT	COIL VOLTAGE(VDC)	MOUNTING	POWER CONNECTION
DCNHF500MH12-F	500	No	Yes	12	Bottom	Internal Thread
DCNHF500MH24-F	500	No	Yes	24	Bottom	Internal Thread

Specifications

Rating Continuous Current:	500A
Contact Max. Voltage:	1800V DC
Rated Voltage:	1500V
Contact Circuitry:	SPST NO
Ingress Protection:	Contact IP67
Contacts Material:	Copper Alloy
Terminals:	M8 Copper
Contact Torque:	M8 Bolt: 12~15N·m
Housing:	Nylon UL 94 V-0
Coil Connector:	Yazaki 7283-1044 (compatible option)
Coil Type:	Double
Mounting Method:	M5 Bolt
Mounting Torque:	M5 Bolt: 3~4N·m
Normal Position:	Any Mounting Position
Approvals:	
UL File Number:	E47258 Recognized
CE:	EN 60947-4-1,2018

Applications

- Battery Electric Vehicles
- Hybrid Electric Vehicles
- Material Handling
- Electric Maintenance and Transport Vehicles
- Industrial Applications
- Energy Storage Applications

Features and Benefits

- High voltage (1800V) contactor for EV applications
- Resin housing provides corrosion resistance in harsh automotive environments
- Sealed contacts with no leakage of electrical arc for maximum safety
- No mounting orientation restrictions
- Ceramic arc chamber enables higher contact voltage capability
- RoHS and REACH compliant

DCNHF500 Series

1800V DC Max Contactor Relays

Performance Data

MAIN CONTACT	
Contact Arrangement	1 Form, SPST-NO
Operating Voltage	6-1800VDC
Continous Current	500A
Max Short Circuit	8000A, 5ms
Max Breaking Limit	2000A@1000VDC, 1cycle, 1000A@1500VDC, 1cycle
Dielectric Withstanding Voltage	Between open contacts: 4000VAC, ≤1mA,1min Between contact and coil: 4000VAC, ≤1mA,1min
Insulation Resistance	Min. 1000 MΩ@1000VDC
Contact Voltage Drop	≤0.2mΩ@500A

COIL DATA		
Rating Voltage	12VDC	24VDC
Voltage (Max.)	16VDC	32VDC
Pickup Voltage (25°C)	≤8VDC	≤16VDC
Release Voltage (25°C)	≥1.2VDC	≥2.4VDC
Starting Current (25°C)	≤4.2A	≤2.1A
Starting Power (25°C)	50W	50W
Holding Current (25°C)	≤0.42A	≤0.21A
Holding Power (25°C)	5W	5W

Note: This product is a double-coil, and the coil control voltage must be a step voltage. A slowly rising voltage can not make the contactor work.

Carry Current vs Time at 65°C Chart

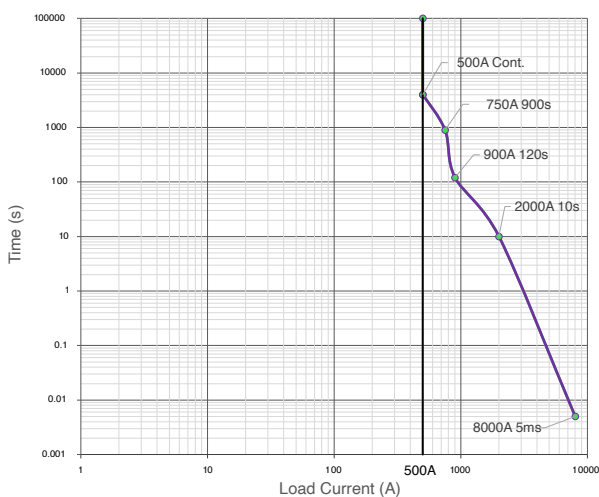

LIFE	
Electrical Life (Resistive)	1500 Cycles, Only Break 500A @ 1,000V DC 20 Cycles, Only Break 500A @ 1,500V DC 6000 Cycles, 100A @ 1,800V DC
Mechanical Life	200,000 cycles

Note: Electrical life rating is based on resistive load with 27μH maximum inductance in circuit. Because your application may be different, we suggest you test the contactor in your circuit to verify life is as required.

OPERATE / RELEASE TIME	
Pickup Time (includes bounce)	≤50ms
Release Time	≤30ms

ENVIRONMENTAL DATA	
Shock, 11ms ½ Sine, Operating	20g, Peak
Vibration, Sine	55-2000Hz, 5g, Peak
Operating Temperature	-40°C~+85°C
Humidity	5%-85%RH
Weight	1100g

AUX. CONTACT	
Aux. Contact Arrangement	1 Form A
Aux. Contact Current Max.	2A@24VDC
Aux. Contact Current Min.	5mA@12VDC
Max. Contact Resistance	300mΩ

Electrical Diagram

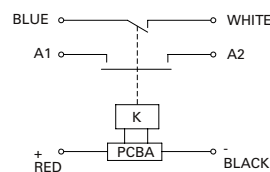

DCNHF500 Series

1800V DC Max Contactor Relays

Part Number System

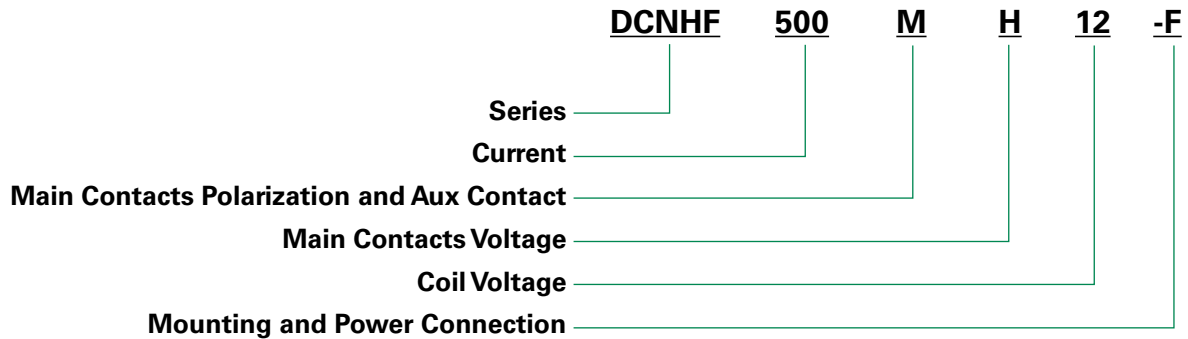

MAIN CONTACTS POLARIZATION AND AUX CONTACT		
	POLARIZED?	INCLUDE AUX CONTACT?
M:	No	Yes

MAIN CONTACT TEST VOLTAGE		
H:	1000	V DC

COIL VOLTAGE		
12:	12	V DC
24:	24	V DC

MOUNTING		POWER CONNECTION
F:	Bottom	Internal Thread

- Be sure to use washer to prevent screws from loosening, all the terminals or copper bar must be in direct contact with the contactor's terminals. Screw tightening torque is specified below. Exceeding the maximum torque can lead to product failure.
 - Contact torque: in (12~15) N.m.
 - Mounting torque: in (3~4) N.m.
- Contact terminals are non-polarized, Coil terminals are polarized, so refer to drawing during connecting. We suggest using a varistor rather than diode as a surge protector.
- Do not use if dropped.
- Avoid installing in a strong magnetic field (close to a transformer or magnet), or near a heat source.
- Electrical life

Use per load capability and life cycle limits so as not to cause a function failure (treat the contactor as a product with specified life and replace it when necessary). It is possible to make parts burn around the contactor once operating failure occurs. It is necessary to take layout into account and to make sure power shall be cut off within 1 second.

- Lifetime of internal gas diffusion

The contactor is sealed and filled with gas, lifetime of gas diffusion is determined by temperature in contact chamber (ambient temperature + temperature generated by contact operation). Operate only in an ambient temperature from -40°C to +85°C.
- Drive power must be greater than coil power or it will reduce performance capability.
- Avoid debris or oil contamination on the main terminals to optimize contact and avoid excess heat generation.
- Applications with capacitors will require a pre-charge circuit.