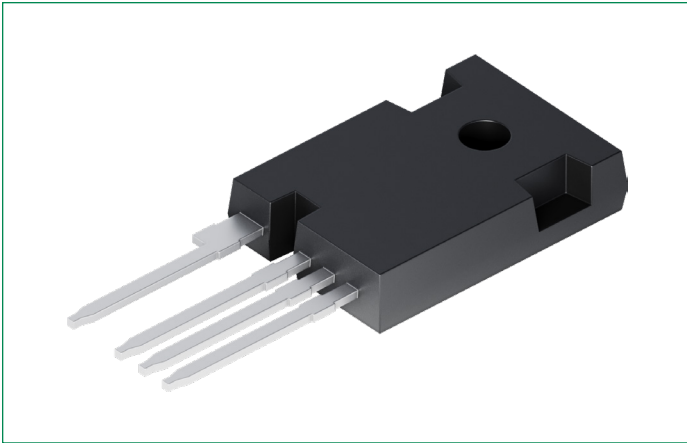

IXSH50N120L3KHV

1200 V, 55 mΩ, 48.3 A SiC MOSFET

HF 

Features

- 3rd Generation SiC MOSFET Technology with -3.5/+15...18 V gate drive
- High blocking voltage with low on-state resistance
- High-speed switching with low capacitance
- 175 °C operating junction temperature capability
- Ultra-fast and robust intrinsic body diode
- Kelvin source contact

Applications

- Motor drives
- EV charging infrastructure
- DC/DC converter
- Switch mode power supplies
- Solar inverters

Product Summary

Characteristic	Value	Unit
V_{DSS}	1200	V
$R_{DS(on)}$	55	mΩ
$I_D @ 25\text{ °C}$	48.3	A

Pinout Diagram (TO-247-4L)

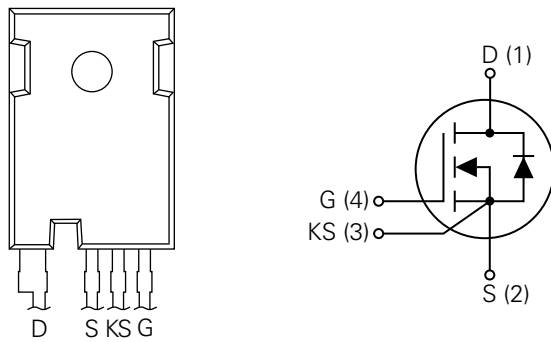

D: Drain; **G:** Gate; **KS:** Kelvin Source; **S:** Source

Maximum Ratings ($T_c = 25\text{ °C}$ unless otherwise specified)

Symbol	Characteristic	Conditions	Value	Unit
V_{DSS}	Drain-source voltage	$V_{GS} = 0\text{ V}, I_D = 100\text{ }\mu\text{A}$	1200	V
V_{GSM}	Maximum gate-source voltage	Static (DC)	-5 to +20	V
	Transient gate-source voltage	Pulse width < 200 ns, D < 1%	-10 to +23	
I_D	Drain current (continuous) Fig. 23	$V_{GS} = 18\text{ V}, T_c = 25\text{ °C}$	48.3	A
		$V_{GS} = 18\text{ V}, T_c = 100\text{ °C}$	34.5	A
I_{DM}	Peak drain current Fig. 26	Pulse width limited by SOA	120.8	A
I_{SM}	Diode pulsed forward current Fig. 25, 26	Pulse width limited by SOA and dynamic $R_{th(j-c)}$	111	A
P_{tot}	Total power dissipation Fig. 24	$T_c = 25\text{ °C}$	250	W
T_{vj}	Virtual junction temperature range	-	-55 to +175	°C
T_{stg}	Storage temperature range	-	-55 to +175	°C
T_{sold}	Soldering temperature	Wave soldering only allowed at leads, 1.6 mm from case for 10 s	260	°C

Recommended Values

Symbol	Characteristic	Value			Unit
		Min.	Typ.	Max.	
V_{GSon}	Recommended turn-on voltage	15	-	18	V
V_{GSoff}	Recommended turn-off voltage	-3.5	-	-2	

Thermal Characteristics

Symbol	Characteristic	Value			Unit
		Min.	Typ.	Max.	
$R_{th(j-c)}$	Thermal resistance from junction to case Fig. 25	-	0.6	-	K/W

Electrical Characteristics – Static ($T_c = 25\text{ °C}$ unless otherwise specified)

Symbol	Characteristic	Conditions	Value			Unit
			Min.	Typ.	Max.	
I_{DSS}	Drain-source leakage current	$V_{DS} = 1200\text{ V}, V_{GS} = 0\text{ V}$	-	5	100	μA
I_{GSS}	Gate leakage current	$V_{DS} = 0\text{ V}, V_{GS} = -5 \sim 20\text{ V}$	-	-	± 100	nA
$V_{GS(th)}$	Gate threshold voltage Fig. 8, 9	$V_{GS} = V_{DS}, I_D = 4\text{ mA}$	2.0	2.8	4.0	V
		$V_{GS} = V_{DS}, I_D = 4\text{ mA}, T_{vj} = 175\text{ °C}$	-	2.0	-	
$R_{DS(on)}$	Drain-source on-state resistance Fig. 4, 5, 6, 7	$V_{GS} = 18\text{ V}, I_D = 14\text{ A @ } T_{vj} = 25\text{ °C}$	-	55	71	m Ω
		$V_{GS} = 18\text{ V}, I_D = 14\text{ A @ } T_{vj} = 175\text{ °C}$	-	93	-	
		$V_{GS} = 15\text{ V}, I_D = 14\text{ A @ } T_{vj} = 25\text{ °C}$	-	66	-	
		$V_{GS} = 15\text{ V}, I_D = 14\text{ A @ } T_{vj} = 175\text{ °C}$	-	98	-	

Electrical Characteristics – Dynamic ($T_{vj} = 25\text{ °C}$ unless otherwise specified)

Symbol	Characteristic	Conditions	Value			Unit	
			Min.	Typ.	Max.		
C_{iss}	Input capacitance Fig. 16	$V_{DS} = 800\text{ V}, V_{GS} = 0\text{ V},$ $f = 100\text{ kHz}, V_{AC} = 25\text{ mV}$	–	1340	–	pF	
C_{oss}	Output capacitance Fig. 16		–	61.7	–		
C_{rss}	Reverse transfer capacitance Fig. 16		–	1.75	–		
E_{oss}	C_{oss} stored energy Fig. 17		–	25.9	–		μJ
Q_G	Total gate charge Fig. 18	$V_{DS} = 800\text{ V}, I_D = 20\text{ A},$ $V_{GS} = -3\text{ to }+18\text{ V}$	–	55.6	–	nC	
Q_{GS}	Gate-source charge Fig. 18		–	14.4	–		
Q_{GD}	Gate-drain charge Fig. 18		–	15.2	–		
$R_{g(int)}$	Gate input resistance	$f = 1\text{ MHz}$	–	4.18	–	Ω	
E_{on}	Turn-on switching energy Fig. 19, 20	$V_{DS} = 800\text{ V}, I_D = 20\text{ A},$ $V_{GS} = -3.5\text{ to }+18\text{ V},$ $R_{G(ext)} = 3.3\ \Omega, L = 200\ \mu\text{H}$	$T_{vj} = 25\text{ °C}$	–	178.3	–	μJ
			$T_{vj} = 175\text{ °C}$	–	270.6	–	
E_{off}	Turn-off switching energy Fig. 19, 20, 22		$T_{vj} = 25\text{ °C}$	–	34	–	ns
			$T_{vj} = 175\text{ °C}$	–	37.2	–	
$t_{d(on)}$	Turn-on delay time Fig. 19, 20		$T_{vj} = 25\text{ °C}$	–	5.2	–	ns
t_r	Rise time Fig. 19, 20		$T_{vj} = 25\text{ °C}$	–	11.8	–	
$t_{d(off)}$	Turn-off delay time Fig. 19, 20		$T_{vj} = 25\text{ °C}$	–	12.5	–	
t_f	Fall time Fig. 19, 20		$T_{vj} = 25\text{ °C}$	–	7.5	–	

Reverse Diode Characteristics ($T_{vj} = 25\text{ °C}$ unless otherwise specified)

Symbol	Characteristic	Conditions	Value			Unit
			Min.	Typ.	Max.	
V_{SD}	Diode forward voltage Fig. 10, 11, 12	$I_{SD} = 7\text{ A}, V_{GS} = 0\text{ V}$	–	3.1	–	V
		$I_{SD} = 7\text{ A}, V_{GS} = 0\text{ V}, T_{vj} = 175\text{ °C}$	–	2.8	–	V
I_s	Diode forward current (continuous)	$V_{GS} = -2\text{ V}, T_c = 25\text{ °C}$	–	–	44.4	A
		$V_{GS} = -2\text{ V}, T_c = 100\text{ °C}$	–	–	26.1	
t_{rr}	Reverse recovery time	$V_{GS} = -3.5\text{ V}/+18\text{ V}, I_{SD} = 20\text{ A}, V_R = 800\text{ V},$ $R_{G(ext)} = 12\ \Omega, L = 200\ \mu\text{H}, di/dt = 3000\text{ A}/\mu\text{s}$	–	19.6	–	ns
Q_{rr}	Reverse recovery charge		–	120	–	nC
I_{rrm}	Peak reverse recovery current		–	16.4	–	A

Characteristic Curves

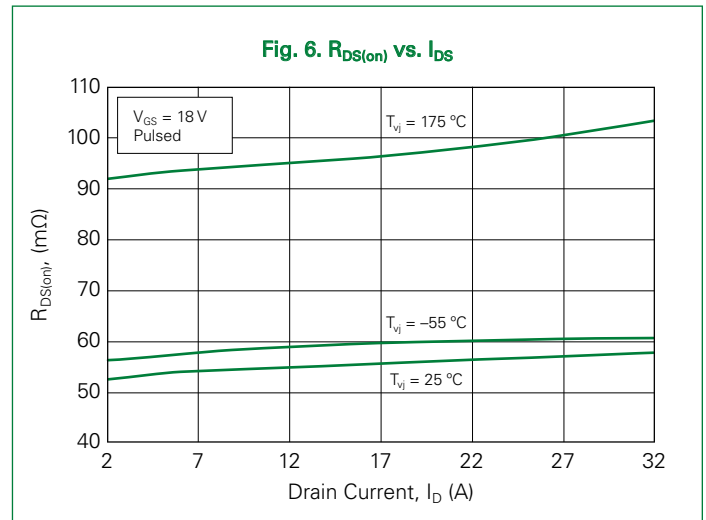
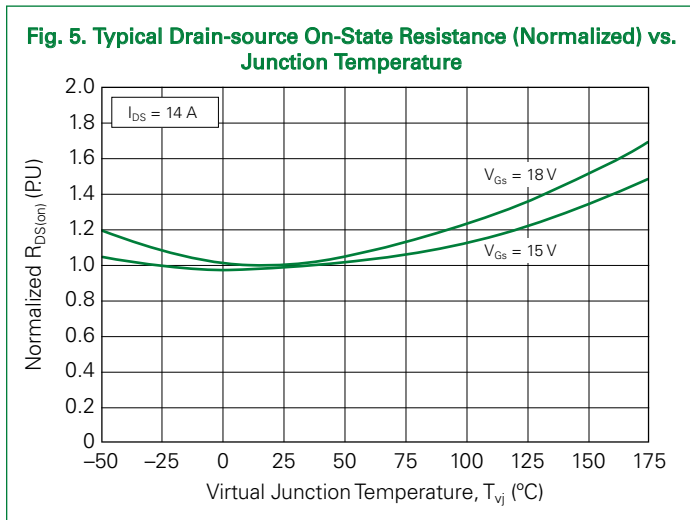
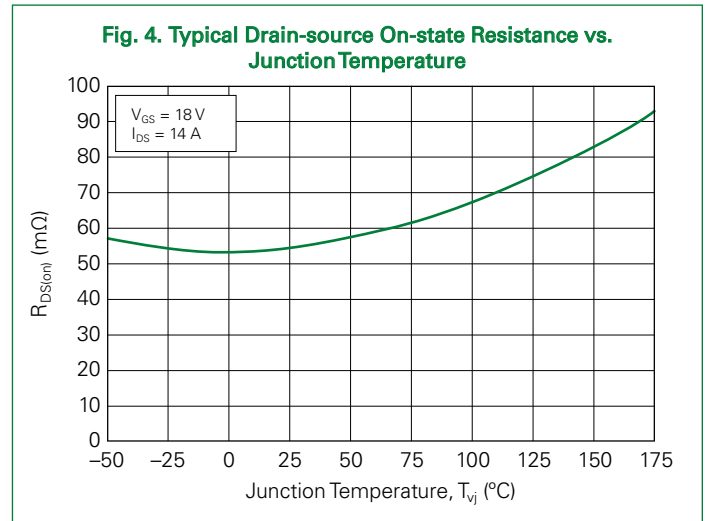
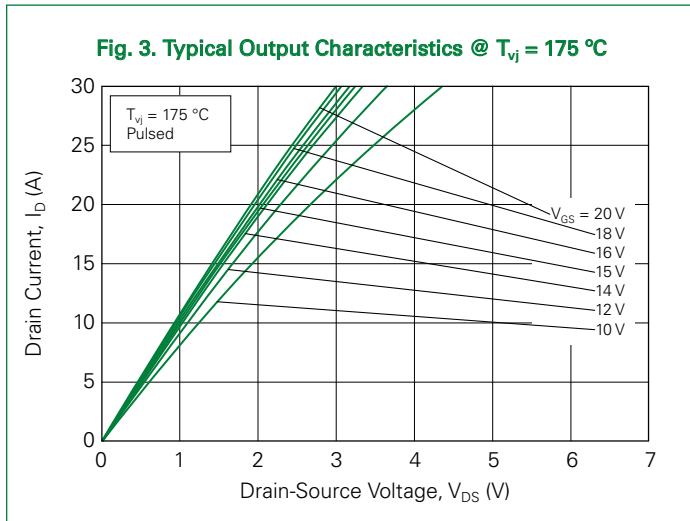
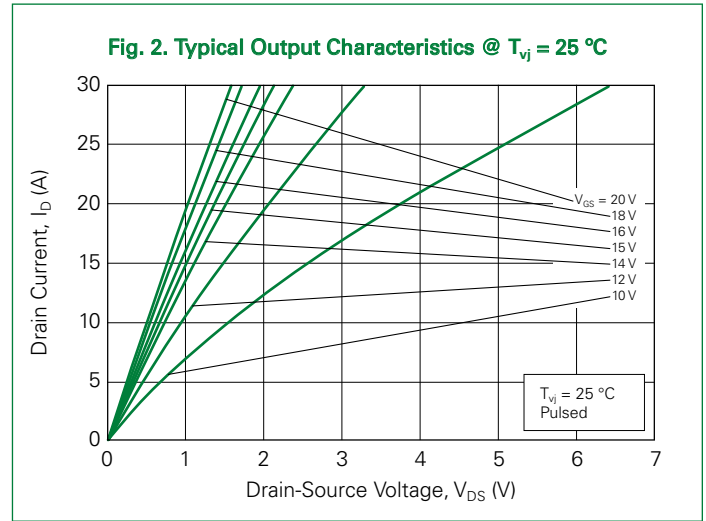
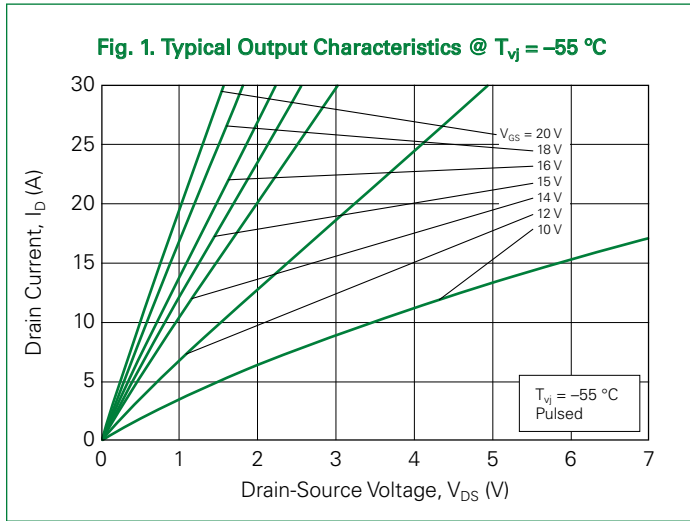

Fig. 7. $R_{DS(on)}$ vs. Temperature

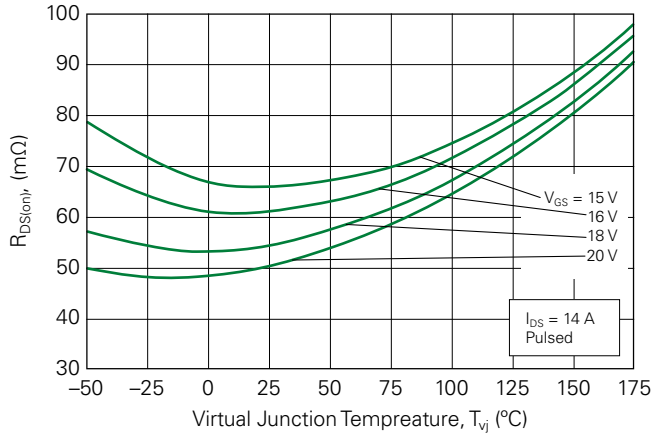

Fig. 8. Transfer Curves

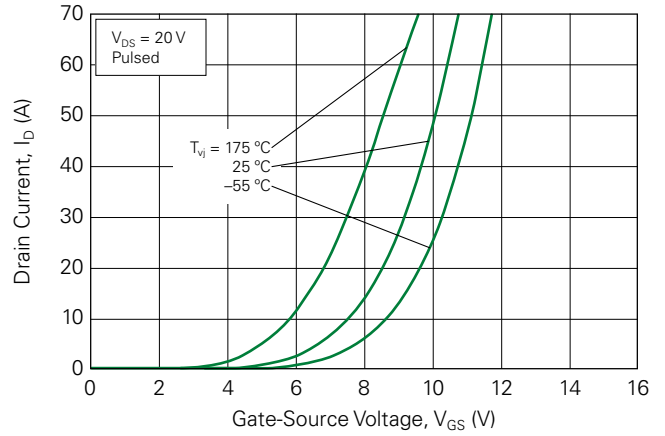

Fig. 9. Threshold Voltage vs. Temperature

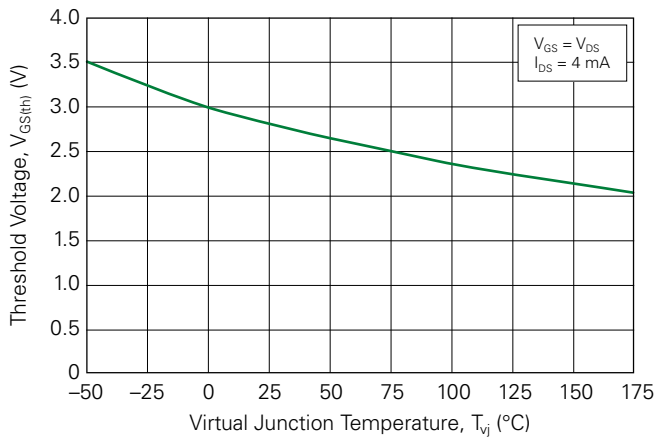

Fig. 10. Body Diode Curves @ $T_{vj} = -55$ °C

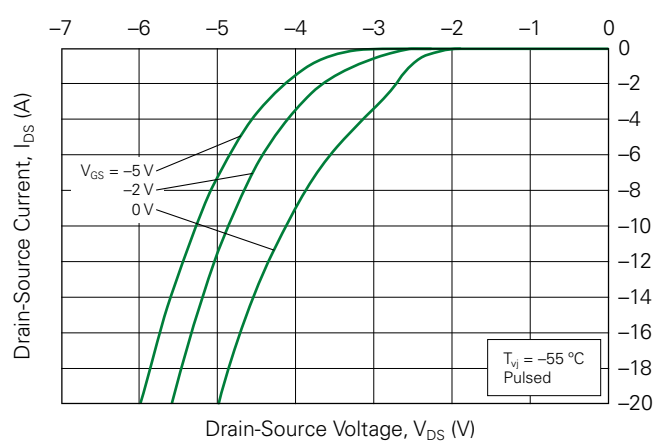

Fig. 11. Body Diode Curves @ $T_{vj} = 25$ °C

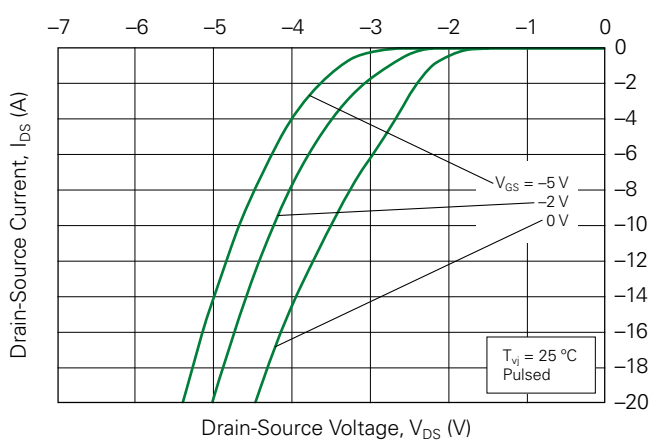

Fig. 12. Body Diode Curves @ $T_{vj} = 175$ °C

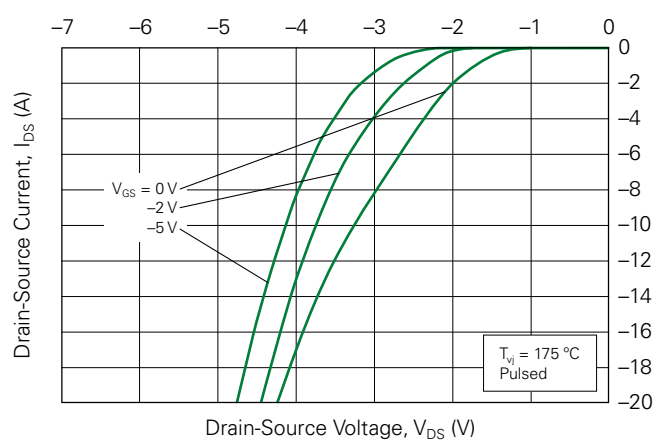

Fig. 13. 3rd Quadrant Curves @ $T_{vj} = -55\text{ }^\circ\text{C}$

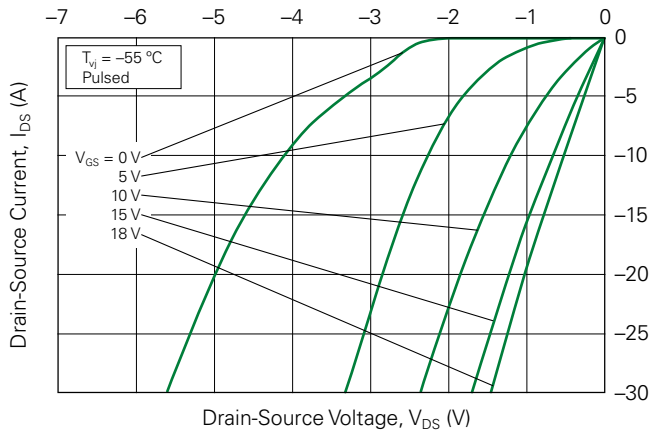

Fig. 14. 3rd Quadrant Curves @ $T_{vj} = 25\text{ }^\circ\text{C}$

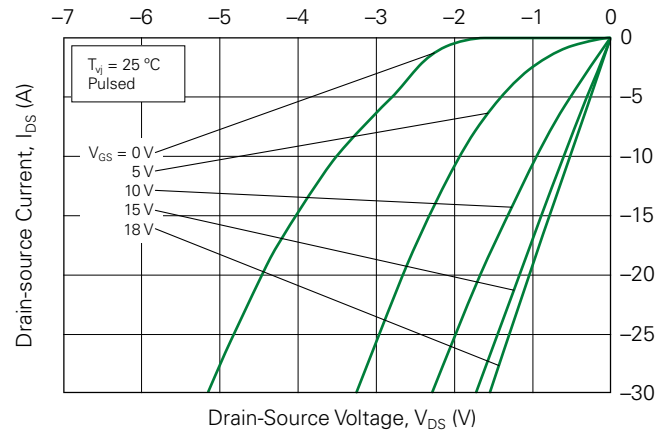

Fig. 15. 3rd Quadrant Curves @ $T_{vj} = 175\text{ }^\circ\text{C}$

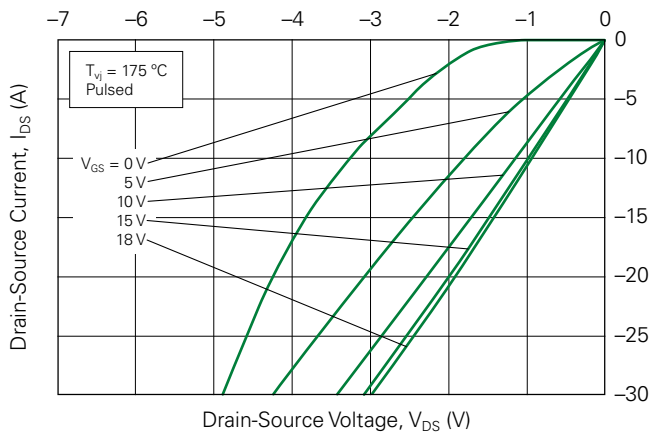

Fig. 16. Capacitance vs. V_{DS}

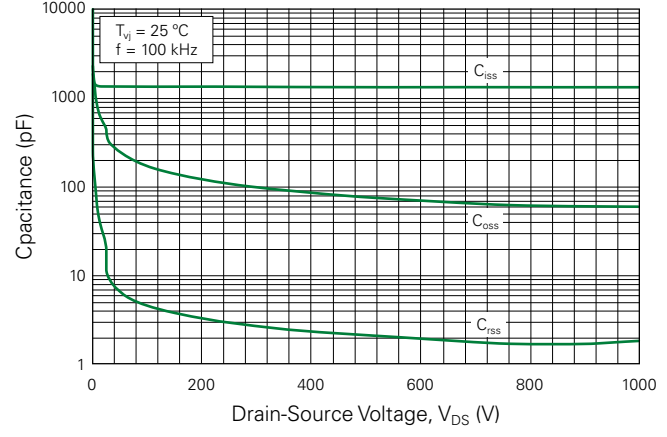

Fig. 17. Output Capacitor Stored Energy

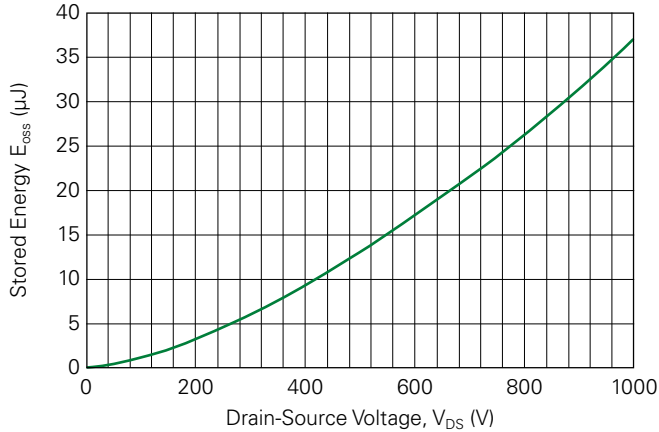
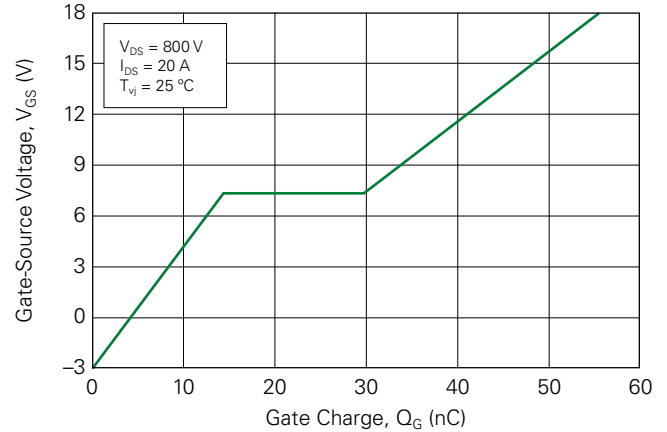
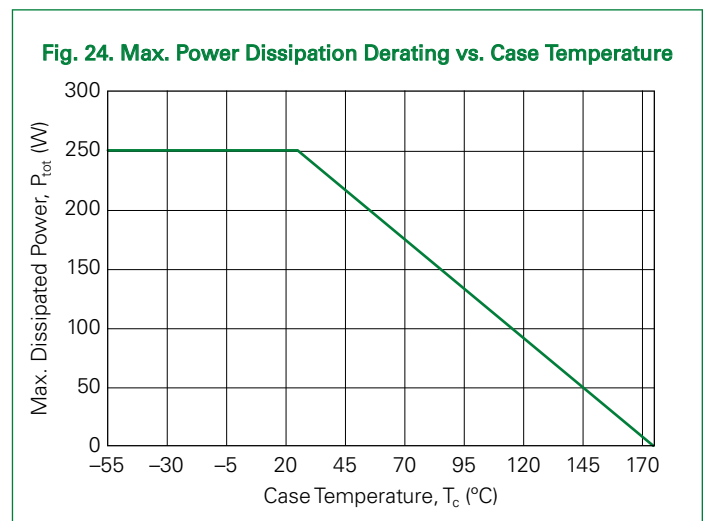
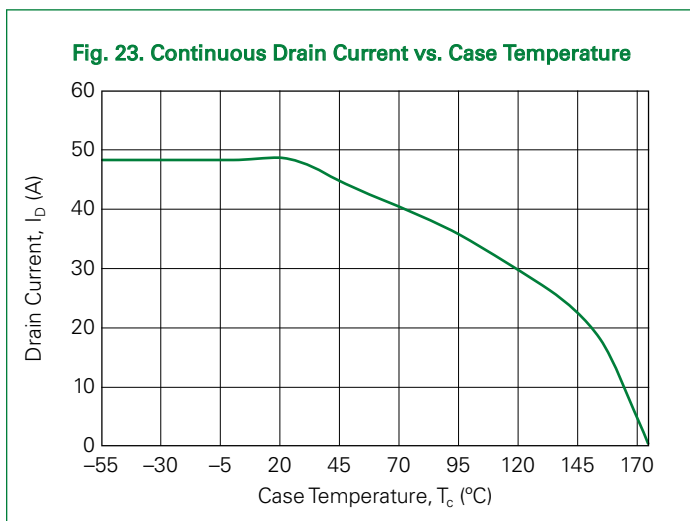
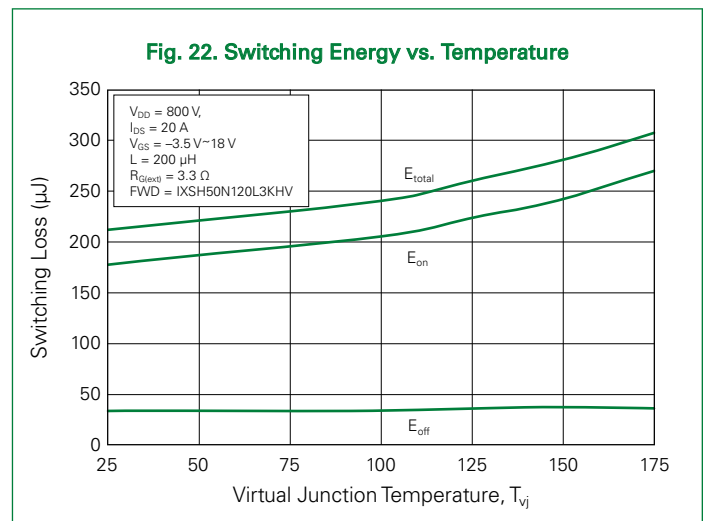
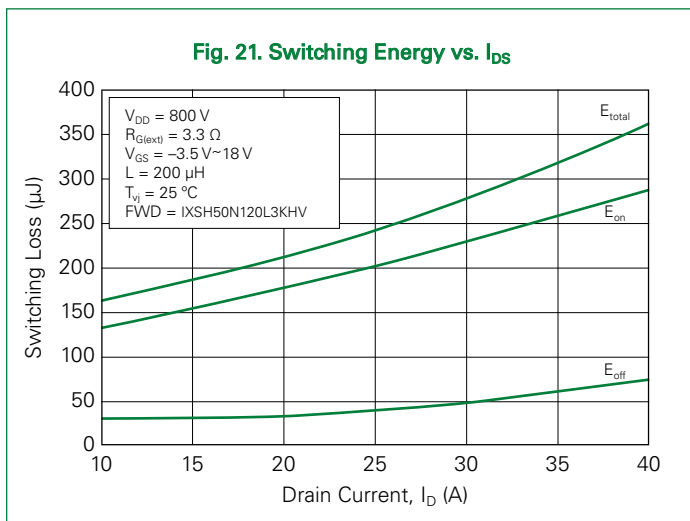
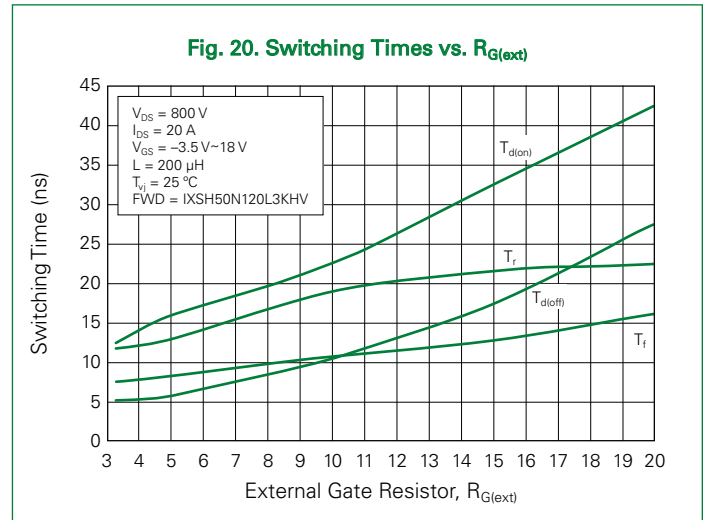
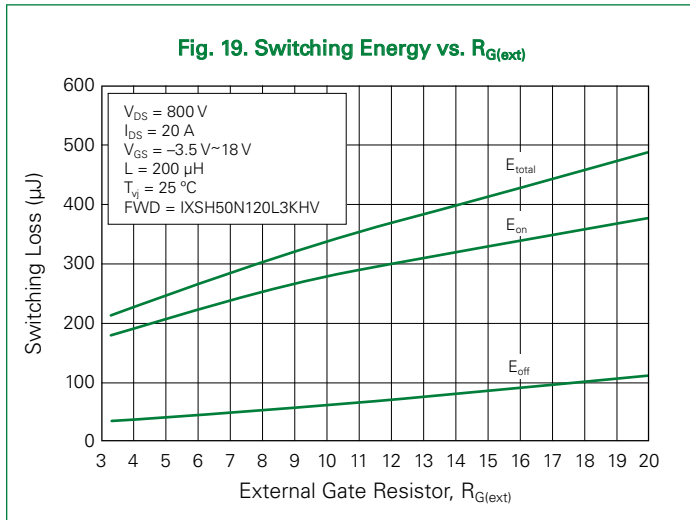
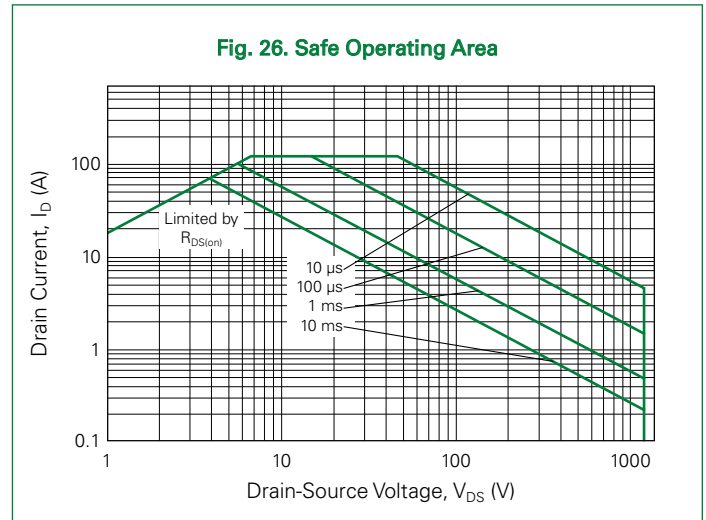
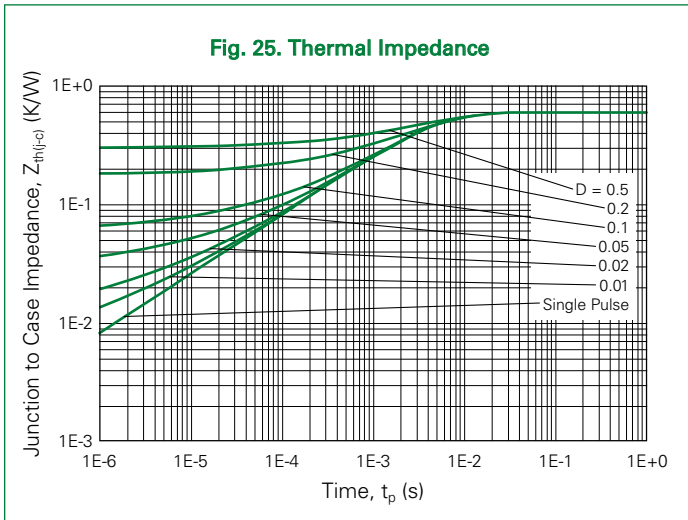

Fig. 18. Gate Charge Characteristics







Part Number and Marking

- IXSH50N120L3KHV = Device Part Number
- YY = Year
- WW = Work Week
- Z = Assembly Location
- XXXX = Lot Traceability

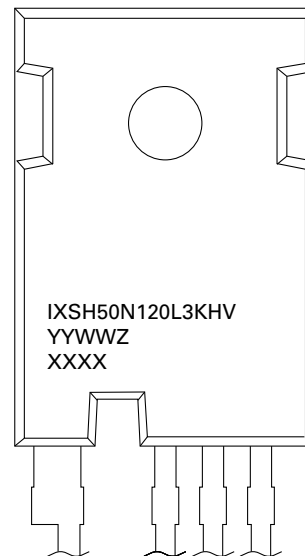

Part Outline Drawing (TO-247-4L)

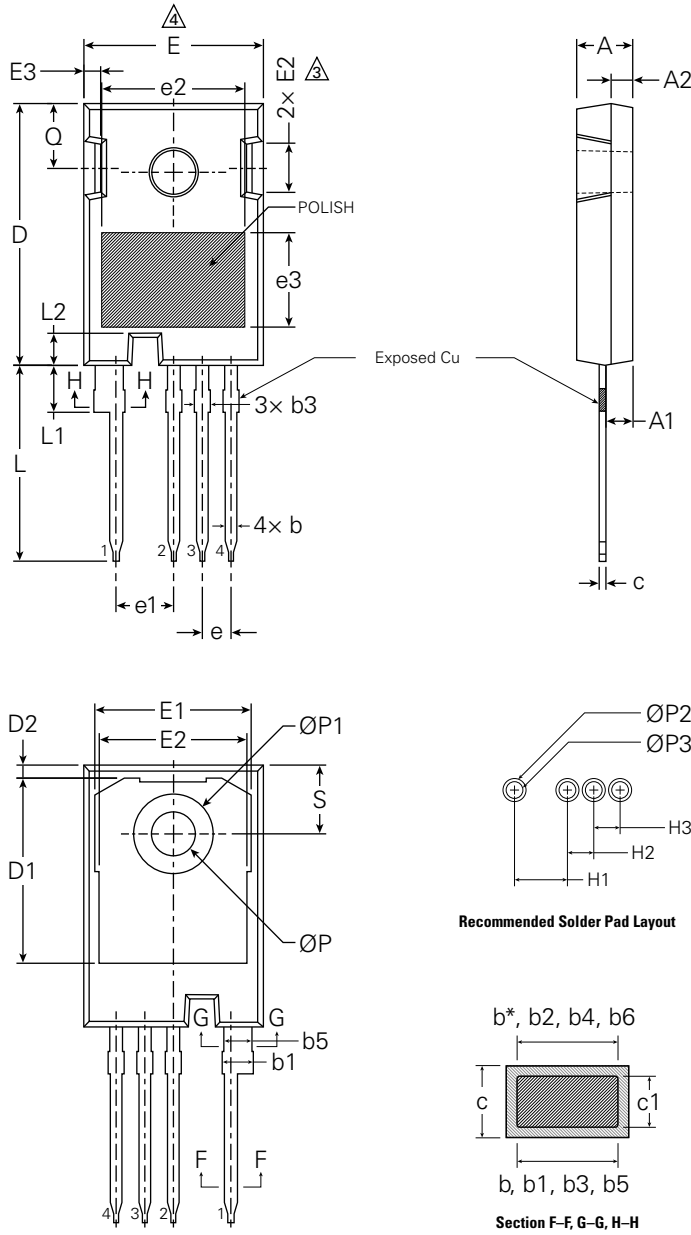

Note:

1. Package reference: JEDEC TO247, Variation AD
- △ Slot required, notch may be rounded
- △ Dimension D&E do not include mold flash
4. Subject to change without notice

Symbol	Inches			Millimeters		
	Min.	Typical	Max.	Min.	Typical	Max
A	0.190	-	0.205	4.83	-	5.21
A1	0.090	-	0.100	2.29	-	2.54
A2	0.075	-	0.085	1.91	-	2.16
b	0.042	-	0.052	1.07	-	1.33
b*	0.042	-	0.050	1.07	-	1.28
b1	0.094	-	0.116	2.39	-	2.94
b2	0.094	-	0.112	2.39	-	2.84
b3	0.042	-	0.063	1.07	-	1.60
b4	0.042	-	0.059	1.07	-	1.50
b5	0.094	-	0.106	2.39	-	2.69
b6	0.094	-	0.104	2.39	-	2.64
c	0.022	-	0.027	0.55	-	0.68
c1	0.022	-	0.026	0.55	-	0.65
D	0.917	-	0.929	23.30	-	23.60
D1	0.640	-	0.695	16.25	-	17.65
D2	0.037	-	0.049	0.95	-	1.25
E	0.620	-	0.635	15.75	-	16.13
E1	0.516	-	0.557	13.10	-	14.15
E2	0.145	-	0.201	3.68	-	5.10
E3	0.039	-	0.075	1.00	-	1.90
E4	0.487	-	0.529	12.38	-	13.43
e	0.100 BSC			2.54 BSC		
e1	0.200 BSC			5.08 BSC		
e2	-	0.500	-	-	12.70	-
e3	-	0.330	-	-	8.38	-
H1	-	0.200	-	-	5.08	-
H2	-	0.100	-	-	2.54	-
H3	-	0.100	-	-	2.54	-
L	0.681	-	0.702	17.31	-	17.82
L1	0.156	-	0.172	3.97	-	4.37
L2	0.093	-	0.104	2.35	-	2.65
ØP	0.138	-	0.144	3.51	-	3.65
ØP1	0.283 REF.			7.18 REF.		
ØP2	-	0.088	-	-	2.24	-
ØP3	-	0.067	-	-	1.70	-
Q	0.216	-	0.236	5.49	-	6.00
S	0.238	-	0.248	6.04	-	6.30

Disclaimer Notice

Information furnished is believed to be accurate and reliable. However, users should independently evaluate the suitability of and test each product selected for their own applications. Littelfuse products are not designed for, and may not be used in, all applications. Read complete Disclaimer Notice at <http://www.littelfuse.com/disclaimer-electronics>.



Part of:

