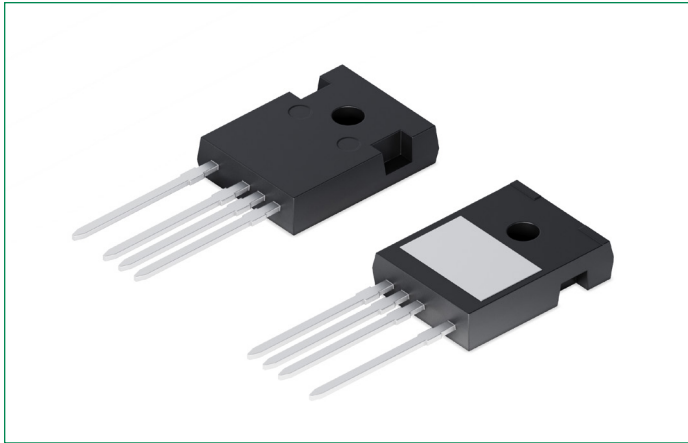
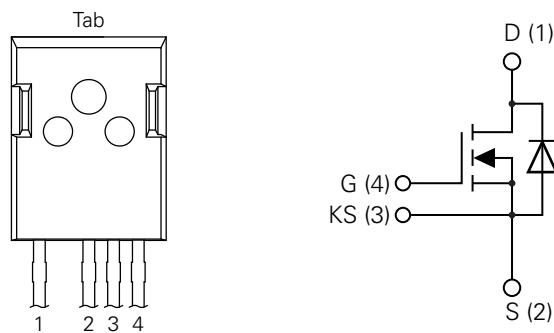

IXSJ25N120R1K

1200 V, 62 mΩ, 28 A SiC Power MOSFET

RoHS HF UL E153432

**Pinout Diagram** (ISO247-4L)**1:** Drain; **2:** Source; **3:** Kelvin Source; **4:** Gate; **Tab:** Isolated**Features**

- Up to 1200 V blocking voltage with low $R_{DS(on)}$ of 62 mΩ
- Low gate charge of 49 nC and low input capacitance of 1451 pF
- Flexible gate voltage range (15–18 V) and 0 V recommended turn-off gate voltage

Benefits

- Low conduction losses and reduced heat dissipation
- Low gate drive power requirements
- Supports high-speed switching with reduced gate drive losses

ISO247-4L Package

- High performance ceramic based isolated package improves overall thermal resistance $R_{th(j-h)}$ and power handling capability
- Isolation voltage 2500V AC (RMS), 1 minute
- Reduced EMI attributed to the small chip-to-heatsink stray capacitance
- Industry standard package outline
- Optimized package with separate driver source pin

Applications

- EV charging infrastructure
- Solar inverters
- Switch mode power supplies
- Uninterruptible power supply
- Motor drives
- DC/DC converters
- Battery chargers
- Induction heating
- High-frequency applications

Product Summary

Characteristic	Value	Unit
I_{D25}	28	A
V_{DSS}	1200	V
$R_{DS(on) typ}$	62	mΩ

Maximum Ratings ($T_{vj} = 25\text{ °C}$ unless otherwise specified)

Symbol	Characteristics	Conditions	Value			Unit	
			Min.	Typ.	Max.		
V_{DSS}	Drain-source voltage	$V_{GS} = 0\text{ V}, I_D = 5.3\text{ mA}, T_{vj} = 25\text{ °C}$	–	1200	–	V	
V_{GSM}	Maximum gate-source voltage	Gate-source voltage (DC)	–4	–	+21	V	
	Transient gate-source voltage	Transient, $t_{transient} < 300\text{ ns}$	–4	–	+23	V	
I_D	Drain current	$V_{GS} = 18\text{ V}$	$T_c = 25\text{ °C}$	–	28	–	A
			$T_c = 80\text{ °C}$	–	23	–	
			$T_c = 100\text{ °C}$	–	21	–	
I_{DM}	Peak drain current	$T_c = 25\text{ °C}$, pulse width limited by $T_{vj(max)}$	–	49	–	A	
I_S	Diode forward current	$V_{GS} = 0\text{ V}, T_c = 25\text{ °C}$	–	22	–	A	
I_{SM}	Body-diode surge forward current	Pulse width limited by $T_{vj(max)}$	–	44	–	A	
P_{tot}	Total power dissipation	$T_c = 25\text{ °C}$	–	79.6	–	W	
T_{vj}	Virtual junction temperature range	–	–40	–	+150	°C	
$T_{vj(max)}$	Maximum virtual junction temperature	–	–	150	–	°C	
T_{stg}	Storage temperature range	–	–40	–	+150	°C	
F_C	Mounting force with clip	–	40	–	130	N	
T_{sold}	Soldering temperature	3 mm (1/8 in.) from case 10 s	–	260	–	°C	
$d_{Spp/App}$ $d_{Spb/Abp}$	Creepage distance on surface / Clearance distance through air	Terminal to terminal	Between pin 1 to 2	3.88	–	–	mm
			Between pin 2 to 3	1.34	–	–	
			Between pin 3 to 4	1.34	–	–	
	For all terminals	2.4	–	–			
Clearance distance through air Creepage distance on surface	Terminal to backside plane	Terminal to backside tab	For all terminals	5.26	–	–	
	5.26			–	–		
V_{ISOL}	Isolation voltage	50/60 Hz; RMS; $I_{ISOL} < 1\text{ mA}, t = 1\text{ second}$	–	3000	–	V	
		50/60 Hz; RMS; $I_{ISOL} < 1\text{ mA}, t = 1\text{ minute}$	–	2500	–		
M	Package weight	–	–	8	–	g	

Recommended Values

Symbol	Characteristics	Conditions	Value	Unit
$V_{GS(on)}$	Recommended turn-on gate-source voltage	–	18	V
$V_{GS(off)}$	Recommended turn-off gate-source voltage	–	0	V

Thermal Characteristics

Symbol	Characteristics	Conditions	Value			Unit
			Min.	Typ.	Max.	
$R_{th(j-c)}$	Thermal resistance, junction-to-case	–	–	–	1.57	K/W

Electrical Characteristics – Static ($T_{vj} = 25\text{ °C}$ unless otherwise specified)

Symbol	Characteristics	Conditions	Ratings			Unit
			Min.	Typ.	Max.	
$V_{(BR)DSS}$	Breakdown voltage, drain-source	$V_{GS} = 0\text{ V}, I_D = 5.3\text{ mA}, T_{vj} = 25\text{ °C}$	1200	–	–	V
$V_{GS(TH)}$	Gate threshold voltage	$V_{DS} = V_{GS}, I_D = 6.45\text{ mA}$	2.8	–	4.8	V
		$V_{DS} = V_{GS}, I_D = 6.45\text{ mA}, T_{vj} = 150\text{ °C}$	–	2.8	–	
I_{DSS}	Zero gate voltage drain current	$V_{DS} = 1200\text{ V}, V_{GS} = 0\text{ V}$	–	1	80	μA
		$V_{DS} = 1200\text{ V}, V_{GS} = 0\text{ V}, T_{vj} = 150\text{ °C}$	–	10	–	
$I_{GSS,F}$ $I_{GSS,R}$	Gate leakage current	$V_{GS} = 21\text{ V}, V_{DS} = 0\text{ V}$	–	–	100	nA
		$V_{GS} = -4\text{ V}, V_{DS} = 0\text{ V}$	–	–	–100	
$R_{DS(on)}$	Drain-source On-state resistance	$I_D = 12\text{ A}, V_{GS} = 18\text{ V}$	–	62	81	mΩ
		$I_D = 12\text{ A}, V_{GS} = 18\text{ V}, T_{vj} = 150\text{ °C}$	–	124	–	
$R_{g(int)}$	Internal gate resistance	Resonance method, Drain-Source shorted ¹	–	4	–	Ω
g_{fs}	Transconductance	$V_{DS} = 10\text{ V}, I_D = 12\text{ A}$	–	8.3	–	S

Note 1: For a description of the resonance method for measuring R_g , refer to the JEDEC Standard JESD24-11 test method

Electrical Characteristics – Dynamic ($T_{vj} = 25\text{ }^{\circ}\text{C}$ unless otherwise specified)

Symbol	Characteristics	Conditions	Ratings			Unit	
			Min.	Typ.	Max.		
C_{iss}	Input capacitance	$V_{DD} = 800\text{ V}, V_{GS} = 0\text{ V},$ $f = 1\text{ MHz}$	–	1451	–	pF	
C_{oss}	Output capacitance		–	49	–		
C_{riss}	Reverse transfer capacitance		–	3	–		
Q_g	Total gate charge	$V_{DD} = 800\text{ V}, I_D = 12\text{ A},$ $V_{GS} = 0/+18\text{ V}, R_{g(ext)} = 0\text{ }^{\Omega}, L = 250\text{ }^{\mu}\text{H},$ FWD: body diode	–	49	–	nC	
Q_{gs}	Gate-source charge		–	14	–		
Q_{gd}	Gate-drain charge		–	12	–		
E_{oss}	Output capacitance charge energy	$V_{DS} = 800\text{ V}, V_{GS} = 0\text{ V}, F = 1\text{ MHz}$	–	16	–	μJ	
$t_{d(on)}$	Turn-on delay time	Inductive Switching Free wheeling diode: body diode $V_{DD} = 800\text{ V}, V_{GS} = 0/+18\text{ V},$ $I_D = 12\text{ A}, R_{g(ext)} = 0\text{ }^{\Omega}$	$T_{vj} = 25\text{ }^{\circ}\text{C}$	–	10	–	ns
			$T_{vj} = 150\text{ }^{\circ}\text{C}$	–	10	–	
t_r	Rise time		$T_{vj} = 25\text{ }^{\circ}\text{C}$	–	12	–	ns
			$T_{vj} = 150\text{ }^{\circ}\text{C}$	–	11	–	
t_{on}	Turn-on time		$T_{vj} = 25\text{ }^{\circ}\text{C}$	–	22	–	ns
			$T_{vj} = 150\text{ }^{\circ}\text{C}$	–	21	–	
E_{on}	Turn-on energy per pulse		$T_{vj} = 25\text{ }^{\circ}\text{C}$	–	106	–	μJ
			$T_{vj} = 150\text{ }^{\circ}\text{C}$	–	108	–	
$t_{d(off)}$	Turn-off delay time		$T_{vj} = 25\text{ }^{\circ}\text{C}$	–	21	–	ns
			$T_{vj} = 150\text{ }^{\circ}\text{C}$	–	24	–	
t_f	Fall time		$T_{vj} = 25\text{ }^{\circ}\text{C}$	–	8	–	ns
			$T_{vj} = 150\text{ }^{\circ}\text{C}$	–	8	–	
t_{off}	Turn-off time		$T_{vj} = 25\text{ }^{\circ}\text{C}$	–	29	–	ns
			$T_{vj} = 150\text{ }^{\circ}\text{C}$	–	32	–	
E_{off}	Turn-off energy per pulse		$T_{vj} = 25\text{ }^{\circ}\text{C}$	–	41	–	μJ
			$T_{vj} = 150\text{ }^{\circ}\text{C}$	–	39	–	
E_{tot}	Total switching energy		$T_{vj} = 25\text{ }^{\circ}\text{C}$	–	147	–	μJ
			$T_{vj} = 150\text{ }^{\circ}\text{C}$	–	146	–	

Reverse Diode Characteristics ($T_{vj} = 25\text{ }^{\circ}\text{C}$ unless otherwise specified)

Symbol	Characteristics	Conditions	Ratings			Unit		
			Min.	Typ.	Max.			
V_{SD}	Forward voltage drop	$I_{SD} = 12\text{ A}, V_{GS} = 0\text{ V}$	–	3.2	–	V		
		$I_{SD} = 12\text{ A}, V_{GS} = 0\text{ V}, T_{vj} = 150\text{ }^{\circ}\text{C}$	–	3.3	–			
t_{rr}	Reverse recovery time	$V_{GS} = 0\text{ V}, I_F = 12\text{ A}, V_R = 800\text{ V}$ MOSFET Gate Drive: $R_{g(ext)} = 0\text{ }^{\Omega}$	$T_{vj} = 25\text{ }^{\circ}\text{C}$	–	9	–	ns	
			$T_{vj} = 150\text{ }^{\circ}\text{C}$	–	9	–		
Q_{rr}	Reverse recovery charge		$T_{vj} = 25\text{ }^{\circ}\text{C}$	–	106	–	nC	
				–	113	–		
I_{rrm}	Peak reverse recovery current		$T_{vj} = 25\text{ }^{\circ}\text{C}$	–	21	–	A	
				–	21	–		
di_f/dt	Current slew rate		$T_{vj} = 25\text{ }^{\circ}\text{C}$	–	5176	–	A/ μs	
			$T_{vj} = 150\text{ }^{\circ}\text{C}$	–	5068	–		
$E_{rec(off)}$	Turn-off energy of intrinsic diode per pulse		Inductive load, $V_{DD} = 800\text{ V}, V_{GS} = 0/+18\text{ V},$ $I_S = 12\text{ A}, R_{g(ext)} = 0\text{ }^{\Omega}, L = 250\text{ }^{\mu}\text{H}$	$T_{vj} = 25\text{ }^{\circ}\text{C}$	–	33	–	μJ
				$T_{vj} = 150\text{ }^{\circ}\text{C}$	–	36	–	

Characteristic Curves

Fig. 1. Typical Transfer Characteristics

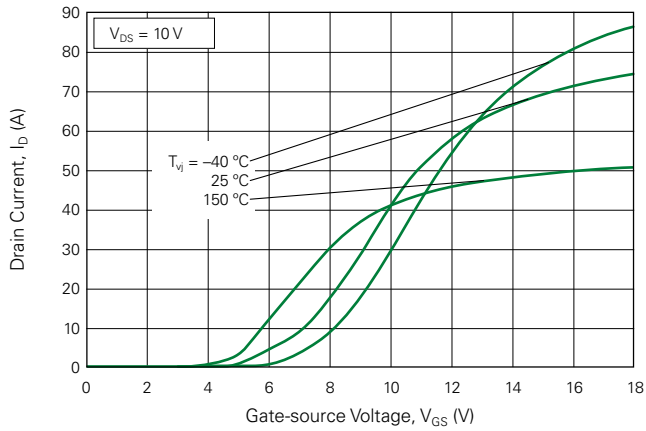

Fig. 2. Typical Transconductance

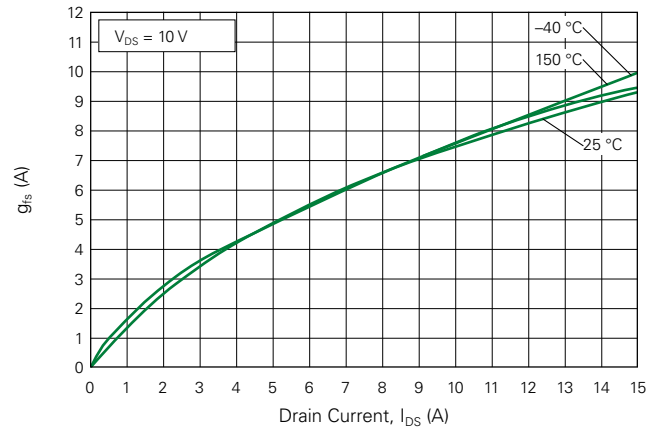

Fig. 3. Typical Output Characteristics @ $T_{vj} = 25^\circ\text{C}$

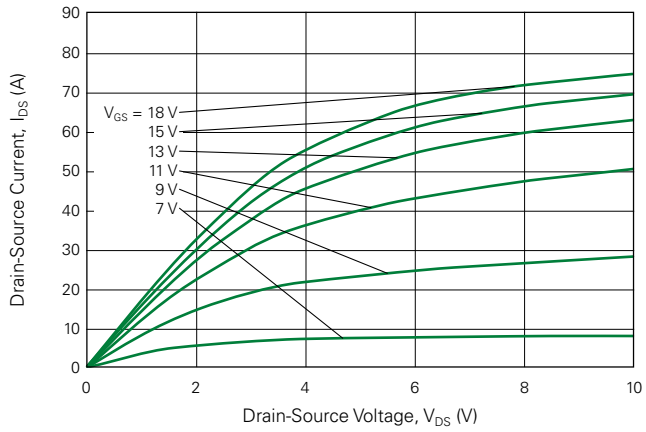

Fig. 4. Typical Output Characteristics @ $T_{vj} = 150^\circ\text{C}$

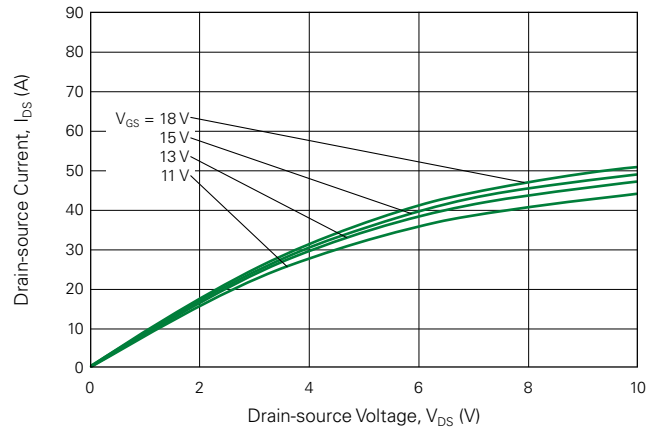

Fig. 5. Typical Output Characteristics @ $T_{vj} = -40^\circ\text{C}$

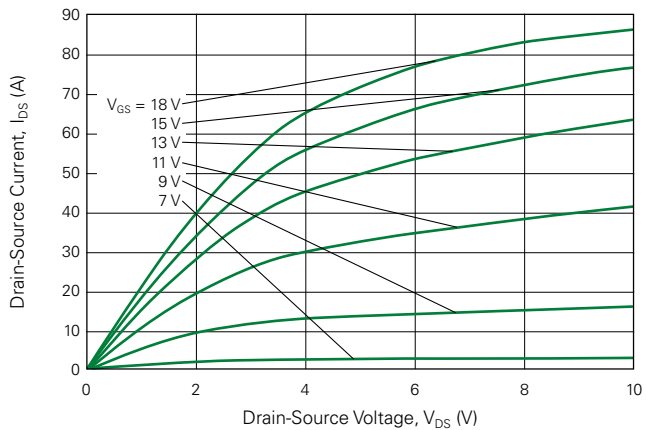

Fig. 6. $R_{DS(on)}$ Normalized to $I_D = 12$ A vs. Drain Current

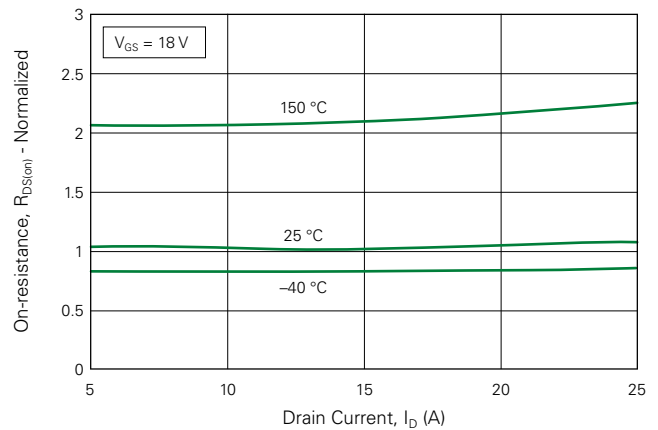

Fig. 7. $R_{DS(on)}$ Normalized to $I_D = 12\text{ A}$ vs. Junction Temperature

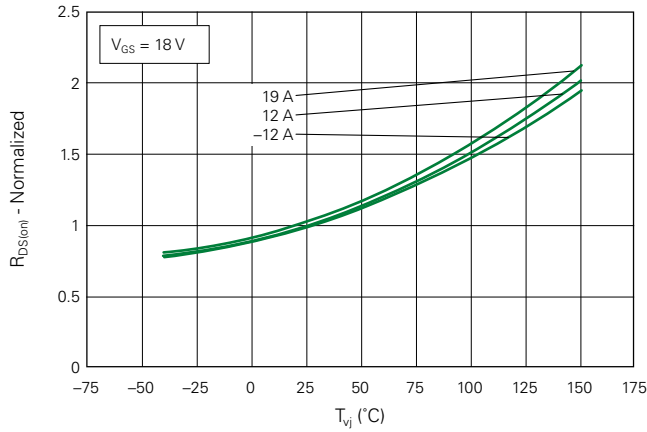

Fig. 8. Typical Drain-source On-state Resistance vs. Gate-source Voltage

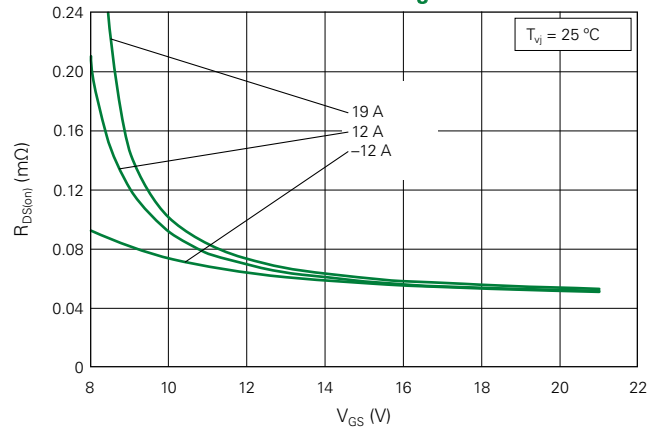

Fig. 9. Typical $V_{(BR)DSS}/V_{GS(th)}$ (Normalized) vs. Virtual Junction Temperature

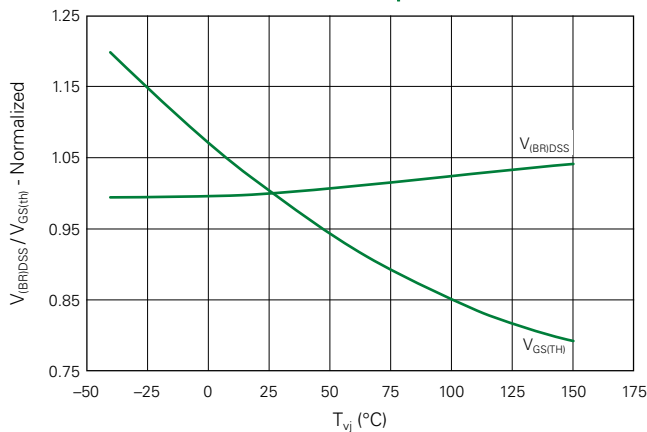

Fig. 10. Typical Reverse Conduction Characteristics @ $T_{vj} = -40\text{ °C}$

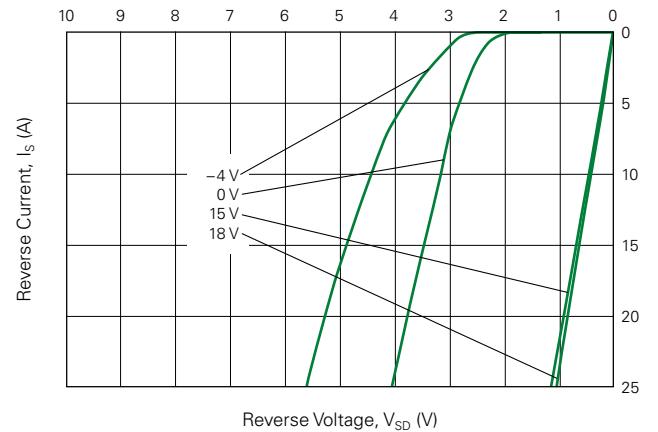

Fig. 11. Typical Reverse Conduction Characteristics @ $T_{vj} = 25\text{ °C}$

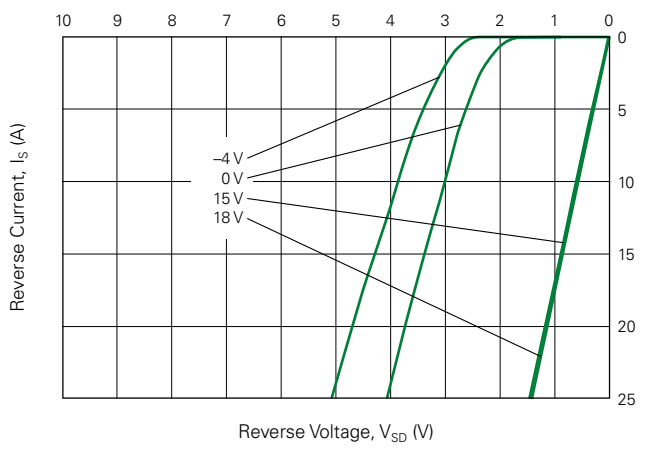

Fig. 12. Typical Reverse Conduction Characteristics @ $T_{vj} = 150\text{ °C}$

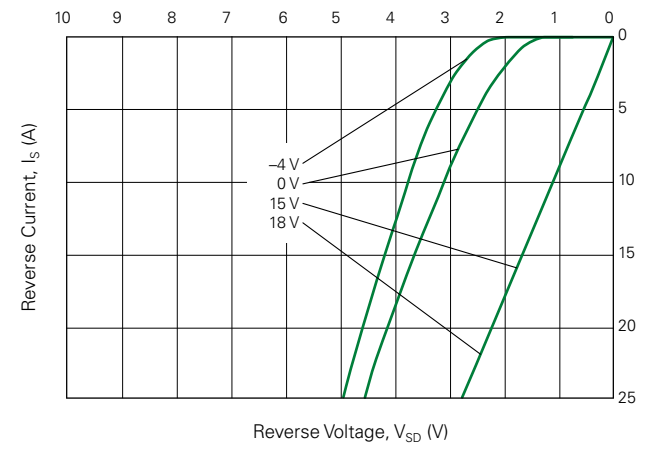

Fig. 13. Typical On-resistance vs. Junction Temperature

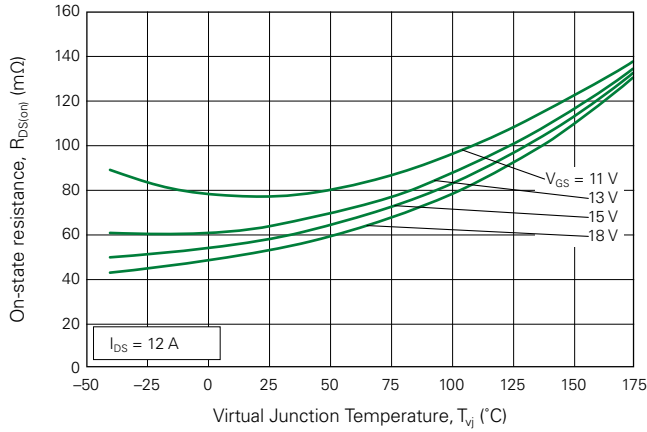

Fig. 14. Typical Threshold Voltage

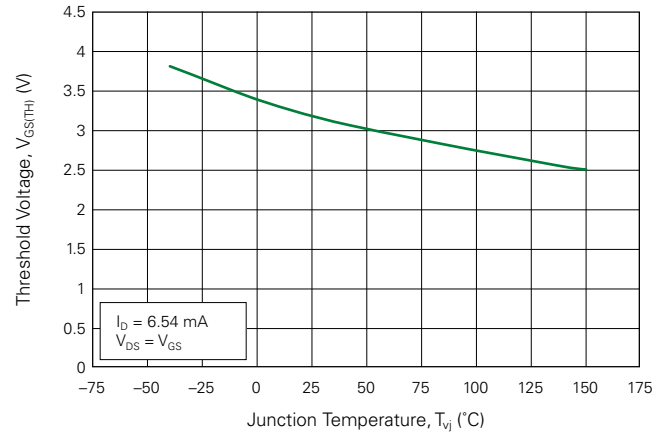

Fig. 15. Body Diode Forward Voltage vs. Gate-source Voltage

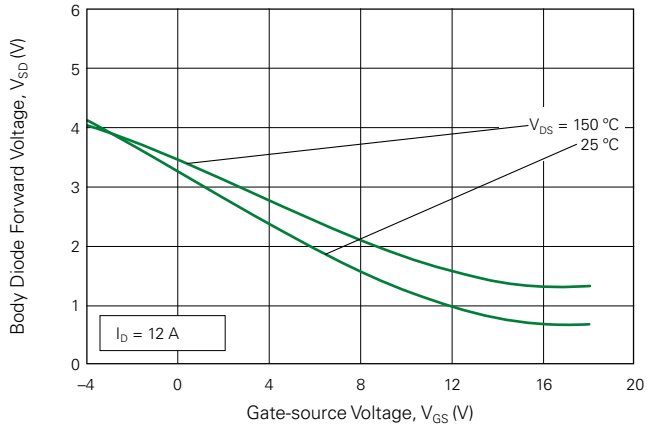

Fig. 16. Gate Charge Characteristics

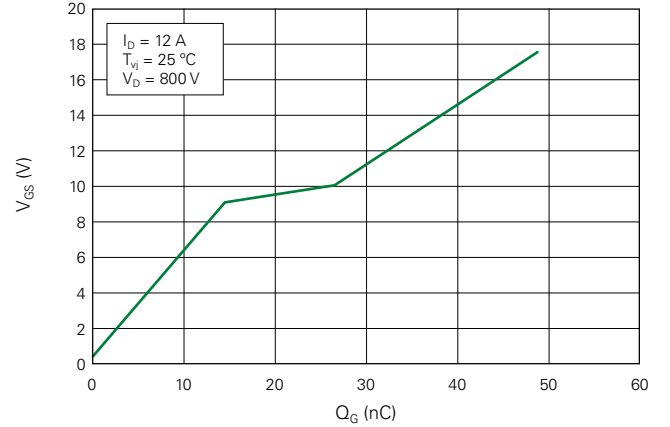

Fig. 17. Capacitance vs. V_{DS}

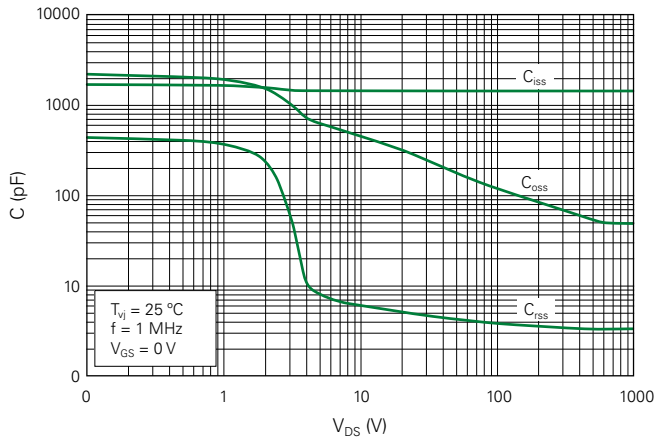

Fig. 18. Output Capacitance C_{oss} Stored Energy

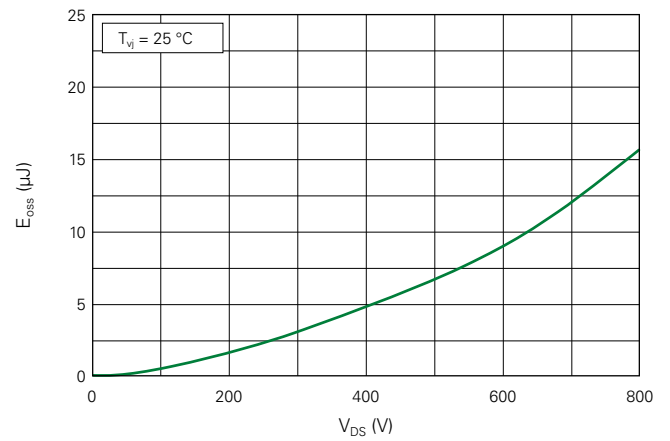

Fig. 19. Typical Switching Time vs. External Gate Resistor

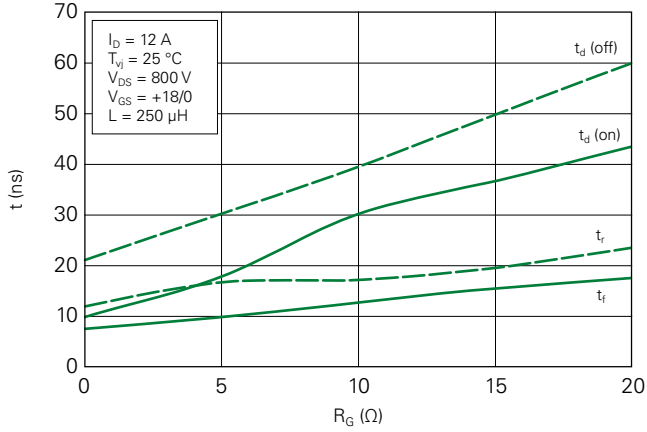

Fig. 20. Typical Switching Energy vs. Drain Current

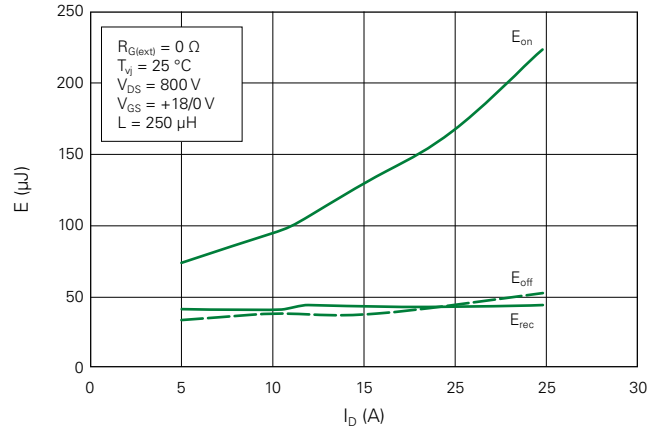

Fig. 21. Typical Switching Energy vs. External Gate Resistor

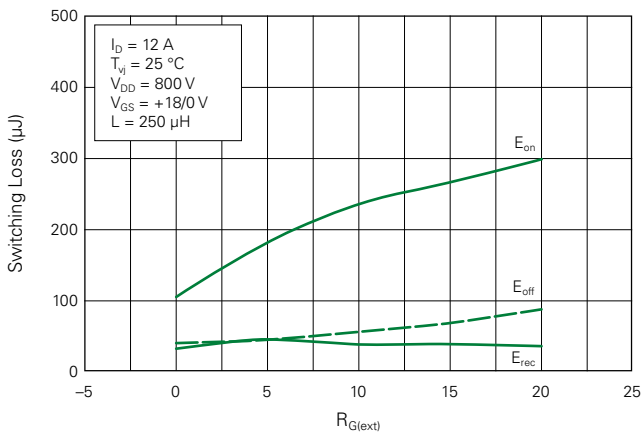

Fig. 22. Typical Switching Energy vs. Junction Temperature

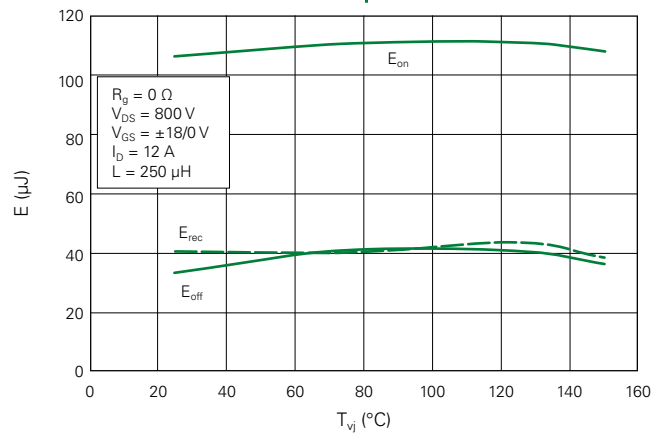

Fig. 23. Typical Reverse Recovery Charge vs. Diode Recovery Current Slope

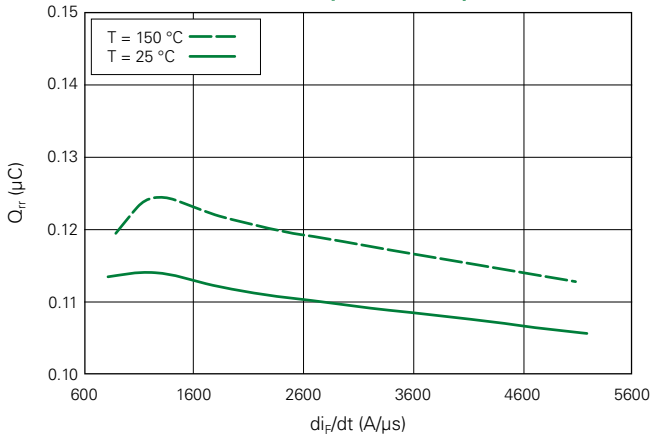

Fig. 24. Typical Reverse Recovery Current vs. Diode Recovery Current Slope

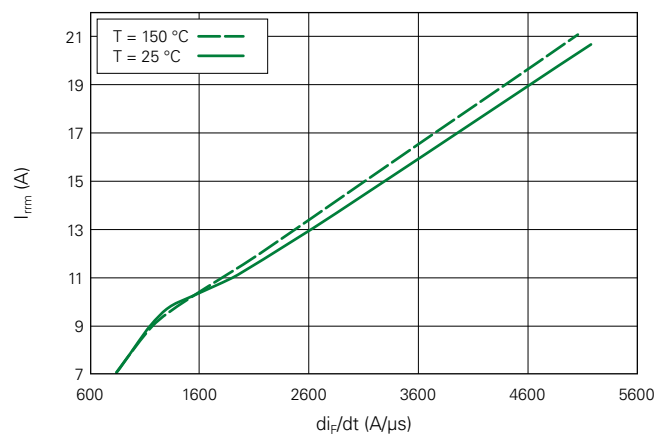

Fig. 25. Thermal Impedance (Normalized)

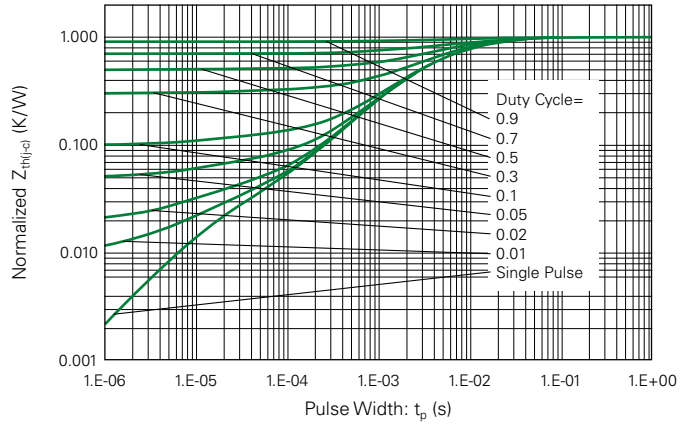
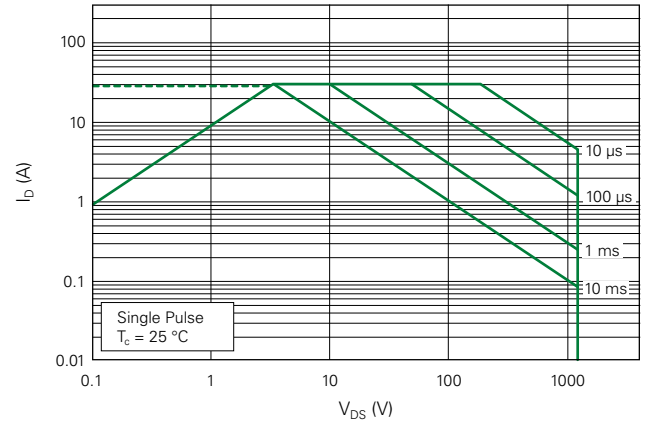
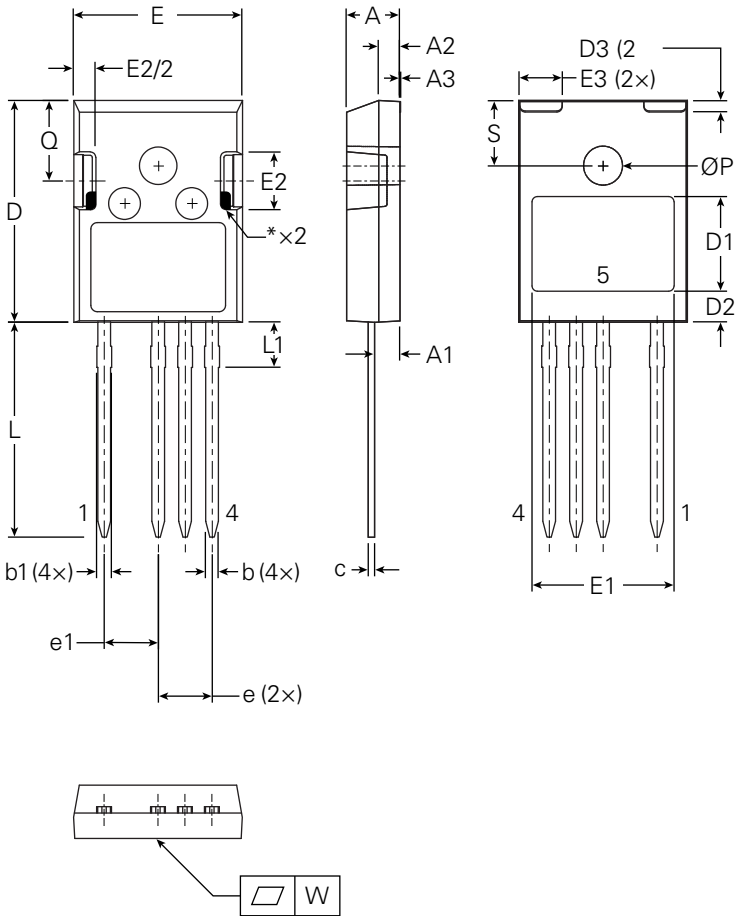

Fig. 26. Maximum Safe Operating Area ($T_c = 25^\circ\text{C}$)



Part Outline Drawing (ISO247-4L)



Symbol	Inches			Millimeters		
	Min.	Typical	Max.	Min.	Typical	Max
A	0.185	-	0.205	4.70	-	5.21
A1	0.087	-	0.102	2.21	-	2.59
A2	0.059	-	0.098	1.50	-	2.49
A3	0.002 TYP			0.05 TYP		
b	0.039	-	0.055	0.99	-	1.40
b1	0.043	-	0.059	1.10	-	1.50
c	0.015	-	0.035	0.38	-	0.89
D	0.819	-	0.844	20.80	-	21.45
D1	0.360 TYP			9.15 TYP		
D2	0.110 TYP			2.80 TYP		
D3	0.039 TYP			1.00 TYP		
E	0.610	-	0.639	15.49	-	16.24
E1	0.528 TYP			13.40 TYP		
E2	0.170	-	0.216	4.32	-	5.48
E3	0.157 TYP			4.00 TYP		
e	0.100 BSC			2.54 BSC		
e1	0.200 BSC			5.08 BSC		
L	0.780	-	0.799	19.81	-	20.30
L1	-	-	0.177	-	-	4.49
Q	0.290	-	0.306	7.36	-	7.76
ØP	0.140	-	0.144	3.56	-	3.65
S	0.242 BSC			6.15 BSC		
W	0.004 TYP			0.10 TYP		

Note:

1. Bottom Heatsink #5 is Pre-Ni Plated and electrically isolated from Pin #1, #2, #3, and #4.
 2. Dimensions are exclusive of burrs, mold flash and tie bar extrusions.
 3. Drawing conforms to ASME 14.5-2009.
- * Exposed metal, electrically isolated.

Disclaimer Notice

Information furnished is believed to be accurate and reliable. However, users should independently evaluate the suitability of and test each product selected for their own applications. Littelfuse products are not designed for, and may not be used in, all applications. Read complete Disclaimer Notice at <http://www.littelfuse.com/disclaimer-electronics>.