

# Current Sensor

## CF1P023N



### General Description

The Littelfuse CF1P023N is a high-performance current sensor based on Closed Loop Fluxgate technology. The high linear output characteristics and high accuracy across the operating temperature range plus the small package size and PCB mounting capability make it an excellent solution for a wide range of applications.

### Standards

- EN50178: 1997
- IEC61010-1: 2010
- UL 508: 2013

### Functional Block Diagram

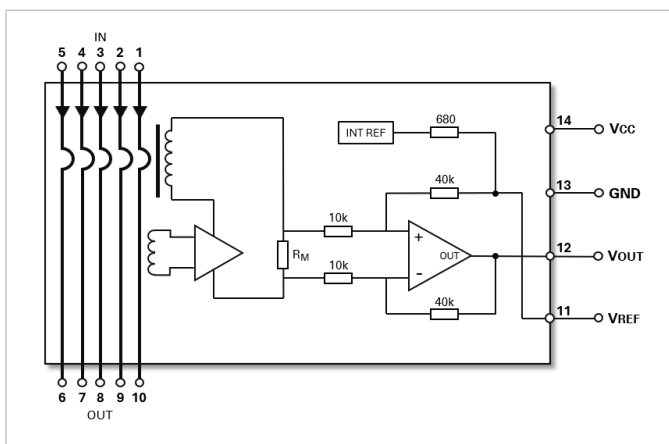

### Features

- Closed Loop Fluxgate sensor
- Single +5V power supply
- Voltage output
- Wide measuring range
- PCB through-hole mounting
- Operating temperature range:  
-40 °C < T < +105 °C
- Primary nominal RMS current: ±75A
- Primary measuring range: up to: ±220A  
See conditions in electrical data table

### Benefits

- Very small package size
- Easy mounting via automated handling
- Low offset current
- High immunity to external interference
- Low Temperature coefficient
- Short response time
- Wide frequency bandwidth

### Applications

- Static Converters for DC motor drives
- Solar inverters
- AC variable speed drives
- Servo motor drives
- Battery supplied applications
- Uninterruptible Power Supplies (UPS)
- Switched Mode Power Supplies (SMPS)

# Current Sensor

## CF1P023N

### Littelfuse Current Sensor Naming Convention

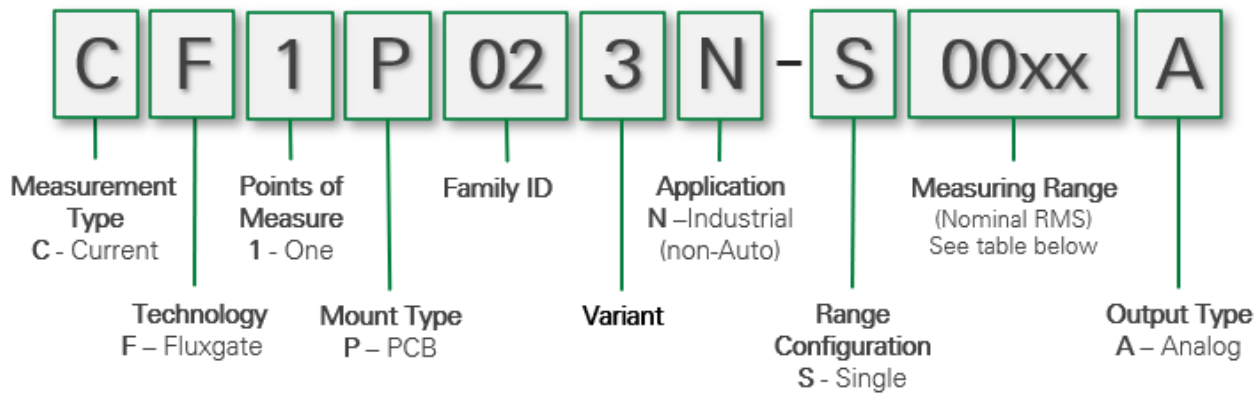

### Product Identification (per nominal RMS current range)

Part Name	Littelfuse Part Number	Nominal RMS Current
CF1P023N-S0075A	24949-00-01	±75 A

# Current Sensor

## CF1P023N

### Absolute Maximum Ratings

Symbol	Parameter	Value	Units
$T_A$	Ambient operating temperature	-40...+105	°C
$T_A$	Ambient storage temperature	-45...+105	°C
$V_{CCMAX}$	Supply Voltage	7	V
$T_J$	Primary conductor temperature	110	°C
$I_{PMAX}$	Maximum primary current	$20 \times I_{PN}$	A
$V_{ESD}$	Electrostatic Discharge (ESD), Human Body Model (HBM)	4	kV
<b>m</b>	Mass	9	g

Prolonged exposure of the device to absolute maximum values may result in degraded performance. Exposure of the device to conditions in excess of values listed, for any period of time, may result in permanent damage.

### Isolation Parameters

Symbol	Parameter	Data	Units
$V_d$	RMS Voltage for AC insulation test, 50/60 Hz, 1 minute	4.3	kV
$V_W$	Impulse withstand voltage 1.2/50 us	8	kV
$D_{CREE}$	Creepage (primary to secondary)	7.5	mm
$D_{CLEA}$	Clearance (primary to secondary)	7.5	mm
$CTI$	Comparative Tracking Index (Group IIIa)	600	V

### Mechanical Properties

Symbol	Parameter	Material / Data	Comment
---	Case material	PA66	V0
---	Busbar / Jumper	Red Cu	Ni+Sn plating
---	Terminals	Brass	Ni+Au plating
---	Mass	8.52g	±10%

# Current Sensor

## CF1P023N

### Electrical Data

#### CF1P023N-S0075A

Unless otherwise noted:  $T_A=25^\circ\text{C}$ ,  $V_{CC}=5\text{V}$ ,  $R_L=10\text{k}\Omega$

Symbol	Parameter	Min.	Typ.	Max.	Units
$I_{PN}$	Primary nominal RMS current		75		A
$I_{PM}$	Maximum measuring range $T_A=25^\circ\text{C}$ , $V_{CC}=5\text{V}$ , $R_L=10\text{k}\Omega$	-220		220	A
$I_{PM}$	Maximum measuring range $T_A=85^\circ\text{C}$ , $V_{CC}=4.75\text{V}$ , $R_L=10\text{k}\Omega$	-180		180	A
$V_{CC}$	Supply voltage	4.75	5	5.25	V
$I_C$	Current consumption @ $I_P$		$\frac{19+I_P/N_S}{1000}$ $N_S = 966$	$\frac{25+I_P/N_S}{1000}$ $N_S = 966$	mA
$V_{ref}$	Internal reference voltage @ $I_P=0$	2.49	2.5	2.51	V
$V_{ref}$	External reference voltage	0		4	V
$V_{out}$	Output voltage range @ $I_P=0$ , $T_A=25^\circ\text{C}$		$V_{ref}$		V
$V_{OE}$	Offset voltage @ $I_P=0$ , $T_A=25^\circ\text{C}$	-1.0		1.0	mV $V_{out} - V_{ref}$
$G_{th}$	Sensitivity (theoretical)		6.25		mV $468.5\text{mV}/I_{PN}$
$E_G$	Sensitivity error @ $I_{PN}$	-0.7		0.7	%
$E_L$	Linearity error @ $I_{PN}$	-0.1		0.1	%
$TCV_{OUT}$	Temperature coefficient of $V_{OUT}@I_{PN}=0$			$\pm 4$	ppm/ $^\circ\text{C}$
$TCG$	Temperature coefficient of Gain			$\pm 40$	ppm/ $^\circ\text{C}$
$t_{ra}$	Reaction time @ 10% of $I_{PN}$			0.3	$\mu\text{s}$
$t_r$	Step response time @ 90% of $I_{PN}$			0.3	$\mu\text{s}$
$BW$	Frequency bandwidth (-3 db)	300			kHz
$V_{no}$	Output RMS noise Voltage (DC ~10kHz)		3		mVpp
	Output RMS noise Voltage (DC ~100kHz)		6		
	Output RMS noise Voltage (DC ~1MHz)		15		
---	Accuracy @ $I_{PN}$ , $+25^\circ\text{C}$			0.8	% of $I_{PN}$
	Accuracy @ $I_{PN}$ , $+85^\circ\text{C}$			1.1	
	Accuracy @ $I_{PN}$ , $+105^\circ\text{C}$			1.3	

# Current Sensor

## CF1P023N



### Current Sensor Dimensions (in mm)

#### CF1P023N

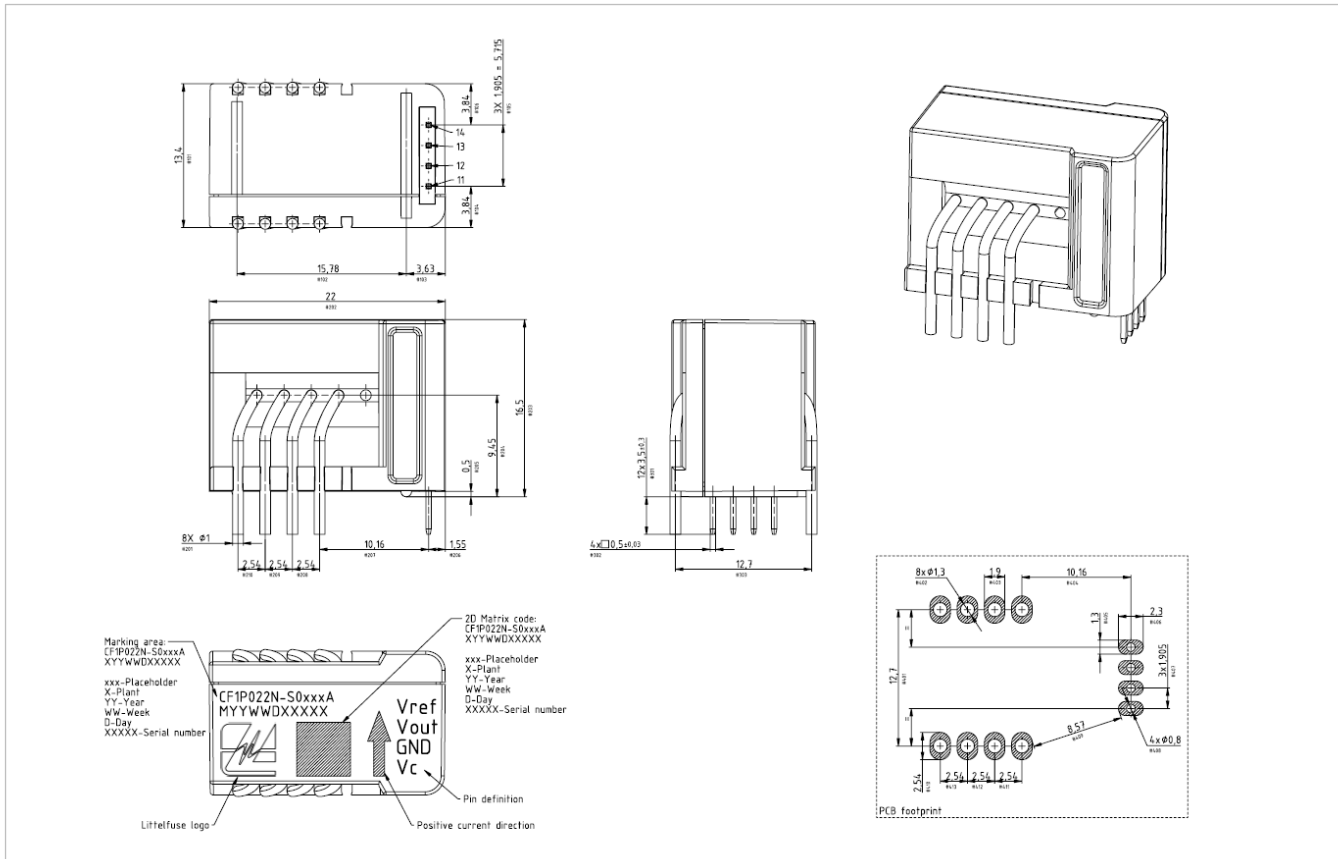

### Pinout

Primary Current Jumper Connections		
Pin	Sym.	Description
1	$I_P$	Primary current - IN
2	$I_P$	Primary current - IN
3	$I_P$	Primary current - IN
4	$I_P$	Primary current - IN
5	$I_P$	Primary current - IN
6	$I_P$	Primary current - OUT
7	$I_P$	Primary current - OUT
8	$I_P$	Primary current - OUT
9	$I_P$	Primary current - OUT
10	$I_P$	Primary current - OUT

Signal Connections		
Pin	Sym.	Description
11	$V_{ref}$	Reference Voltage
12	$V_{out}$	Output Voltage
13	GND	Ground
14	$V_{CC}$	Power supply Voltage

# Current Sensor

## CF1P023N

### Primary Current Application

Recommended jumper combinations to create multiple turns of primary current through the device.

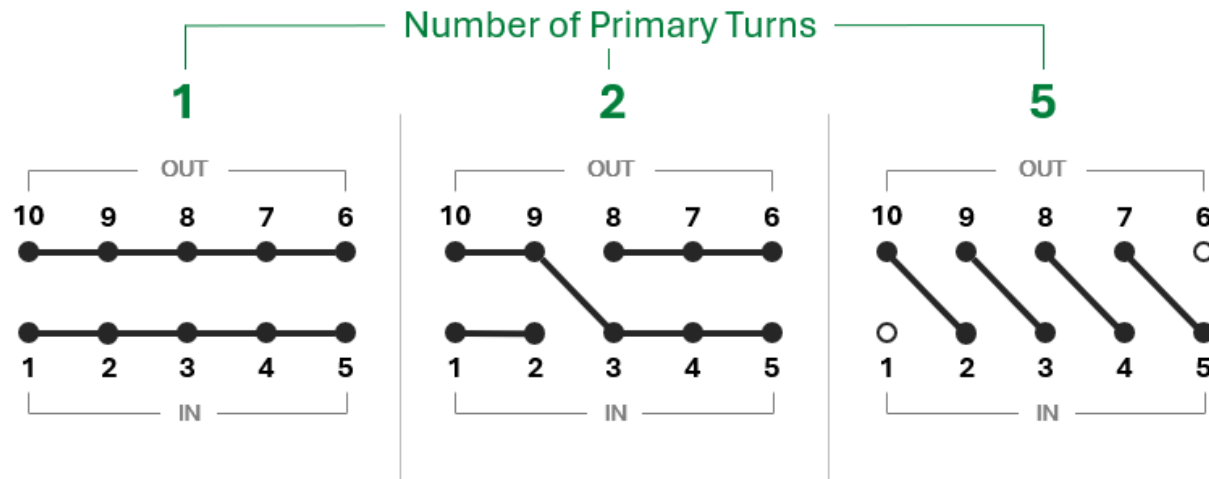

### Handling

- Handling of sensors should be minimized by maintaining parts within packaging until point of assembly.
- Contact with sensor terminals should be avoided.
- To avoid potential damage, adherence to ESD handling best practices is recommended.
- Dropped parts should be scrapped regardless of evidence of external damage.

# Current Sensor

## CF1P023N

### Contact

Custom electrical and environmental specifications can be designed to meet any need, please contact Littelfuse Engineering for details.

Website: [www.littelfuse.com](http://www.littelfuse.com)  
Sales Support: [ALL\\_Autosensors\\_Sales@littelfuse.com](mailto:ALL_Autosensors_Sales@littelfuse.com)  
Technical Support: [ALL\\_Autosensors\\_Tech@littelfuse.com](mailto:ALL_Autosensors_Tech@littelfuse.com)

**Disclaimer Notice** - Information furnished is believed to be accurate and reliable. However, users should independently evaluate the suitability of and test each product selected for their own applications. Littelfuse products are not designed for, and may not be used in, all applications. Read complete Disclaimer Notice at <https://www.littelfuse.com/legal/disclaimers/product-disclaimer>.

Information provided by Littelfuse is believed to be accurate and reliable.

All rights reserved. Trademarks and registered trademarks are the property of their respective owners.

Littelfuse products are designed for specific applications and should not be used for any purpose (including, without limitation, automotive applications) not expressly set forth in applicable Littelfuse product documentation. Warranties granted by Littelfuse shall be deemed void for products used for any purpose not expressly set forth in applicable Littelfuse product documentation. Littelfuse shall not be liable for any claims or damages arising out of products used in applications not expressly intended by Littelfuse as set forth in applicable Littelfuse product documentation.

Document version: Rev. 1.0

Date of print: 03SEP2025