

Current Sensor

CF1S011N



Description

The Littelfuse CF1S011N current sensor is a Fluxgate technology-based device offering a high accuracy, very low offset current measurement via CAN communication interface. The construction provides galvanic separation between the primary circuit (HV) and the secondary circuit (24V).

Applications

- Energy Storage
- Battery management system
- Battery junction box
- Battery Disconnect Unit
- Uninterruptible power supply

Standards

- EN 61010-1 :2010
- EN IEC 61326-1:2021

Features

- Fluxgate technology
- Operating temp. range: -40°C ...+85°C
- +24V DC unipolar power supply
- CAN communication
- Configurable CAN ID
- Current measurement: up to $\pm 1500A$
- Offset error < 50mA
- Total error <0.5% (over T°C range)
- Unlimited over-current capability

Benefits

- High sensing accuracy
- Low offset error
- HV Isolated current sensing
- Full galvanic separation

Mechanical Characteristics

- Case Material: PBT GF30-V0
- Mass: 100g $\pm 5\%$
- Terminals: Cu with Sn plating
- Protection degree: IP41 (IEC 60529)

Mating Connector Interface

- Tyco-AMP 4-Way; P/N 1473672-1

Current Sensor

CF1S011N

Littelfuse Current Sensor P/N Convention

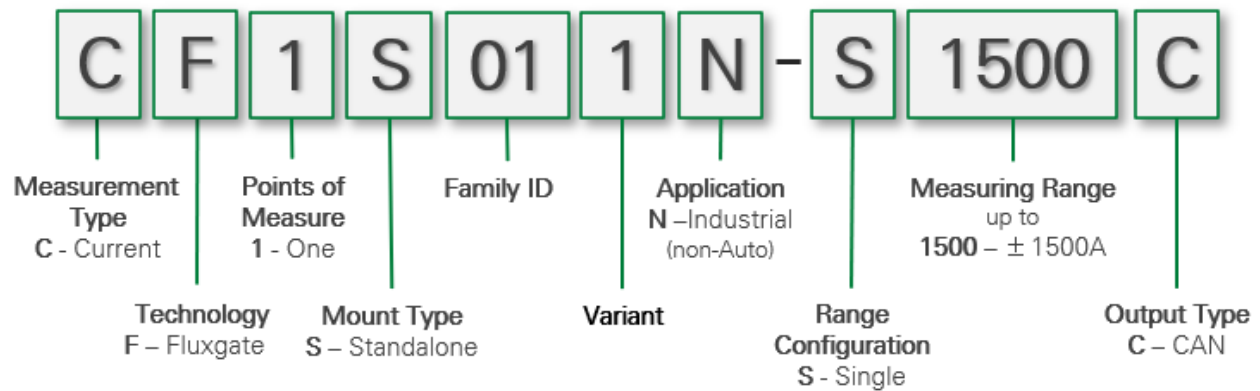

Product Identification

Part Name	Littelfuse Part Number	Nominal RMS Current
CF1S011N-S1500A	24940-00-02	±1500 A

Mechanical Product Properties

Parameter	Information	Comment
Case material	PA66-GF30	V0 per UL94
Terminals	Cu	Sn plating
Mounting nut	Brass	
Mass	90g	±5%
Ingress protection	IP41	

Current Sensor

CF1S011N

Current Sensor Dimensions (in mm)

CF1S011N

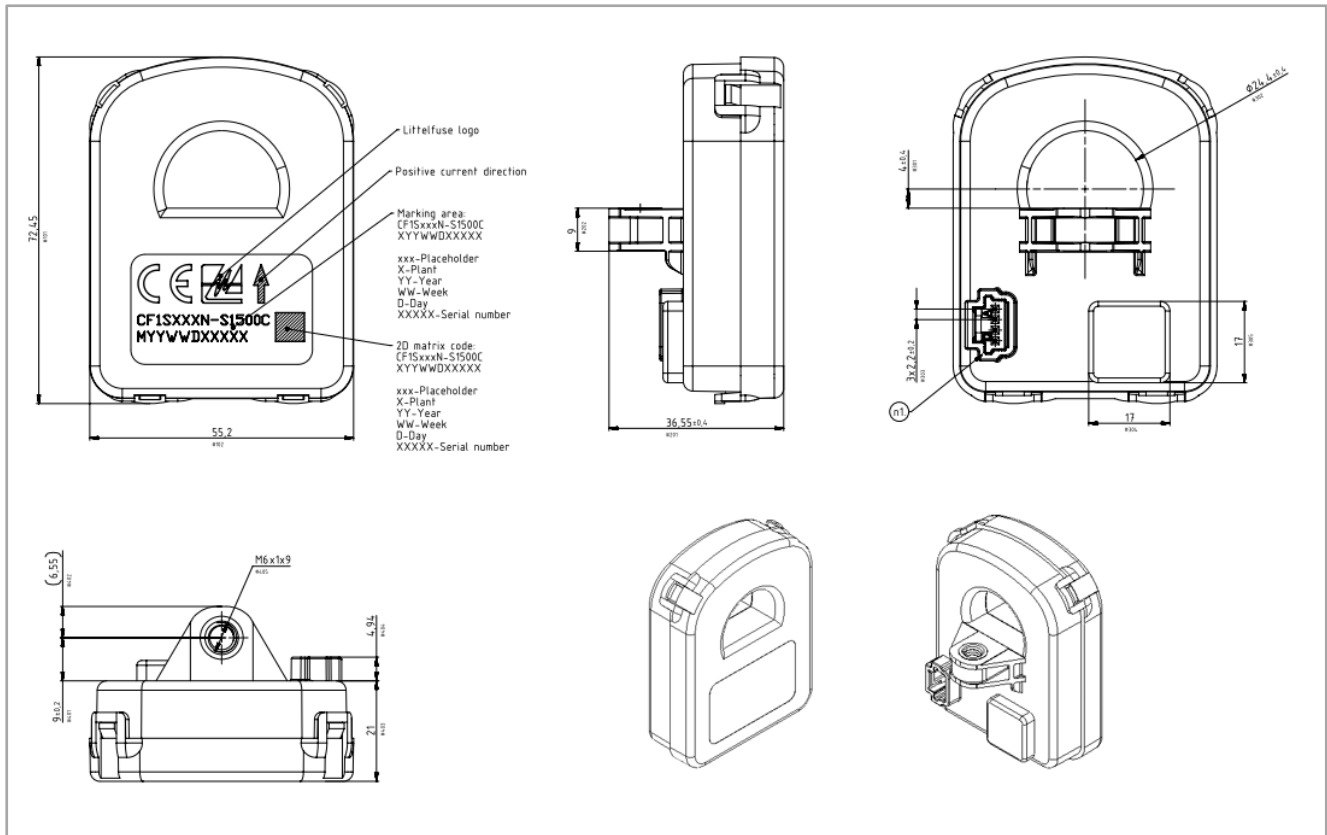

Mating Connector

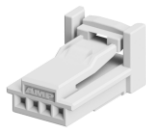

- TE / AMP 1473672-1
- 4 - Position Housing
 - 0.64/025 Connector System
 - 2.2 mm wire-to-wire spacing



- TE / AMP 1473672-1
- Terminal-Recept., 24-20 AWG
 - 0.64/025 Connector System

Pinout

Pin No.	Signal	Description
A	CANL	CAN-L bus output
B	CANH	CAN-H bus output
C	GND	Ground / DC negative input
D	VCC	+12VDC power supply

Current Sensor

CF1S011N

Absolute Maximum Ratings

Parameter	Symbol	Value	Units	Comments
Load-dump overvoltage	V_{CC}	45	V	Max. 350ms
Over-voltage	V_{CC}	36	V	Max. 1 min.
Reverse polarity	V_{CC}	-36	V	Max. 1 min.
Minimum supply Voltage	V_{CCMIN}	14	V	Continuous, non-operating
Maximum supply Voltage	V_{CCMAX}	34	V	Continuous, non-operating
RMS Voltage-AC insulation test	V_d	2.5	kV	%50 Hz, 1 minute
Insulation resistance	R_{INS}	500	M Ω	500V – ISO 16750-2
Creepage	D_{CREE}	14	mm	
Clearance	D_{CLEA}	13	mm	
Storage Temperature	T_{ST}	-40... +105	°C	

Prolonged exposure of the device to absolute maximum values may result in degraded performance. Exposure of the device to conditions in excess of values listed, for any period of time, may result in permanent damage.

Common Characteristics (nominal range)

Parameter	Symbol	Min.	Typ.	Max.	Units	Comments
Operating Ambient Temperature	I_{C_OP}	-40		+85	°C	
Primary nominal DC current	I_{PN}	-1500		1500	A	Clamped @ $\pm 1550A$
Peak withstand current (max.)	I_{PM}	-1700		1700	A	
Supply Voltage	V_{CC}	16	24	32	V	
Current consumption @Ip=0A	I_{C_OP}	28	33	40	mA	8V < VCC < 16V
Current consumption @Ip=1500A	I_{C_OP}	180	280	500	mA	8V < VCC < 16V
CAN Output frequency			100		Hz	With periodic CAN message @10ms
Power-on Time	t_{on}		170		ms	Excluding 20ms for HW initialization check
Overload recovery time			30		ms	IP returns to below 1550A
Frequency bandwidth	BW		10		Hz	With periodic CAM message at 10ms
Linearity error	ϵ_L		± 0.1		%	@25°C

Current Sensor

CF1S011N

Digital Signal

Parameter	Symbol	Min.	Typ.	Max.	Units	Comment
CAN Protocol Type		CAN 2.0 A/B				
CAN Frame Type		Standard (11bit ID)				
CAN Message Period	T_{CAN}		10		ms	
CAN Baud Rate	F_{CAN}		500		kbps	
Current signal Resolution			1		mA	per LSB
CAN Byte Order		Motorola (Big-endian)				
CAN Message ID	ID_{CAN}	0x3BF				
CAN Termination		120			Ω	Termination resistor to be added externally
CAN Data ID	ID	0xF3CE				Customer selectable

Current Sensor

CF1S011N

CAN Bit Table

Byte number	Bit number							
	Bit7	Bit6	Bit5	Bit4	Bit3	Bit2	Bit1	Bit0
Byte0	7	6	5	4	3	2	1	0
	Sequence Counter Ip				Status Power Supply		Status Internal Error	Reserved
	MSB			LSB	MSB	LSB		
Byte1	15	14	13	12	11	10	9	8
	Analog Current							
	MSB							
Byte2	23	22	21	20	19	18	17	16
	Analog Current							
Byte3	31	30	29	28	27	26	25	24
	Analog Current							
								LSB
Byte4	39	38	37	36	35	34	33	32
	Reserved							
	MSB							LSB
Byte5	47	46	45	44	43	42	41	40
	Reserved							
	MSB							LSB
Byte6	55	54	53	52	51	50	49	48
	Reserved							
	MSB							LSB
Byte7	63	62	61	60	59	58	57	56
	CRC							
	MSB							LSB

Current Sensor

CF1S011N

CAN Frame Explanation – Byte 0

- **“Sequence Counter Ip” signal**
 1. Initialized with 0 and incremented by 1 for every subsequent send request
 2. When the counter reaches the value 15 (0xF), it then restarts with 1 for the next send request
- **“Status Power Supply” signal” signal**

CAN Frame Content								
Byte number	Bit7	Bit6	Bit5	Bit4	Bit3	Bit2	Bit1	Bit0
	7	6	5	4	3	2	1	0
Byte0	Sequence Counter Ip				Status Power Supply		Status Internal Error	Reserved
	MSB			LSB	MSB	LSB		

- When Power Supply Voltage measurement is not available, then Status Power Supply” = “1 1”
Note: At sensor start-up; If power supply Voltage is <15.8V or, >32.2V there is no CAN frame emission.

- **“Status Internal Error” signal**

Over-current detected in the busbar (current greater than 1600A): In such case the “Status Internal Error” flag is set to “1”.

CAN Output Transfer Function (Bytes 1, 2 and 3)

Primary Current	HEX Value	MSB	LSB	
		Byte 1	Byte 2	Byte 3
1550	97A6B0	97	A6	B0
1500	96E360	96	E3	60
0.001	800001	80	00	01
0	800000	80	00	00
-0.001	7FFFFFFF	7F	FF	FF
-1500	691CA0	69	1C	A0
-1550	685950	68	59	50

- **CRC Signal**
8-bit SAE J1850 CRC calculation of the first 7 bytes

Current Sensor

CF1S011N

Total Error

Analog Channel – Total error from -40°C to 85°C, ± 3 Sigma

Performance averaged over (20) CAN frames (200 ms)

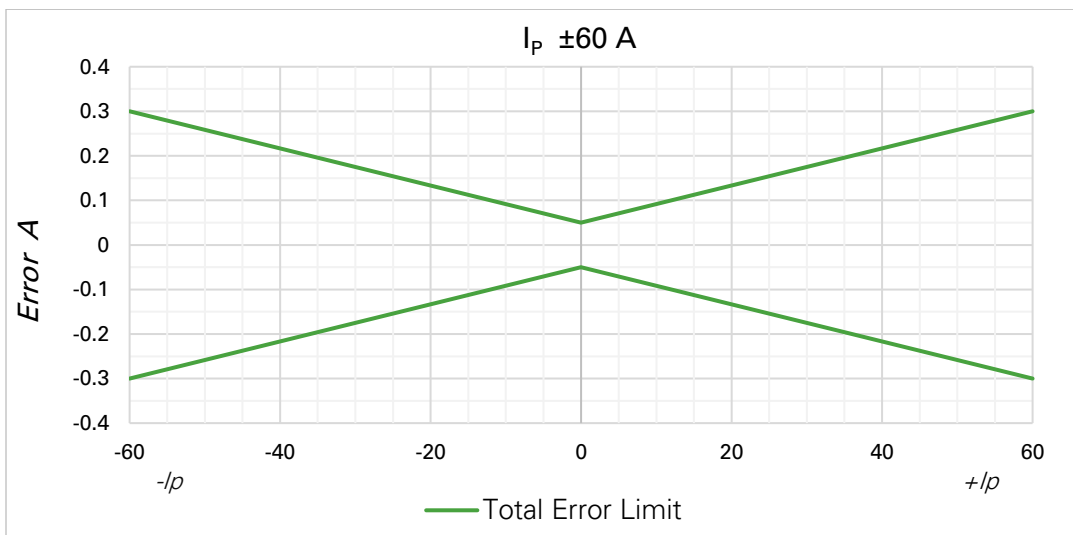
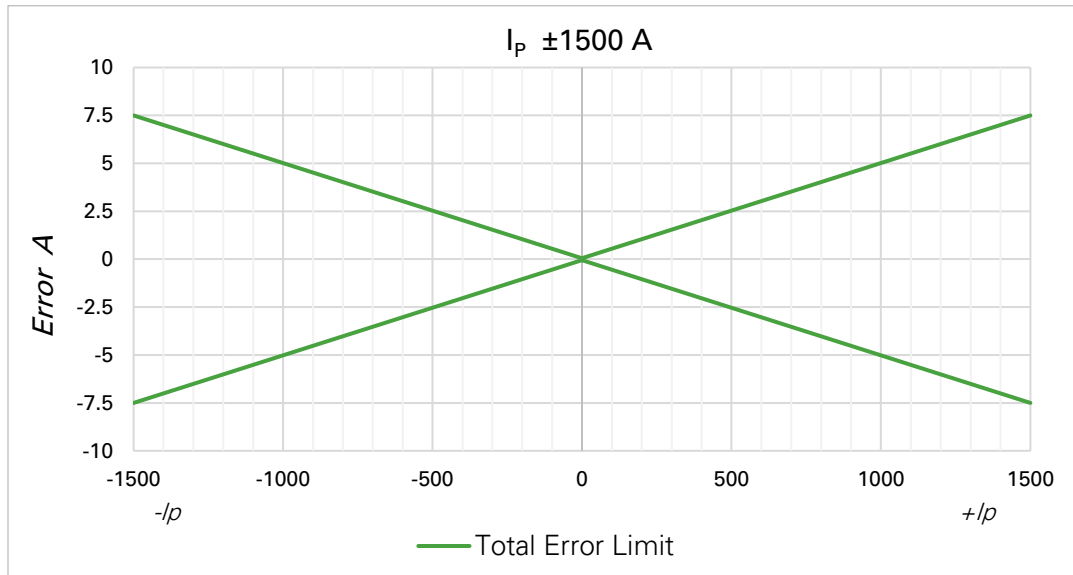

Primary Current $\pm I_p$	Total Error (16V \leq Vcc \leq 32V; -40°C < Ta < 85°C; ± 3 Sigma)	
	A	%
+1500 A	± 7.5	± 0.5
+60	± 0.3	± 0.5
0	± 0.05	-
-60	± 0.3	± 0.5
-1500 A	± 7.5	± 0.5

Current Sensor

CF1S011N

Recommendations for Use

Setup Recommendation

Busbar Mounting:



- Mount with ISO M6 serrated flange screw or bolt, or with M6 fastener screw or bolt combined with lock washer.
- Assembly torque: 6.6 N·m \pm 10%
- It is recommended to pre-tighten mounting fasteners prior to applying final assembly torque.
- Recommended mating busbar cross section: 4 x 22 mm

Busbar Routing:



- To assure stated accuracy it is recommended that the busbar design allows for the bus bar to be straight for a distance of:
 - \geq 10 mm beyond sensor face (opposite mounting feature)
 - \geq 20 mm beyond sensor mounting feature.
- Busbar layout should be reviewed with Littelfuse application engineering for compatibility.

Handling

- Handling of sensors should be minimized by maintaining parts within packaging until point of assembly.
- Contact with sensor terminals should be avoided.
- To avoid potential damage, adherence to ESD handling best practices is recommended.
- Dropped parts should be scrapped regardless of evidence of external damage.

Current Sensor

CF1S011N

Performance Parameter Definitions

Typical minimum and maximum values

Typical, minimum, and maximum values get determined during initial product characterization. Typical values representing the normal of statistical $\pm 1\sigma$ interval (68.27% probability).

Minimum and maximum values representing the Gaussian distribution boundaries of the $\pm 3\sigma$ interval (99.73% probability).

Primary current definition (I_N, I_p)

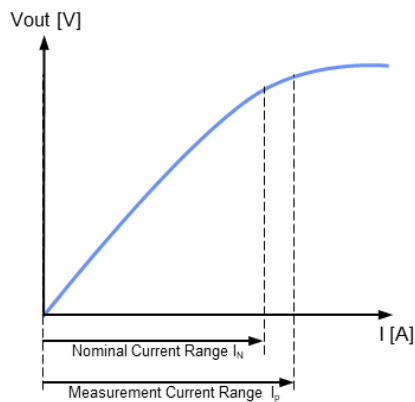

Sensitivity error (ϵ_S)

The sensor sensitivity error is the drift of sensor's ideal sensitivity.

$$\epsilon_S = \pm \frac{S - S_{th}}{S_{th}} \times 100\%$$

S_{th} : theory sensitivity

Power-on time (t_{PO})

The Power-on time is the duration from U_c (min.) to 90% of V_{out} .

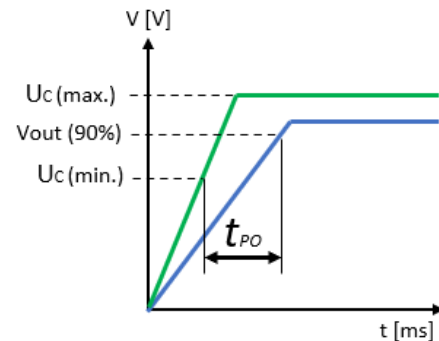

Response time (t_r)

The time between the primary current signal and the output signal reaching at 90% of its final value.

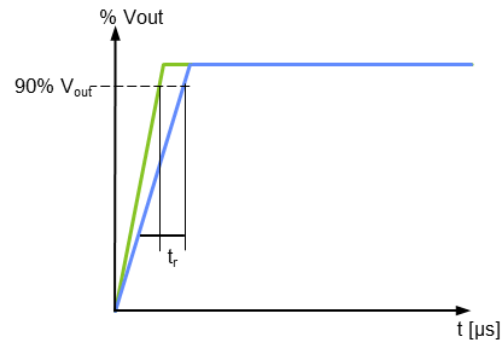

Current Sensor

CF1S011N

Contact

Custom electrical and environmental specifications can be designed to meet any need, please contact Littelfuse Engineering for details.

Website: www.littelfuse.com
Sales Support: ALL_Autosensors_Sales@littelfuse.com
Technical Support: ALL_Autosensors_Tech@littelfuse.com

Disclaimer Notice - Information furnished is believed to be accurate and reliable. However, users should independently evaluate the suitability of and test each product selected for their own applications. Littelfuse products are not designed for, and may not be used in, all applications. Read complete Disclaimer Notice at: <https://www.littelfuse.com/legal/disclaimers/product-disclaimer>.

Datasheet subject to change without notice.

Information provided by Littelfuse is believed to be accurate and reliable.
All rights reserved. Trademarks and registered trademarks are the property of their respective owners.
Littelfuse products are designed for specific applications and should not be used for any purpose (including, without limitation, automotive applications) not expressly set forth in applicable Littelfuse product documentation. Warranties granted by Littelfuse shall be deemed void for products used for any purpose not expressly set forth in applicable Littelfuse product documentation. Littelfuse shall not be liable for any claims or damages arising out of products used in applications not expressly intended by Littelfuse as set forth in applicable Littelfuse product documentation.

Document version: [Rev. 1.2](#)
Date of print: [11SEP2025](#)