

DCNEV Series

High Current High Voltage DC Contactor Relay

OBSOLETE: June, 2025



Description

High current and high voltage DC contactor relays for electric vehicle applications such as charging station, battery power supply, DC power control, circuit protection, and other switch controls. Can also be used in uninterruptible power supply and other electronic control systems. Are available with polarized and non-polarized contacts to best suit electrical systems' polarity. The Coil Economizer greatly reduces coil power and heating after the contactor is energized. Once the contactor is energized, it takes minimal coil power to keep the contacts closed due to Pulse Width Modulation (PWM) reducing the average power delivered by pulsing the electrical signal.

Web Resources

Download 2D print and technical resources at:
littelfuse.com/DCNEV250



Specifications Overview

| | |
|---------------------------------|--|
| Amperage: | 250A Continuous Carry |
| Housing: | Nylon UL 94-V0 |
| Voltage Rating: | 900V |
| Output Connectors: | M8 x 1.25 High Current Connections |
| Connectors: | Wire Leads for Control Circuit |
| Ingress Protections: | IP67 |
| Operating Temperature: | -40°C to 85°C |
| Circuitry: | SPST NO |
| Coil Voltage: | M: 12-24V DC Nominal, 9-36V DC Working F: 72V DC Nominal, 48-95V DC Working G: 48-72V DC Nominal, 32-95V DC Working |
| Max Coil Inrush Current: | 0.7-3.8A |
| Mounting: | #10 with Compression Limiters |
| Size: | Reference Dimensions on Page 2 |
| Mounting Bolt Torque: | 1.7-3.3 Nm (15-30 in-lb) |
| Contact Torque: | 8.8-11 Nm (80-100 in-lb) |
| Terminals: | M8 Silver Plated Copper |
| Approvals: | UL File No. E510407 Recognized |

Features and Benefits

- High current (250A) and high voltage (900V) contactor for EV applications
- Compact structure, helping reduce noise when turned on
- Coil Economizer greatly reduces coil power and heating
- Sealed IP67, gas-filled relay which mitigates arcing
- No mounting orientation restrictions
- Designed and manufactured under the IATF16949 certification for Automotive Quality Systems.
- Designed specifically for automotive applications.

Applications

- Battery Electric Vehicles
- Hybrid Electric Vehicles
- Material Handling
- Electric Maintenance and Transport Vehicles
- Industrial Applications

DCNEV Series

High Current High Voltage DC Contactor Relay

Ordering Information

| PART NUMBER | DESCRIPTION | COIL VOLTAGE 12-24V DC | COIL VOLTAGE 72V DC | COIL VOLTAGE 48-72 VDC | BOTTOM MOUNT | AUXILIARY CONTACT SPST-NO | AUXILIARY CONTACT SPST-NC | NON-POLARIZED TERMINALS | POTTED PCB |
|-------------|---|------------------------|---------------------|------------------------|--------------|---------------------------|---------------------------|-------------------------|------------|
| DCNEV250-M | High Voltage DC Contactor Relay Bottom Mount with Polar Load Terminals | ● | | | ● | | | | |
| DCNEV250-MA | High Voltage DC Contactor Relay Bottom Mount with Auxiliary Circuit with Polar Load Terminals | ● | | | ● | ● | | | |
| DCNEV250-MP | High Voltage DC Contactor Relay Bottom Mount with Potted PCB with Polar Load Terminals | ● | | | ● | | | | ● |
| DCNEV250-MB | High Voltage DC Contactor Relay Bottom Mount with Auxiliary Circuit with Polar Load Terminals | ● | | | ● | | ● | | |
| DCNEV250-F | High Voltage DC Contactor Relay Bottom Mount with Polar Load Terminals | | ● | | ● | | | | |
| DCNEV250-FA | High Voltage DC Contactor Relay Bottom Mount with Auxiliary Circuit with Polar Load Terminals | | ● | | ● | ● | | | |
| DCNEV250-FB | High Voltage DC Contactor Relay Bottom Mount with Auxiliary Circuit with Polar Load Terminals | | ● | | ● | | ● | | |
| DCNEV250-G | High Voltage DC Contactor Relay Bottom Mount with Polar Load Terminals | | | ● | ● | | | | |
| DCNEV250-GA | High Voltage DC Contactor Relay Bottom Mount with Auxiliary Circuit with Polar Load Terminals | | | ● | ● | ● | | | |

* Box Packaging Available

DCNEV Series

High Current High Voltage DC Contactor Relay

Dimensions in MM

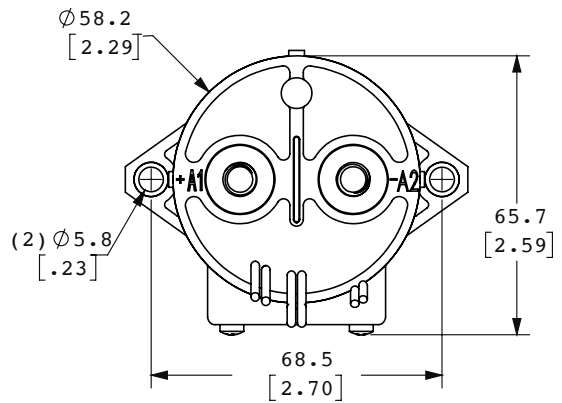
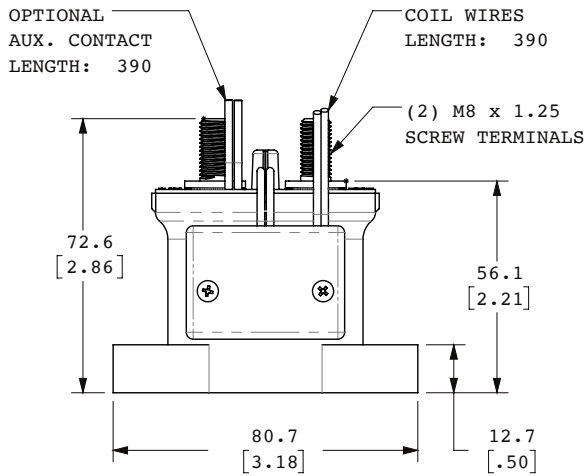

Electrical Load Life Ratings for Typical EV Applications

MAKE/BREAK LIFE CAPACITIVE & RESISTIVE LOADS AT 320VDC*1

| | |
|--|---------------|
| @90% pre-charge (make only), see chart below | 50,000 cycles |
| @Min 80% pre-charge (make only), see chart below | 50 cycles |

*1: Resistive load includes L=25uH. Load @2500A, test @200uH

Estimated Make Break Chart

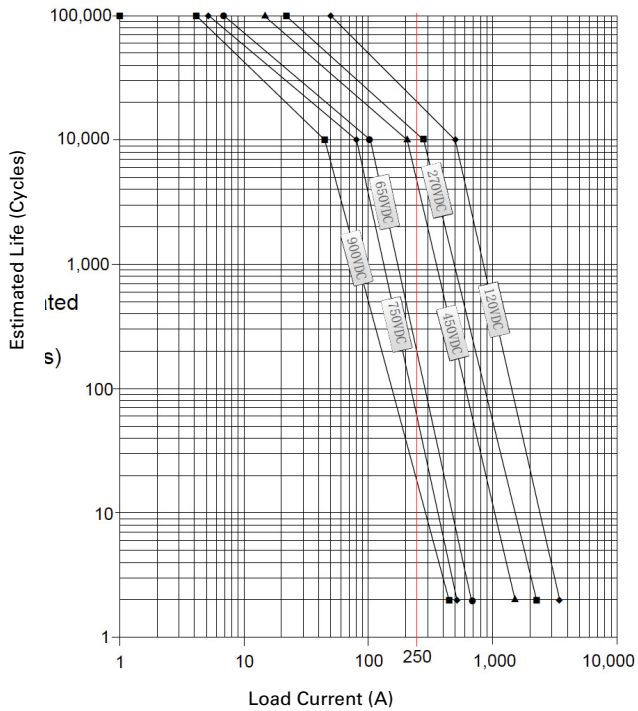

Capacitive Make Test Curve

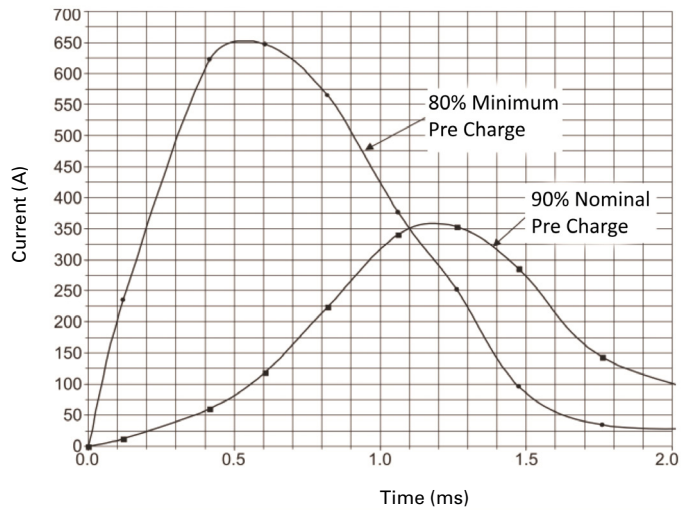

Electrical Diagram

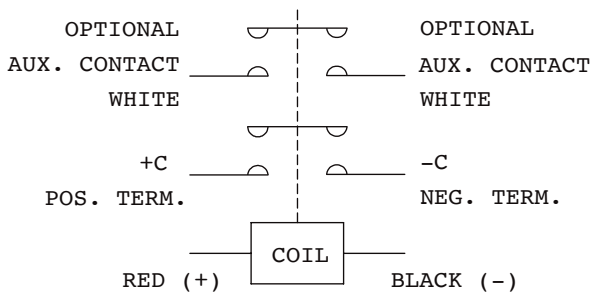

Estimated Electrical Life

| | POLARITY SENSITIVE TYPE | | NON-POLARITY SENSITIVE TYPE | |
|---------------|-------------------------|-----|-----------------------------|--------|
| Voltage (V) | 450 | 650 | 650 | 450 |
| Current(A) | 250 | 250 | 100 | 100 |
| Life (cycles) | 5,000 | 500 | 1,000 | 10,000 |

Note:

Estimates based on extrapolated data. User is encouraged to confirm performance in application.

DCNEV Series

High Current High Voltage DC Contactor Relay

Performance Data

| MAIN CONTACT | |
|---------------------------------|--|
| Contact arrangement | 1 Form X (SPST-NO, DM) |
| Rated Operating Voltage | 12-900VDC |
| Continuous (Carry) Current | 250A (65°C) *2 |
| Max short circuit current | 2,000A @320VDC, 1 cycle*1 |
| Dielectric Withstanding Voltage | 2,200Vrms (leakage <1mA) |
| Insulation Resistance | Terminal to Terminal/Terminal to coil New: Min 100 MΩ @500Vdc End of life: Min 50 MΩ @500Vdc |
| Voltage Drop (@250A) | ≤50mV |

1: Does not meet dielectric & IR after test.
2: Higher currents are possible but are relevant to cross-sectional area of conductor.

| COIL DATA | | | |
|------------------------|------------------------------|-------------|-------------|
| Coil Voltage | 12 - 24Vdc | 72Vdc | 48 - 72Vdc |
| Voltage (Max.) | 36Vdc | 95Vdc | 95Vdc |
| Pickup voltage (Max.) | 9Vdc | 48Vdc | 32Vdc |
| Dropout voltage (Min.) | 6Vdc | 27Vdc | 18Vdc |
| Inrush Current (Max.) | 3.8A | 0.7A | 1.3A |
| Holding Current (Avg.) | 0.13A@12Vdc / 0.07A@24Vdc | 0.02A@72Vdc | 0.03A@48Vdc |

| MAX. BREAKING LIMIT | MAX. SHORT CIRCUIT |
|--------------------------|--------------------|
| 2,000A @ 320VDC, 1 cycle | 3,000A, 1 sec |

Current vs Time Curve

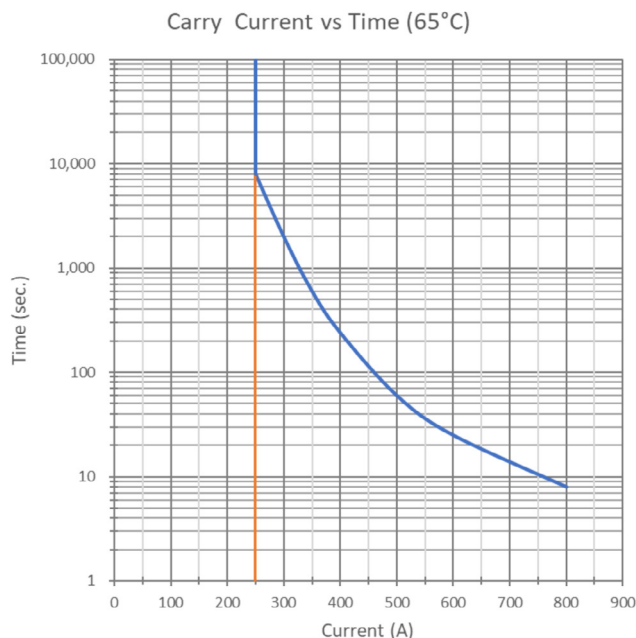

Copper Conductor: 75mm²

| LIFE | |
|---------------------|--------------------------------|
| Resistive load life | See estimated make break chart |
| Mechanical life | 200,000 cycles |

| OPERATE / RELEASE TIME | |
|-------------------------|------------|
| Close (includes bounce) | 25ms, Max. |
| Release | 12ms, Max. |

| ENVIRONMENTAL DATA | |
|-------------------------------|-------------------|
| Shock, 11ms ½ sine, operating | 20G Peak |
| Vibration, Sine, Peak, 20G | 80—2,000Hz |
| Operating Ambient Temperature | -40 to +85°C |
| Weight | 0.95 Lb (0.43 kg) |
| Altitude | <4000m |

| AUX. CONTACT | |
|--------------------------|-------------------------------|
| Aux. Contact Arrangement | 1 Form A, 1 Form B |
| Aux. Contact Current Max | 2A@30VDC/ 3A@125VAC |
| Aux. Contact Current Min | 100mA@8V |
| Max. Contact Resistance | 0.417Ω@30VDC 0.150Ω@125VAC |

Application Note:

- Be sure to use washer to prevent screws from loosening. Tighten the screw torque range is specified as below. Exceeding the maximum torque can lead to product rupture.
 - Contact torque (M8): 80 - 100 lb.in (8.8 - 11 N.m)
 - Mounting torque: 15 - 30 lb.in (1.7 - 3.3 N.m)
- Please refer to drawing for polarity sensitive type during connecting; No orientation for non-polar type.
- Do not use dropped products.
- Avoid to install the product in a strong magnetic field (Close to the transformer or magnet), or near an object with heat radiation.
- Electrical life
Please use under load capability and life cycle so as not to cause a function failure. (Please also treat the contactor as a product with specified life and replace it when necessary). It is possible to make parts burn around the contactor once operating failure happens. So it is necessary to take layout into account to make sure power shall be cut off within 1 second.
- Lifetime of internal gas diffusion
The contactor is sealed and filled with gas, lifetime of gas diffusion is determined by temperature in contact chamber (Ambient temperature + Temperature rising by contact energizing). Therefore environment temperature should be from -40 to +85°C.
- Do not let particle and oil stain on the main terminal with which the load shall make a reliable contact. Or it will cause a lot of heat.