

527 Series

Lead-free > 6x32mm Fuse



Description

Littelfuse 527 series fuse is specifically designed and tested to the circuit protection needs of compact auto electronics applications, which is 500 Vac rated with remarkable interrupting rating.

Features & Benefits

- RoHS compliant and Lead-free
- High current
- High Interrupt Rating
- High voltage
- Small size
- High breaking capacity

Applications

- On-Board Charger (OBC)

Additional Information



Resources



Accessories



Samples

Agency Approvals

Agency	Agency File Number	Ampere Range
cULUS	E10480	30 A - 50 A

Electrical Characteristics

% of Ampere Rating	Ampere Rating	Opening Time at 25°C
100%	30 A - 50 A	4 hours, Min.
135%	30 A - 40 A	60 minutes, Max.
200%	30 A - 50 A	120 seconds, Max.

Electrical Specifications

Ampere Rating (A)	Amp Code	Max Voltage Rating (V)	Interrupting Rating (AC/DC)	Nominal Code Resistance (Ohm)	Nominal Melting I ² t (A ² sec)	Agency Approvals
						cULUS
30	030.	500VAC	10kA@500VAC*	0.0028	700	x
40	040.			0.0020	1090	x
50	050.	305VAC	10kA@305VAC	0.0014	2460	x

Note

* 10kA@500VDC also available for 30 A rating with minimum 200% fusing current @500VDC. Unless otherwise stated, all specifications are referenced at room ambient temperature.

527 Series

Lead-free > 6x32mm Fuse

Temperature Re-rating Curve

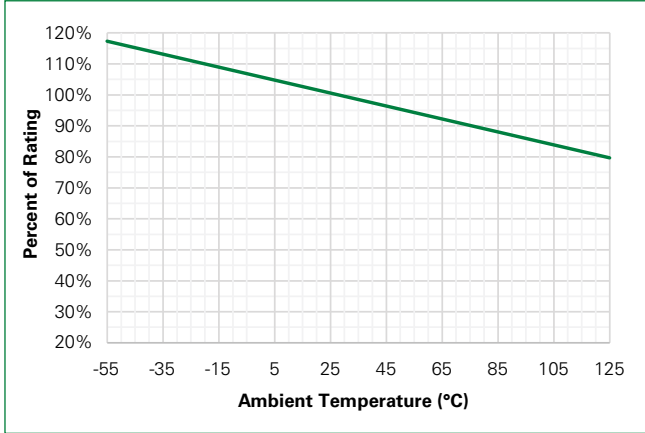

Note:
Derating depicted in this curve is in addition to the standard derating of 25% for continuous operation.

Average Time Current Curves

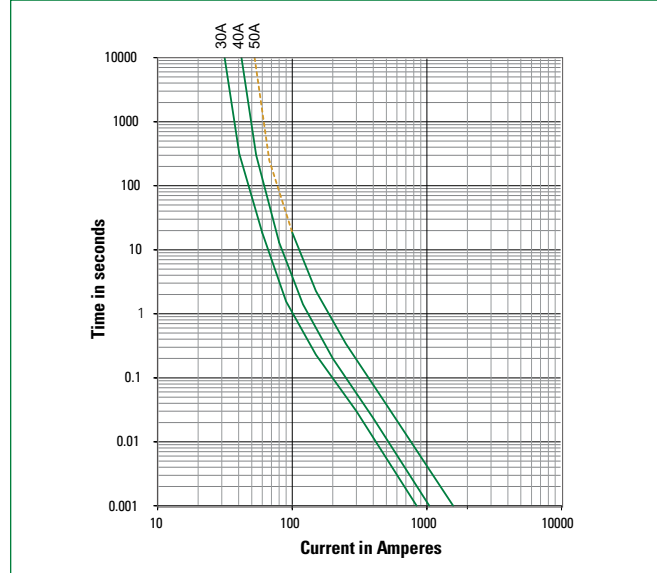

Note:
For 50 A rating, it may not break current consistently when overload current is less than 200% I_n (represented by dotted portion of this Time Current Curve), as may be arc current continuously pass through fuse under this condition. Not recommended for conditions requiring overloads of below 200% I_n.

Product Characteristics

Materials	Body: Glass fiber Cap: Ni plated copper alloy Terminal: Tin plated copper alloy
Mechanical Shock	MIL-STD-202, Method 213, Test Condition I (100 G's peak for 6 milliseconds)
Solderability	Reference MIL-STD-202 method 208
Product Marking	Cap 1: Brand logo, current and voltage ratings Cap 2: Agency approval marks
Resistance to Solder Heat	MIL-Std 202 Method 210 Test Condition B (10 sec at 260 °C)
Operating Temperature	-55 °C to +125 °C
Thermal Shock	MIL-STD-202G, Method 107G, Test condition B
Vibration	MIL-STD-202G, Method 201A
Moisture Resistance	MIL-STD-202G, Method 103B, Test condition A
Salt Spray	MIL-STD-202G, Method 101E, Test condition B

Soldering Parameters—Wave Soldering

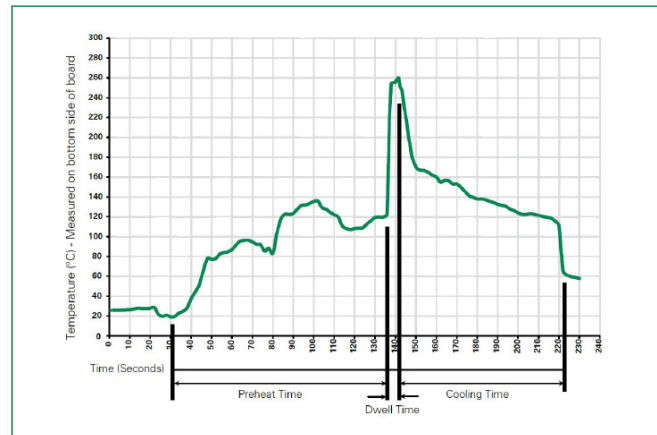

Wave Parameter	Lead-Free Recommendation
Preheat: (Depends on Flex Activation Temperature)	(Typical Industry Recommendation)
Temperature Minimum	100 °C
Temperature Maximum	150 °C
Preheat Time	60–180 seconds
Solder Pot Temperature	260 °C Maximum
Solder Dwell Time	2–5 seconds

Recommended Hand-Solder Parameters:

Solder Iron Temperature: 350 °C +/- 5 °C
Heating Time: 5 seconds max.

Note: These devices are not recommended for IR or Convection Reflow process.

527 Series

Lead-free > 6x32mm Fuse

Dimensions
Unit: mm

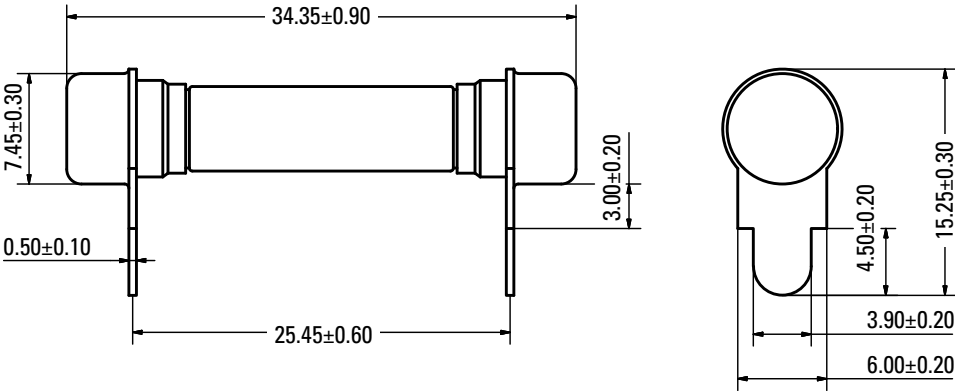

Part Numbering System

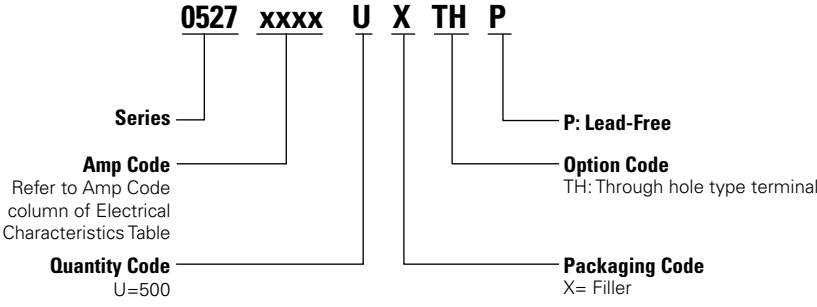

Packaging

Packaging Option	Packaging Specification	Quantity	Quantity & Packaging Code	Reel Size
527 Through hole terminal				
Tray	NA	500	NA	NA

Disclaimer Notice - Information furnished is believed to be accurate and reliable. However, users should independently evaluate the suitability of and test each product selected for their own applications. Littelfuse products are not designed for, and may not be used in, all applications. Read complete Disclaimer Notice at <http://www.littelfuse.com/disclaimer-electronics>.