

Parameter	Rating	Units
Blocking Voltage	60	V _P
Load Current	300	mA _{rms} /mA _{DC}
	600	mA _{DC}
On-Resistance (max)	5.6	Ω
Input Control Current	1.1	mA

Features

- Fast Turn-On:
 - 100μs max with recommended values of C_{EXT}
 - 250μs max with no C_{EXT}
- Active Current Limiting
- Thermal Shutdown
- 1.1mA Input Control Current
- Linear AC or DC Operation
- High Surge Capability
- Low Power Consumption
- Clean, Bounce-Free Switching
- Surface Mount Version Available
- Tape & Reel Packaging Available

Applications

- Security
- Instrumentation
- Battery Powered Systems
- Transportation, Railroad Controls
- 12V, 24V Systems

Approvals

- UL 508 Recognized Component: File E69938

Description

The CPC1560 is a Single Pole, Normally Open (1-Form-A) optically isolated MOSFET switch that provides fast turn-on of loads up to 600mA_{DC} in the DC-Only configuration or 300mA_{rms} in the AC/DC configuration; active current-limiting circuitry; and 3750V_{rms} of input to output isolation.

Turn-on is minimized with the use of an optional external storage capacitor that provides the necessary charge required by the internal switching MOSFETs. The device charges this capacitor through bootstrap diodes from the load voltage thereby alleviating the need for an additional power supply. A fast, but slightly slower turn-on is available without the external charge storage capacitor.

The CPC1560 incorporates current limiting and thermal shutdown circuitry for improved survivability in harsh environments and is designed to pass regulatory voltage surge requirements when provided with appropriate over-voltage protection.

Designed specifically for environmentally demanding AC and DC applications where printed circuit board space is at a premium and additional power supplies are not available, the CPC1560 is an ideal solution.

Ordering Information

Part	Description
CPC1560G	8-Pin, DIP Through-Hole (50/Tube)
CPC1560GS	8-Pin, Surface Mount (50/Tube)
CPC1560GSTR	8-Pin, Surface Mount (1000/Reel)

Figure 1. CPC1560 Block Diagram

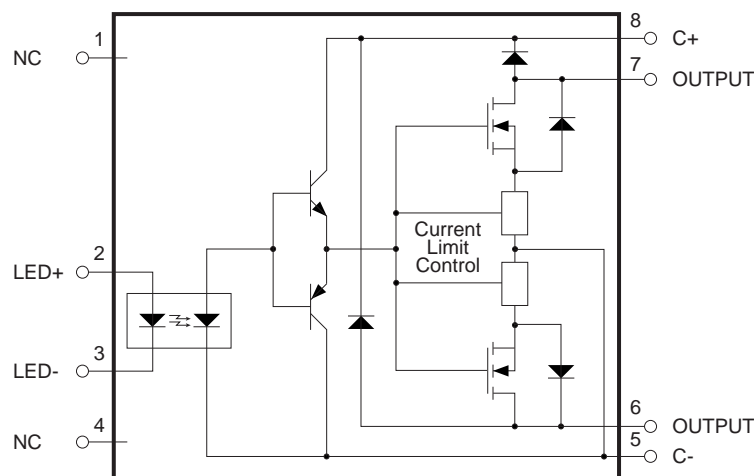

1. Specifications	3
1.1 Package Pinout	3
1.2 Pin Description	3
1.3 Absolute Maximum Ratings	3
1.4 ESD Rating	3
1.5 Recommended Operating Conditions	4
1.6 Typical Configurations	4
1.6.1 DC-Only Application	4
1.7 General Conditions	5
1.8 Electrical Specifications	5
1.9 Switching Speed Test Circuits	5
1.10 Performance Data	6
2. Introduction	8
3. Functional Description	8
4. Device Configuration	8
4.1 LED Resistor	8
4.2 Storage Capacitor	9
5. Operational Behavior	9
5.1 Operating Frequency	9
5.1.1 Duty Cycle/Power Dissipation	9
5.1.2 Temperature Effects	9
5.1.3 Elements of Operating Frequency	9
5.2 Switching Losses	9
5.2.1 Effects of Ambient Temperature	10
5.3 Current Limit and Thermal Shutdown	10
5.3.1 Current Limit	10
5.3.2 Thermal Shutdown	10
5.4 dV/dt Fault Tolerance	10
5.5 Power Derating	10
5.6 Rise and Fall Times	11
5.7 Over-Voltage Protection	11
5.7.1 Stored Energy in the Load	11
5.7.2 Protection Methods	12
6. Manufacturing Information	13
6.1 Moisture Sensitivity	13
6.2 ESD Sensitivity	13
6.3 Soldering Profile	13
6.4 Board Wash	13
6.5 Mechanical Dimensions	14

1. Specifications

1.1 Package Pinout

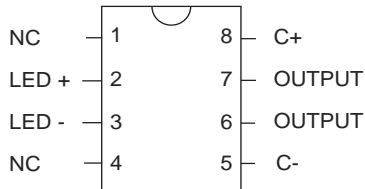

1.2 Pin Description

Pin#	Name	Description
1	NC	Not connected, no internal connection
2	LED +	Positive input to LED
3	LED -	Negative input to LED
4	NC	Not connected, no internal connection
5	C-	External Capacitor, Negative Terminal
6	OUTPUT	Switch Output
7	OUTPUT	Switch Output
8	C+	External Capacitor, Positive Terminal

1.3 Absolute Maximum Ratings

Parameter	Rating	Units
Blocking Voltage (V_L)	60	V_P
Reverse Input Voltage	5	V
Input LED Current		
Continuous	50	mA
Peak (10ms)	1	A
Input Control Current ¹	10	mA
Peak Turn-On Energy Dissipation		
AC/DC Configuration (85°C)	0.67	mJ
DC-Only Configuration (85°C)	1.34	
dV/dt Fault Tolerance		
AC/DC Configuration	160	$V/\mu s$
DC-Only Configuration	80	
Input Power Dissipation ²	150	mW
Output Power Dissipation ³	787	mW
Total Power Dissipation	800	mW
Isolation Voltage (Input to Output)	3750	V_{rms}
Operating Temperature	-40 to +85	°C
Storage Temperature	-40 to +125	°C

¹ Failure to comply will inhibit thermal shutdown.

² Derate Input Power linearly by 1.33mW/°C.

³ Derate Output Power linearly by 7.5mW/°C.

Absolute maximum electrical ratings are at 25°C, unless otherwise specified.

Absolute maximum ratings are stress ratings. Stresses in excess of these ratings can cause permanent damage to the device. Functional operation of the device at conditions beyond those indicated in the operational sections of this data sheet is not implied.

Typical values are characteristic of the device at +25°C, and are the result of engineering evaluations. They are provided for information purposes only, and are not part of the manufacturing testing requirements

1.4 ESD Rating

ESD Rating (Human Body Model)
1000 V

1.5 Recommended Operating Conditions

Parameter	Symbol	Min	Max	Units
Load Current, Continuous	I_L	-	300	$\text{mA}_{\text{rms}} / \text{mA}_{\text{DC}}$
		-	600	mA_{DC}
Input Control Current ¹	I_F	2.5	10	mA
Load Voltage ²	V_L	10	-	V
External Storage Capacitor	C_{EXT}	2	6	nF
Load Inductance ³	$L_{\text{LOAD,AC}}$	-	3.0	mH
	$L_{\text{LOAD,DC}}$	-	1.75	
Operating Temperature	T_A	-40	+85	°C

¹ Input control current must not exceed the maximum recommended value. Failure to comply may inhibit the thermal shutdown mechanism resulting in permanent damage to the device.

² Required only when using the optional external storage capacitor, C_{EXT} .

³ Maximum load inductance corresponds to a maximum load capacitance. If a TVS or other protection method is used, then no maximum load inductance applies.

1.6 Typical Configurations

1.6.1 AC/DC Application

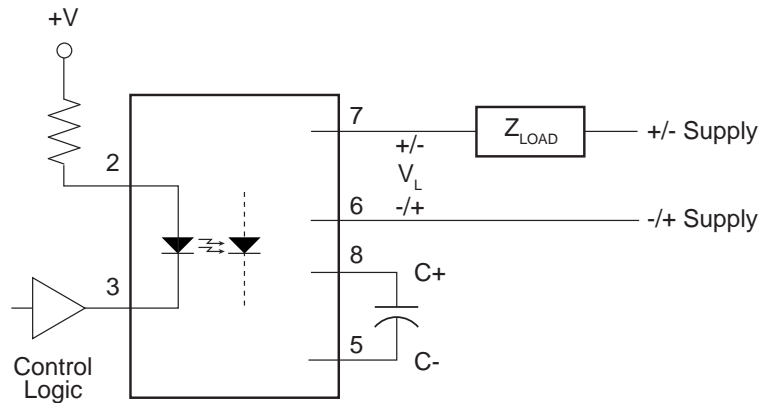

1.6.2 DC-Only Application

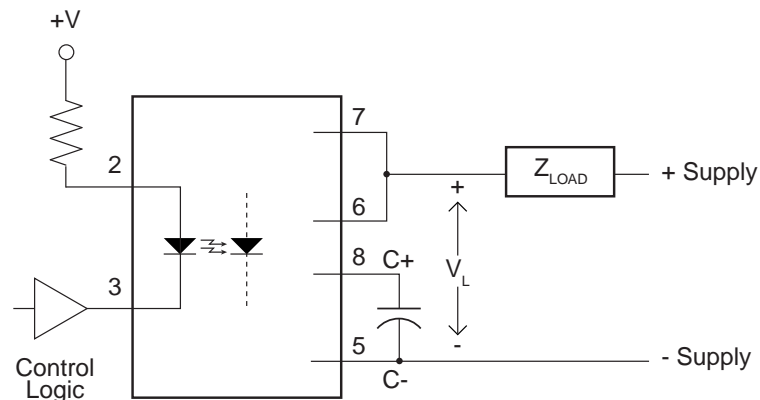

1.7 General Conditions

Unless otherwise specified, minimum and maximum values are guaranteed by production testing at 25°C only.

Typical values are characteristic of the device at 25°C and are the result of engineering evaluations. They are provided for informational purposes only and are not part of the manufacturing testing requirements.

Operating temperature range: $T_A = -40^{\circ}\text{C}$ to $+85^{\circ}\text{C}$

1.8 Electrical Specifications

Parameter	Conditions	Symbol	Min	Typ	Max	Units				
Output Characteristics @ 25°C										
Blocking Voltage	$I_L = 1\mu\text{A}$	V_{DRM}	60	-	-	V_P				
Current Limit	$I_F = 5\text{mA}$, $V_L = \pm 4\text{V}$, $t = 2\text{ms}$	I_{LMT}	470	614	900	mA_P				
AC/DC Configuration			1	1.2	1.5	A				
DC-Only Configuration	$I_F = 5\text{mA}$, $V_L = 4\text{V}$, $t = 2\text{ms}$									
On-Resistance ¹	$I_F = 5\text{mA}$, $I_L = 100\text{mA}$	R_{ON}	-	3.9	5.6	Ω				
AC/DC Configuration			-	1.09	1.4					
DC-Only Configuration										
Off-State Leakage Current	$V_L = 60\text{V}$	I_{LEAK}	-	-	1	μA				
Switching Speeds	$I_F = 5\text{mA}$, $I_L = 100\text{mA}$, $V_L = 10\text{V}$ $C_{\text{EXT}} = 1\text{nF}$					μs				
Turn-On							t_{on}	-	18	100
Turn-On, No Capacitor							t_{on}	-	112	250
Turn-Off	-	t_{off}	-	88	400					
Output Capacitance, AC/DC Configuration	$I_F = 0\text{mA}$, $V_L = 1\text{V}$	C_O	-	220	-	pF				
Thermal Shutdown	-	T_{SD}	-	130	-	$^{\circ}\text{C}$				
Input Characteristics @ 25°C										
Input Control Current to Activate	$I_L = 100\text{mA}$	I_F	-	-	1.1	mA				
Input Control Current to Deactivate	$I_L = 100\text{mA}$	I_F	0.1	0.43	-					
LED Forward Voltage	$I_F = 5\text{mA}$	V_F	0.9	1.22	1.5	V				
Common Characteristics @ 25°C										
Input to Output Capacitance	$V_{\text{IO}} = 0\text{V}$, $f = 1\text{MHz}$	C_{IO}	-	3	-	pF				
Thermal Characteristics										
Thermal Impedance, Junction-to-Ambient	-	$R_{\theta\text{JA}}$	-	114	-	$^{\circ}\text{C}/\text{W}$				

¹ Measurement taken within 1 second of on-time.

1.9 Switching Speed Test Circuits

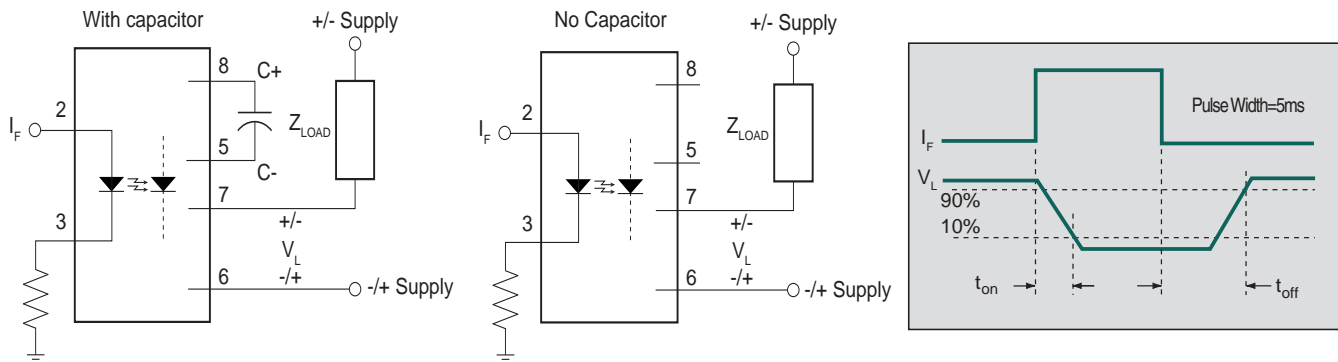

1.10 Performance Data

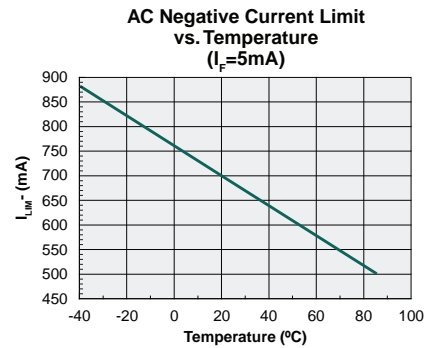
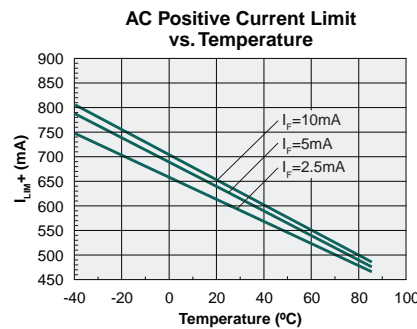
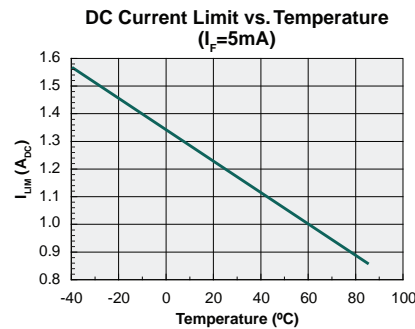
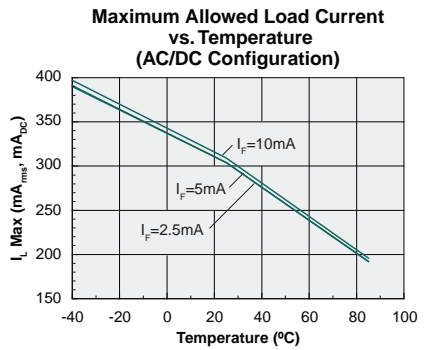
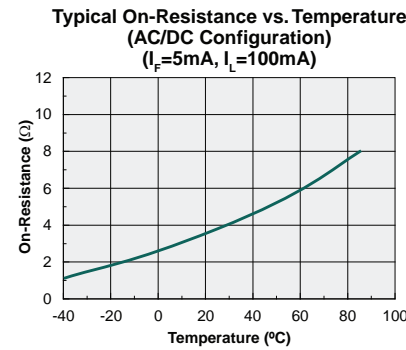
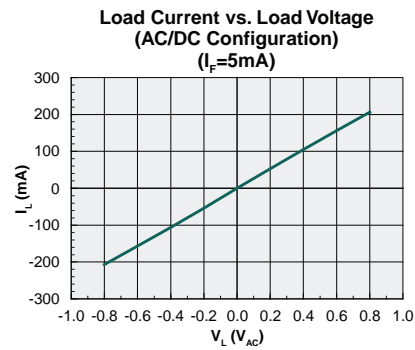
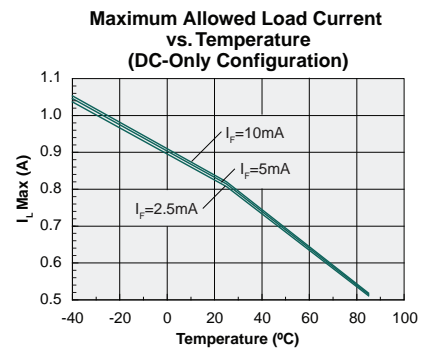
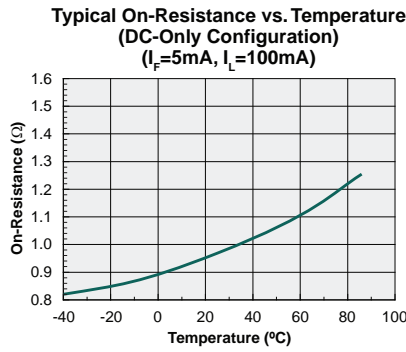
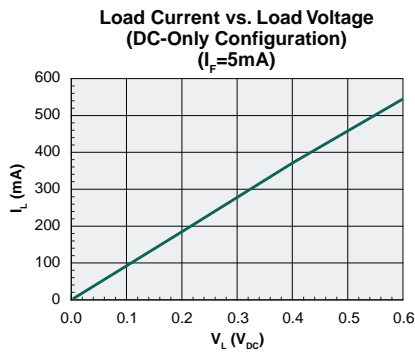
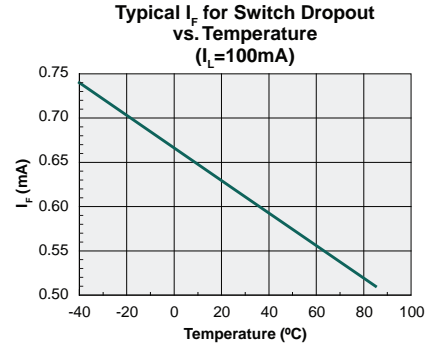
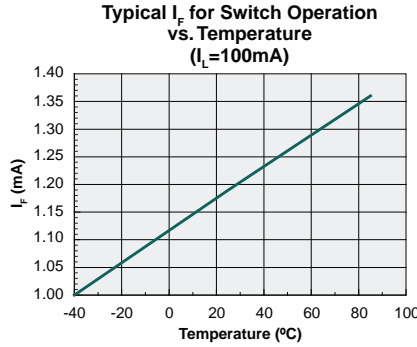
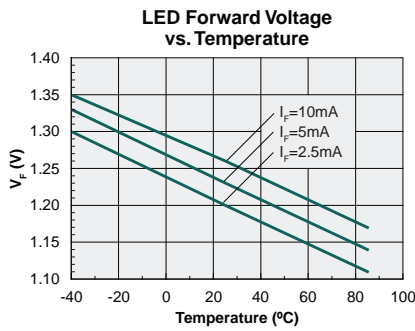

*Unless otherwise noted, data presented in these graphs is typical of device operation at 25°C.

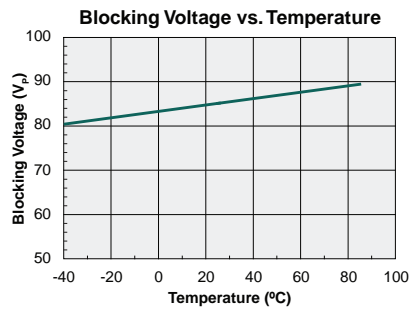
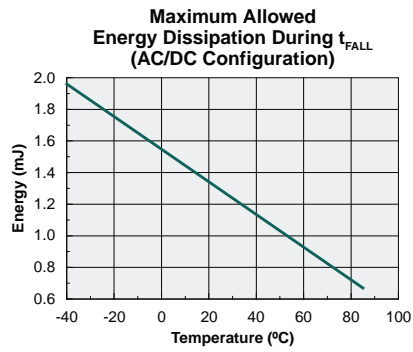
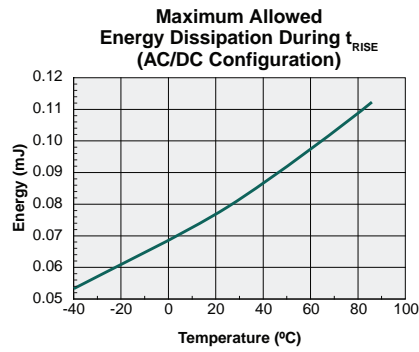
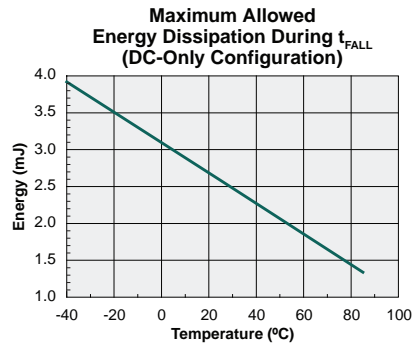
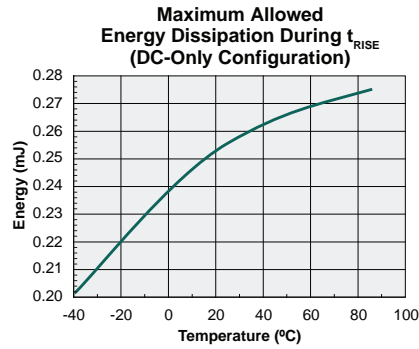

*Unless otherwise noted, data presented in these graphs is typical of device operation at 25°C.

2. Introduction

The CPC1560 is an optically coupled Solid State Relay (SSR) that is self-biased from the load supply. An optional external charge storage capacitor is used to speed up SSR turn-on. The CPC1560 also incorporates current limiting and a thermal shutdown feature in the output circuitry, making the device ideal for use in harsh conditions.

3. Functional Description

Internally, the device is composed of an LED, a photovoltaic array with control circuitry, and two MOSFET output switches.

Input current to the LED is the signal to turn-on the SSR's output MOSFET switches. The LED illuminates the photovoltaics, which provide current to the gates of the output MOSFETs, causing them to conduct. When utilizing C_{EXT} , the charge delivered to the MOSFET gates initially includes the charge stored in the external capacitor, causing the SSR to conduct more quickly than if only the photovoltaic current were used.

When the Load Voltage (V_L) is first applied to the inactive outputs, the external storage capacitor begins to charge. To ensure proper operation, the storage capacitor should be equal to or greater than the total gate capacitance of the two output MOSFET switches. Charge from the load voltage is passed through bootstrap diodes, which prevent the charge from escaping and discharging the capacitor through the MOSFET output switch when the SSR is turned on. The input control current is applied, then the charge is transferred from the storage capacitor through the internal NPN bipolar transistor along with the charge from the photovoltaic, to the MOSFET gates to accomplish a rapid turn-on. After the MOSFETs have turned on and the capacitor has discharged current from the photovoltaic continues to flow into the gates, keeping the MOSFETs turned on.

When the input control current is removed, gate current from the photovoltaic stops flowing and the PNP bipolar transistor turns on, discharging the MOSFET gates. The MOSFETs are now off. At this point, with load voltage applied, the capacitor begins recharging for the next turn on cycle.

The non-conducting, optical coupling space between the LED and the photovoltaics provides $3750V_{rms}$ of isolation between the control input and the switched output of the CPC1560.

Important things to note about the operation of the CPC1560:

- The device is designed to maintain its guaranteed operating characteristics with DC input control

current (I_F) in the range of 2.5mA to 10mA (see “**Recommended Operating Conditions**” on page 4). The device will operate at input currents above and below this range, but device operating characteristics over the operating temperature range are not guaranteed.

- There is a minimum LED input current required for the device to shut off: 0.1mA at 25°C (see “**Electrical Specifications**” on page 5).
- The output switch will only withstand a maximum of 60 volts across its terminals before breaking down (see “**Absolute Maximum Ratings**” on page 3). Maximum voltage generally occurs when the output is off.

The CPC1560 has two different operating configurations: unidirectional DC-only configuration, and bidirectional AC/DC configuration.

In the unidirectional DC-only configuration, the device switches load voltages with a fixed polarity, while in the AC/DC configuration it can switch voltages with either positive or negative polarities.

The advantage of operating the device in the DC-only configuration is the ability to switch larger load currents. The advantage of operating it in the AC/DC configuration is the flexibility of switching load voltages of either polarity.

4. Device Configuration

4.1 LED Resistor

To assure proper operation of the CPC1560, the LED resistor selection should comply with the recommended operating conditions. Although the LED is capable of being operated up to the absolute maximum ratings, this is not recommended. Operating the LED beyond the recommended operating conditions may prevent the current limit and thermal shutdown functions from performing properly. The equation to calculate the maximum resistor value is:

$$R_{LED_MAX} = \frac{V_{IN_MIN} - V_{LOW_MAX} - V_{F_MAX}}{I_{F_MIN}}$$

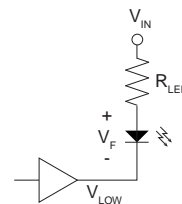

- I_{F_MIN} = Minimum Input Control Current
- V_{IN_MIN} = Minimum Input Power Source
- V_{LOW_MAX} = Maximum Logic Level Low Voltage
- V_{F_MAX} = Maximum Forward Voltage Drop of LED
- R_{LED_MAX} = Maximum Input Resistor to LED

4.2 Storage Capacitor

The CPC1560 utilizes an optional external capacitor (C_{EXT}) to meet the device's fastest turn-on specification. This external storage capacitor enables the relay to turn on more quickly by holding a reservoir of charge to be transferred to the gates of the MOSFET switches. The capacitor must have a minimum working voltage greater than the load voltage and be connected between pin 8 (C+), the capacitor's positive voltage terminal, and pin 5 (C-), the capacitor's negative voltage terminal.

Proper selection of the external storage capacitor begins with the recommended range provided in the **"Recommended Operating Conditions" on page 4**, and the maximum voltage at the CPC1560 outputs, including transients and faults. The nominal value of the capacitor needs to be chosen to ensure the capacitor's value remains within the recommended range over the operational conditions of the end product the effects of tolerance, temperature coefficient, and (for some types of capacitor) derating due to bias voltage are accounted for,

5. Operational Behavior

5.1 Operating Frequency

5.1.1 Duty Cycle/Power Dissipation

Equation 1 shows the relationship between power dissipation, operating frequency, and duty cycle for the CPC1560. From this equation, it can be seen that both switching frequency (f_{switch}) and duty cycle (D) contribute to power dissipation. The first one by generating switching losses, and the second one by generating ON losses. Switching losses are those caused by changes in the energy state of the load components when the device is switching on and off (i.e. E_{RISE} and E_{FALL}), and the ON losses are those caused by the flow of load current (I_L) through the output's on-resistance (R_{ON}) when it is switched on.

$$(1) P_{avg} = I_L^2 \cdot R_{ON} \cdot D + f_{switch} \cdot (E_{RISE} + E_{FALL})$$

Because a higher operating frequency translates into higher power consumed by the part, care must be taken to limit its value in order to protect the device from exceeding its maximum power rating. When doing this, both the maximum allowed power dissipation in the part and the ON duty cycle, $D = t_{ON} / (t_{ON} + t_{OFF})$, must be taken into consideration.

5.1.2 Temperature Effects

When setting the operating frequency of the CPC1560, the user must also take into account power dissipation over temperature.

5.1.3 Elements of Operating Frequency

In addition to ambient temperature, the maximum frequency of the CPC1560 is also determined by the MOSFET's turn-on and turn-off times and the load voltage rise and fall times as follows:

$$(2) f_{MAX} = \frac{1}{3} (t_{ON} + t_{OFF})^{-1}$$

Where 1/3 is a multiplication factor for temperature and process variations.

5.2 Switching Losses

During the transition intervals of the switching process, the load components change energy states, which results in switching losses as the energy passes through the MOSFETs. This energy transfer is manifested in the form of heat dissipation and must be taken into consideration.

Energy is transferred during the turn-off intervals. This energy, called E_{rise} , will be absorbed by the MOSFET output switches, and if present parasitic load capacitance and the protection device.

Energy is also transferred during the turn-on intervals and is called E_{fall} . This energy, will be absorbed by the MOSFET output switches, which is why it should be limited to the "Peak Turn-On Energy Dissipation" values specified in the Absolute Maximum Ratings Table of this datasheet.

The user of the CPC1560 device must understand the details of the load behavior and keep in mind the device's recommended operating conditions in order to adequately size the load components and protect the application circuit.

The average power of the CPC1560 output MOSFETs for any specific application and for any load type given by Equation 1 and repeated here is:

$$(3) P_{avg} = I_L^2 \cdot R_{ON} \cdot D + f_{switch} \cdot (E_{RISE} + E_{FALL})$$

From this equation we can see how the switching losses (E_{RISE} and E_{FALL}), together with the "on losses," contribute to the CPC1560's output power dissipation.

The user must also know that the recommended operating conditions for I_L , f_{SWITCH} , load capacitance

(C_{LOAD}) and load inductance (L_{LOAD}), along with other recommended operating conditions given in this datasheet, are constrained by the 85°C operation of most industrial applications. For lower operating temperature ranges, these values can be de-rated using the information provided in the temperature graphs in this datasheet.

5.2.1 Effects of Ambient Temperature

One of the most important factors is the temperature variation of the environment. From the **Maximum Allowed Energy Dissipation During t_{RISE}** graphs (AC/DC and DC-Only) in this datasheet, the user can see how the energy dissipated in the part during t_{RISE} increases with increasing ambient temperature.

The operating frequency of the device is directly related to the amount of energy dissipated in it during the transition times, t_{RISE} and t_{FALL} , which increases rapidly with temperature, as seen in the previously mentioned graphs. Depending on the operating temperature range of the application, the user must derate the maximum allowed energy in the part during t_{RISE} and t_{FALL} (according to the temperature graphs provided) in order to limit the operating switching frequency.

5.3 Current Limit and Thermal Shutdown

5.3.1 Current Limit

The CPC1560 has a current limit feature in which current through the output switches is limited to a value larger than the recommended operating current.

In the AC/DC configuration, the CPC1560 has bidirectional current limiting, which consists of current limit circuits for both positive and negative polarities. In the DC-only configuration, the DC current limit consists of the parallel of the two AC current limit circuits. The current limit function has a negative temperature coefficient in which increasing temperature lowers the current limit threshold of the device.

Prolonged periods of current limiting will cause the temperature of the device to increase, and, if allowed to continue, will activate the device's thermal shutdown circuitry, forcing the output switches to turn off.

5.3.2 Thermal Shutdown

The purpose of the thermal shutdown feature is to completely shut down the operation of the device when its junction temperature has gone above 130°C, whether this is due to high power dissipation in the

device in the form of heat or an increase in the ambient temperature.

The thermal shutdown feature and the current limit feature provide great power cross immunity to the device for improved survivability in harsh environments.

5.4 dV/dt Fault Tolerance

The CPC1560 device has a finite dV/dt fault tolerance for both the AC/DC and DC-only configurations, which must not be exceeded.

The dV/dt tolerance for the device in the AC/DC configuration is double that of the DC-only configuration (see "**Absolute Maximum Ratings**" on page 3). This is because the dV/dt value of the CPC1560 is inversely proportional to the size of the output switch's C_{RSS} , or "reverse transfer capacitance," and this capacitance in the DC-only configuration is double that in the AC/DC configuration.

5.5 Power Derating

Bear in mind the power rating of the CPC1560 when operating the device at elevated temperatures. The Absolute Maximum Ratings table shows the maximum allowed output power dissipation at 25°C is 787mW, which is the maximum power the output can dissipate before the junction temperature of the device reaches 125°C.

In order to keep the CPC1560 operating within its power rating, use the Maximum Allowed Load Current graphs provided earlier in this document.

5.6 Rise and Fall Times

The CPC1560 has rise and fall times that are primarily limited by internal parasitic elements of the device; the load components only play a secondary role. This can be appreciated in the turn-off graph of an application circuit operating at 45V, where the slope of the load voltage starts scooping down into a more capacitive shape after approximately 15 volts.

**DC-Only Application Circuit
Resistive Load Turn-Off Characteristics
(Supply=45V_{DC}, R_{LOAD}=75Ω)**

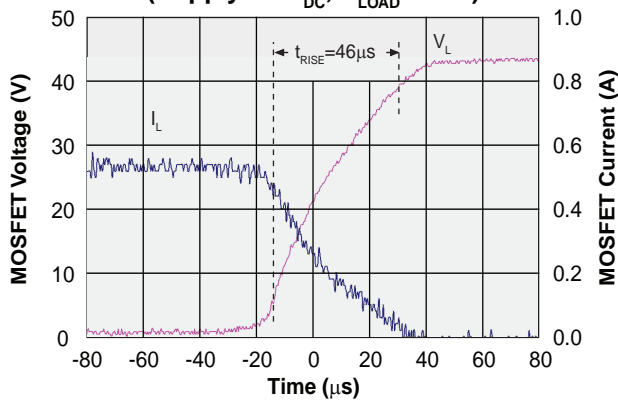

5.7 Over-Voltage Protection

5.7.1 Stored Energy in the Load

During the CPC1560's switching periods, energy is transferred between the load components, the CPC1560 device, and, if used, the over-voltage protection circuitry.

When the output switch turns off, inductive loads (L_{LOAD}) transfer their stored energy to the MOSFET switches, the load capacitance, and the over-voltage protector. (See the turn-off graph for a 45V inductive load application circuit.)

When the output switch turns on, the energy in the load inductor is zero, and the load capacitor (C_{LOAD}) must transfer its stored energy into the MOSFET.

**DC-Only Application Circuit
Inductive Load Turn-Off Characteristics
(Supply=45V, R_{LOAD}=75Ω, L_{LOAD}=630μH)**

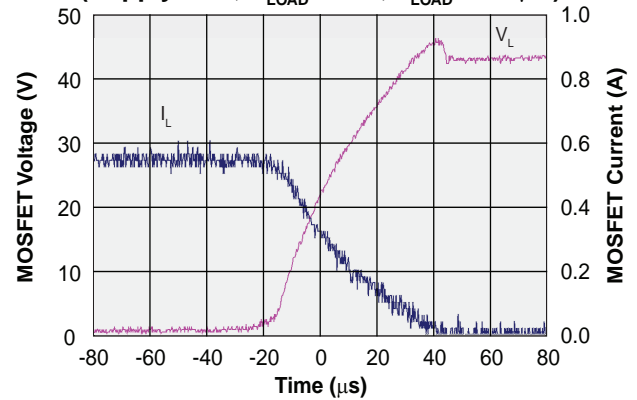

5.7.2 Protection Methods

One way to protect the CPC1560 and application circuit components from damage when excessive stored energy is suddenly released into the output MOSFETs of the CPC1560, is to add a Transient Voltage Suppressor (TVS) across the output switches. Use a unidirectional TVS from the outputs to C- for the DC-only configuration, and use a bidirectional TVS across the output pins for the AC/DC configuration as shown in the diagrams below.

In order to calculate the required TVS value, the user has to compare working voltage of the application circuit to the breakdown voltage of the CPC1560 with the TVS maximum clamping voltage ratings. The TVS maximum clamping capability must be, at a minimum, equal to the specific peak pulse current of the load. This must be done to ensure the TVS can easily

absorb any excess energy coming from the inductive load (L_{LOAD}).

In addition to the TVS, other protection techniques are also available depending on the type of load the user is trying to switch. For purely resistive loads the user may rely on the output transistor to handle any parasitic energy. For very low to moderately inductive loads (e.g. remote switching of a load through a long cable), a voltage suppressor or TVS can be used as explained before. For heavily inductive loads, a fly-back diode connected across the load element is recommended

For much higher inductive loads, other circuit techniques, device ratings and/or protector types must be considered¹. Of paramount importance is that the designer know the characteristics of the load being switched.

Figure 2. CPC1560 DC-Only Configuration with Over-Voltage Protection

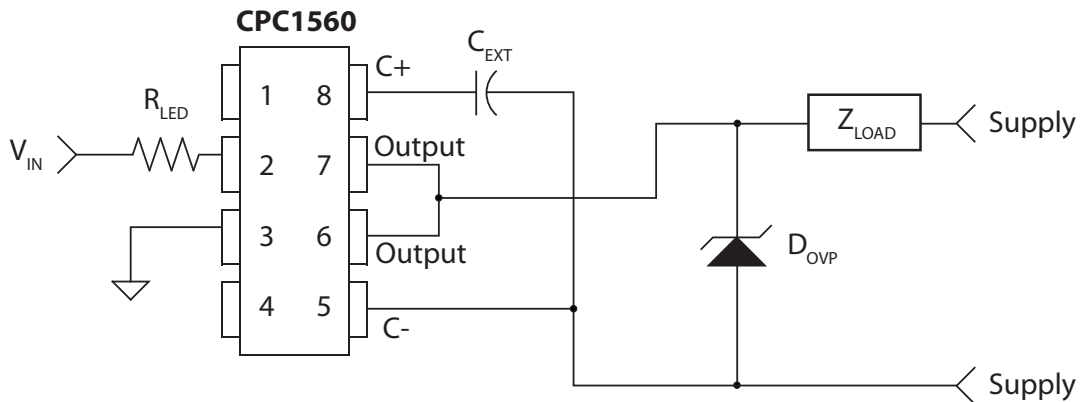
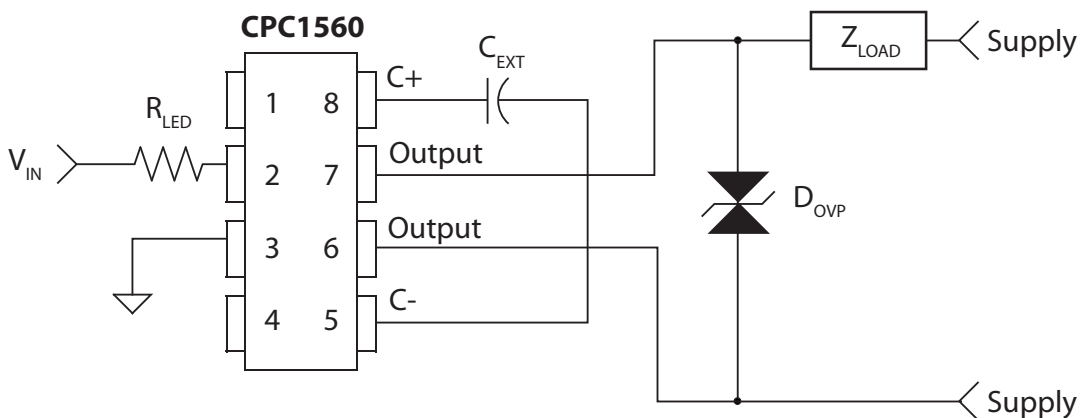

Figure 3. CPC1560 AC/DC Configuration with Over-Voltage Protection



¹ For more over voltage protection techniques consult: Switchmode Power Supply Handbook, 2nd Edition, Keith Billings, ISBN 0-07-006719-8, or Power MOSFET Design, B.E. Taylor, ISBN 0-471-93-802-5

6 Manufacturing Information

6.1 Moisture Sensitivity



All plastic encapsulated semiconductor packages are susceptible to moisture ingress. IXYS Integrated Circuits classifies its plastic encapsulated devices for moisture sensitivity according to the latest version of the joint industry standard, **IPC/JEDEC J-STD-020**, in force at the time of product evaluation. We test all of our products to the maximum conditions set forth in the standard, and guarantee proper operation of our devices when handled according to the limitations and information in that standard as well as to any limitations set forth in the information or standards referenced below.

Failure to adhere to the warnings or limitations as established by the listed specifications could result in reduced product performance, reduction of operable life, and/or reduction of overall reliability.

This product carries a **Moisture Sensitivity Level (MSL)** classification as shown below, and should be handled according to the requirements of the latest version of the joint industry standard **IPC/JEDEC J-STD-033**.

Device	Moisture Sensitivity Level (MSL) Classification
CPC1560G / CPC1560GS	MSL 1

6.2 ESD Sensitivity



This product is **ESD Sensitive**, and should be handled according to the industry standard **JESD-625**.

6.3 Soldering Profile

Provided in the table below is the **IPC/JEDEC J-STD-020** Classification Temperature (T_C) and the maximum dwell time the body temperature of these surface mount devices may be ($T_C - 5$)°C or greater. The Classification Temperature sets the Maximum Body Temperature allowed for these devices during reflow soldering processes.

Device	Classification Temperature (T_C)	Dwell Time (t_p)	Wave Cycles
CPC1560GS	250°C	30 seconds	3

For through-hole devices, the maximum pin temperature and maximum dwell time through all solder waves is provided in the table below. Dwell time is the interval beginning when the pins are initially immersed into the solder wave until they exit the solder wave. For multiple waves, the dwell time is from entering the first wave until exiting the last wave. During this time, pin temperatures must not exceed the maximum temperature given in the table below. Body temperature of the device must not exceed the limit shown in the table below at any time during the soldering process.

Device	Maximum Pin Temperature	Maximum Body Temperature	Maximum Dwell Time	Wave Cycles
CPC1560G	260°C	250°C	10 seconds*	1

*Total cumulative duration of all waves.

6.4 Board Wash

IXYS Integrated Circuits recommends the use of no-clean flux formulations. Board washing to reduce or remove flux residue following the solder reflow process is acceptable provided proper precautions are taken to prevent damage to the device. These precautions include but are not limited to: using a low pressure wash and providing a follow up bake cycle sufficient to remove any moisture trapped within the device due to the washing process. Due to the variability of the wash parameters used to clean the board, determination of the bake temperature and duration necessary to remove the moisture trapped within the package is the responsibility of the user (assembler). Cleaning or drying methods that employ ultrasonic energy may damage the device and should not be used. Additionally, the device must not be exposed to halide flux or solvents.



6.5 Mechanical Dimensions

6.5.1 CPC1560G DIP Package Dimensions

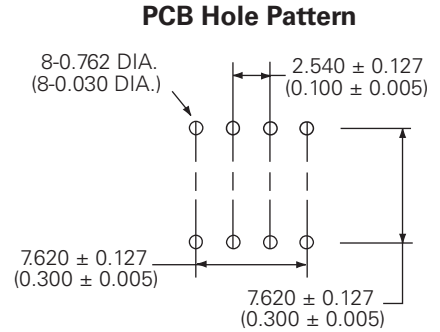
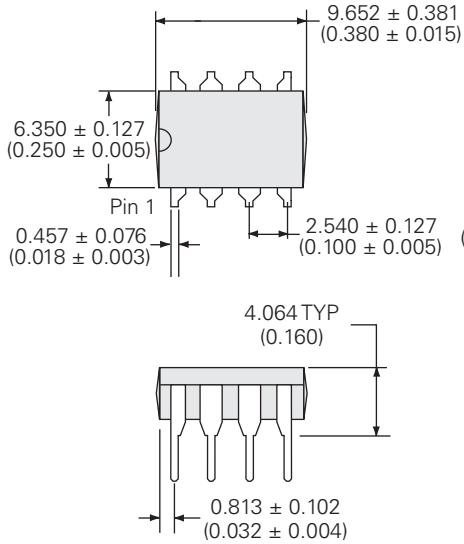

- Notes:
1. Controlling dimension: Inches
 2. Leadframe thickness does not include solder plating (1000µinches max)

Dimensions
mm
(inches)

6.5.2 CPC1560GS Surface Mount Package Dimensions

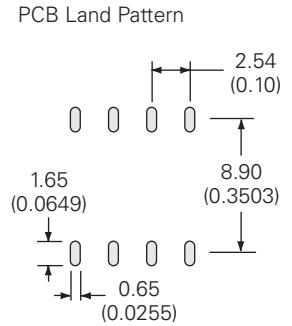
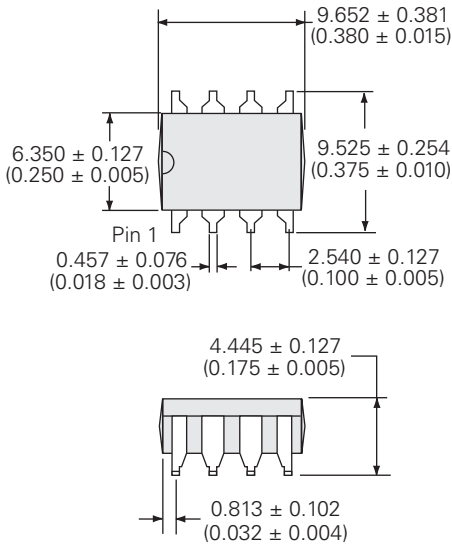

- Notes:
1. Controlling dimension: Inches
 2. Coplanarity = 0.004" (0.102 mm) max
 3. Leadframe thickness does not include solder plating (1000µinches max)

Dimensions
mm
(inches)

6.5.3 CPC1560GSTR Tape and Reel Specification

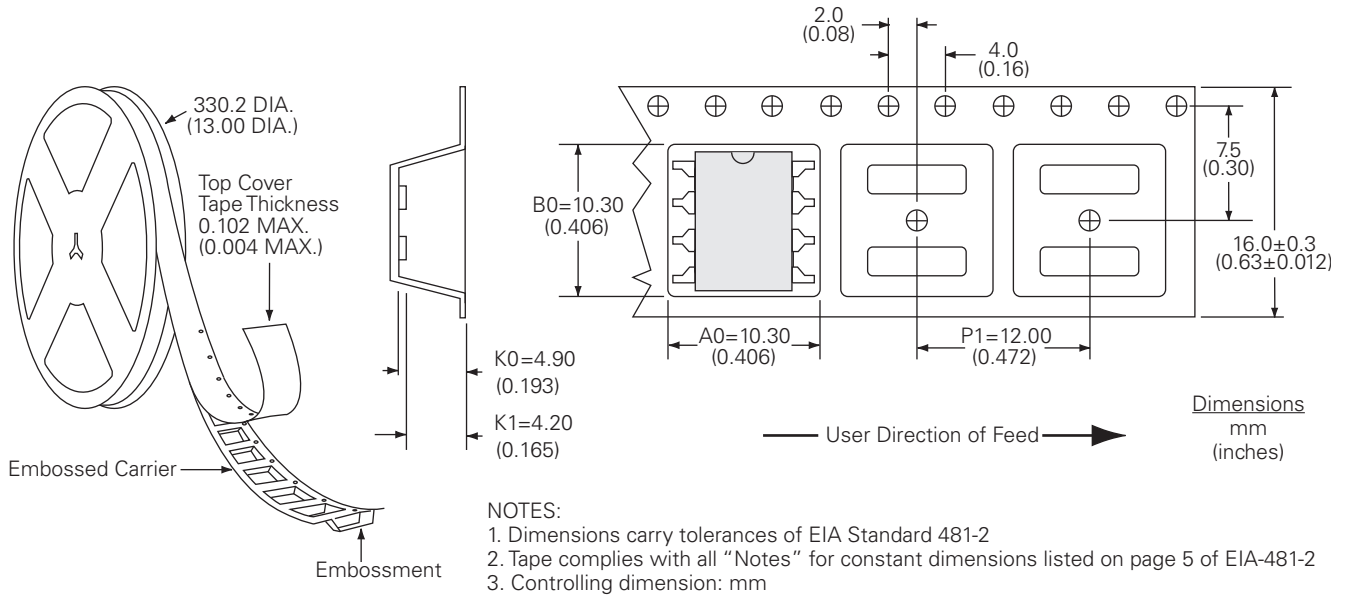

For additional information please visit our website at: <https://www.ixysic.com>



Disclaimer Notice - Information furnished is believed to be accurate and reliable. However, users should independently evaluate the suitability of and test each product selected for their own applications. Littelfuse products are not designed for, and may not be used in, all applications. Read complete Disclaimer Notice at <https://www.littelfuse.com/disclaimer-electronics>.

Specification: DS-CPC1560-R04
©Copyright 2025, Littelfuse, Inc.
OptoMOS® is a registered trademark of Littelfuse, Inc.
All rights reserved. Printed in USA.
11/18/2025