

PLB150

250V, 250mA Single -Pole, Normally Closed Relay

Key Attributes

Characteristic	Rating	Unit
Blocking Voltage	250	V _P
Load Current	250	mA _{RMS} /mA _{DC}
On-resistance (max.)	7	Ω
LED Current to Operate	5	mA

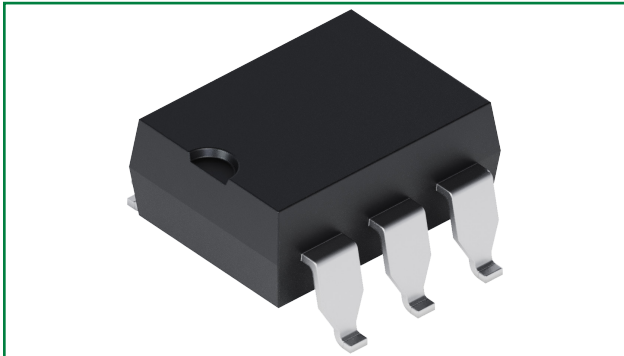

Pin Configuration

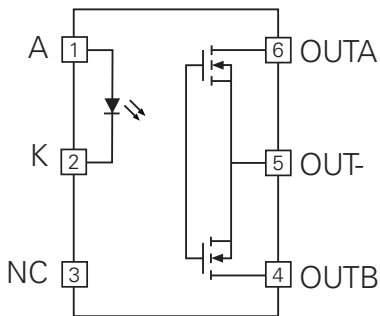

Switching Characteristics of Normally Closed Device

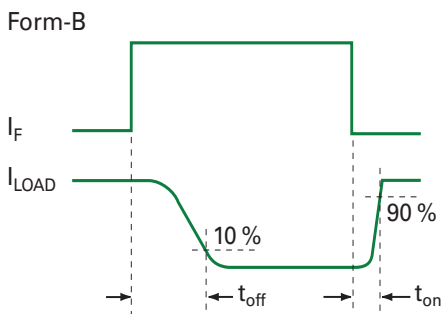

Description



PLB150 is a 250 V, 250 mA, 7 Ω, single-pole, normally closed (1-Form-B) solid state relay that uses optically coupled technology to provide an enhanced 3750V_{RMS} isolation barrier between the input and the output of the relay. The efficient MOSFET switches use Littelfuse Integrated Circuits' patented OptoMOS architecture while the optically coupled output is controlled by a highly efficient infrared LED.

Features

- 3750 V_{RMS} Input/Output Isolation
- Low Drive Power Requirements
- Greater Reliability than Electromechanical Relays
- VDE Compatible
- FCC Compatible
- Small 6-Pin Package
- No EMI/RFI Generation

Applications

- Telecommunications
 - Telecomm Switching
 - Tip/Ring Circuits
 - Modem Switching (Laptop, Notebooks, Pocket Size)
 - Hook Switch
 - Dial Pulsing
 - Ground Start
 - Ringing Injection
- Instrumentation
- Multiplexers
- Data Acquisition
- Electronic Switching
- I/O Subsystems
- Meters (Watt-Hour, Water, Gas)
- Medical Equipment—Patient/Equipment Isolation
- Security
- Industrial Controls

Approvals

- UL 1577 Recognized Component: File E76270
- TUV EN 62368-1: Certificate # B 082667 0008

Ordering Information

Part Number	Description
PLB150	6-Pin DIP (50/Tube)
PLB150S	6-Pin Surface Mount (50/Tube)
PLB150STR	6-Pin Surface Mount (1,000/Reel)

Specifications

Absolute Maximum Ratings

Parameter	Ratings	Units
Blocking Voltage	250	V _P
Reverse Input Voltage	5	V
Input Control Current	50	mA
Peak (10 ms)	1	A
Input Power Dissipation ¹	150	mW
Total Power Dissipation ²	800	
Isolation Voltage, Input to Output	3750	V _{RMS}
Operational Temperature, Ambient	-40 to +85	°C
Storage Temperature	-40 to +125	

¹ Derate linearly 1.33 mW/°C

² Derate output power linearly 6.67 mW/°C

Absolute Maximum Ratings are stress ratings. Stresses in excess of these ratings can cause permanent damage to the device. Functional operation of the device at conditions beyond those indicated in the operational sections of this data sheet is not implied.

Typical values are characteristic of the device at +25 °C, and are the result of engineering evaluations. They are provided for information purposes only, and are not part of the manufacturing testing requirements.

Electrical Characteristics @ 25°C

Parameter	Conditions	Symbol	Value			Units
			Minimum	Typical	Maximum	
Output Characteristics						
Blocking voltage	I _L = 1 μA	V _{DRM}	250	—	—	V _P
Load current:						
Continuous, AC/DC Configuration	—	I _L	—	—	250	mA _{RMS} /mA _{DC}
Continuous, DC Configuration			—	—	350	mA _{DC}
Peak	t = 10 ms	I _{LPK}	—	—	±500	mA _P
On-resistance ¹						
AC/DC Configuration	I _L = 250 mA	R _{ON}	—	—	7	Ω
DC Configuration	I _L = 350 mA		—	—	3	
Off-state leakage current	V _L = 250 V _P	I _{LEAK}	—	—	1	μA
Switching speeds:						
Turn-on	I _F = 5 mA, V _L = 10 V	t _{on}	—	—	1	ms
Turn-off		t _{off}	—	—	2.5	
Output capacitance	I _F = 0 mA, V _L = 50 V, f = 1 MHz	C _{OUT}	—	110	—	pF
Input Characteristics						
Input control current to activate	I _L = 250 mA	I _F	—	—	5	mA
Input voltage drop to deactivate	—	V _F	0.8	—	—	V
Input voltage drop	I _F = 5 mA	V _F	0.9	1.36	1.5	
Reverse input current	V _R = 5 V	I _R	—	—	10	μA
Common Characteristics						
Capacitance, input to output	V _{IO} = 0 V, f = 1 MHz	C _{IO}	—	3	—	pF

¹ Measurement taken within 1 second of on-time.

Load Configuration Methods

The diagrams below show load connection methods based on selected application circuit option.

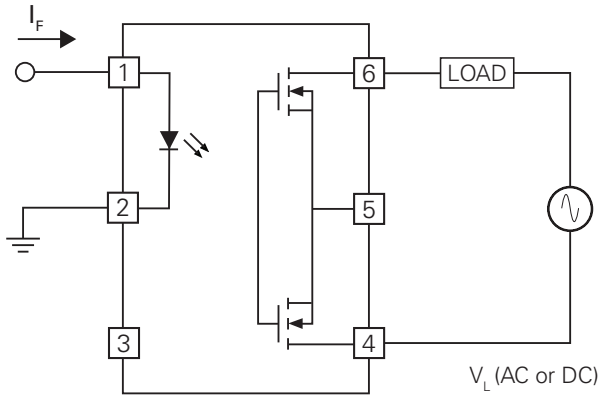

Figure 1. AC/DC, Bidirectional Load Configuration

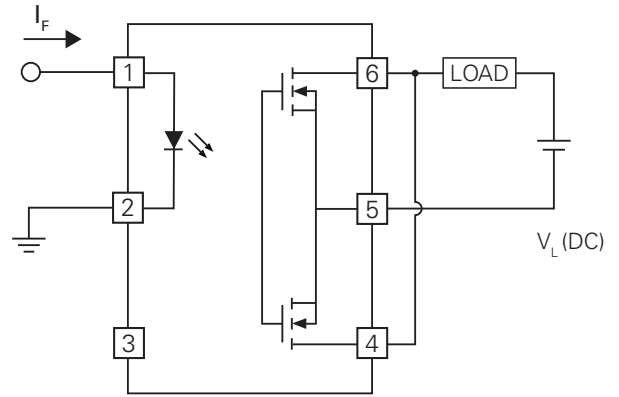

Figure 2. DC, Unidirectional Load Configuration

Manufacturing Information

Moisture Sensitivity



All plastic encapsulated semiconductor packages are susceptible to moisture ingress. Littelfuse classifies its plastic encapsulated devices for moisture sensitivity according to the latest version of the joint industry standard, **IPC/JEDEC J-STD-020**, in force at the time of product evaluation. We test all of our products to the maximum conditions set forth in the standard, and guarantee proper operation of our devices when handled according to the limitations and information in that standard as well as to any limitations set forth in the information or standards referenced below.

Failure to adhere to the warnings or limitations as established by the listed specifications could result in reduced product performance, reduction of operable life, and/or reduction of overall reliability.

This product carries a **Moisture Sensitivity Level (MSL)** classification as shown below, and should be handled according to the requirements of the latest version of the joint industry standard **IPC/JEDEC J-STD-033**.

Device	Moisture Sensitivity Level (MSL) Classification
PLB150S	MSL 1

ESD Sensitivity



This product is ESD Sensitive, and should be handled according to the industry standard **JESD-625**.

Soldering Profile

Provided in the table below is the **IPC/JEDEC J-STD-020** Classification Temperature (T_C) and the maximum dwell time ($T_C - 5^\circ\text{C}$). The Classification Temperature sets the Maximum Body Temperature allowed for these devices during reflow soldering processes.

Device	Classification Temperature (T_C)	Dwell Time (T_P)	Max Reflow Cycles
PLB150S	250°C	30 seconds	3

For through-hole devices, the maximum pin temperature and maximum dwell time through all solder waves is provided in the table below. Dwell time is the interval beginning when the pins are initially immersed into the solder wave until they exit the solder wave. For multiple waves, the dwell time is from entering the first wave until exiting the last wave. During this time, pin temperatures must not exceed the maximum temperature given in the table below. Body temperature of the device must not exceed the limit shown in the table below at any time during the soldering process.

Device	Maximum Pin Temperature	Maximum Body Temperature	Maximum Dwell Time	Wave Cycles
PLB150	260°C	250°C	10 seconds*	1

*Total cumulative duration of all waves.

Board Wash

Littelfuse recommends the use of no-clean flux formulations. Board washing to reduce, or remove flux residue following the solder reflow process is acceptable, provided proper precautions are taken to prevent damage to the device. These precautions include, but are not limited to: Using a low pressure wash and providing a follow-up bake cycle sufficient to remove any moisture trapped within the device, due to the washing process. Due to the variability of the wash parameters used to clean the board, determination of the bake temperature and duration necessary to remove the moisture trapped within the package is the responsibility of the user (assembler). Cleaning, or drying methods that employ ultrasonic energy may damage the device and should not be used. Additionally, the device must not be exposed to halide flux or solvents.



Mechanical Dimensions

PLB150

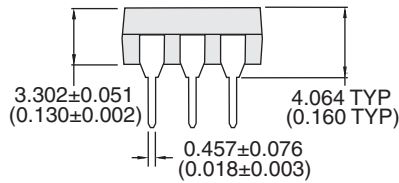
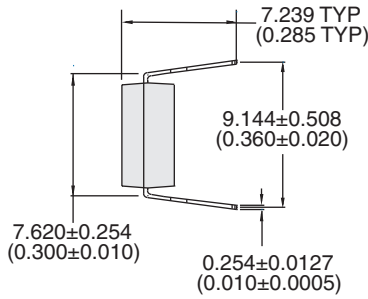
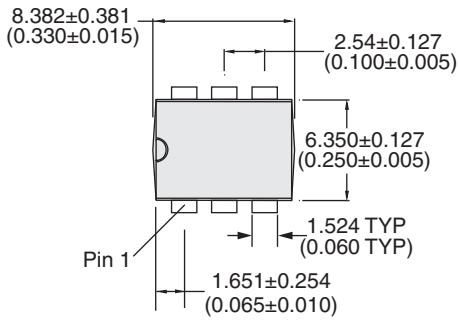

PCB Hole Pattern

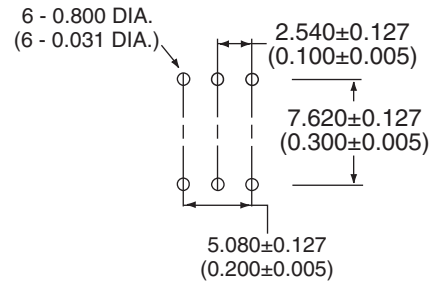

Controlling dimension: inches

Dimensions
mm
(inches)

PLB150S

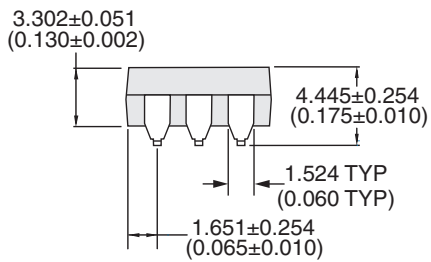
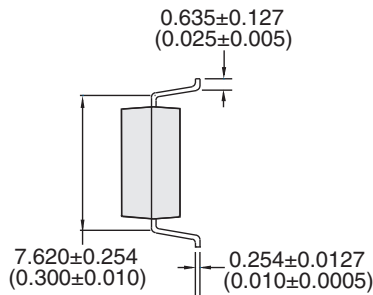
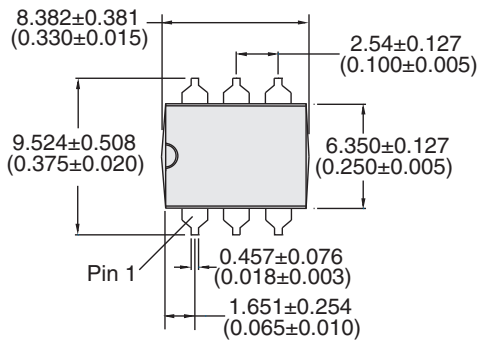

PCB Land Pattern

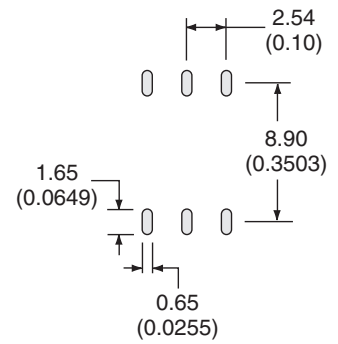

Controlling dimension: inches

Dimensions
mm
(inches)

PLB150STR Tape and Reel Packaging

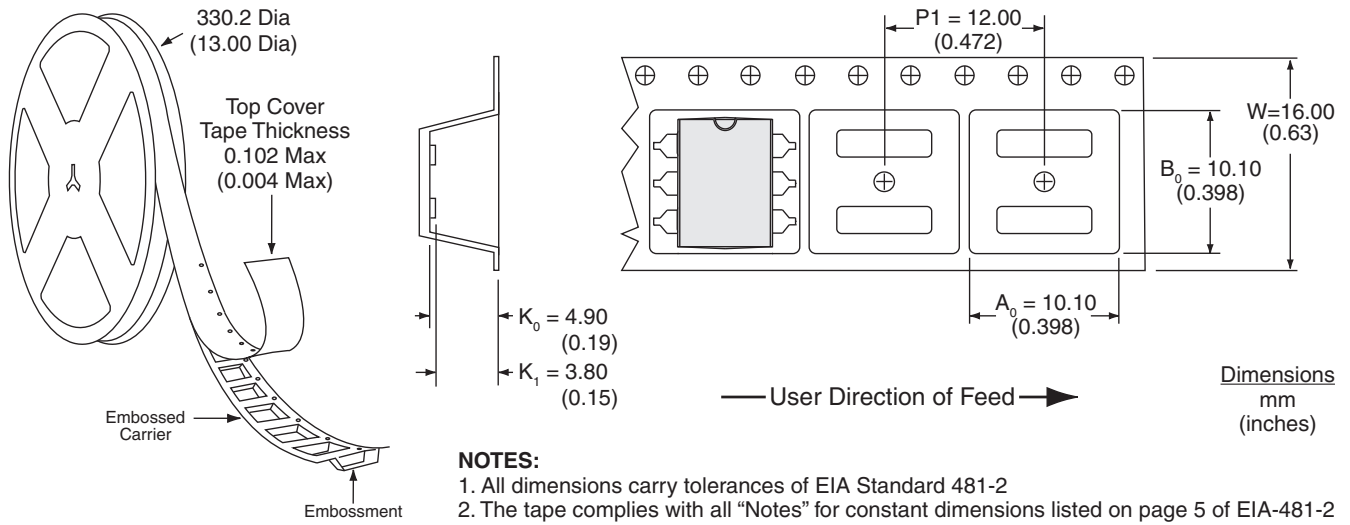

Disclaimer Notice - Information furnished is believed to be accurate and reliable. However, users should independently evaluate the suitability of and test each product selected for their own applications. Littelfuse products are not designed for, and may not be used in, all applications. Read complete Disclaimer Notice at <https://www.littelfuse.com/disclaimer-electronics>