

# LF21235TMR

## TMR Omni-polar Switch 17 Gauss 1.5uA PushPull Z Axis Sensor

RoHS



### Description

The LF21235TMR TMR Switch is a digital omni-polar magnetic switch that integrates TMR and CMOS technology in order to provide a magnetically triggered digital switch with high sensitivity, high speed, and low power consumption.

It contains a TMR magnetic sensor and CMOS signal processing circuitry within the same package, including an on-chip TMR voltage generator for precise magnetic sensing, a TMR voltage amplifier and comparator plus a Schmitt trigger to provide switching hysteresis for noise rejection, CMOS push-pull output and Z axis sensing direction.

An internal band gap regulator is used to provide a temperature compensated supply voltage for internal circuits, permitting a wide range of supply voltages.

It draws only 1.5µA (see Features below) resulting in low power operation, additionally it has fast response, accurate switching points, excellent thermal stability, and immunity to stray field interference. It is available in the SOT23-3 package. The output of the LF21235TMR switches low (turns on) when the magnetic field parallel to the sensing axis exceeds the operate point threshold, BOP. When the magnetic field is reduced below the release point BRP device output switches high (turns off). The difference between the BOP and the BRP is the hysteresis BH of the device.

### Functional Block Diagram

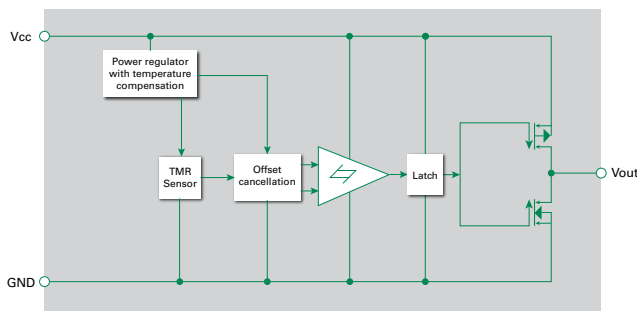

### TMR Switch Typical Applications Circuit

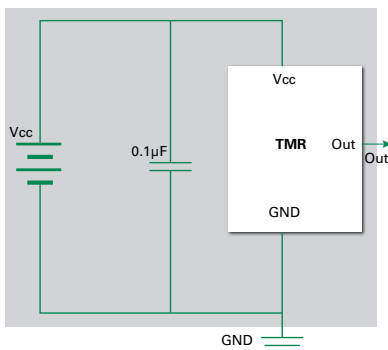

**Note:** It is strongly recommended that an external bypass capacitor be connected in-close-proximity to the device between the supply and ground pins to reduce noise. The recommended value for the external bypass capacitor is 0.1µF.

### Features and Benefits

- Tunneling Magnetoresistance (TMR) technology
- Low power consumption at 1.5µA
- Z axis sensing direction
- High frequency up to 1kHz
- Operation with north or south pole
- 1.8V to 5.5V operating range
- Low switching points for high sensitivity
- Excellent thermal stability
- High tolerance to external magnetic field interference
- Wider airgap capability
- Operates with smaller magnets for cost reduction
- RoHS compliant

### Applications

- Proximity detection
- Utility meters including gas, water, electric and heat meters
- High speed sensing
- Low power applications
- Rotary sensing
- Drop-in Hall switch replacement

### Output Behavior Versus Magnetic Pole

Parameter	Test Conditions	Output (volts)
South Pole	$B > B_{OPS}$	Low (On)
	$0 < B < B_{RPS}$	High (Off)
North Pole	$B < B_{OPN}$	Low (On)
	$0 > B > B_{RPN}$	High (Off)

**Note:** When power is turned on under Zero magnetic field, the output is "High".

**LF21235TMR****TMR Omni-polar Switch 17 Gauss 1.5uA PushPull Z Axis Sensor****Absolute Maximum Ratings (@TA = +25°C, unless otherwise specified)**

Symbol	Characteristics	Values	Unit
V <sub>CC</sub>	Supply Voltage	7.0	V
V <sub>RCC</sub>	Reverse Supply Voltage	0.3	V
I <sub>OUTSINK</sub>	Output Current	9.0	mA
B	Magnetic Flux Density	2800	Gauss
V <sub>ESD</sub>	ESD level(HBM)	4	kV
T <sub>A</sub>	Operating Temperature	-40 ~ 125	°C
T <sub>stg</sub>	Storage Temperature	-50 ~ 150	°C

**Note:** Stresses greater than the 'Absolute Maximum Ratings' specified above may cause permanent damage to the device. These are stress ratings only; functional operation of the device at these or any other conditions exceeding those indicated in this specification is not implied. Device reliability may be affected by exposure to absolute maximum rating conditions for extended periods of time.

**Electrical Characteristics (@TA = +25°C, Vcc = 3.0V)**

Symbol	Characteristics	Min.	Typ.	Max.	Unit	Conditions
V <sub>CC</sub>	Supply Voltage	1.8	3.0	5.5	V	Operating
V <sub>OH</sub>	Output High Voltage	V <sub>CC</sub> -0.3	-	V <sub>CC</sub>	V	-
V <sub>OL</sub>	Output Low Voltage	0	-	0.2	V	-
I <sub>CC</sub>	Supply Current	-	1.5	2.5	μA	Output Open
Freq	Response Frequency	-	1.0	-	kHz	-

**Magnetic Characteristics (@TA = +25°C, Vcc = 3.0V)**

Symbol	Characteristics	Min.	Typ.	Max.	Unit
B <sub>OPS</sub>	Operation Point	8	17	34	Gauss
B <sub>OPN</sub>		-34	-17	-8	Gauss
B <sub>RPS</sub>	Release Point	5	10	30	Gauss
B <sub>RPN</sub>		-30	-10	-5	Gauss
B <sub>H</sub>	Hysteresis	-	7	-	Gauss

# LF21235TMR

TMR Omni-polar Switch 17 Gauss 1.5uA PushPull Z Axis Sensor

## Pin Configuration and Sensing Direction of Magnetic Field

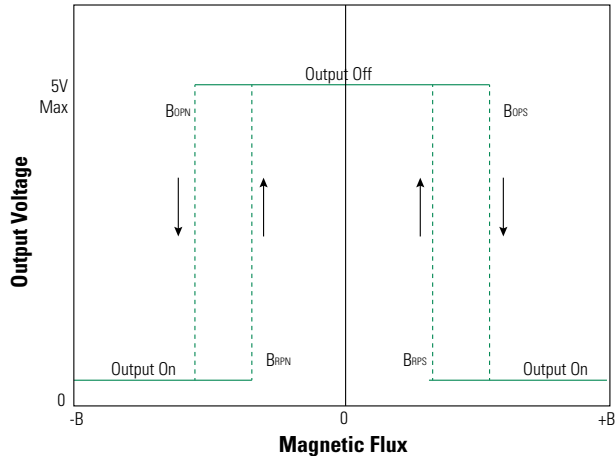
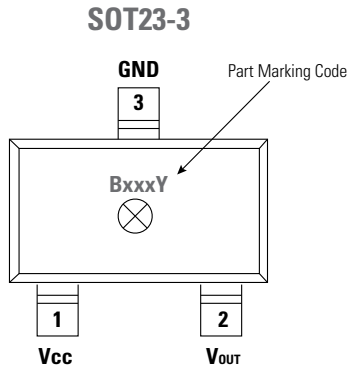

Part Marking Code:  
 BxxxY: B = LF21235TMR; xxx = Julian manufactured date; y = manufactured year  
 Moisture Sensitivity Level: Rating is 3  
 Pick and Place Nozzle: Samsung CN140 or equivalent

Pin Name	Pin No. SOT23-3	Pin Function
Vout	2	Output
GND	3	Ground
Vcc	1	Supply Voltage

### Part Numbering System

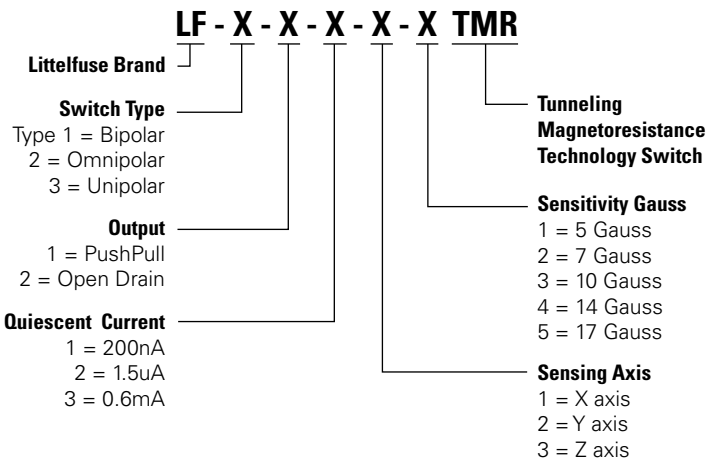

**Example:** LF11115 is Bipolar, Push Pull, 200 nA, X axis, 17 Gauss  
**Note:** Every combination is NOT offered. Contact Littelfuse for availability.

# LF21235TMR

TMR Omni-polar Switch 17 Gauss 1.5uA PushPull Z Axis Sensor

## Soldering Profile for Lead-free packages

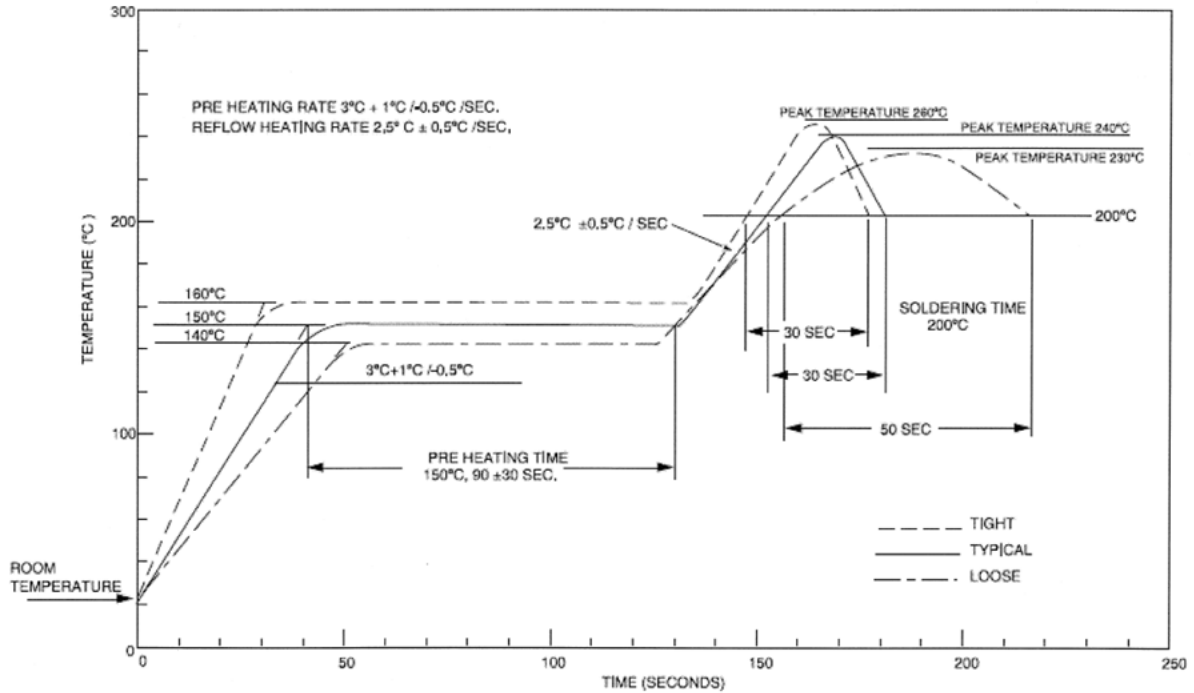

## Tape and Reel

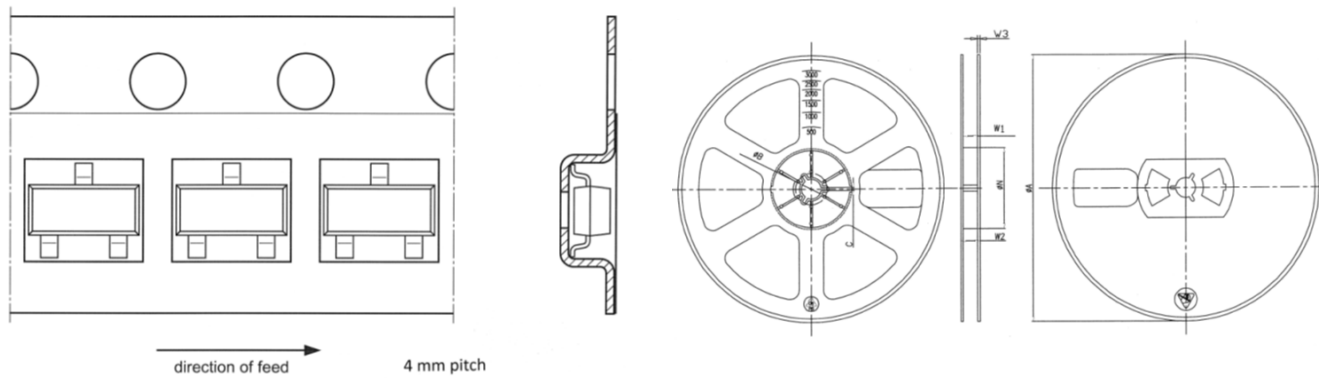

ØA	ØN	ØB	C	W1	W2	W3
178±2	54±2	13.2±0.3	2.2±0.3	8.4±1.5/0.0	12 MAX	1.4±0.4

# LF21235TMR

TMR Omni-polar Switch 17 Gauss 1.5uA PushPull Z Axis Sensor

### SOT23-3 Package Information

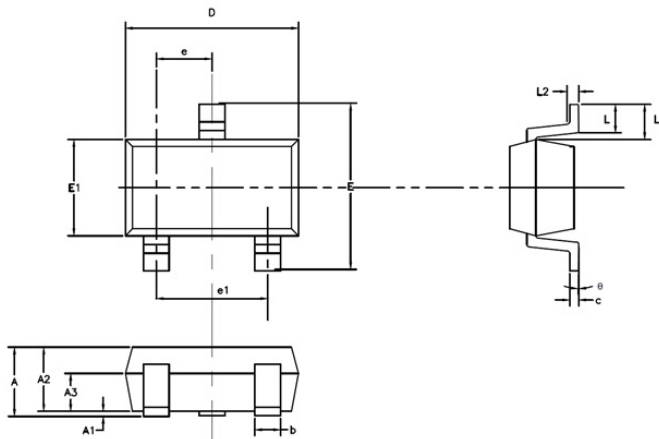

Symbol	Dimensions in Millimeters			Dimensions in Inches		
	Min	Nom	Max	Min	Nom	Max
A	-	-	1.45	-	-	0.057
A1	0.00	-	0.15	0.000	-	0.006
A2	0.90	1.10	1.30	0.035	0.043	0.051
A3	0.60	0.65	0.70	0.024	0.026	0.028
b	0.39	-	0.49	0.015	-	0.019
c	0.12	-	0.19	0.005	-	0.007
D	2.85	2.95	3.05	0.112	0.116	0.120
E	2.60	2.80	3.00	0.102	0.110	0.118
E1	1.55	1.65	1.75	0.061	0.065	0.069
e	0.85	0.95	1.05	0.033	0.037	0.041
e1	1.80	1.90	2.00	0.071	0.075	0.079
L	0.35	0.45	0.60	0.014	0.018	0.024
L1		0.59REF			0.023REF	
L2		0.25BSC			0.01BSC	
Ø	0°	-	8°	0°	-	8°

### TMR Sensor Position (SOT23-3 Elements)

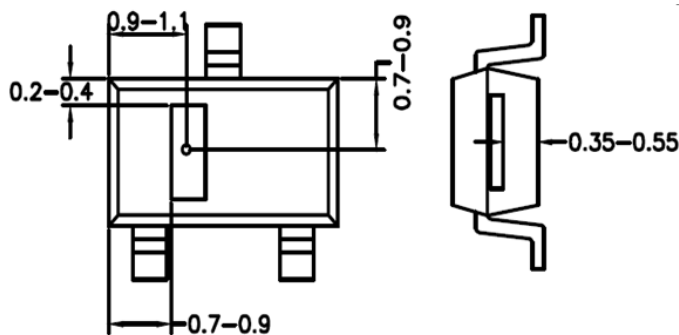

**Important Notice** - Littelfuse products are not designed for, and shall not be used for, any purpose (including, without limitation, automotive, military, aerospace, medical, life-saving, life-sustaining or nuclear facility applications, devices intended for surgical implant into the body, or any other application in which the failure or lack of desired operation of the product may result in personal injury, death, or property damage) other than those expressly set forth in applicable Littelfuse product documentation. Warranties granted by Littelfuse shall be deemed void for products used for any purpose not expressly set forth in applicable Littelfuse documentation. Littelfuse shall not be liable for any claims or damages arising out of products used in applications not expressly intended by Littelfuse as set forth in applicable Littelfuse documentation. The sale and use of Littelfuse products is subject to Littelfuse Terms and Conditions of Sale, unless otherwise agreed by Littelfuse.

**Disclaimer Notice** - Information furnished is believed to be accurate and reliable. However, users should independently evaluate the suitability of and test each product selected for their own applications. Littelfuse products are not designed for, and may not be used in, all applications. Read complete Disclaimer Notice at: [www.littelfuse.com/disclaimer-electronics](http://www.littelfuse.com/disclaimer-electronics).