

SC3051-04HTG

6 V, 22 A, SOT23-6, Lightning Surge Protection

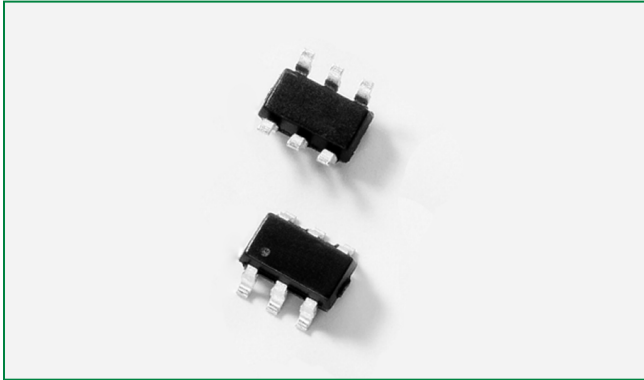

Pinout

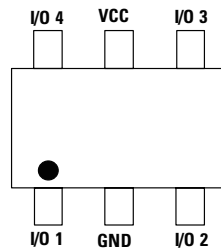

Functional Block Diagram

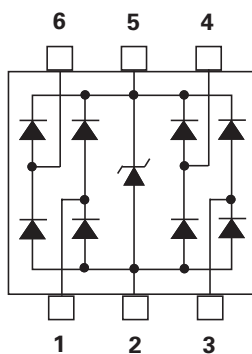

Applications

- 10/100/1000 Ethernet
- Firewire
- Flat panel displays
- LCD/PDP TVs
- Monitors
- Notebooks
- Portable medical
- Set top boxes

Life Support Note:

Not Intended for Use in Life Support or Life Saving Applications

The products shown herein are not designed for use in life sustaining or life saving applications unless otherwise expressly indicated.

Description

The SC3051-04HTG TVS diode array integrates low-capacitance rail-to-rail diodes with an additional Zener diode to protect each I/O pin against ESD and high surge events. This robust component can safely absorb 22 A of current per IEC 61000-4-5 ($t_p = 8/20 \mu s$) without performance degradation and has a minimum ± 30 kV ESD rating per IEC 61000-4-2 2nd edition. Their very low off-state capacitance is compatible with high-speed circuits.

Features

- ESD, IEC 61000-4-2, ± 30 kV contact/air
- EFT, IEC 61000-4-4, 40 A (5/50 ns)
- Maximum surge tolerance, IEC 61000-4-5 2nd edition, 22 A (8/20 μs)
- Low capacitance of 2.0 pF (typ) per I/O
- Low leakage current of 0.5 μA (max) at 6 V
- Small SOT23-6 packaging
- Halogen-free, lead-free, and RoHS-compliant

Application Examples

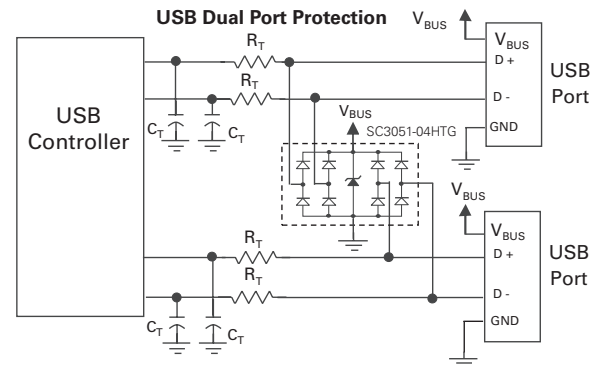

10/100/1000 Ethernet Protection

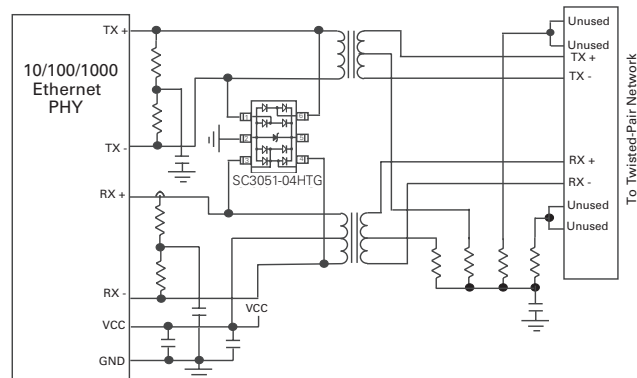

SC3051-04HTG

6 V, 22 A, SOT23-6, Lightning Surge Protection

Absolute Maximum Ratings

Symbol	Parameter	Value	Units
I_{PP}	Peak Current ($t_p = 8/20 \mu s$)	22	A
T_{OP}	Operating Temperature	-40 to 125	°C
T_{STOR}	Storage Temperature	-55 to 150	°C

Caution: Stresses above those listed in "Absolute Maximum Ratings" may cause permanent damage to the component. This is a stress only rating and operation of the component at these or any other conditions above those indicated in the operational sections of this specification is not implied.

Electrical Characteristics ($T_{OP} = 25 \text{ }^\circ\text{C}$)

Parameter	Symbol	Test Conditions	Min	Typ	Max	Units
Reverse Standoff Voltage	V_{RWM}				6	V
Breakdown Voltage	V_{BR}	$I_R = 1 \text{ mA}$, I/O to GND	7	8.5	10	V
Reverse Leakage Current	I_{LEAK}	$V_R = 6 \text{ V}$, I/O to GND		0.1	0.5	μA
Clamp Voltage ¹	V_C	$I_{PP} = 1 \text{ A}$, $t_p = 8/20 \mu s$, I/O to GND		9.0	10.5	V
		$I_{PP} = 10 \text{ A}$, $t_p = 8/20 \mu s$, I/O to GND		11.5	15.0	
		$I_{PP} = 22 \text{ A}$, $t_p = 8/20 \mu s$, I/O to GND		14.3	17	
Dynamic Resistance ²	R_{DYN}	TLP, $t_p = 100 \text{ ns}$, I/O to GND		0.15		Ω
ESD Withstand Voltage ^{1,3}	V_{ESD}	IEC 61000-4-2 (Contact Discharge)	± 30			kV
		IEC 61000-4-2 (Air Discharge)	± 30			kV
Diode Capacitance ¹	C_{IO-GND}	Reverse Bias = 0 V, $f = 1 \text{ MHz}$		2.0		pF
		$V_{CC} = 5 \text{ V}$, Reverse Bias = 2.5 V, $f = 1 \text{ MHz}$		1.0	1.5	

Note:

- Parameter is guaranteed by design and/or component characterization.
- Transmission Line Pulse (TLP) with 100 ns width, 0.2 ns rise time, and average window $t_1 = 70 \text{ ns}$ to $t_2 = 90 \text{ ns}$
- Device stressed with ten non-repetitive ESD pulses.

Capacitance vs. Reverse Bias

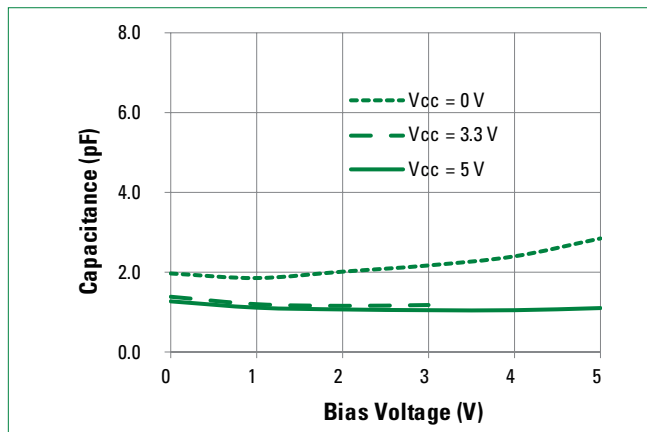

Clamping Voltage vs I_{PP}

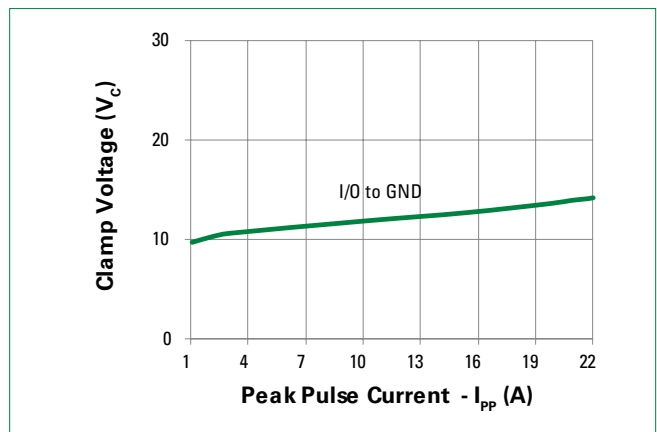

SC3051-04HTG

6 V, 22 A, SOT23-6, Lightning Surge Protection

Positive Transmission Line Pulsing (TLP) Plot

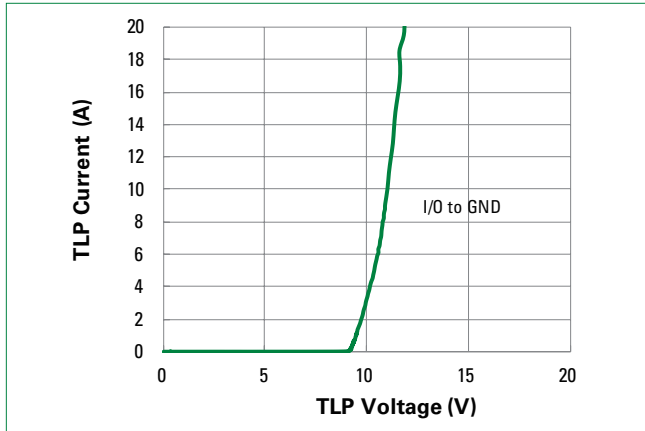

Negative Transmission Line Pulsing (TLP) Plot

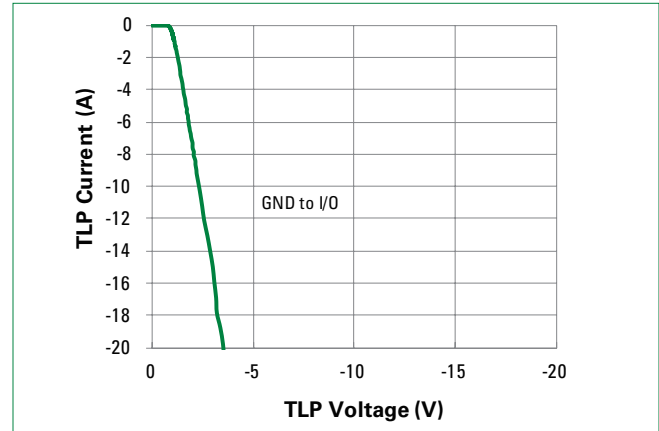

IEC 61000-4-2 +8 kV Contact ESD Clamping Voltage

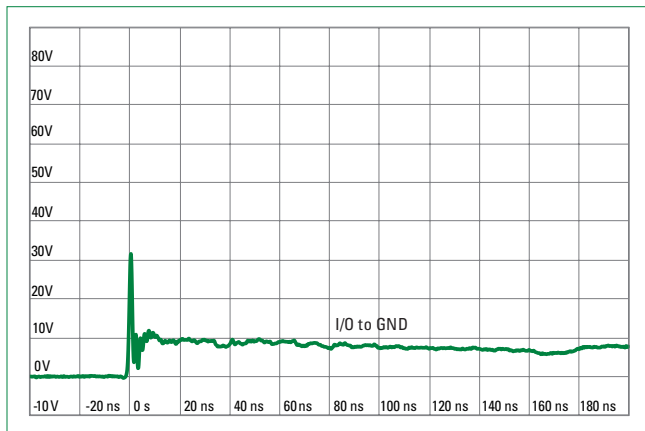

IEC 61000-4-2 -8 kV Contact ESD Clamping Voltage

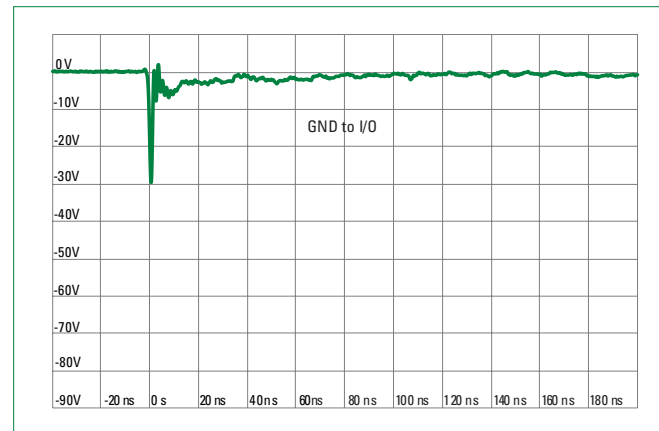

SC3051-04HTG

6 V, 22 A, SOT23-6, Lightning Surge Protection

Soldering Parameters

Reflow Condition		Pb – free assembly
Pre Heat	- Temperature Min ($T_{s(min)}$)	150 °C
	- Temperature Max ($T_{s(max)}$)	200 °C
	- Time (min to max) (t_s)	60 – 120 seconds
Average Ramp Up Rate (Liquidus) Temp (T_L) to Peak		3 °C/second max
$T_{s(max)}$ to T_L - Ramp-up Rate		3 °C/second max
Reflow	- Temperature (T_L) (Liquidus)	217 °C
	- Temperature (t_L)	60 – 150 seconds
Peak Temperature (T_p)		260 ^{+0/-5} °C
Time Within 5°C of Actual Peak Temperature (t_p)		30 seconds
Ramp-down Rate		6 °C/second max
Time 25°C to Peak Temperature (T_p)		8 minutes max
Do Not Exceed		260 °C

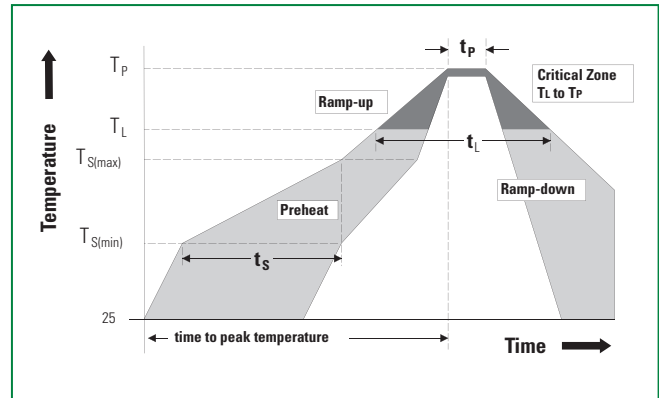

Ordering Information

Part Number	Package	Min. Order Qty.
SC3051-04HTG	SOT23-6	3000

Product Characteristics

Lead Plating	Matte tin
Lead Material	Copper alloy
Body Material	Molded compound
Flammability	UL recognized compound meeting flammability rating V-0

Part Numbering System

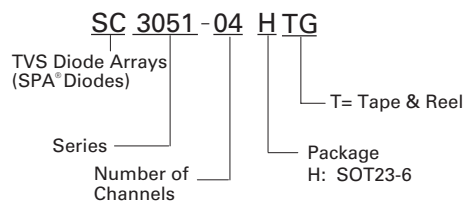

Part Marking System

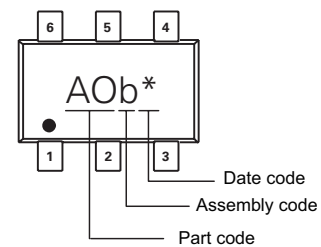

SC3051-04HTG

6 V, 22 A, SOT23-6, Lightning Surge Protection

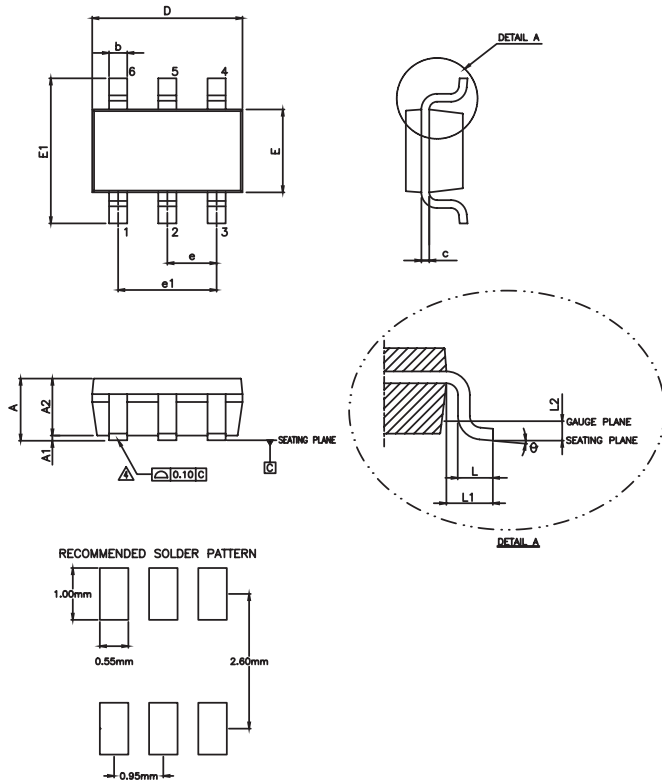
Package Dimensions - SOT23-6

Symbol	Millimeters		Inches	
	Min	Max	Min	Max
A	-	1.45	-	0.057
A1	0.00	0.15	0.000	0.006
A2	0.90	1.30	0.035	0.051
b	0.25	0.50	0.010	0.020
c	0.08	0.22	0.003	0.009
D	2.82	3.02	0.111	0.119
E	1.50	1.70	0.059	0.067
E1	2.60	3.00	0.102	0.118
e	0.95 BSC.		0.037 BSC.	
e1	1.90 BSC.		0.075 BSC.	
L	0.30	0.55	0.012	0.022
L1	0.60 REF.		0.024 REF.	
L2	0.25 REF.		0.010 REF.	
θ	0°	8°	0°	8°

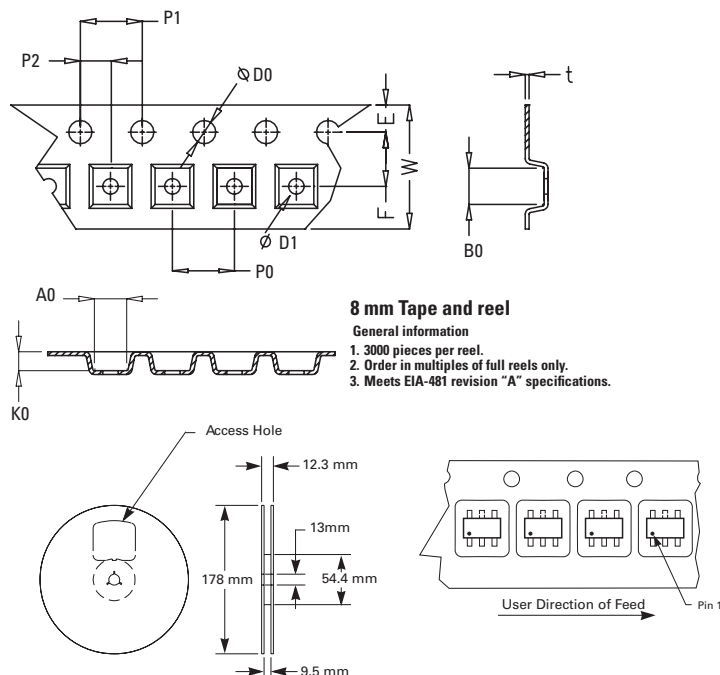
Embossed Carrier Tape & Reel Specification — SOT23-6**8 mm Tape and reel****General information**

- 3000 pieces per reel.
- Order in multiples of full reels only.
- Meets EIA-481 revision "A" specifications.

Symbol	Millimeters
A0	3.17+/-0.10
B0	3.23+/-0.10
W	8.00+0.30/-0.10
D0	1.50+0.10
D1	1.00+0.25
E	1.75+/-0.10
F	3.50+/-0.10
P0	4.00+/-0.10
P1	4.00+/-0.10
P2	2.00+/-0.05
K0	1.37+/-0.10
T	0.25+/-0.03

Disclaimer Notice - Information furnished is believed to be accurate and reliable. However, users should independently evaluate the suitability of and test each product selected for their own applications. Littelfuse products are not designed for, and may not be used in, all applications. Read complete Disclaimer Notice at <http://www.littelfuse.com/disclaimer-electronics>.