

PART NUMBER	UPC NUMBER	PART NUMBER	UPC NUMBER
OMBB050.U	07945863741	OMBB050.L	07945864980
OMBB060.U	07945863742	OMBB060.L	07945864981
OMBB080.U	07945863743	OMBB080.L	07945864982
OMBB100.U	07945863744	OMBB100.L	07945864983
OMBB150.U	07945863745	OMBB150.L	07945864984
OMBB200.U	07945863746	OMBB200.L	07945864985
OMBB250.U	07945863747	OMBB250.L	07945864986
OMBB300.U	07945864025	OMBB300.L	07945864987
OMBB350.U	07945864026	OMBB350.L	07945864988

REVISION		
REV	DATE	DESCRIPTION
A	8/5/25	529224GCP - RELEASE MRY
B	8/6/25	529232ECP/D - UPDATE CENTER-TO-CENTER DIMENSION POSITION MRY
C	12/10/25	529577ECP/D - ADD .L PART NUMBERS AND UPC CODES TO PART TBLE JTM

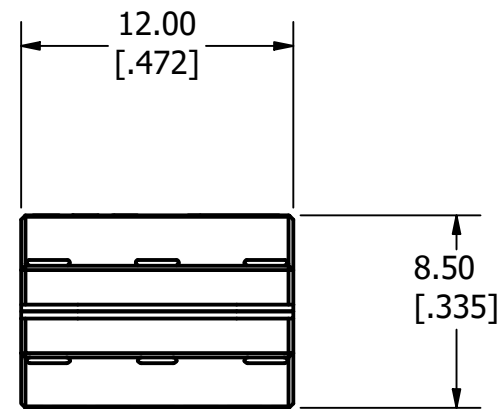
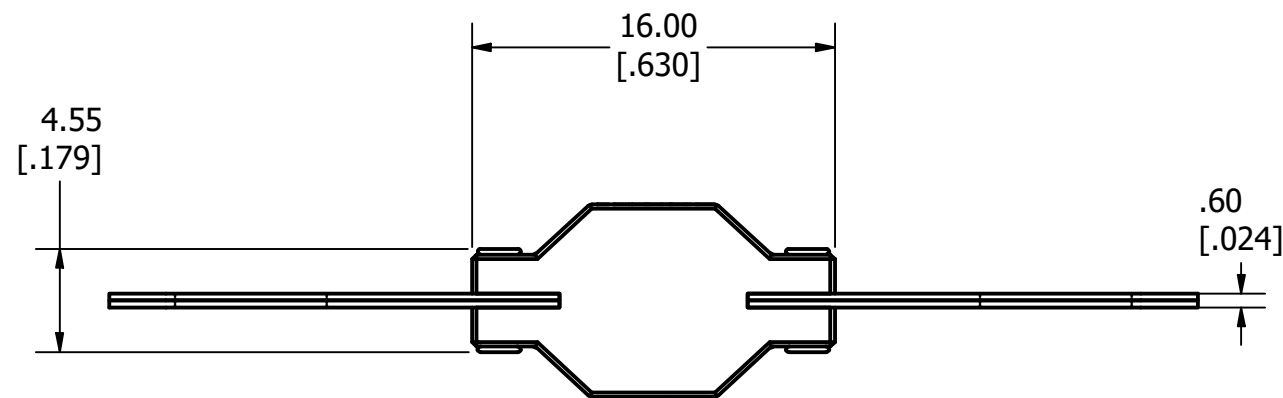
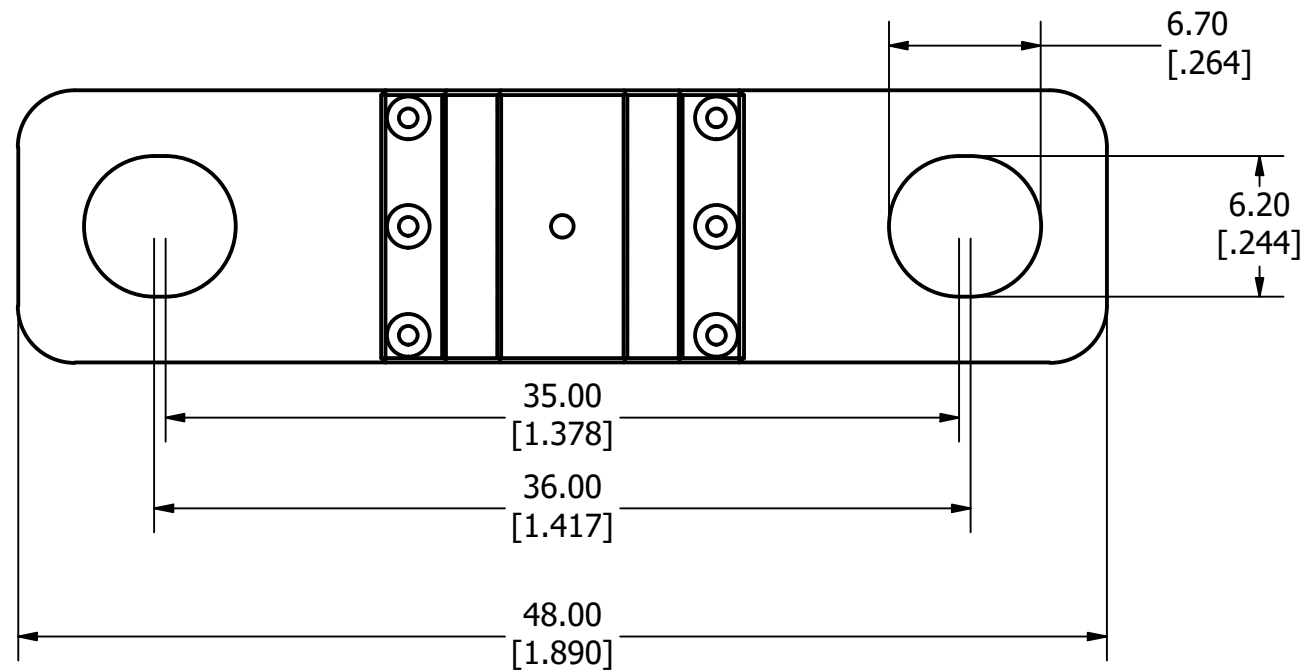

<S>	CRITICAL CHARACTERISTIC FOR PART SAFETY/COMPLIANCE
●	DENOTES CRITICAL CHARACTERISTICS.
CPK	DENOTES CPK DIMENSIONS, -MINIMUM CPK VALUE
⊕	DENOTES A CHARACTERISTIC THAT PROVIDES AN INDICATION OF PROCESS PERFORMANCE. PROCEDURE FOR MEASUREMENT AND TRACKING TO BE DEFINED IN LITTELFUSE INSPECTION INSTRUCTIONS.
CP	DENOTES CP DIMENSIONS, -MINIMUM CP VALUE MUST BE WITHIN THE DIMENSIONAL LIMITATIONS SHOWN ON DRAWING AND INITIALLY LOCATED TO ALLOW FOR MAXIMUM TOOL LIFE.

B

MATL SPEC		FINISH	
DRW M. Fular	DATE 3/13/2025	SCALE NTS	FINISH GOOD WT GRAMS/PIECE

UNLESS OTHERWISE SPECIFIED, DIMENSIONS ARE IN MILLIMETERS, DIMENSIONS IN BRACKETS [] ARE INCHES DIMENSIONING AND DO NOT INCLUDE PLATING. TOLERANCING TO BE INTERPRETED IN ACCORDANCE WITH ANSI Y14.5M-1994

3RD ANGLE PROJECTION	
----------------------	--

TITLE	MBB SERIES OUTLINE
-------	--------------------

Littelfuse CHICAGO, ILLINOIS 60631	REVISION C	DRWG NO. OL-0MBB000	SHEET 1 OF 1
--	----------------------	-------------------------------	--------------