

PART NUMBER

OLD45533ZX

REVISION		
REV	DATE	DESCRIPTION
A	3/11/24	527585GCP - RELEASE PER EM3406 MRY

NOTES:

1. AGENCY INFORMATION: cULus - UL LISTED TO UL 1953
UL EVALUATED TO CSA 22.2 NO. 158
2. MATERIALS: INSULATOR BASE: HIGH IMPACT THERMOPLASTIC
FLAMMABILITY RATING UL94V0
TEMP RATING: -40°C TO 125°C (UL RTI)
CONNECTOR: ALUMINUM, TIN PLATED
LINE TERMINAL SCREWS: ALUMINUM, TIN PLATED
LOAD TERMINAL SCREWS: ALUMINUM, NICKEL PLATED
CONNECTOR MOUNTING SCREWS: STEEL, ZINC PLATED
3. TERMINATION: LINE: COPPER STRANDED & ALUMINUM, 350 KCMIL - #6 AWG
LOAD: COPPER STRANDED, #2 - 14 AWG
SOLID COPPER, #10 - 14 AWG
ALUMINUM, #2 - 6 AWG
4. MAXIMUM AMP RATING PER POLE: 335A
BASED ON NEC WIRE RATING CODE, 75°C WIRE
PROVIDES SPACING FOR USE IN FEEDER CIRCUITS
AT 251-600V PER UL508A
5. TORQUE: LINE: 400 KCMIL - #6: 31 N-m (275 lbf-in)
LOAD: #2: 5.6 N-m (50 lbf-in)
#4 - 6: 5.1 N-m (45 lbf-in)
#8: 4.5 N-m (40 lbf-in)
#10 - 14: 4 N-m (35 lbf-in)
6. MOUNTING: USE #10 FASTENER. TORQUE NOT TO EXCEED
3.4 N-m (30 lbf-in).

TOLERANCE (UNLESS OTHERWISE SPECIFIED):

- 1 PLACE ± 2.5mm [0.10]
- 2 PLACE ± 0.76mm [0.03]
- 3 PLACE ± 0.381mm [0.015]

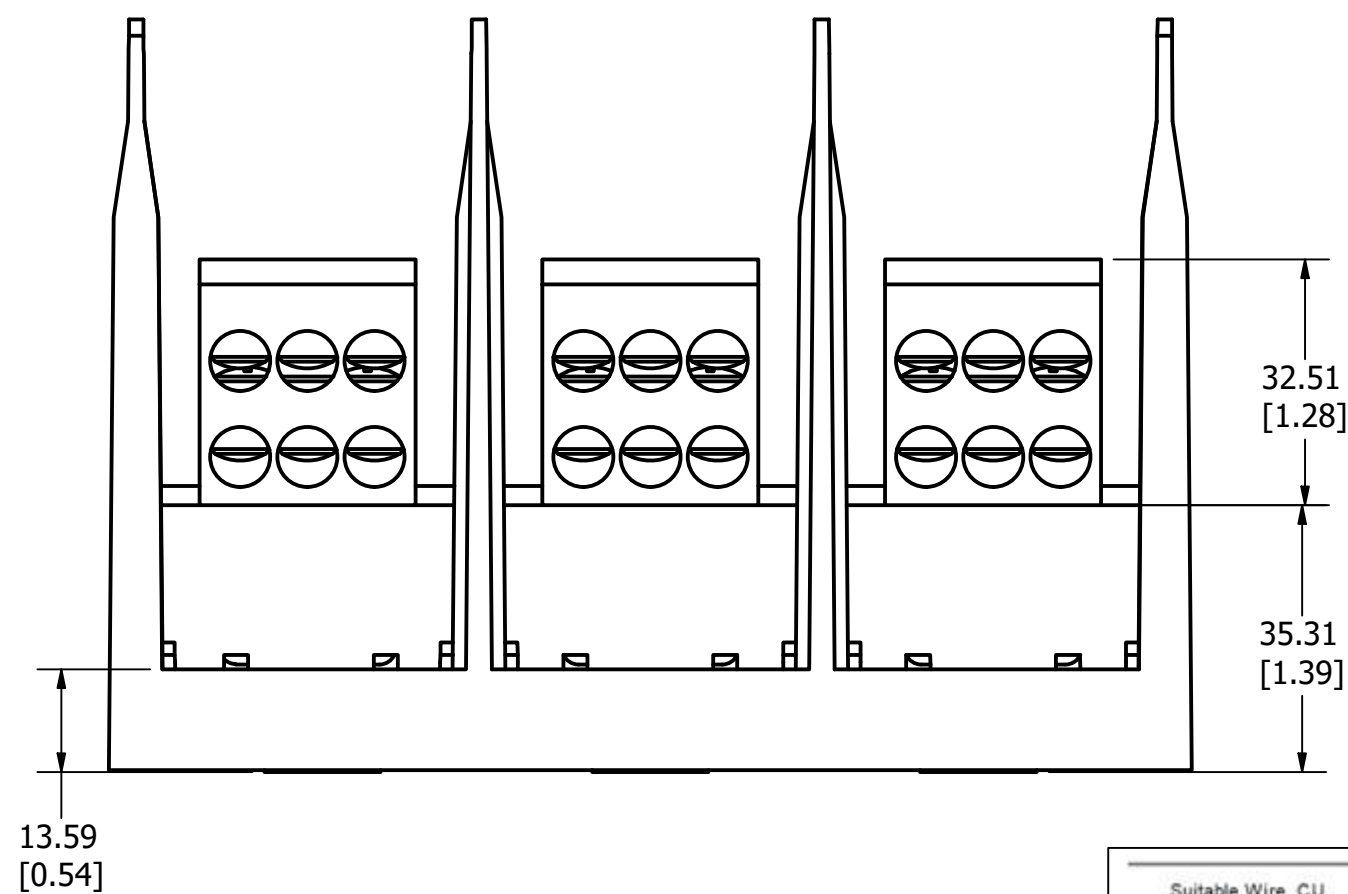
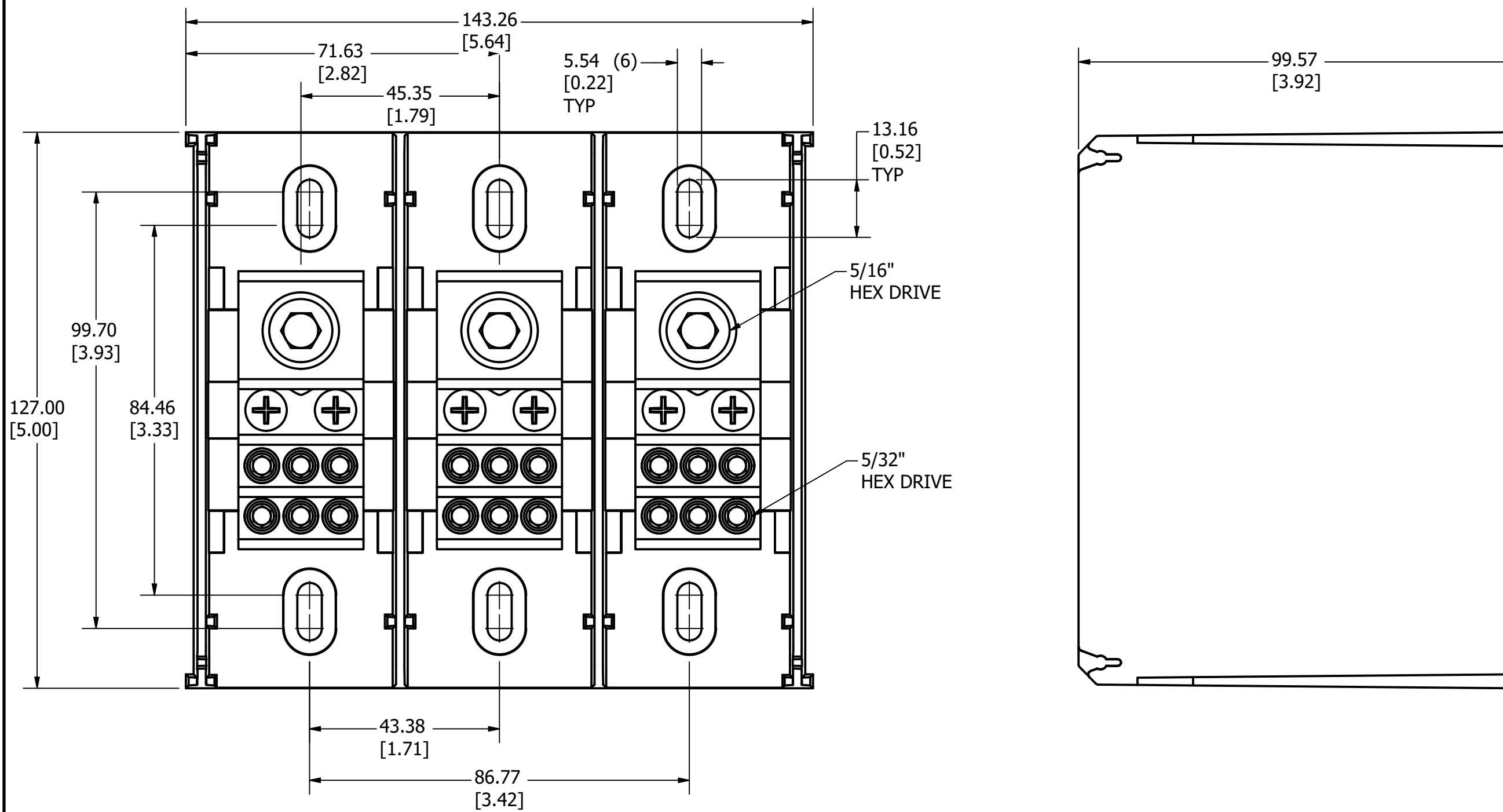

CLASS	LINE	LOAD	Over-Current Protection Fuse Required				SCCR RMS Sym. Amps 600V Max
			J	T	RK1	RK5	
B-C	400-3/0	2-6	600	600	200	60	100,000
	400-6	2-10	300	300	100	60	100,000
G,H,I	400-6	2-14	110	110	30	60	100,000
	250-1/0	4-10	400	400	100	60	100,000
	250-2	4-14	125	125	30	60	100,000
	400-6	4-14	None				10,000

PRODUCT LABELS

NO	COMPONENT NO	DESCRIPTION	QTY/M	U/M
BILL OF MATERIAL				
<S>		CRITICAL CHARACTERISTIC FOR PART SAFETY/COMPLIANCE		
●		DENOTES CRITICAL CHARACTERISTICS.		
CPK		DENOTES CPK DIMENSIONS, -MINIMUM CPK VALUE		
(ST)		DENOTES A CHARACTERISTIC THAT PROVIDES AN INDICATION OF PROCESS PERFORMANCE. PROCEDURE FOR MEASUREMENT AND TRACKING TO BE DEFINED IN LITTELFUSE INSPECTION INSTRUCTIONS.		
CP		DENOTES CP DIMENSIONS, -MINIMUM CP VALUE MUST BE WITHIN THE DIMENSIONAL LIMITATIONS SHOWN ON DRAWING AND INITIALLY LOCATED TO ALLOW FOR MAXIMUM TOOL LIFE.		C
MATL SPEC		FINISH		
DRW myork	DATE 3/2/2023	SCALE NTS	FINISH GOOD WT GRAMS/PIECE	
UNLESS OTHERWISE SPECIFIED, DIMENSIONS ARE IN MILLIMETERS, DIMENSIONS IN BRACKETS [] ARE INCHES DIMENSIONING AND DO NOT INCLUDE PLATING. TOLERANCING TO BE INTERPRETED IN ACCORDANCE WITH ANSI Y14.5M-1994				
3RD ANGLE PROJECTION				
TITLE DISTRIBUTION BLOCK 600V, 335A, 3 POLE OUTLINE				
Littelfuse CHICAGO, ILLINOIS 60631		REVISION A	DRWG NO. OL-LD45533	SHEET 1 OF 1