

TIME DELAY RELAYS

The largest selection of time delay relays known since 1968 for its reliable designs that provide long service lives with low maintenance costs. Versatile multifunction time delay relays give you the option of choosing among functions and time delay ranges to ensure that you receive the perfect timer to fit your needs. Electromechanical relay-output time delay relays are available with a number of different functions and assure isolation between input and output, as well as no voltage drop across output contact. Solid-state time delay relays have no moving parts to arc and wear out over time, giving them a lifespan of up to 100x that of a relay-output timer. In addition, all solid state time delay relays are fully encapsulated to protect against shock, vibration, humidity, etc.

Timer Function Guide 278

Multifunction

TRDU Series 279
 TRU Series 282
 ASQU / ASTU Series 284
 DSQU / DSTU Series 286

Dedicated

On Delay

T10 SERIES 288

Delay-on-Make

ERDM Series 289
 HRDM Series 291
 KRDM Series 293
 KRPS Series 295
 KSD1 Series 298
 KSDU Series 300
 KSPS Series 302
 MSM Series 305
 ORM Series 307
 PRLM Series 309
 TDM / TDMH / TDML Series 311
 TDU / TDUH / TDUL Series 313
 TH1 Series 315
 THD1B410.5S 317
 TMV8000 / TSU2000 Series 319
 TRM Series 321
 TS1 Series 323
 TSD1 Series 325

Delay-on-Make, Normally Closed

TS441165 327

Delay-on-Break

HRDB Series 329
 HRPS / HRIS Series 331
 KRDB Series 333
 KSDB Series 335
 ORB Series 337
 TDB / TDBH / TDBL Series 339
 TDUB Series 341
 THDB Series 343
 TRB Series 345
 TSB Series 347
 TSDB Series 349

Single Shot

HRDS Series 351
 HSPZA22SL 353
 KRDS Series 355
 KSDS Series 357
 ORS Series 359
 PRS65 361
 TDS / TDSH / TDSL Series 362
 TDUS Series 364
 THC / THS Series 366
 THDS Series 368
 TRS Series 370
 TSDS Series 372
 TSS Series 374

Interval

ERDI Series.....	376
HRDI Series.....	378
KRDI Series.....	380
KSD2 Series.....	382
KSPU Series.....	384
TDI / TDIH / TDIL Series.....	386
TDUI / TDUIH / TDUIL Series.....	388
THD2 Series.....	390
THD7 Series.....	392
TS2 / TS6 Series.....	394
TSD2 Series.....	396
TSD6 Series.....	398
TSD7 Series.....	400

Retriggerable Single Shot

KRD9 Series.....	402
TSD94110SB.....	404

Recycle

ERD3425A.....	405
ESDR Series.....	407
HRDR Series.....	410
KRD3 Series.....	412
KRDR Series.....	414
KSD3 Series.....	416
KSDR Series.....	418
KSPD Series.....	420
RS Series.....	422
TDR Series.....	424
THD3C42A0.....	426
TSD3411S.....	428
TSDR Series.....	430

Percentage

PTHF4900DK.....	432
-----------------	-----

Dual Function

TDMB Series.....	434
ESD52233.....	436
KRPD Series.....	438

HVAC

CT Series.....	440
T2D120A15M.....	442
TA Series.....	444
TAC1 Series.....	446
TL Series.....	448
TSA141300.....	450

Coin Vending

HRV Series.....	451
-----------------	-----



For More Information...
and to download our HVAC Timer
Application Guide, visit
Littelfuse.com/timedelayrelays

TIMER FUNCTION GUIDE

Selecting a Timer's Function

Selecting one of the five most common timing functions can be as easy as answering three questions on the chart below. If you have trouble answering these questions, try drawing a connection diagram that shows how the timer and load are connected. Time diagrams and written descriptions of the five most popular functions, plus other common functions. Instantaneous contacts, accumulation, pause timing functions, and flashing LED's are included in some units to expand the versatility of the timer. These expanded operations are explained on the product's catalog page. Time diagrams are used on these pages along with text and international symbols for functions.

Function Selection Guide

Selection Questions

- The timing starts when the initiate (starting) contacts are:
 - Closed
 - Opened
- What is the status of the output (or load) during timing?
 - On
 - Off
 - On/Off
- Will the load de-energize (or remain de-energized) if the initiate (starting) contacts are opened during timing?
 - Yes
 - No

THE FIVE MOST USED FUNCTIONS

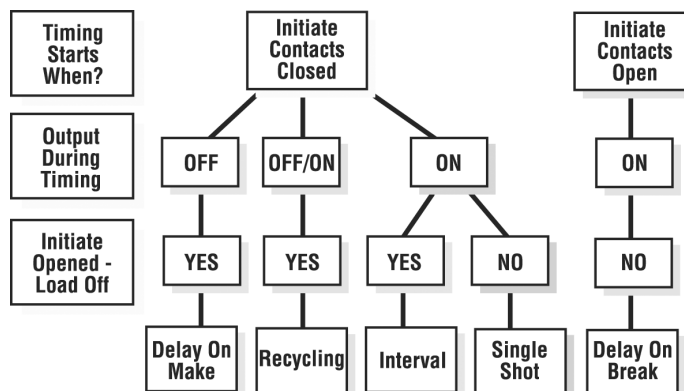

Understanding Time Diagrams

Time diagrams are used to show the relative operation of switches, controls, and loads as time progresses. Time begins at the first vertical boundary. There may be a line indicating the start of the operation or it may just begin with the transition of the device that starts the operation. Each row in the time diagram represents a separate component. These rows will be labeled with the name of the device or its terminal connection numbers. In a bistable or digital system, the switches, controls, or loads can only be ON or OFF. The time lines are drawn to represent these two possible conditions. Vertical lines are used to define important starting or ending points in the operation.

The example to the right is the most common type of time diagram in use in North America. It shows the energizing of loads, and the closing of switches and contacts by an ascending vertical transition of the time line. Opening switches or contacts or de-energizing loads are represented by descending vertical transitions.

TIME DIAGRAM

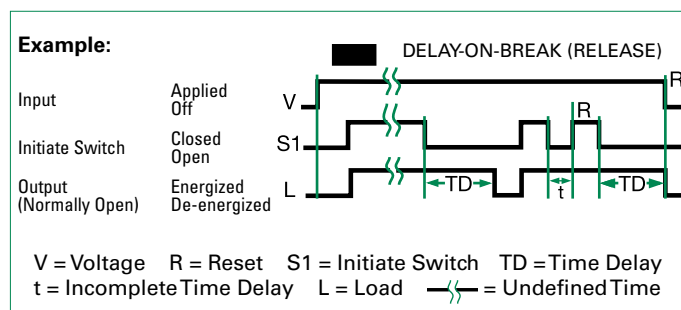

International Timing Function Symbols

- ☒ = Delay-on-Make; ON-delay
- = Delay-on-Break; OFF-delay
- ☒ ■ = Delay-on-Make and Break; ON and OFF-delay
- 1 □ = Interval; Impulse-ON
- 1 □ = Trailing Edge Interval; Impulse-OFF
- = Single Shot; Pulse Former
- = Flasher - ON Time First; Recycling Equal Times - ON First
- ■ = Flasher - OFF Time First; Recycling Equal Times - OFF First
- ☒ = Recycling - Unequal Times; Pulse Generator
- ☒ = Recycling - Unequal Times Starting with ON or OFF
- ☒ = Delay-on-Make and Interval; Single Pulse Generator

TRDU SERIES



8-PIN



11-PIN

Wiring Diagram

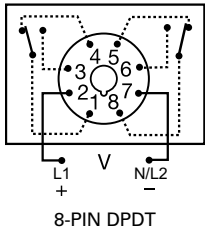

8-PIN DPDT

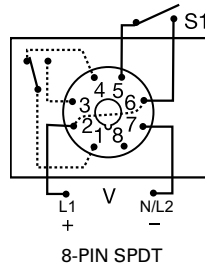

8-PIN SPDT

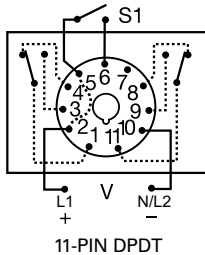

11-PIN DPDT

V = Voltage
S1 = Initiate Switch

For dimensional drawing see: Appendix, page 512, Figure 20.

Ordering Information

MODEL	INPUT VOLTAGE	BASE CONNECTION
TRDU120A1	120VAC	8-pin, DPDT*
TRDU120A2	120VAC	8-pin, SPDT
TRDU120A3	120VAC	11-pin, DPDT
TRDU12D1	12VDC	8-pin, DPDT*
TRDU12D2	12VDC	8-pin, SPDT
TRDU230A2	230VAC	8-pin, SPDT
TRDU24A1	24VAC/DC	8-pin, DPDT*
TRDU24A2	24VAC/DC	8-pin, SPDT
TRDU24A3	24VAC/DC	11-pin, DPDT

If you don't find the part you need, call us for a custom product 800-843-8848

*Limited to 9 operating functions in 8-pin DPDT units.

Description

The TRDU Series is a versatile universal time delay relay with 21 selectable single and dual functions. The dual functions replace up to three timers required to accomplish the same function. Both the function and the timing range are selectable with switches located on the face of the unit. Two LED's indicate input voltage and output status. This device offers full 10A isolated relay output contacts in either SPDT or DPDT. The TRDU replaces hundreds of part numbers, thereby, reducing your stock inventory requirements.

21 Functions

Five switches are provided to set one of 10 single or 11 dual modes of operation.

Features & Benefits

FEATURES	BENEFITS
21 timing functions	Replace hundreds of parts and reduce stocking requirements
Microcontroller based	Repeat Accuracy +/- 0.1%
User selectable time delay	Timing settings are switch selectable 0.1s - 1,705h in eight ranges for added flexibility
Isolated 10A, SPDT or DPDT output contacts	Allows control of loads for AC or DC voltages
LED indicators	Provides visual indication of input voltage and relay status

Accessories



BZ1 Front Panel Mount Kit

Provides an easy method of through-the-panel mounting of 8- or 11-pin plug-in timers, flashers, and other controls.



NDS-8 Octal 8-pin Socket

8-pin 35mm DIN rail or surface mount. Surface mounted with two #6 screws or snaps onto a 35 mm DIN rail. Uses PSC8 hold-down clips.



NDS-11 11-pin Socket

11-pin 35mm DIN rail or surface mount. Surface mounted with two #6 screws or snaps onto a 35 mm DIN rail. Uses PSC11 hold-down clips.



PSC8 or PSC11 Hold-down Clips

Securely mounts plug-in controls in any position. Provides protection against vibration. Use PSC8 with NDS-8 Octal Socket or PSC11 with NDS-11 Socket. Sold in sets of two.



C103PM (AL) DIN Rail

35 mm aluminum DIN rail available in a 36 in. (91.4 cm) length.

TRDU SERIES

Specifications

Time Delay

Type Microcontroller
Range: Switch Selectable** Single Functions: 0.1s - 1,705h in 8 ranges
 Dual Functions: 0.1s - 3,100m each in 8 ranges
Adjustments Multiplier: 3 position DIP switches select 0.1, 1, 10, or 100 in s or m

Setting Accuracy ±1% or 50ms, whichever is greater
Repeat Accuracy ±0.1% or 20ms, whichever is greater
Timing Functions Five switches are provided to set one of twenty-one single or dual functions
 ≤ 50ms
 120VAC: 75ms

Reset Time
Initiate Time
Time Delay vs Temp. & Voltage ±1%

Indication **Two LEDs indicate** 1) Input voltage applied 2) Output relay status

Input Voltage 12VDC, 24VAC/DC, 120VAC, or 230VAC

Tolerance -15% - 20%
 -20% - 10%

AC Line Frequency 50/60Hz
Power Consumption 24 to 230V ≤ 3W; 12VDC ≤ 2W

Output Type Electromechanical relay
Form SPDT or DPDT
Rating 10A resistive @ 120/240VAC & 28 VDC;
 1/3 hp @ 120/240VAC
Life Mechanical – 1 x 10⁷; Electrical – 1 x 10⁶

Protection

Isolation Voltage ≥ 1500V RMS input to output
Insulation Resistance ≥ 100 MΩ
Polarity DC units are reverse polarity protected

Mechanical

Mounting Dimensions Plug-in socket
H 76.7 mm (3.1"); **W** 60.7 mm (2.39");
D 45.2 mm (1.78")
 Octal 8-pin plug-in or magnal 11-pin plug-in

Termination

Environmental
Operating/Storage Temperature -20° to 65°C / -40° to 85°C
Weight ≈ 5.8 oz (164 g)

**For CE approved applications, power must be removed from the unit when a switch position is changed.

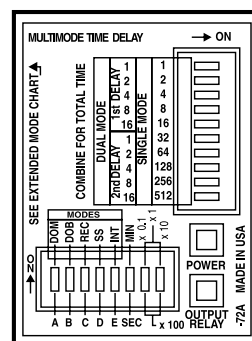

Function Diagrams

Single Functions

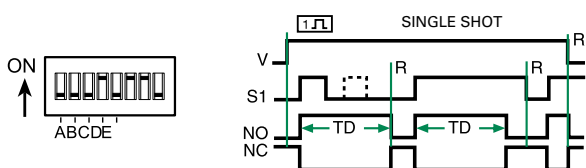
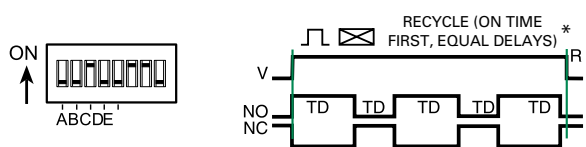
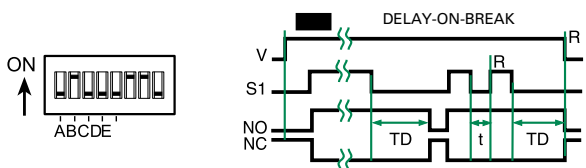
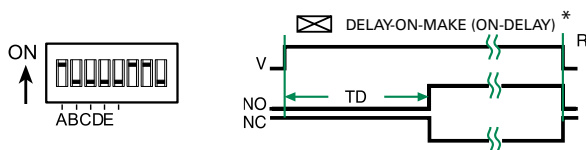

Dual Functions

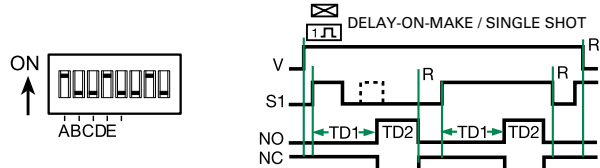
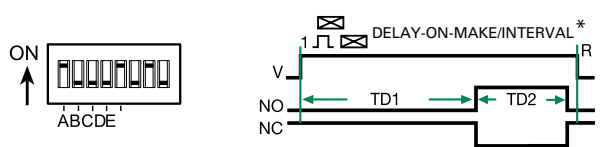
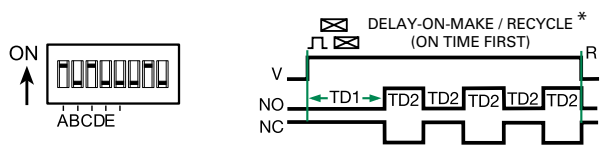
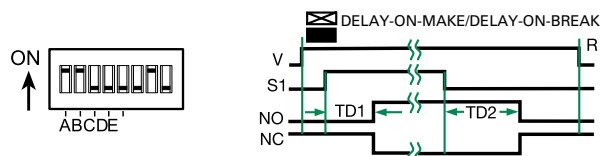

12 TIME DELAY RELAYS

TRDU SERIES

Single Functions

Dual Functions

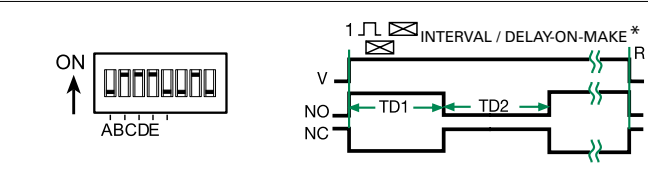
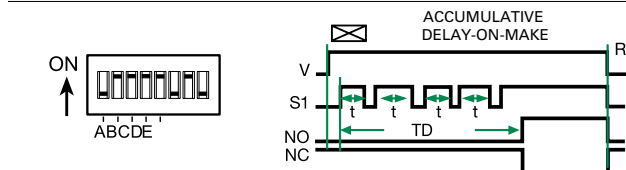
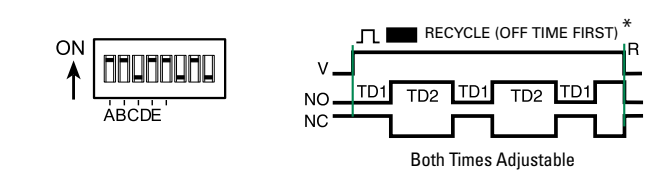
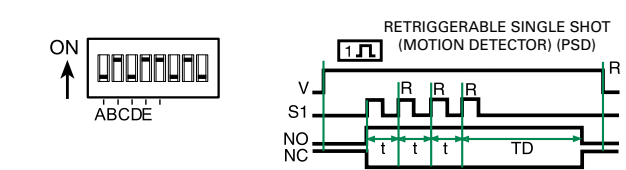
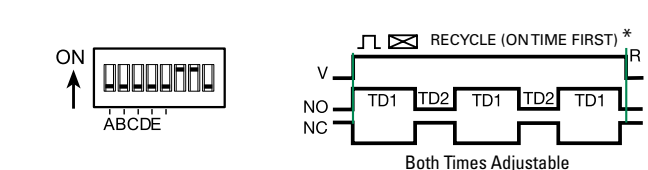
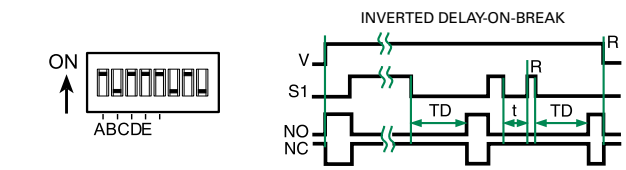
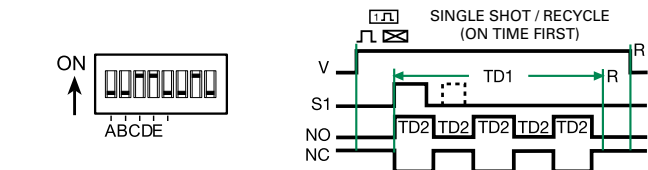
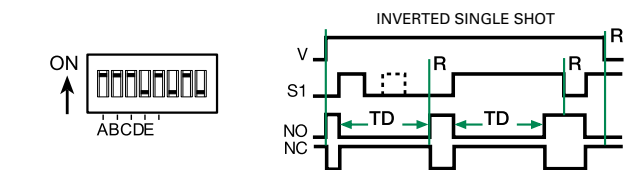
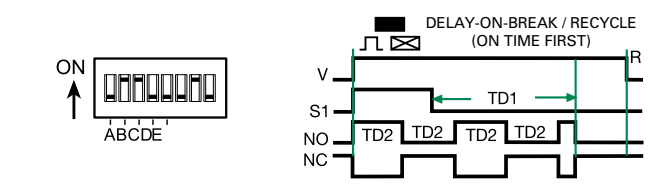
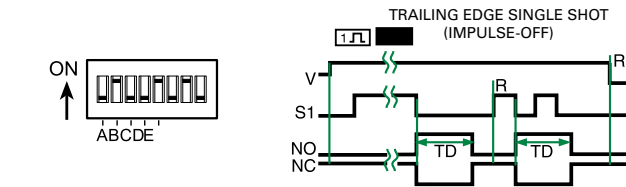
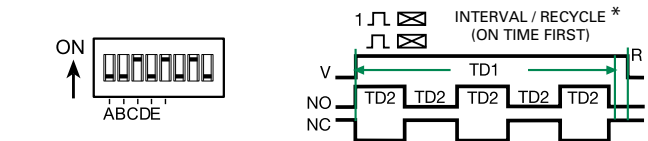
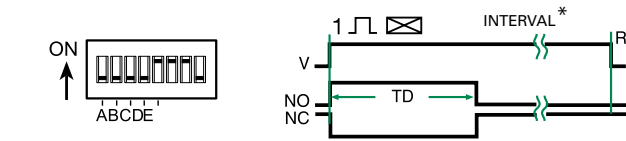

KEY

LEGEND

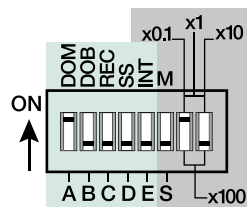

- V = Voltage
- R = Reset
- S1 = Initiate Switch
- NO = Normally Open Contact
- NC = Normally Closed Contact
- TD, TD1, TD2 = Complete Time Delay
- t = Partial Time Delay
- DOM = Delay-on-Make
- DOB = Delay-on-Break
- REC = Recycle
- SS = Single Shot
- INT = Interval
- M = Minutes
- S = Seconds
- = Undefined time

- 5 Switches for Function Selection
- 3 Switches for Time Delay Range

* 9 Functions included in the 8 pin DPDT models

NOTE: The time delay range is the same for both functions when dual functions are selected.

TRU SERIES

Knob Adjustable Universal Time Delay Relay



8-PIN



11-PIN

Description

The TRU Series is a multifunction, knob adjustable, Universal Time Delay Relay. It includes six of the most popular timing functions selected by a slide switch. The time delay is knob adjustable and the time delay range is switch selectable. The repeat accuracy is + 0.1%. Both function and time range can be selected on the top face of the unit. In addition to multifunctioning and multiple time ranges, the TRU Series features universal input voltage; 19 to 264VAC and 19 to 30VDC and full 10A output relay. The TRU Series can directly replace up to 1000 competitive time delay relay models.

Operation

A six position slide switch selects delay-on-make, interval, single shot, recycling (ON time first, equal recycle delays), delay-on-break, and retriggerable single shot. 8-pin DPDT base wiring is limited to delay-on-make, interval, and recycling functions. All six functions are available in the 8-pin SPDT and 11-pin DPDT versions.

Wiring Diagram

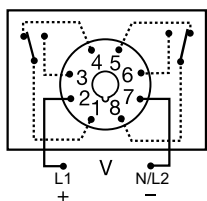

8-PIN DPDT
Delay-on-Make
Interval
Recycling

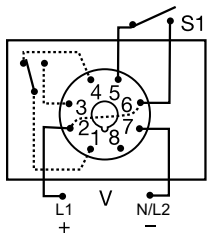

8-PIN SPDT
Delay-on-Make
Interval
Single Shot
Recycling
(ON Time First, Equal
Recycle Delays)
Delay-on-Break
Retriggerable Single Shot

V = Voltage
S1 = Initiate Switch

Relay contacts
are isolated

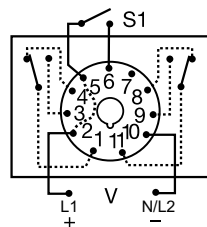

11-PIN DPDT
Delay-on-Make
Interval
Single Shot
Recycling
(ON Time First, Equal
Recycle Delays)
Delay-on-Break
Retriggerable Single Shot

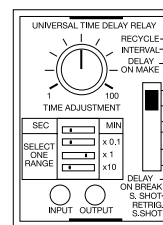

Features & Benefits

FEATURES	BENEFITS
Microcontroller based	Repeat Accuracy +/- 0.1% or +/- 20ms, whichever is greater
6 time ranges (0.1s to 1,000m)	Broad range will satisfy most requirements
Knob adjustable time delay	Allows user to fine tune time delay based on application needs
Universal input voltage	Makes it versatile for use in most applications
Multifunction	Provides the most common standard timing functions
LED Indicators	Provide visual indication of input voltage and relay status
10A isolated output contacts	Allows control of loads for AC or DC voltages

For dimensional drawing see: Appendix, page 512, Figure 21.

Ordering Information

MODEL	INPUT VOLTAGE	BASE WIRING	FUNCTIONS
TRU1	19 to 264VAC; 19 to 30VDC	8-pin DPDT	3
TRU2	19 to 264VAC; 19 to 30VDC	8-pin SPDT	6
TRU3	19 to 264VAC; 19 to 30VDC	11-pin DPDT	6

If you don't find the part you need, call us for a custom product 800-843-8848

12 TIME DELAY RELAYS

TRU SERIES

Accessories

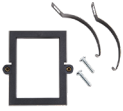

BZ1 Front Panel Mount Kit
Provides an easy method of through-the-panel mounting of 8- or 11-pin plug-in timers, flashers, and other controls.



NDS-8 Octal 8-pin Socket
8-pin 35mm DIN rail or surface mount. Rated at 10A @ 300VAC. Surface mounted with two #6 (M 3.5 x 0.6) screws or snaps onto a 35 mm DIN rail. Uses PSC8 hold-down clips.



NDS-11 11-pin Socket
11-pin 35mm DIN rail or surface mount. Rated at 10A @ 300VAC. Surface mounted with two #6 (M 3.5 x 0.6) screws or snaps onto a 35 mm DIN rail. Uses PSC11 hold-down clips.



PSC8 or PSC11 Hold-down Clips
Securely mounts plug-in controls in any position. Provides protection against vibration. Use PSC8 with NDS-8 Octal Socket or PSC11 with NDS-11 Socket. Sold in pairs.

Function Diagram

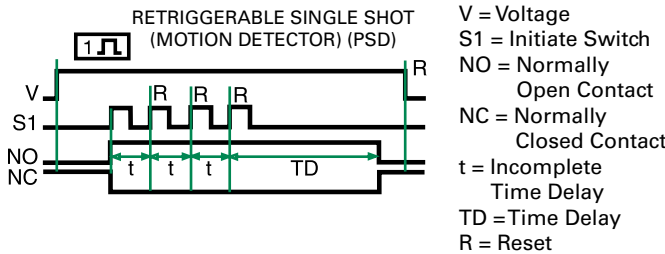

Specifications

Time Delay

Type
Range
Switch Selectable

Digital integrated circuitry

0.1s - 1000m in 6 ranges:

- 1) 0.1 - 10s
- 2) 1 - 100s
- 3) 10 - 1000s
- 4) 0.1 - 10m
- 5) 1 - 100m
- 6) 10 - 1000m

Adjustments

Multiplier

4 position DIP switch selects x0.1, x1, x10, and sec. or min.

Time Setting

Onboard knob adjustment with 1 - 100 reference dial

Two LEDs indicate

- 1) Input voltage applied
- 2) Output relay status

Repeat Accuracy

±0.1% or ±20ms, whichever is greater

Reset Time

≤ 300ms

Time Delay vs Temp. & Voltage

±2%

Input

Voltage - Universal

Input Range

19 to 264VAC and 19 to 30VDC

AC Line Frequency

50/60Hz

Output

Type

Electromechanical relay

Form

SPDT or DPDT, isolated

Rating

10A resistive @ 120/240VAC & 28VDC;
1/3 hp @ 120/240VAC
Mechanical - 1×10^7 ; Electrical - 1×10^6

Life

Protection

38 joules

Transient

≥ 1500V RMS input to output

Isolation Voltage

DC units are reversed polarity protected

Polarity

Mechanical

Mounting

Plug-in socket

Dimensions

H 87.3 mm (3.44"); **W** 60.7 mm (2.39");
D 45.2 mm (1.78")

Termination

Octal 8-pin plug-in or magnal 11-pin plug-in

Environmental

Operating/Storage

-20° to 65°C / -30° to 85°C

Temperature

Weight

≈ 6 oz (170 g)

ASQU / ASTU SERIES



ASQU

ASTU

Description

The ASQU and ASTU Series of 17.5 mm, knob adjustable, universal solid-state timers offer multiple functions, voltages, and time delay ranges. Choose one of 5 functions and 4 time delay ranges via 4 selection switches located on face of the unit. Adjustment through the time range is accomplished by an onboard knob.

The ASQU Series has quick connect terminals and the ASTU Series has terminal blocks.

Features & Benefits

FEATURES	BENEFITS
Universal AC or DC voltage	Choose from 24 to 240VAC or 9 to 110VDC models
Compact 17.5mm size	Allows for high rail density
Microcontroller based	Repeat Accuracy +/- 1%
Multifunction: 5 timing functions	Reduce stocking requirements
Knob Adjustable Time Delay	Field adjustable delay ranging from 0.1s - 100m
0.7A steady, 10A inrush solid-state output	Provides 100 million operations in typical conditions.
Mounting fasteners included	Each unit ships with both surface and DIN rail quick mount adapters
Watchdog circuitry	Self monitoring and self correcting for improved performance

Wiring & Adjustment Diagrams

DELAY-ON-MAKE & RECYCLING

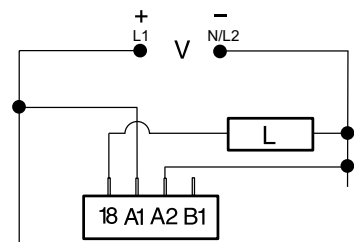

ADJUSTMENTS

DOM	A <input type="checkbox"/>	B <input type="checkbox"/>
SS	A <input type="checkbox"/>	B <input type="checkbox"/>
R	A <input type="checkbox"/>	B <input type="checkbox"/>
DOB	A <input type="checkbox"/>	B <input type="checkbox"/>

DOM = Delay-on-Make
SS = Single Shot/Interval
R = Recycling
DOB = Delay-on-Break

SINGLE SHOT, INTERVAL & DELAY-ON-BREAK

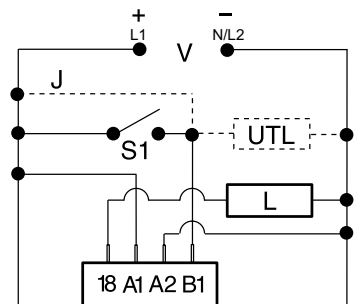

R	M	S
0.1-10s	X1s	C <input type="checkbox"/> E D <input type="checkbox"/> F
1-100s	X10s	C <input type="checkbox"/> E D <input type="checkbox"/> F
10-1000s	X100s	C <input type="checkbox"/> E D <input type="checkbox"/> F
1-100m	X10m	C <input type="checkbox"/> E D <input type="checkbox"/> F

R = Range
M = Multiplier
S = Setting

V = Voltage
L = Load
J = Wire Required for Interval Operation
S1 = Initiate Switch
UTL = Optional Untimed Load

Accessories



P1015-13 (AWG 10/12), **P1015-64** (AWG 14/16), **P1015-14** (AWG 18/22) **Female Quick Connect**

These 0.25 in. (6.35 mm) female terminals are constructed with an insulator barrel to provide strain relief.



P0500-178 Surface Mount Adapter
P0500-179 DIN Rail Mount Adapter

For use with the ASxx/DSxx Series timers.

Ordering Information

MODEL	INPUT VOLTAGE	CONNECTION
ASQUA3	24 to 240VAC	Quick Connects
ASQUD3	9 to 110VDC	Quick Connects
ASTUA3	24 to 240VAC	Terminal Blocks
ASTUD3	9 to 110VDC	Terminal Blocks

If you don't find the part you need, call us for a custom product 800-843-8848

12
TIME DELAY RELAYS

For dimensional drawing see: Appendix, page 512, Figure 22.

ASQU / ASTU SERIES

Specifications

Time Delay

Type Microcontroller based with ceramic resonator and watchdog circuitry

Adjustment Knob with dial; 2 switches select 1 of 4 multipliers

Range* 0.1 - 10s, 1 - 100s, 10 - 1000s, 1 - 100m

Repeat Accuracy ±1% or ±50ms, whichever is greater

Tolerance (Factory Calibration) ±2% or ±50ms, whichever is greater

Reset Time ≤ 300ms

Initiate Time Single Shot & Delay-on-Break: ≤ 32ms

Time Delay vs Temp. & Voltage ±2%, or ±50ms, whichever is greater

Input

Voltage AC: 24 to 240VAC; -20% - 10%
DC: 9 to 110VDC; -0% - 20% @ -25°C
9.4 to 110VDC; -0% - 20% @ -40°C

AC Line Frequency/DC Ripple 50/60Hz / ≤ 10%

Output

Type Solid state

Form NO

Rating 0.7A steady state, 10A inrush

Voltage Drop AC ≈ 2.5V @ 0.7A; DC ≈ 1.5V @ 0.7A

Protection

Surge IEEE C62.41-1991 Level A

Circuitry Encapsulated

Dielectric Breakdown ≥ 2000V RMS terminals to mounting surface

Polarity DC units are reverse polarity protected

Mechanical

Mounting Two base adaptors are available
DIN Rail Snap on to 32 mm DIN 1 & 35 mm DIN 3 rail
Surface Two #6 (M3.5 x 0.6) screws or quick mount fasteners

Dimensions **H** 76.2 mm (3.0"); **W** 17.52 mm (0.69");
D 61.2 mm (2.41")

Termination

ASQU 0.25 in. (6.35 mm) male quick connect terminals

ASTU 0.197 in. (5 mm) push-on terminal blocks for up to #14 AWG (2.5 mm²) wire

Environmental

Operating/Storage Temperature -40° to 60°C / -40° to 85°C

Humidity 95% relative, non-condensing

Weight ≈ 4 oz (113 g)

*For CE approved applications, power must be removed from the unit when a switch position is changed.

Mounting Diagrams

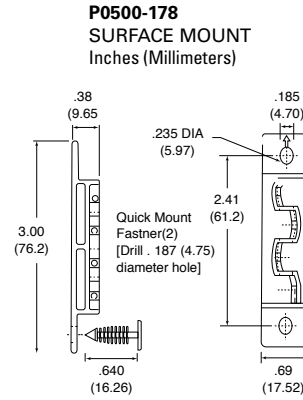

P0500-179
DIN RAIL MOUNT
Inches (Millimeters)

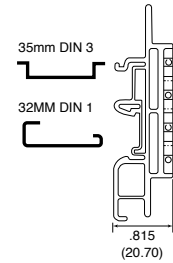

DSQU / DSTU SERIES



DSQU



DSTU

Description

The DSQU and DSTU Series of 17.5 mm, DIP switch adjustable, universal solid-state timers offer multiple functions, voltages, and time delay ranges. Choose one of 5 functions and 4 time delay ranges via 4 selection switches located on face of the unit. Six switches adjust the time delay through the selected range.

The DSQU Series has quick connect terminals and the DSTU Series has terminal blocks.

Features & Benefits

FEATURES	BENEFITS
Universal AC or DC voltage	Choose from 24 to 240VAC or 9 to 110VDC models
Compact 17.5mm size	Allows for high rail density
Microcontroller based	Repeat Accuracy +/- 1%
Multifunction: 5 timing functions	Reduce stocking requirements
DIP switch adjustable time delay	Field adjustable delay ranging from 0.1s - 63m
0.7A steady, 10A inrush solid-state output	Provides 100 million operations in typical conditions.
Mounting fasteners included	Each unit ships with both surface and DIN rail quick mount adapters
Watchdog circuitry	Self monitoring and self correcting for improved performance

Wiring & Adjustment Diagrams

DELAY-ON-MAKE & RECYCLING

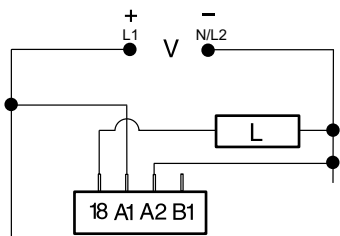

ADJUSTMENTS

DOM	A <input type="checkbox"/>	B <input type="checkbox"/>
SS	A <input type="checkbox"/>	B <input type="checkbox"/>
R	A <input type="checkbox"/>	B <input type="checkbox"/>
DOB	A <input type="checkbox"/>	B <input type="checkbox"/>

DOM = Delay-on-Make
SS = Single Shot/Interval
R = Recycling
DOB = Delay-on-Break

SINGLE SHOT, INTERVAL & DELAY-ON-BREAK

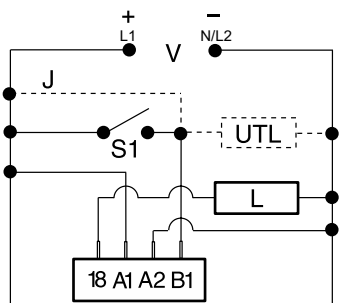

R	M	S	I
0.1-6.3s	X0.1s	C <input type="checkbox"/> E <input type="checkbox"/> D <input type="checkbox"/> F <input type="checkbox"/>	0.1s
1-63s	X1s	C <input type="checkbox"/> E <input type="checkbox"/> D <input type="checkbox"/> F <input type="checkbox"/>	1s
10-630s	X10s	C <input type="checkbox"/> E <input type="checkbox"/> D <input type="checkbox"/> F <input type="checkbox"/>	10s
1-63m	X1m	C <input type="checkbox"/> E <input type="checkbox"/> D <input type="checkbox"/> F <input type="checkbox"/>	1m

R = Range
M = Multiplier
S = Setting
I = Increments of time



Add switches in ON position
TD = 2+8+16=26

Accessories



P1015-13 (AWG 10/12), **P1015-64** (AWG 14/16), **P1015-14** (AWG 18/22) **Female Quick Connect**
These 0.25 in. (6.35 mm) female terminals are constructed with an insulator barrel to provide strain relief.



P0500-178 Surface Mount Adapter
P0500-179 DIN Rail Mount Adapter
For use with the ASxx/DSxx Series timers.

Ordering Information

MODEL	INPUT VOLTAGE	CONNECTION
DSQUA3	24 - 240VAC	Quick Connects
DSQUD3	9 - 110VDC	Quick Connects
DSTUA3	24 - 240VAC	Terminal Blocks
DSTUD3	9 - 110VDC	Terminal Blocks

If you don't find the part you need, call us for a custom product 800-843-8848

12

TIME DELAY RELAYS

V = Voltage
L = Load
J = Wire Required for Interval Operation
S1 = Initiate Switch
UTL = Optional Untimed Load

For dimensional drawing see: Appendix, page 512, Figure 22.

DSQU / DSTU SERIES

Specifications

Time Delay Type	Microcontroller based with ceramic resonator and watchdog circuitry
Adjustment	6 switches adjust the time delay; 2 switches select 1 of 4 multipliers
Range*	x0.1s = 0.1 - 6.3s in 0.1s increments x1s = 1 - 63s in 1s increments x10s = 10 - 630s in 10s increments x1m = 1 - 63m in 1m increments
Repeat Accuracy	±0.1% or ±20ms, whichever is greater
Setting Accuracy	±2% or ±50ms, whichever is greater
Reset Time	≤ 300ms
Initiate Time	Single Shot & Delay-on-Break: ≤ 32ms
Time Delay vs Temp. & Voltage	±2% or ±50ms, whichever is greater
Input Voltage	AC: 24 to 240VAC; -20% - 10% DC: 9 to 110VDC; -0% - 20% @ -25°C 9.4 to 110VDC; -0% - 20% @ -40°C
AC Line Frequency/DC Ripple	50/60Hz / ≤ 10%
Output Type	Solid state
Form	NO
Rating	0.7A steady state, 10A inrush
Voltage Drop	AC ≅ 2.5V @ 0.7A; DC ≅ 1.5V @ 0.7A
Protection	
Surge Circuitry	IEEE C62.41-1991 Level A Encapsulated
Dielectric Breakdown	≥ 2000V RMS terminals to mounting surface
Polarity	DC units are reverse polarity protected
Mechanical	
Mounting	Two base adaptors are available
DIN Rail	Snap on to 32 mm DIN 1 & 35 mm DIN 3 rail
Surface	Two #6 (M3.5 x 0.6) screws or quick mount fasteners
Dimensions	H 76.2 mm (3.0"); W 17.52 mm (0.69"); D 61.2 mm (2.41")
Termination	
DSQU	0.25 in. (6.35 mm) male quick connect terminals
DSTU	0.197 in. (5 mm) push-on terminal blocks for up to #14 AWG (2.5 mm ²) wire
Environmental	
Operating/Storage Temperature	-40° to 60°C / -40° to 85°C
Humidity	95% relative, non-condensing
Weight	≅ 4.2 oz (119 g)

*For CE approved applications, power must be removed from the unit when a switch position is changed.

Mounting Diagrams

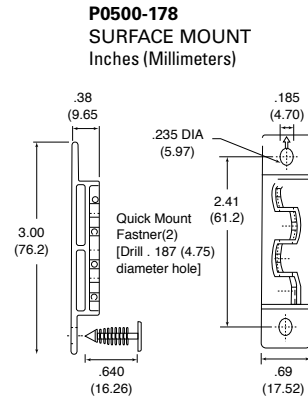

P0500-179
DIN RAIL MOUNT
Inches (Millimeters)

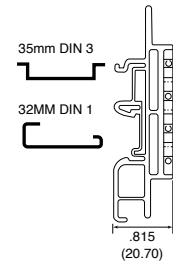

T10 SERIES

Solid-State On-Delay Timer



Description

The T10 Series on-delay timer is a solid-state electronic device that provides accurate and reliable timing for control circuits up to 460VAC. The T10 features a user-selectable time delay from 6 seconds to 10 minutes (0.5 to 12 seconds on the T10S400 model) and SPDT output contacts. When power is applied to the T10, it immediately begins its timing cycle. During this time, the indicator LED alternates between red and green and the output contacts remain inactive. When the timing cycle is complete, the indicator LED turns solid green and the output contacts are activated. The output contacts will remain activated until power is removed from the T10.

The SPDT contact ratings are 480V @ 240VAC on the 115V and 230V models, and 470VA @ 600VAC on the 460V model.

Features & Benefits

- Status LED
- 600V control relay on 460V models

Specifications

Input Characteristics

Frequency 50*/60Hz

Functional Characteristics

Timing Range

T10100, T10200, T10400 6 seconds to 10 minutes
T10S400 0.5 seconds to 12 seconds

Repeat Accuracy

Fixed Condition ±1%

Output Characteristics

Output Contact Rating (SPDT)

Pilot Duty
T10100, T10200 480VA @ 240VAC
T10400, T10S400 470VA @ 600VAC

General Characteristics

Maximum Input Power 5 W

Terminal

Torque 7 in.-lbs.
Wire Size 12-18AWG

Safety Marks

UL UL508 (File #E68520)

Dimensions

H 74.4 mm (2.93"); **W** 133.9 mm (5.27");

D 74.9 mm (2.95")

Weight 0.94 lb. (15.04 oz., 426.38 g)

Mounting Method #8 screws

*Note: 50Hz will increase all delay timers by 20%.

Wiring Diagram

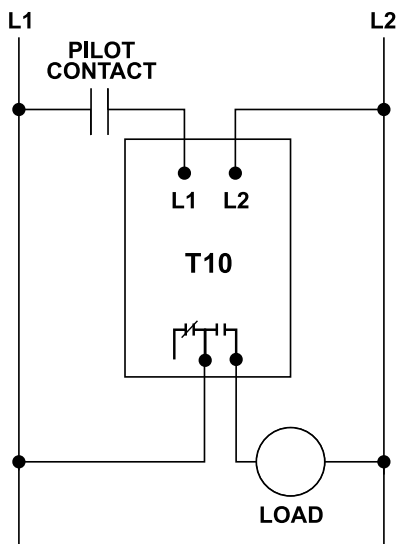

For dimensional drawing see: Appendix page 509, Figure 6.

Ordering Information

MODEL	LINE VOLTAGE	DESCRIPTION
T10120	115VAC	0.1 to 10 minute range, 240 VAC rated output contacts
T10200	230VAC	0.1 to 10 minute range, 240 VAC rated output contacts
T10400	460VAC	0.1 to 10 minute range, 600 VAC rated output contacts
T10S400	460VAC	0.5 to 12 second range, 600 VAC rated output contacts

ERDM SERIES

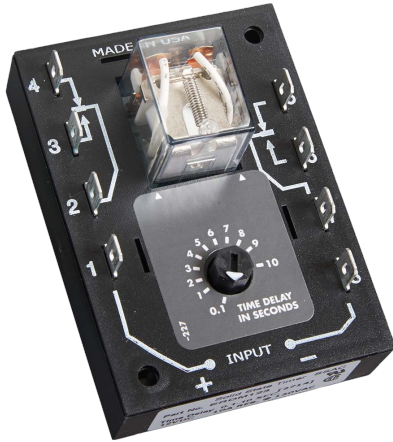

Wiring Diagram

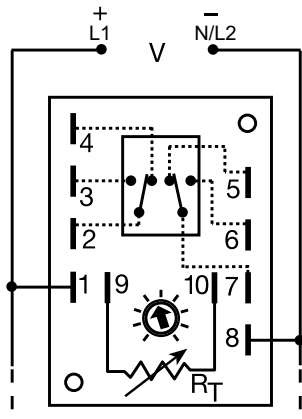

V = Voltage

A knob, or terminals 9 & 10 are only included on adjustable units. Relay contacts are isolated.

R_T is used when external adjustment is ordered.

For dimensional drawing see: Appendix, page 512, Figure 25.

Description

The ERDM Series is a combination of digital electronics and a reliable electromechanical relay. These devices offer a DPDT relay output for relay logic circuits, and isolation of input to output voltages. Cost effective for OEM applications, such as random starting, sequencing ON, switch de-bouncing, anti-short cycling, and other common delay-on-make applications.

Operation (Delay-on-Make)

Upon application of input voltage, the time delay begins. The output is de-energized before and during the time delay. At the end of the time delay, the output energizes and remains energized until input voltage is removed.

Reset: Removing input voltage resets the time delay and output.

Features & Benefits

FEATURES	BENEFITS
Digital integrated circuitry with electromechanical relay	Repeat Accuracy +/- 0.5%
Isolated 10A, DPDT output contacts	Allows control of loads for AC or DC voltages
Encapsulated	Protects against shock, vibration, and humidity

Accessories



P1004-16, P1004-16-XVersa-Pot
Panel mountable, industrial potentiometer recommended for remote time delay adjustment.



P1015-64 (AWG 14/16) Female Quick Connect
These 0.25 in. (6.35 mm) female terminals are constructed with an insulator barrel to provide strain relief.



P1015-18 Quick Connect to Screw Adapter
Screw adapter terminal designed for use with all modules with 0.25 in. (6.35 mm) male quick connect terminals.

Ordering Information

MODEL	INPUT VOLTAGE	ADJUSTMENT	TIME DELAY	MODEL	INPUT VOLTAGE	ADJUSTMENT	TIME DELAY
ERDM123	12VDC	Onboard knob	0.1 - 10s	ERDM422	120VAC	Onboard knob	0.1 - 5s
ERDM126	12VDC	Onboard knob	0.6 - 60s	ERDM423	120VAC	Onboard knob	0.1 - 10s
ERDM128	12VDC	Onboard knob	0.1 - 10m	ERDM425	120VAC	Onboard knob	0.3 - 30s
ERDM222	24VAC	Onboard knob	0.1 - 5s	ERDM427	120VAC	Onboard knob	0.1 - 5m
ERDM4130S	120VAC	Fixed	30s	ERDM429	120VAC	Onboard knob	0.2 - 15m
ERDM4210	120VAC	Onboard knob	1 - 100m				

If you don't find the part you need, call us for a custom product 800-843-8848

ERDM SERIES

Specifications

Time Delay

Type Digital integrated circuitry
Range 0.1s - 500m in 11 adjustable ranges or
0.1s - 1000m fixed

Adjustment Fixed, onboard or external adjust
Repeat Accuracy ±0.5%

Tolerance ≤ ±10%
(Factory Calibration)

Recycle Time ≤ 150ms

Time Delay vs Temp. & Voltage ≤ ±2%

Input

Voltage 12, 24, or 120VDC; 24, 120, or 230VAC

Tolerance -15% - 20%

12VDC & 24VDC/AC -20% - 10%

120VAC/DC & 230VAC

AC Line Frequency 50/60 Hz

Output

Type Isolated relay contacts

Form DPDT
Rating 10A resistive @ 120/240VAC & 28VDC;
1/3 hp @ 120/240VAC

Life Mechanical - 1 x 10⁷; Full Load - 1 x 10⁶

Protection

Isolation Voltage ≥1500V RMS input to output

Insulation Resistance ≥100 MΩ

Polarity DC units are reverse polarity protected

Mechanical

Mounting Surface mount with two #6
(M3.5 x 0.6) screws

Dimensions **H** 88.9 mm (3.5"); **W** 63.5 mm (2.5");
D 43.2 mm (1.7")

Termination 0.25 in. (6.35 mm) male quick connect terminals

Environmental

Operating/Storage Temperature -40° to 65°C / -40° to 85°C

Weight ≈ 5.7 oz (162 g)

Selection Guides

R _T Selection Chart						
Desired Time Delay*						R _T
Seconds						
1	2	3	4	5	6	Megohm
0.1	0.1	0.1	0.2	0.3	0.6	0.0
0.19	0.6	1	1.7	3	6	0.1
0.28	1.1	2	3.2	6	12	0.2
0.37	1.6	3	4.7	9	18	0.3
0.46	2.1	4	6.2	12	24	0.4
0.55	2.6	5	7.7	15	30	0.5
0.64	3.0	6	9.2	18	36	0.6
0.73	3.5	7	10.7	21	42	0.7
0.82	4.0	8	12.2	24	48	0.8
0.91	4.5	9	13.7	27	54	0.9
1.0	5.0	10	15	30	60	1.0

* When selecting an external R_T add at least 20% for tolerance of unit and the R_T.

R _T Selection Chart					
Desired Time Delay*					R _T
Minutes					
7	8	9	10	11	Megohm
0.1	0.1	0.2	1	10	0.0
0.6	1	1.7	10	50	0.1
1.1	2	3.2	20	100	0.2
1.6	3	4.7	30	150	0.3
2.1	4	6.2	40	200	0.4
2.6	5	7.7	50	250	0.5
3.0	6	9.2	60	300	0.6
3.5	7	10.7	70	350	0.7
4.0	8	12.2	80	400	0.8
4.5	9	13.7	90	450	0.9
5.0	10	15	100	500	1.0

* When selecting an external R_T add at least 20% for tolerance of unit and the R_T.

Function Diagram

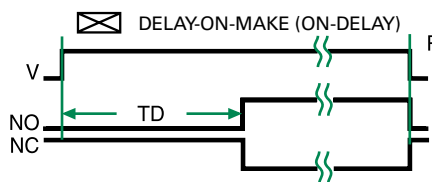

V = Voltage
NO = Normally Open Contact
NC = Normally Closed Contact
TD = Time Delay
R = Reset
—||— = Undefined Time

HRDM SERIES

Delay-on-Make Timer



Wiring Diagram

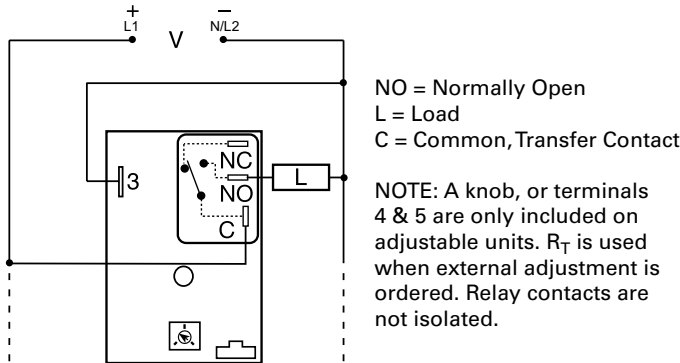

For dimensional drawing see: Appendix, page 512, Figure 17.

Ordering Information

MODEL	INPUT VOLTAGE	ADJUSTMENT	TIME DELAY
HRDM120	12VDC	Onboard	0.1 - 10s
HRDM3112S	24VDC	Fixed	12s
HRDM413M	120VAC	Fixed	3m
HRDM415M	120VAC	Fixed	5m

If you don't find the part you need, call us for a custom product 800-843-8848

Description

The HRDM Series combines an electromechanical relay output with microcontroller timing circuitry. It offers 12 to 230V operation in five ranges and factory fixed, onboard, or external adjustable time delays with a repeat accuracy of $\pm 0.5\%$. The output contact rating allows for direct operation of heavy loads, such as compressors, pumps, blower motors, heaters, etc. This series is ideal for OEM applications where cost is a factor.

Operation (Delay-on-Make)

Upon application of input voltage, the time delay begins. The output is de-energized before and during the time delay. At the end of the time delay, the output relay energizes and remains energized until input voltage is removed.

Reset: Removing input voltage resets the time delay and output.

Features & Benefits

FEATURES	BENEFITS
Microcontroller based	Repeat Accuracy $\pm 0.5\%$
Compact, low cost design	Allows flexibility for OEM applications
Isolated, 30A, SPDT, NO output contacts	Allows direct operation of heavy loads: compressors, pumps, blower motors, heaters.
Encapsulated	Protects against shock, vibration, and humidity

Accessories



P1004-95, P1004-95-X Versa-Pot
Panel mountable, industrial potentiometer recommended for remote time delay adjustment.



P1023-6 Mounting bracket
The 90° orientation of mounting slots makes installation/removal of modules quick and easy.



P0700-7 Versa-Knob
Designed for 0.25 in. (6.35 mm) shaft of Versa-Pot. Semi-gloss industrial black finish.



P1015-13 (AWG 10/12), P1015-64 (AWG 14/16) Female Quick Connect
These 0.25 in. (6.35 mm) female terminals are constructed with an insulator barrel to provide strain relief.



P1015-18 Quick Connect to Screw Adapter
Screw adapter terminal designed for use with all modules with 0.25 in. (6.35 mm) male quick connect terminals.



C103PM (AL) DIN Rail
35 mm aluminum DIN rail available in a 36 in. (91.4 cm) length.



P1023-20 DIN Rail Adapter
Allows module to be mounted on a 35 mm DIN type rail with two #10 screws.

HRDM SERIES

External Resistance vs. Time Delay

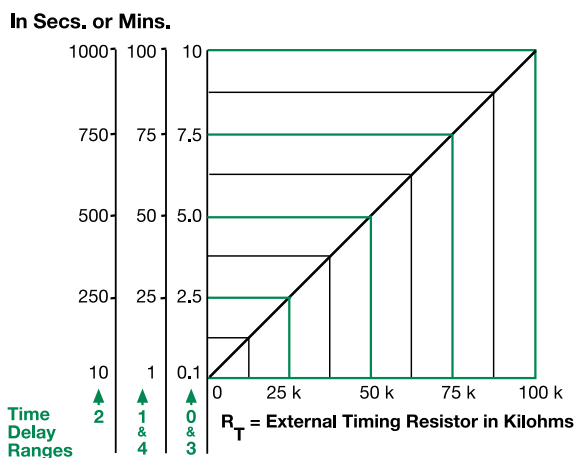

This chart applies to externally adjustable part numbers.
The time delay is adjustable over the time delay range selected by varying the resistance across the R_T terminals; as the resistance increases the time delay increases.
When selecting an external R_T, add the tolerances of the timer and the R_T for the full time range adjustment.
Examples: 1 to 50 S adjustable time delay, select time delay range 1 and a 50 K ohm R_T. For 1 to 100 S use a 100 K ohm R_T.

Function Diagram

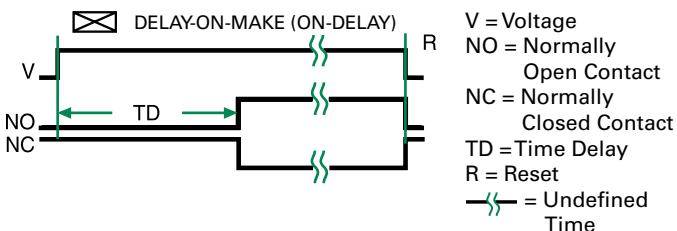

Specifications

Time Delay

Type Microcontroller circuitry
Range 0.1s - 100m in 5 adjustable ranges or fixed
Repeat Accuracy ±0.5% or 20 ms, whichever is greater
Tolerance (Factory Calibration) ±1%, ±5%
Reset Time ≤ 150ms
Time Delay vs Temp. & Voltage ±2%

Input

Voltage 12 or 24VDC; 24, 120, or 230VAC
Tolerance
12VDC & 24VDC -15% - 20%
24 to 230VAC -20% - 10%
AC Line Frequency 50/60 Hz
Power Consumption AC ≤ 4VA; DC ≤ 2W

Output

Type Electromechanical relay
Form Non-isolated, SPDT
Ratings

	SPDT-NO	SPDT-NC
General Purpose 125/240VAC	30A	15A
Resistive 125/240VAC	30A	15A
28VDC	20A	10A
Motor Load 125VAC	1 hp*	1/4 hp**
240VAC	2 hp**	1 hp**

Life

Mechanical - 1 x 10⁶;
Electrical - 1 x 10⁵, *3 x 10⁴, **6,000

Protection

Surge IEEE C62.41-1991 Level A
Circuitry Encapsulated
Dielectric Breakdown ≥ 2000V RMS terminals to mounting surface
Insulation Resistance ≥ 100 MΩ
Polarity DC units are reverse polarity protected

Mechanical

Mounting Surface mount with one #10 (M5 x 0.8) screw
Dimensions 3 x 2 x 1.5 in. (76.7 x 51.3 x 38.1mm)
Termination 0.25 in. (6.35 mm) male quick connect terminals

Environmental

Operating/Storage Temperature -40° to 60°C / -40° to 85°C
Humidity 95% relative, non-condensing
Weight ≈ 3.9 oz (111 g)

KRDM SERIES



Description

The KRDM Series is a compact time delay relay measuring only 2 in. (50.8 mm) square. Its solid-state timing circuit provides excellent repeat accuracy and stability. Encapsulation protects against shock, vibration, and humidity. The KRDM Series is a cost effective approach for OEM applications that require small size, isolation, reliability, and long life.

Operation (Delay-on-Make)

Upon application of input voltage, the time delay begins. The output is de-energized before and during the time delay. At the end of the time delay, the output relay energizes and remains energized until input voltage is removed.

Reset: Removing input voltage resets the time delay and output.

Features & Benefits

FEATURES	BENEFITS
Microcontroller based	Repeat Accuracy +/- 0.5%
Compact, low cost design	Allows flexibility for OEM applications
Isolated, 10A, SPDT output contacts	Allows control of loads for AC or DC voltages
Encapsulated	Protects against shock, vibration, and humidity

Wiring Diagram

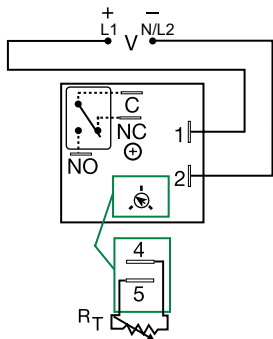

V = Voltage
C = Common, Transfer Contact
NO = Normally Open
NC = Normally Closed

A knob is supplied for adjustable units, or R_T terminals 4 & 5 for external adjust. See external adjustment vs time delay chart. Relay contacts are isolated.

For dimensional drawing see: Appendix, page 512, Figure 16.

Accessories



P1004-95, P1004-95-X Versa-Pot

Panel mountable, industrial potentiometer recommended for remote time delay adjustment.



P1023-6 Mounting bracket

The 90° orientation of mounting slots makes installation/removal of modules quick and easy.



P0700-7 Versa-Knob

Designed for 0.25 in (6.35 mm) shaft of Versa-Pot. Semi-gloss industrial black finish.

Ordering Information

MODEL	INPUT VOLTAGE	ADJUSTMENT	TIME DELAY	MODEL	INPUT VOLTAGE	ADJUSTMENT	TIME DELAY
KRDM1110S	12VDC	Fixed	10s	KRDM4110M	120VAC	Fixed	10m
KRDM1130S	12VDC	Fixed	30s	KRDM4110S	120VAC	Fixed	10s
KRDM120	12VDC	Onboard knob	0.1 - 10s	KRDM4145S	120VAC	Fixed	45s
KRDM121	12VDC	Onboard knob	1 - 100s	KRDM420	120VAC	Onboard knob	0.1 - 10s
KRDM2110M	24VAC/DC	Fixed	10m	KRDM421	120VAC	Onboard knob	1 - 100s
KRDM215M	24VAC/DC	Fixed	5m	KRDM424	120VAC	Onboard knob	1 - 100m
KRDM220	24VAC/DC	Onboard knob	0.1 - 10s	KRDM430	120VAC	External	0.1 - 10s
KRDM221	24VAC/DC	Onboard knob	1 - 100s	KRDM433	120VAC	External	0.1 - 10m
KRDM223	24VAC/DC	Onboard knob	0.1 - 10m	KRDM6115M	230VAC	Fixed	15m
KRDM310.2S	24VDC	Fixed	0.2s				

If you don't find the part you need, call us for a custom product 800-843-8848

KRDM SERIES

Accessories



P1015-13 (AWG 10/12), **P1015-64** (AWG 14/16)
Female Quick Connect
These 0.25 in. (6.35 mm) female terminals are constructed with an insulator barrel to provide strain relief.



P1015-18 Quick Connect to Screw Adapter
Screw adapter terminal designed for use with all modules with 0.25 in. (6.35 mm) male quick connect terminals.



C103PM (AL) DIN Rail
35 mm aluminum DIN rail available in a 36 in. (91.4 cm) length.



P1023-20 DIN Rail Adapter
Allows module to be mounted on a 35 mm DIN type rail with two #10 screws.

External Resistance vs. Time Delay

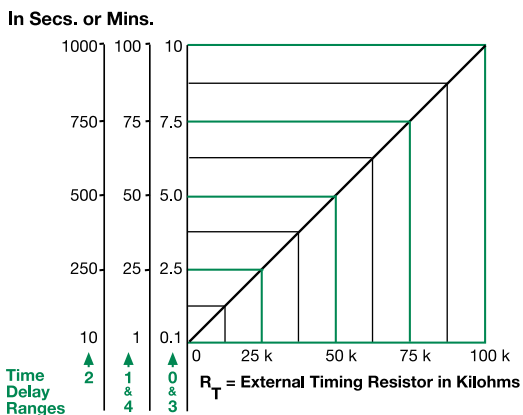

This chart applies to externally adjustable part numbers. The time delay is adjustable over the time delay range selected by varying the resistance across the R_T terminals; as the resistance increases the time delay increases. When selecting an external R_T , add the tolerances of the timer and the R_T for the full time range adjustment.
Examples: 1 to 50 S adjustable time delay, select time delay range 1 and a 50 K ohm R_T . For 1 to 100 S use a 100 K ohm R_T .

Output Current / Ambient Temperature

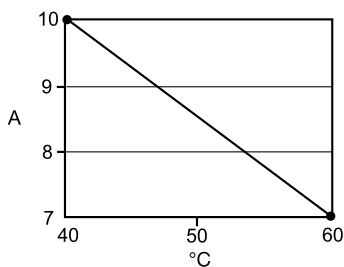

Specifications

Time Delay Range	0.1s - 100ms in 5 adjustable ranges or fixed
Repeat Accuracy	±0.5% or 20ms, whichever is greater
Tolerance (Factory Calibration)	≤ ±5%
Recycle Time	≤ 150ms
Time Delay vs Temp. & Voltage	≤ ±5%
Input Voltage	12, 24 or 110VDC; 24, 120 or 230VAC
Tolerance 12VDC & 24VAC/DC	-15% - 20%
110VDC 120 & 230VAC	-20% - 10%
AC Line Frequency/DC Ripple	50/60 Hz / ≤ 10%
Power Consumption	AC ≤ 2VA; DC ≤ 2W
Output Type	Isolated relay contacts
Form	SPDT
Rating (at 40°C)	10A resistive @ 125VAC; 5A resistive @ 230VAC & 28VDC; 1/4 hp @ 125VAC
Max. Switching Voltage	250VAC
Life (Operations)	Mechanical - 1 x 10 ⁷ ; Electrical - 1 x 10 ⁵
Protection	Encapsulated
Circuitry	≥ 1500V RMS input to output
Isolation Voltage	≥ 100 MΩ
Insulation Resistance	DC units are reverse polarity protected
Polarity	
Mechanical	
Mounting	Surface mount with one #10 (M5 x 0.8) screw
Dimensions	H 50.8 mm (2.0"); W 50.8 mm (2.0"); D 30.7 mm (1.21")
Termination	0.25 in. (6.35 mm) male quick connect terminals
Environmental	
Operating/Storage Temperature	-20° to 60°C / -40° to 85°C
Humidity	95% relative, non-condensing
Weight	≈ 2.6 oz (74 g)

Function Diagram

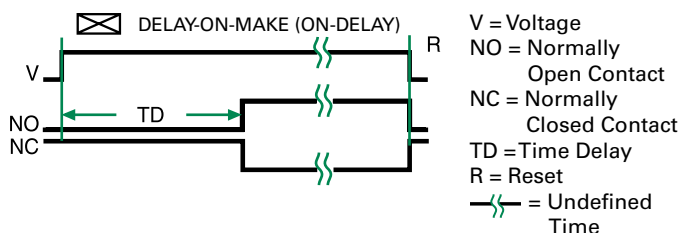

KRPS SERIES



Wiring Diagram

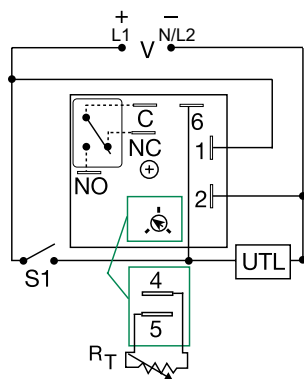

V = Voltage
C = Common, Transfer Contact
NC = Normally Closed
NO = Normally Open
S1 = Initiate Switch
UTL = Untimed Load

A knob is supplied for adjustable units, or R_T terminals 4 & 5 for external adjust. See external adjustment vs. time delay chart. The untimed load is optional. S1 is not used for some functions.

For dimensional drawing see: Appendix, page 512, Figure 16.

Ordering Information

MODEL	INPUT VOLTAGE	ADJUST.	TIME DELAY	FUNCTION
KRPS4160MM	120VAC	Fixed	60m	Delay-on-Make
KRPS913MB	230VAC	Fixed	3m	Delay-on-Break
KRPSA10.1SFT	24 - 240VAC/DC	Fixed	0.1s	Alternating
KRPSA21RE	24 - 240VAC/DC	Onboard	0.1 - 10s	Recycling, On Time First
KRPSA22B	24 - 240VAC/DC	Onboard	1 - 100s	Delay-on-Break
KRPSA24M	24 - 240VAC/DC	Onboard	0.1 - 10m	Delay-on-Make
KRPSD10.1SF	12 to 48VDC	Fixed	0.1s	Leading Edge Flip-Flop
KRPSD21B	12 to 48VDC	Onboard	0.1 - 10s	Delay-on-Break
KRPSD21M	12 to 48VDC	Onboard	0.1 - 10s	Delay-on-Make
KRPSD22M	12 to 48VDC	Onboard	1 - 100s	Delay-on-Make
KRPSD22S	12 to 48VDC	Onboard	1 - 100s	Single Shot
KRPSD25S	12 to 48VDC	Onboard	1 - 100m	Single Shot

If you don't find the part you need, call us for a custom product 800-843-8848

Description

The KRPS Series is a factory programmed time delay relay available with 1 of 15 functions and measures only 2 inches square. The KRPS offers a wide range of fixed, onboard, or externally adjustable time delays. The output relay contacts offer a full 10A rating with complete isolation. Its microcontroller timing circuit provides excellent repeat accuracy and stability. Encapsulation protects against shock, vibration, and humidity. The KRPS Series is a cost effective approach for OEM applications that require small size, isolation, accuracy, and long life. Special time ranges and functions are available.

Features & Benefits

FEATURES	BENEFITS
Microcontroller based	Repeat Accuracy +/- 0.5%
Compact design	Allows flexibility for OEM applications
Isolated, SPDT, 10A output	Allows control of loads for AC or DC voltages
Encapsulated	Encapsulated to protect against shock, vibration, and humidity

Accessories



P1004-95, P1004-95-X Versa-Pot

Panel mountable, industrial potentiometer recommended for remote time delay adjustment.



P0700-7 Versa-Knob

Designed for 0.25 in. (6.35 mm) shaft of Versa-Pot. Semi-gloss industrial black finish.



P1015-64 (AWG 14/16)

Female Quick Connect

These 0.25 in. (6.35 mm) female terminals are constructed with an insulator barrel to provide strain relief.



P1015-18 Quick Connect to Screw Adapter

Screw adapter terminal designed for use with all modules with 0.25 in. (6.35 mm) male quick connect terminals.



C103PM (AL) DIN Rail

35 mm aluminum DIN rail available in a 36 in. (91.4 cm) length.



P1023-20 DIN Rail Adapter

Allows module to be mounted on a 35 mm DIN type rail with two #10 screws.

KRPS SERIES

Specifications

Time Delay

Type	Microcontroller circuitry
Range	0.1s - 1000h in 9 adjustable ranges or fixed
Repeat Accuracy	±0.5% or 20ms, whichever is greater
Tolerance	
(Factory Calibration)	≤ ±2%
Reset Time	≤ 150ms
Initiate Time	≤ 40ms; ≤ 750 operations per minute
Time Delay vs Temp. & Voltage	≤ ±2%

Input

Voltage	12 to 48VDC; 24 to 240VAC/DC
Tolerance	
12 to 48VDC	-15% - 20%
24 to 240VAC/DC	-20% - 10%
AC Line Frequency/DC Ripple	50/60Hz / ≤ 10%
Power Consumption	AC ≤ 2VA; DC ≤ 2W

Output

Type	Isolated relay contacts
Form	SPDT
Rating (at 40°C)	10A resistive @ 125VAC 5A resistive @ 230VAC & 28VDC 1/4 hp @ 125VAC
Max. Switching Voltage	250VAC
Life (Operations)	Mechanical - 1 x 10 ⁷ ; Electrical - 1 x 10 ⁵

Protection

Circuitry	Encapsulated
Isolation Voltage	≥ 1500V RMS input to output
Insulation Resistance	≥ 100 MΩ
Polarity	DC units are reverse polarity protected

Mechanical

Mounting	Surface mt. with one #10 (M5 x 0.8) screw
Dimensions	H 50.8 mm (2.0"); W 50.8 mm (2.0"); D 30.7 mm (1.21") 0.25 in. (6.35 mm) male quick connects

Termination

Environmental

Operating/Storage Temperature	-40° to 60°C / -40° to 85°C
Humidity	95% relative, non-condensing
Weight	≈ 2.6 oz (74 g)

Output Current/Ambient Temperature

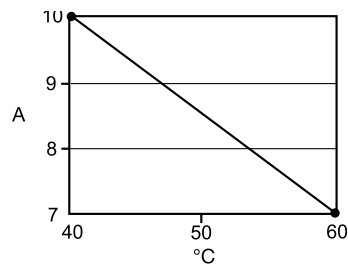

Timer Functions

Operation (Delay-on-Make)

Upon application of the input voltage, the time delay begins. The output relay is de-energized before and during the time delay. At the end of the time delay, the output energizes and remains energized until input voltage is removed.

Reset: Removing input voltage resets the time delay and output.

Operation (Delay-on-Break)

Input voltage must be applied before and during timing. Upon closure of the initiate switch, the output relay energizes. The time delay begins when the initiate switch is opened. The output remains energized during timing. At the end of the time delay, the output de-energizes. The output will energize if the initiate switch is closed when input voltage is applied.

Reset: Re-closing the initiate switch during timing resets the time delay. Removing input voltage resets the time delay and output.

Operation (Recycling)

Upon application of input voltage, the output relay energizes and the ON time begins. At the end of the ON time, the output de-energizes and the OFF time begins. At the end of the OFF time, the output energizes and the cycle repeats as long as input voltage is applied.

Reset: Removing input voltage resets the output and time delays, and returns the sequence to the first delay.

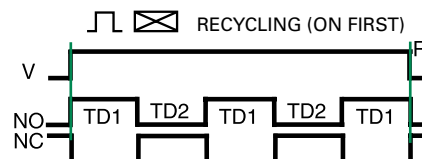
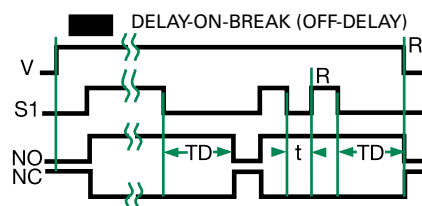
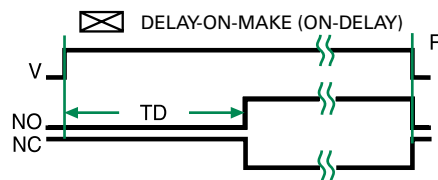

KRPS SERIES

Operation (Alternating)

Input voltage must be applied at all times for proper operation. The operation begins with the output relay de-energized. Closing S1 enables the next alternating operation. When S1 opens (trailing edge triggered), the time delay begins. At the end of the time delay, the output energizes and remains energized until S1 is (re-closed and) re-opened. Then the output relay de-energizes and remains until S1 opens again. Each time S1 opens the time delay occurs and the output transfers.

Reset: Removing input voltage resets the output and the time delay.

Operation (Single Shot)

Input voltage must be applied before and during timing. Upon momentary or maintained closure of the initiate switch, the output (relay or solid state) energizes and the time delay begins. At the end of the delay, the output de-energizes. Opening or re-closing the initiate switch during timing has no effect on the time delay. Note (for most single shot timers): If the initiate switch is closed when input voltage is applied, the output energizes and the time delay begins.

Reset: Reset occurs when the time delay is complete and the initiate switch is opened. Removing input voltage resets the time delay and output.

Operation (Retriggerable Single Shot, Motion Detector)

Input voltage must be applied prior to and during timing. The output relay is de-energized. When the initiate switch S1 closes momentarily or maintained, the output energizes and the time delay begins. Upon completion of the delay, the output de-energizes.

Reset: Re-closing S1 resets the time delay and restarts timing. Removing input voltage resets the time delay and output.

Operation (Trailing Edge Single Shot, Impulse-OFF)

Input voltage must be applied before and during timing. When the initiate switch S1 opens, the output relay energizes. At the end of the time delay, the output de-energizes. Re-closing and opening S1 during timing has no effect on the time delay. The output will not energize if S1 is open when input voltage is applied.

Reset: Reset occurs when the time delay is complete and S1 is closed. Removing input voltage resets the time delay and output.

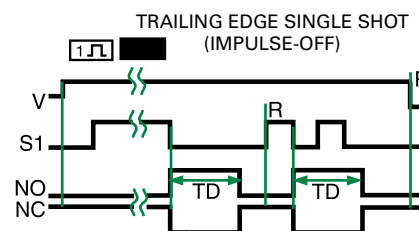
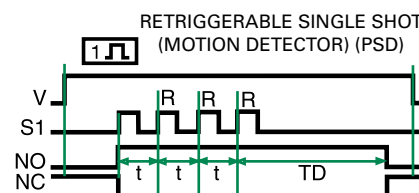
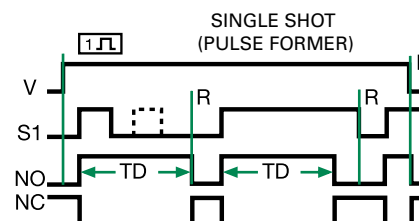
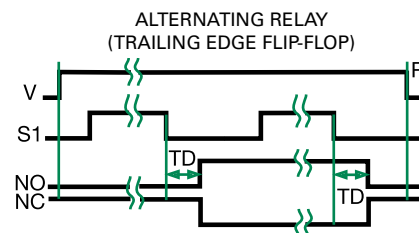

LEGEND

V = Voltage
R = Reset
T1 = ON Time

T2 = OFF Time
S1 = Initiate Switch
NO = Normally Open Contact

NC = Normally Closed Contact
t = Incomplete Time Delay
TD, TD1, TD2 = Time Delay

C = Count
P = Pulse Duration
— = Undefined Time

KSD1 SERIES

Delay-on-Make Timer



Description

The KSD1 Series features two-terminal, series-connection with the load. The KSD1 Series is an ideal choice for delay-on-make timing applications. This series is designed for general purpose commercial and industrial applications where a small, cost effective, reliable solid-state timer is required. The factory calibration for fixed time delays is within 5% of the target time delay. The repeat accuracy, under stable conditions, is 0.5% of the selected time delay. This series is designed for popular AC and DC voltages. Time delays of 0.1 seconds to 1000 minutes are available in 6 ranges. The output is rated 1A steady and 10A inrush. The modules are totally solid state and encapsulated to protect the electronic circuitry.

Operation (Delay-on-Make)

Upon application of input voltage, the time delay begins. The output is de-energized before and during the time delay. At the end of the time delay, the output energizes and remains energized until input voltage is removed.

Reset: Removing input voltage resets the time delay and output.

Wiring Diagram

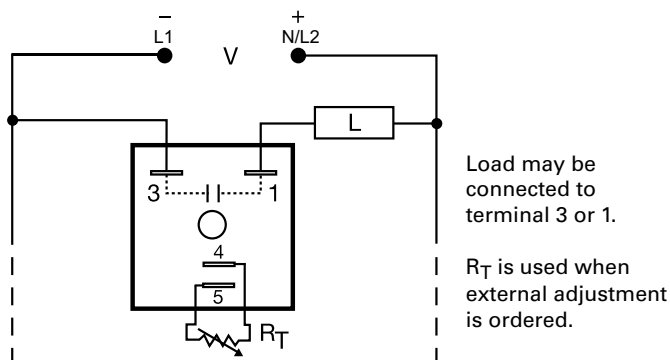

For dimensional drawing see: Appendix, page 512, Figure 16.

Features & Benefits

FEATURES	BENEFITS
Microcontroller based	Repeat Accuracy +/- 0.5%, +/- 5% time delay accuracy
Compact, low cost design	Allows flexibility for OEM applications
1A Steady solid-state output, 10A inrush	Provides 100 million operations in typical conditions.
Totally solid state and encapsulated	No moving parts to arc and wear out over time and encapsulated to protect against shock, vibration, and humidity

Accessories



P1004-95, P1004-95-X Versa-Pot
Panel mountable, industrial potentiometer recommended for remote time delay adjustment.



P1023-6 Mounting bracket
The 90° orientation of mounting slots makes installation/removal of modules quick and easy.



P0700-7 Versa-Knob
Designed for 0.25 in (6.35 mm) shaft of Versa-Pot. Semi-gloss industrial black finish.



P1015-64 (AWG 14/16) Female Quick Connect
These 0.25 in. (6.35 mm) female terminals are constructed with an insulator barrel to provide strain relief.

Ordering Information

MODEL	INPUT VOLTAGE	ADJUSTMENT	TIME DELAY
KSD11120S	12VDC	Fixed	20s
KSD1123	12VDC	External	0.1 - 10m
KSD1230	24VAC	Onboard	0.1 - 10s
KSD1320	24VDC	External	0.1 - 10s
KSD1412S	120VAC	Fixed	2s
KSD14130S	120VAC	Fixed	30s
KSD1420	120VAC	External	0.1 - 10s
KSD16130S	230VAC	Fixed	30s

If you don't find the part you need, call us for a custom product 800-843-8848

KSD1 SERIES

Accessories



C103PM (AL) DIN Rail
35 mm aluminum DIN rail available in a 36 in. (91.4 cm) length.



P1023-20 DIN Rail Adapter
Allows module to be mounted on a 35 mm DIN type rail with two #10 screws.

External Resistance vs. Time Delay

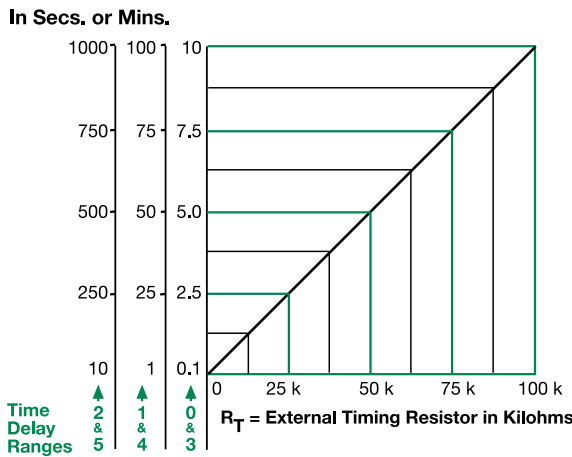

This chart applies to externally adjustable part numbers.
The time delay is adjustable over the time delay range selected by varying the resistance across the R_T terminals; as the resistance increases the time delay increases.

When selecting an external R_T , add the tolerances of the timer and the R_T for the full time range adjustment.

Examples: 1 to 50 S adjustable time delay, select time delay range 1 and a 50 K ohm R_T . For 1 to 100 S use a 100 K ohm R_T .

Function Diagram

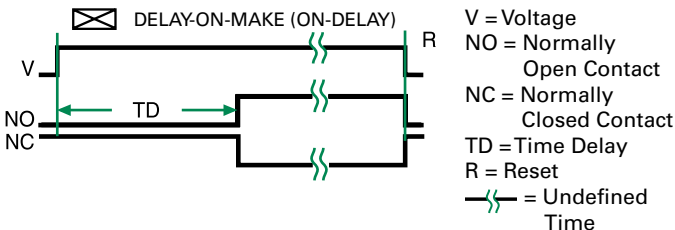

Specifications

Time Delay Range	0.1s - 1000ms in 6 adjustable ranges or fixed
Repeat Accuracy	±0.5% or 20ms, whichever is greater
Tolerance (Factory Calibration)	≤ ±5%
Recycle Time	≤ 150ms
Time Delay vs. Temperature & Voltage	≤ ±10%
Input Voltage	24, 120, or 230VAC; 12 or 24VDC
Tolerance	±20%
AC Line Frequency	50/60 Hz
Output Type	Solid state
Form	NO, open during timing
Maximum Load Current	1A steady state, 10A inrush at 60°C
Minimum Holding Current	≤ 40mA
OFF State Leakage Current	≅ 7mA @ 230VAC
Voltage Drop	≅ 2.5V @ 1A
Protection Circuitry	Encapsulated
Dielectric Breakdown	≥ 2000V RMS terminals to mounting surface
Insulation Resistance	≥ 100 MΩ
Polarity	DC units are reverse polarity protected
Mechanical Mounting	Surface mount with one #10 (M5 x 0.8) screw
Dimensions	H 50.8 mm (2"); W 50.8 mm (2"); D 30.7 mm (1.21")
Termination	0.25 in. (6.35 mm) male quick connect terminals
Environmental Operating/Storage Temperature	-40° to 60°C / -40° to 85°C
Humidity	95% relative, non-condensing
Weight	≅ 2.4 oz (68 g)

KSDU SERIES



Description

The KSDU Series are encapsulated solid-state, delay-on-make timers that combine digital timing circuitry with universal voltage operation. The KSDU Series is factory fixed from 0.1s to 10,230s and does not include the DIP switch. These series are excellent choices for process control systems and OEM equipment.

Operation (Delay-on-Make)

Upon application of input voltage, the time delay begins. The output is de-energized before and during the time delay. At the end of the time delay, the output energizes and remains energized until input voltage is removed.

Reset: Removing input voltage resets the time delay and output.

Features & Benefits

FEATURES	BENEFITS
Universal Voltage	24 to 240VAC/DC in 2 ranges
Digital Integrated Circuitry	Repeat accuracy +/- 5%
1A Steady, 10A inrush solid-state output	Provides 100 million operations in typical conditions.
Totally solid state and encapsulated	No moving parts to arc and wear out over time and encapsulated to protect against shock, vibration, and humidity
2 terminal design	Provides series connection for easy installation

Wiring Diagram

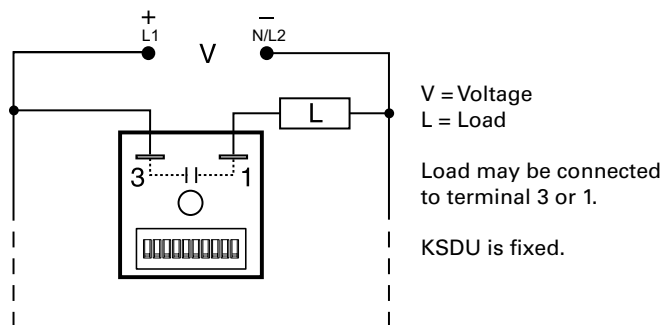

For dimensional drawing see: Appendix, page 512, Figure 16.

Accessories



P1023-6 Mounting bracket

The 90° orientation of mounting slots makes installation/removal of modules quick and easy.



P1015-64 (AWG 14/16) Female Quick Connect

These 0.25 in. (6.35 mm) female terminals are constructed with an insulator barrel to provide strain relief.



P1015-18 Quick Connect to Screw Adapter

Screw adapter terminal designed for use with all modules with 0.25 in. (6.35 mm) male quick connect terminals.



C103PM (AL) DIN Rail

35 mm aluminum DIN rail available in a 36 in. (91.4 cm) length.



P1023-20 DIN Rail Adapter

Allows module to be mounted on a 35 mm DIN type rail with two #10 screws.

Ordering Information

MODEL	INPUT VOLTAGE	ADJUSTMENT	TIME DELAY
KSDU8120	24 to 120VAC/DC	Fixed	20s
KSDU811200	24 to 120VAC/DC	Fixed	1200s

If you don't find the part you need, call us for a custom product 800-843-8848

12

TIME DELAY RELAYS

KSDU SERIES

Specifications

Time Delay

Type	Digital integrated circuitry
Range*	Fixed from 0.1s - 10230s
Fixed	
Repeat Accuracy	±0.5% or 20ms, whichever is greater
Tolerance	
(Factory Calibration)	±10%
Recycle Time	≤150ms
Time Delay vs Temp. & Voltage	±5%

Input

Voltage	24 to 120VAC/DC; 100 to 240VAC/DC
AC Line Frequency	50/60 Hz
Tolerance	±20%

Output

Type	Solid state
Form	NO, open during timing
Maximum Load Current	1A steady state, 10A inrush at 60°C
Minimum Holding Current	40mA
Voltage Drop	≈ 2.5V @ 1A

Protection

Circuitry	Encapsulated
Dielectric Breakdown	≥ 2000V RMS terminals to mounting surface
Insulation Resistance	≥100 MΩ

Mechanical

Mounting	Surface mount with one #10 (M5 x 0.8) screw
Dimensions	H 50.8 mm (2.0"); W 50.8 mm (2.0"); D 30.7 mm (1.21")
Termination	0.25 in. (6.35 mm) male quick connect terminals

Environmental

Operating/Storage Temperature	-40° to 60°C / -40° to 85°C
Humidity	95% relative, non-condensing
Weight	≈ 2.4 oz (68 g)

* For CE approved applications, power must be removed from the unit when a switch position is changed.

Function Diagram

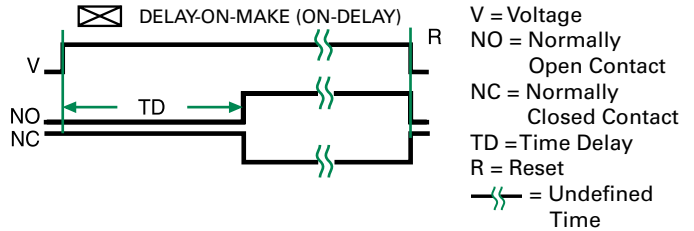

KSPS SERIES

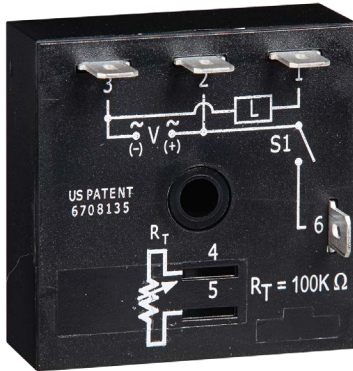

Description

The KSPS Series is a factory programmed module available in any 1 of 14 standard functions. The KSPS Series offers a single, fixed, externally or onboard adjustable time delay. The 1A steady, 10A inrush rated solid-state output provides 100 million operations typical. Its microcontroller timing circuit provides excellent repeat accuracy and stability. Encapsulation protects against shock, vibration, and humidity. The KSPS Series is a cost effective approach for OEM applications that require small size and solid state reliability.

Features & Benefits

FEATURES	BENEFITS
Microcontroller based	Repeat Accuracy + / - 0.5%
Compact design	Allows flexibility for OEM applications
1A steady, 10A inrush solid-state output	Provides 100 million operations in typical conditions.
Totally solid state and encapsulated	No moving parts to arc and wear out over time and encapsulated to protect against shock, vibration, and humidity

Wiring Diagram

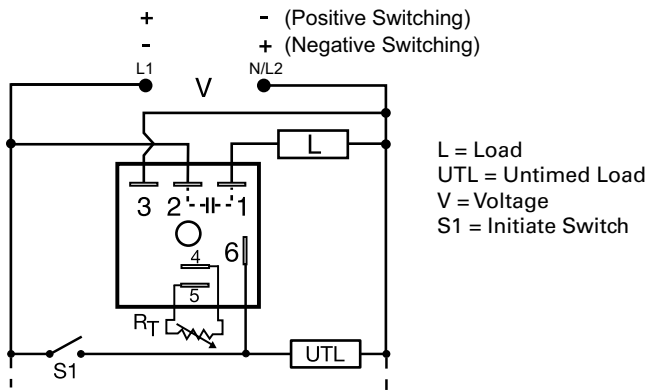

For dimensional drawing see: Appendix, page 512, Figure 16.

Accessories



P1004-95, P1004-95-X Versa-Pot
Panel mountable, industrial potentiometer recommended for remote time delay adjustment.



P0700-7 Versa-Knob
Designed for 0.25 in. (6.35 mm) shaft of Versa-Pot. Semi-gloss industrial black finish.



P1015-64 (AWG 14/16) Female Quick Connect
These 0.25 in. (6.35 mm) female terminals are constructed with an insulator barrel to provide strain relief.



P1015-18 Quick Connect to Screw Adapter
Screw adapter terminal designed for use with all modules with 0.25 in. (6.35 mm) male quick connect terminals.

Ordering Information

MODEL	INPUT VOLTAGE	ADJUSTMENT	TIME DELAY	FUNCTION
KSPS2180SB	24VAC	Fixed	80s	Delay-on-Break
KSPSA21FT	24 - 240VAC, positive switching	Onboard	0.1 - 10s	Recycling, On Time First
KSPSN13MI	12 - 120VDC, negative switching	Fixed	3m	Interval
KSPSN21B	12 - 120VDC, negative switching	Onboard	0.1 - 10s	Delay-on-Break
KSPSP145SM	12 - 120VDC, positive switching	Fixed	45s	Delay-on-Make
KSPSP22B	12 - 120VDC, positive switching	Onboard	1 - 100s	Delay-on-Break
KSPSP35PSD	12 - 120VDC, positive switching	External	1 - 100m	Retriggerable Single Shot

If you don't find the part you need, call us for a custom product 800-843-8848

12

TIME DELAY RELAYS

KSPS SERIES

Accessories



P103PM (AL) DIN Rail
35 mm aluminum DIN rail available in a 36 in. (91.4 cm) length.



P1023-20 DIN Rail Adapter
Allows module to be mounted on a 35 mm DIN type rail with two #10 screws.

Specifications

Time Delay

Type	Microcontroller circuitry
Range	0.1s - 1000h in 9 adjustable ranges or fixed
Repeat Accuracy	±0.5% or 20ms, whichever is greater
Tolerance (Factory Calibration)	≤ ±2%
Reset Time	≤ 150ms
Initiate Time	≤ 20ms; ≤ 1500 operations per minute
Time Delay vs Temp. & Voltage	≤ ±2%
Input Voltage	12 to 120VDC; 24 to 240VAC
Tolerance	≤ ±15%
AC Line Frequency/DC Ripple	50/60Hz / ≤ 10%
Power Consumption	AC ≤ 2VA; DC ≤ 1W

Output

Type Solid-state output
Rating 1A steady, 10A inrush for 16ms
Voltage Drop AC ≈ 2.5V @ 1A; DC ≈ 1V @ 1A
OFF State Leakage Current AC ≈ 5mA @ 240VAC, DC ≈ 1mA

Protection

Circuitry Encapsulated
Dielectric Breakdown ≥ 2000V RMS terminals to mounting surface
Insulation Resistance ≥ 100 MΩ
Polarity DC units are reverse polarity protected

Mechanical

Mounting Surface mt. with one #10 (M5 x 0.8) screw
Dimensions **H** 50.8 mm (2.0"); **W** 50.8 mm (2.0");
D 30.7 mm (1.21")

Termination

Environmental
Operating/Storage Temperature -40° to 60°C / -40° to 85°C
Humidity 95% relative, non-condensing
Weight ≈ 2.4 oz (68 g)

Timer Functions

Operation (Delay-on-Make)

Upon application of the input voltage, the time delay begins. The output relay is de-energized before and during the time delay. At the end of the time delay, the output energizes and remains energized until input voltage is removed.

Reset: Removing input voltage resets the time delay and output.

Operation (Delay-on-Break)

Input voltage must be applied before and during timing. Upon closure of the initiate switch, the output relay energizes. The time delay begins when the initiate switch is opened. The output remains energized during timing. At the end of the time delay, the output de-energizes. The output will energize if the initiate switch is closed when input voltage is applied.

Reset: Re-closing the initiate switch during timing resets the time delay. Removing input voltage resets the time delay and output.

Operation (Recycling)

Upon application of input voltage, the output relay energizes and the ON time begins. At the end of the ON time, the output de-energizes and the OFF time begins. At the end of the OFF time, the output energizes and the cycle repeats as long as input voltage is applied.

Reset: Removing input voltage resets the output and time delays, and returns the sequence to the first delay.

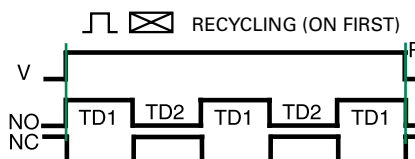
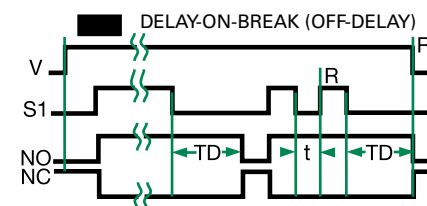
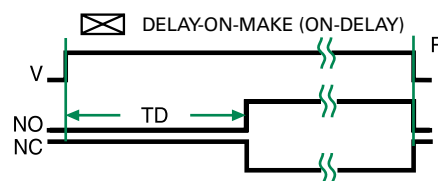

KSPS SERIES

Operation (Alternating)

Input voltage must be applied at all times for proper operation. The operation begins with the output relay de-energized. Closing S1 enables the next alternating operation. When S1 opens (trailing edge triggered), the time delay begins. At the end of the time delay, the output energizes and remains energized until S1 is (re-closed and) re-opened. Then the output relay de-energizes and remains until S1 opens again. Each time S1 opens the time delay occurs and the output transfers.

Reset: Removing input voltage resets the output and the time delay.

Operation (Single Shot)

Input voltage must be applied before and during timing. Upon momentary or maintained closure of the initiate switch, the output (relay or solid state) energizes and the time delay begins. At the end of the delay, the output de-energizes. Opening or re-closing the initiate switch during timing has no effect on the time delay. Note (for most single shot timers): If the initiate switch is closed when input voltage is applied, the output energizes and the time delay begins.

Reset: Reset occurs when the time delay is complete and the initiate switch is opened. Removing input voltage resets the time delay and output.

Operation (Trailing Edge Single Shot, Impulse-OFF)

Input voltage must be applied before and during timing. When the initiate switch S1 opens, the output relay energizes. At the end of the time delay, the output de-energizes. Re-closing and opening S1 during timing has no effect on the time delay. The output will not energize if S1 is open when input voltage is applied.

Reset: Reset occurs when the time delay is complete and S1 is closed. Removing input voltage resets the time delay and output.

Operation (Inverted Single Shot)

Input voltage must be applied before and during timing. Upon momentary or maintained closure of the initiate switch S1, the output relay de-energizes. At the end of the time delay, the output energizes. Opening or re-closing S1 during timing has no effect on the time delay. The output will remain de-energized if S1 is closed when input voltage is applied.

Reset: Reset occurs when the time delay is complete and S1 is open. Removing input voltage resets the time delay and output.

Operation (Interval)

Upon application of input voltage, the time delay begins. The output (relay or solid state) energizes during the time delay. At the end of time delay the output de-energizes and remains de-energized until input voltage is removed.

Reset: Removing input voltage resets the time delay and output.

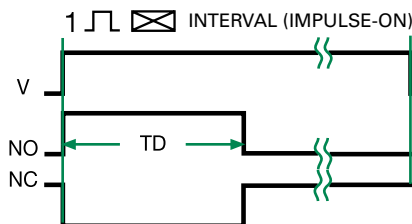
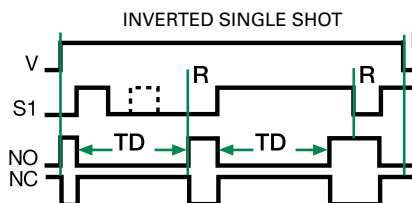
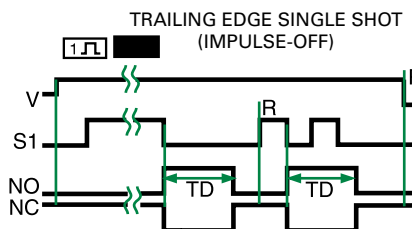
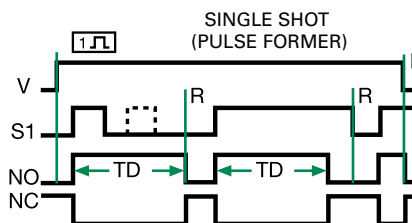
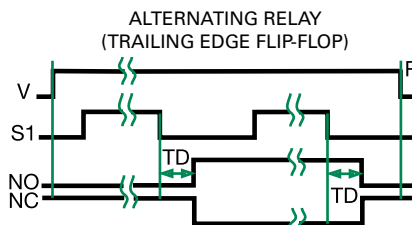

LEGEND

V = Voltage
R = Reset
T1 = ON Time

T2 = OFF Time
S1 = Initiate Switch
NO = Normally Open Contact

NC = Normally Closed Contact
t = Incomplete Time Delay
TD, TD1, TD2 = Time Delay

C = Count
P = Pulse Duration
— = Undefined Time

MSM SERIES

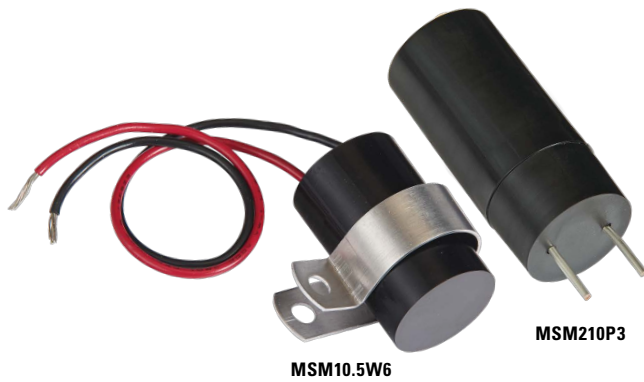

Description

The MSM Series replaces bi-metal type timing with reliable solid-state circuitry. There are no moving parts to arc or wear. It is a cost effective solution for OEM designers. It is available for printed circuit board mounting or surface mounting with a removable bracket and wire leads. The MSM Series offers immediate reset on removal of power.

Operation (Delay-on-Make)

The time delay begins upon application of input voltage. The output is de-energized before and during the time delay. At the end of the time delay, the output energizes and remains energized until input voltage is removed.

Reset: Removing input voltage resets the time delay and output.

Wiring Diagram

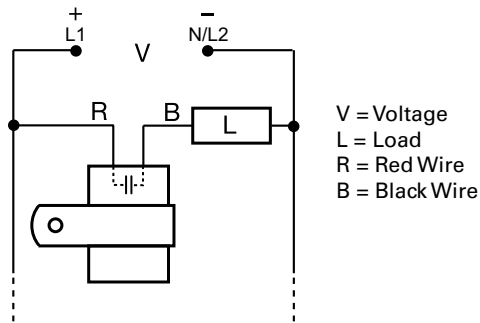

For dimensional drawing see: Appendix, page 514, Figure 39.

Features & Benefits

FEATURES	BENEFITS
Analog circuitry	Repeat Accuracy +/- 5%, Factory calibration +/- 15%
Compact, low cost design	Allows flexibility for OEM applications
Long life	No moving parts to arc or wear
PCB or wire harness	Offers design and installation flexibility
Immediate reset	Occurs on removal of power
Totally Encapsulated	Protects against shock, vibration and humidity

Ordering Information

MODEL	INPUT VOLTAGE	ADJUSTMENT	TIME DELAY	WIRE TYPE	WIRE LENGTH inches (mm)
MSM10.5W6	12VDC	Fixed	0.5s	Standard Lead	6.0 (152.4)
MSM10.7W6	12VDC	Fixed	0.7s	Standard Lead	6.0 (152.4)
MSM11W6	12VDC	Fixed	1s	Standard Lead	6.0 (152.4)
MSM110W6	12VDC	Fixed	10s	Standard Lead	6.0 (152.4)
MSM130W9	12VDC	Fixed	30s	Standard Lead	9.0 (228.6)
MSM190W6	12VDC	Fixed	90s	Standard Lead	6.0 (152.4)
MSM20.15W9	24VAC	Fixed	0.15s	Standard Lead	9.0 (228.6)
MSM210P3	24VAC	Fixed	10s	PC Mount	0.5 (12.7)
MSM25W9	24VAC	Fixed	5s	Standard Lead	9.0 (228.6)
MSM30.7W6	24VDC	Fixed	0.7s	Standard Lead	6.0 (152.4)
MSM42W6	120VAC	Fixed	2s	Standard Lead	6.0 (152.4)
MSM43W6	120VAC	Fixed	3s	Standard Lead	6.0 (152.4)
MSM420W6	120VAC	Fixed	20s	Standard Lead	6.0 (152.4)
MSM450W6	120VAC	Fixed	50s	Standard Lead	6.0 (152.4)

If you don't find the part you need, call us for a custom product 800-843-8848

MSM SERIES

Specifications

Time Delay

Type	Analog Circuitry
Range	0.05 - 180s fixed
Repeat Accuracy	±5%
Tolerance	
(Factory Calibration)	±15%
Recycle Time	≤ 75ms
Time Delay vs Temp. & Voltage	±15%

Input

Voltage	12 or 24VDC; 24, 120, or 230VAC
Tolerance	±10%
AC Line Frequency	50/60 Hz

Output

Type	Solid State
Form	NO, open during timing
Maximum Load Current	0.5A steady state 25°C; 0.25A steady state 60°C

Minimum Holding Current

Voltage Drop	≈ 2.5V @ 0.5A
---------------------	---------------

Protection

Circuitry	Encapsulated
Dielectric Breakdown	≥ 2000V RMS input to mounting surface
Insulation Resistance	≥ 100 MΩ
Polarity	DC units are reverse polarity protected

Mechanical

Mounting	A.) PC mount 14 AWG (2.087mm ²) wires (Can be inserted in AMP Miniature Spring Socket #645980-1) B.) Stranded 18 AWG wire leads (0.933 mm ²) with mounting bracket
-----------------	---

Environmental

Operation/Storage Temperature	-20° to 60°C / -30° to 85°C
Humidity	95% relative, non-condensing
Weight	P: ≈ 1.1 oz (31.2 g) W: ≈ 1.2 oz (34 g)

Function Diagram

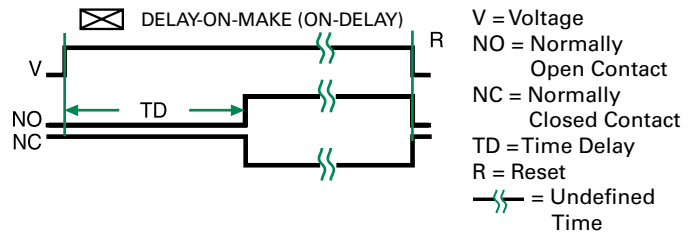

ORM SERIES

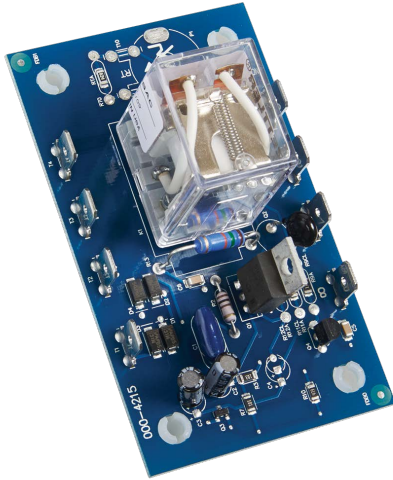

Wiring Diagram

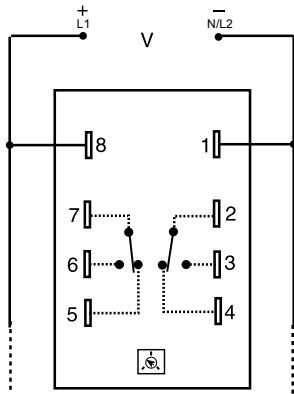

V = Voltage

R_T is used when external adjustment is ordered. Relay contacts are isolated.

For dimensional drawing see: Appendix, page 512, Figure 26.

Ordering Information

MODEL	INPUT VOLTAGE	ADJUSTMENT	TIME DELAY
ORM120A17	120VAC	Fixed	7s
ORM120A25	120VAC	Onboard knob	3 - 300s
ORM230A17	230VAC	Fixed	7s
ORM24D13.5	24VDC/28VDC	Fixed	3.5s
ORM24D22	24VDC	Onboard knob	0.5 - 30s

If you don't find the part you need, call us for a custom product 800-843-8848

Description

The ORM Series features open PC board construction for reduced cost. It has isolated, 10A, DPDT relay contacts and all connections are 0.25 in (6.35 mm) male quick connect terminals. The time delay may be ordered as factory fixed, onboard knob, or external adjustment. Time delays from 0.05 - 300 seconds.

Operation (Delay-on-Make)

Upon application of input voltage, the time delay begins. The output is de-energized before and during the time delay. At the end of the time delay, the output energizes and remains energized until voltage is removed.

Reset: Removing input voltage resets the time delay and output.

Features & Benefits

FEATURES	BENEFITS
Analog circuitry with electromechanical relay	Repeat Accuracy + / - 2%
Isolated 10A, DPDT output contacts	Allows control of loads for AC or DC voltages
Open PCB construction	Reduces cost for OEM applications

Accessories



P1004-12, P1004-12-X Versa-Pot

Panel mountable, industrial potentiometer recommended for remote time delay adjustment.



P0700-7 Versa-Knob

Designed for 0.25 in (6.35 mm) shaft of Versa-Pot. Semi-gloss industrial black finish.



P1015-64 (AWG 14/16)

Female Quick Connect

These 0.25 in. (6.35 mm) female terminals are constructed with an insulator barrel to provide strain relief.



P1015-18 Quick Connect to Screw Adapter

Screw adapter terminal designed for use with all modules with 0.25 in. (6.35 mm) male quick connect terminals.

ORM SERIES

Specifications

Time Delay

Type Analog circuitry
Range 0.05 - 300s in 5 adjustable ranges or fixed
Repeat Accuracy ±2% or 20ms, whichever is greater
Tolerance Adjustable: guaranteed range
 Fixed: ±10%
Recycle Time After timing - ≤ 16ms;
 During timing - 0.1% of max. time delay or 75ms, whichever is greater

Time Delay vs Temp. & Voltage

≤ ±10%

Input

Voltage 24 or 110VDC; 24, 120, or 230VAC

Tolerance

24VDC/AC -15% - 20%

110 to 230VAC/DC -20% - 10%

AC Line Frequency 50/60 Hz

Power Consumption 2.25W

Output

Type Electromechanical relay

Form DPDT, Isolated

Rating 10A resistive @ 120/240VAC & 28VDC;

1/3 hp @ 120/240VAC

Life Mechanical - 1x10⁷; Electrical - 1x10⁶

Protection

Polarity DC units are reverse polarity protected

Isolation Voltage ≥1500V RMS input to output

Mechanical

Mounting Surface mount with four #6 (M3.5 x 0.6) screws

Dimensions **H** 53.8 mm (2.12"); **W** 93.7 mm (3.69");

D 47.8 mm (1.88")

Termination 0.25 in. (6.35 mm) male quick connect terminals

Environmental

Operating/Storage -20° to 65°C / -30° to 85°C

Temperature
Weight ≈ 2.7 oz (77 g)

Selection Guide

R _T Selection Chart					
Desired Time Delay*					R _T
Seconds					
1	2	3	4	5	Megohm
0.05	0.5	0.6	1.2	3.0	0.0
0.5	5.0	10	20	50	0.5
1.0	10	20	40	100	1.0
1.5	15	30	60	150	1.5
2.0	20	40	80	200	2.0
2.5	25	50	100	250	2.5
3.0	30	60	120	300	3.0

* When selecting an external R_T add at least 20% for tolerance of unit and the R_T.

Function Diagram

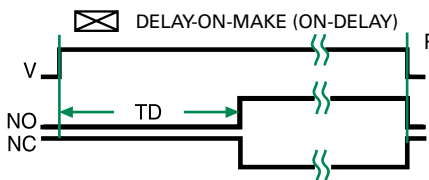

V = Voltage
 NO = Normally Open Contact
 NC = Normally Closed Contact
 TD = Time Delay
 R = Reset
 = Undefined Time

PRLM SERIES



Wiring Diagram

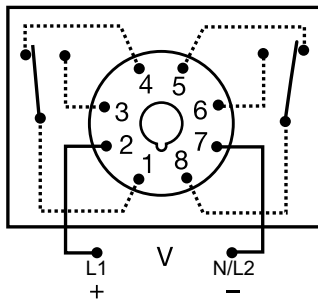

8-pin octal DPDT

For dimensional drawing see: Appendix B, page 512, Figure 24

Ordering Information

MODEL	INPUT VOLTAGE	ADJUSTMENT	TIME DELAY
PRLM41180	120VAC	Fixed	180s
PRLM423	120VAC	Adjustable	1 - 60s

If you don't find the part you need, call us for a custom product 800-843-8848

Description

The PRLM Series is designed for use in non-critical timing applications. It offers low cost, knob adjustable timing control, full 10A relay output, and onboard LED indication. The knob adjustment provides a guaranteed time range of up to 10 minutes in 6 ranges. The onboard LED indicates whether or not the unit is timing (flashing LED) as well as the status of the output.

Operation (Delay-on-Make)

The time delay is initiated when input voltage is applied. LED flashes during timing. At the end of the delay period, the output contacts energize. LED is on steady after the unit times out.

Reset: Reset is accomplished by removal of input voltage. There is no false output when reset during timing.

Features & Benefits

FEATURES	BENEFITS
Electronic circuitry with electromechanical relay	Repeat Accuracy + / - 2%
Knob adjustable time delay	Guaranteed time range of up to 10 mins in 6 ranges
Isolated 10A, DPDT output contacts	Allows control of loads for AC or DC voltages
LED indication	Provides relay status both during and after timing
Industry standard octal plug connection	Eliminates need for special connectors

Accessories



BZ1 Front Panel Mount Kit

Provides an easy method of through-the-panel mounting of 8- or 11-pin plug-in timers, flashers, and other controls.



NDS-8 Octal 8-pin Socket

8-pin 35mm DIN rail or surface mount. Surface mounted with two #6 screws or snaps onto a 35 mm DIN rail. Uses PSC8 hold-down clips.



PSC8 Hold-down Clips

Securely mounts plug-in controls in any position. Provides protection against vibration. Use with NDS-8 Octal Socket. Sold in pairs.



C103PM (AL) DIN Rail

35 mm aluminum DIN rail available in a 36 in. (91.4 cm) length.

PRLM SERIES

Specifications

Time Delay

Type	Analog circuitry
Range	0.05 - 600s in 6 adjustable ranges or fixed
Repeat Accuracy	±2% or 20ms, whichever is greater
Tolerance	Knob adjust: guaranteed range Fixed: ±10%
Reset Time	≤ 50ms
Recycle Time	After timing: ≤ 20ms During timing: 0.1% of max. time delay or 75ms, whichever is greater

Time Delay vs Temp. & Voltage

≤ ±10%

Input

Voltage	12, 24, or 110VDC; 24, 120, or 230VAC
Tolerance	
12VDC & 24VDC/AC	-15% - 20%
110 to 240VAC/DC	-20% - 10%
AC Line Frequency	50/60 Hz
Power Consumption	≤ 2.25W

Output

Type	Electromechanical relay
Form	Isolated, DPDT
Rating	10A resistive @ 28VDC; 10A resistive @ 240VAC; 1/3 hp @ 120/240VAC
Life	Mechanical - 1x10 ⁷ ; Electrical - 1x10 ⁶

Protection

Surge	IEEE C62.41-1991 Level A
Isolation Voltage	≥ 1500V RMS input to output
Insulation Resistance	≥ 100 MΩ
Polarity	DC units are reverse polarity protected

Indication

Type	LED
Operation	During timing - flashing Output energized - on steady

Mechanical

Mounting	Plug-in socket
Dimensions	H 91.6 mm (3.62"); W 60.7 mm (2.39"); D 45.2 mm (1.78")
Termination	Octal 8-pin plug-in

Environmental

Operating/Storage Temperature	-20° to 65°C / -30° to 85°C
Weight	≅ 6 oz (170 g)

Function Diagram

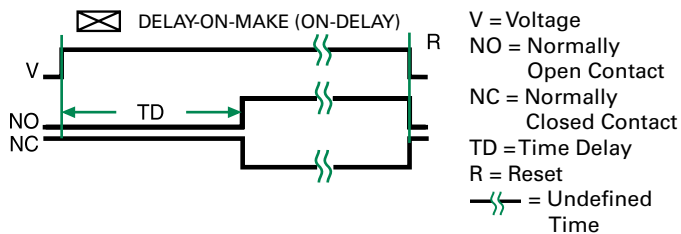

TDM / TDMH / TDML SERIES

Delay-on-Make Timer



*8-pin models UL listed when used in combination with P1011-6 socket only.



Wiring Diagram

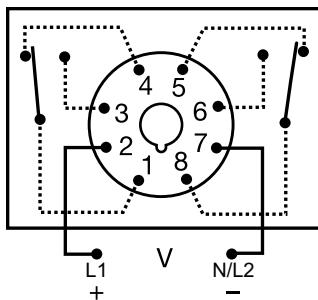

Relay contacts are isolated.

For dimensional drawing see: Appendix, page 512, Figure 23.

Ordering Information

MODEL	INPUT VOLTAGE	DELAY RANGE
TDM120AL	120VAC	1 - 1023s in 1s increments
TDM12DL	12VDC	1 - 1023s in 1s increments
TDM230AL	230VAC	1 - 1023s in 1s increments
TDM24AL	24VAC	1 - 1023s in 1s increments
TDM24DL	24VDC/28VDC	1 - 1023s in 1s increments
TDMH120AL	120VAC	10 - 10230s in 10s increments
TDMH24AL	24VAC	10 - 10230s in 10s increments
TDML110DL	110VDC	0.1 - 102.3s in 0.1s increments
TDML120AL	120VAC	0.1 - 102.3s in 0.1s increments
TDML12DL	12VDC	0.1 - 102.3s in 0.1s increments
TDML24DL	24VDC/28VDC	0.1 - 102.3s in 0.1s increments

If you don't find the part you need, call us for a custom product 800-843-8848

Description

The TDM/TDMH/TDML Series is a delay-on-make timer that combines accurate digital circuitry with isolated, DPDT relay contacts in an industry standard 8-pin plug-in package. DIP switch adjustment allows precise selection of the time delay over the full time delay range. The TDM/TDMH/TDML Series is the product of choice for custom control panel and OEM designers.

Operation (Delay-on-Make)

Upon application of input voltage, the time delay begins. The output is de-energized before and during the time delay. At the end of the time delay, the output relay energizes and remains energized until input voltage is removed.

Reset: Removing input voltage resets the time delay and output.

Features & Benefits

FEATURES	BENEFITS
Wide delay range (0.1s to 2.8h)	User selectable via DIP switches for fine tuning to individual applications.
Microcontroller based	Repeat Accuracy +/- 0.1%
DIP switch adjustment	Provides first time setting accuracy of +/-2%
Setting accuracy +/-2%	Provides flexibility for use in most applications
LED indication	Provides visual indication of time delay status
Isolated 10A, DPDT output contacts	Allows control of loads for AC or DC voltages

Accessories



BZ1 Front Panel Mount Kit

Provides an easy method of through-the-panel mounting of 8- or 11-pin plug-in timers, flashers, and other controls.



NDS-8 Octal 8-pin Socket

8-pin 35mm DIN rail or surface mount. Surface mounted with two #6 screws or snaps onto a 35 mm DIN rail. Uses PSC8 hold-down clips.



PSC8 or PSC11 Hold-down Clips

Securely mounts plug-in controls in any position. Provides protection against vibration. Use PSC8 with NDS-8 Octal Socket or PSC11 with NDS-11 Socket. Sold in sets of two.



P1011-6 Octal Socket for UL listing*

8-pin surface mount socket with binder head screw terminals. Rated 10A @ 600VAC.



C103PM (AL) DIN Rail

35 mm aluminum DIN rail available in a 36 in. (91.4 cm) length.

TDM / TDMH / TDML SERIES

Specifications

Time Delay

Type	Digital integrated circuitry
Range*	0.1 - 102.3s in 0.1s increments 1 - 1023s in 1s increments 10 - 10,230s in 10s increments
Repeat Accuracy	±0.1% or 20ms, whichever is greater
Setting Accuracy	±2% or 50ms, whichever is greater
Reset Time	≤ 50ms
Recycle Time	During Timing - TDMH: ≤ 500ms TDM, TDML: ≤ 300ms

Time Delay vs. Temperature

& Voltage	±2%
Indicator	LED glows during timing; relay is de-energized

Input

Voltage	12, 24, or 110 VDC; 24, 120, or 230VAC
Tolerance	
12VDC & 24VDC/AC	-15% - 20%
110VAC/DC to 230VAC	-20% - 10%
AC Line Frequency	50/60 Hz
Power Consumption	≤ 2.25W

Output

Type	Electromechanical relay
Form	DPDT
Rating	10A resistive @ 120/240VAC & 28VDC; 1/3 hp @ 120/240VAC
Life	Mechanical - 1 x 10 ⁷ ; Electrical - 1 x 10 ⁶

Protection

Polarity	DC units are reverse polarity protected
Isolation Voltage	≥ 1500V RMS input to output

Mechanical

Mounting	Plug-in socket
Dimensions	H 81.3 mm (3.2"); W 60.7 mm (2.39"); D 45.2 mm (1.78")

Termination

Octal 8-pin plug-in

Environmental

Operating/Storage	-20° to 65°C / -30° to 85°C
Temperature	
Weight	≈ 6 oz (170 g)

*For CE approved applications, power must be removed from the unit when a switch position is changed.

Binary Switch Operation

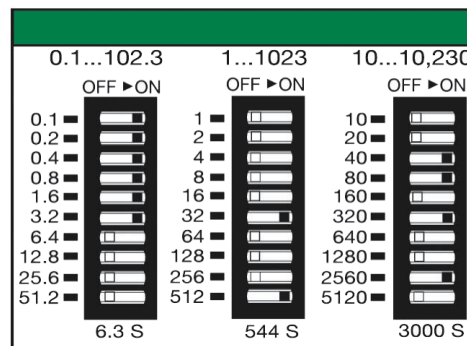

Function Diagram

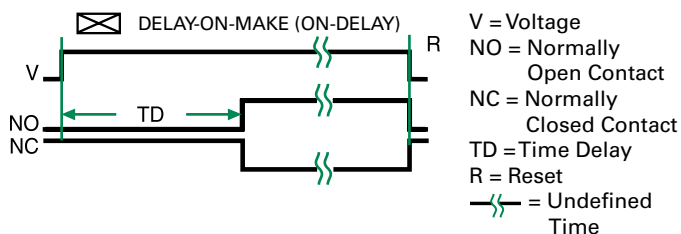

TDU / TDUH / TDUL SERIES

Encapsulated Solid-State,
Delay-on-Make Timers

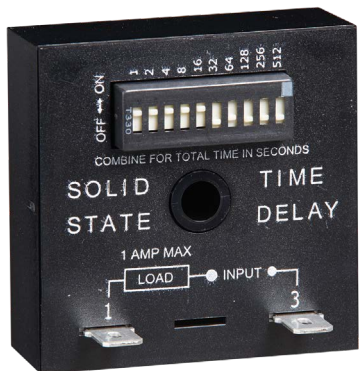

Wiring Diagram

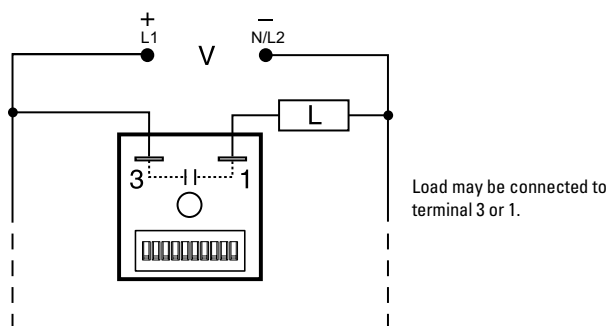

For dimensional drawing see: Appendix, page 512, Figure 16.

Ordering Information

MODEL	INPUT VOLTAGE	TIME RANGE (SEC)
TDUL3000A	24 to 120VAC/DC	0.1-102.3
TDUL3001A	100 to 240VAC/DC	0.1-102.3
TDU3000A	24 to 120VAC/DC	1-1023
TDU3001A	100 to 240VAC/DC	1-1023
TDU3003A	120 to 277VAC/DC	1-1023
TDUH3000A	24 to 120VAC/DC	10-10230
TDUH3001A	100 to 240VAC/DC	10-10230

If you don't find the part you need, call us for a custom product 800-843-8848

Description

The TDU Series are encapsulated solid-state, delay-on-make timers that combine digital timing circuitry with universal voltage operation. The TDU offers DIP switch adjustment allowing accurate selection of the time delay over the full time delay range. This series is an excellent choice for process control systems and OEM equipment.

Operation (Delay-on-Make)

Upon application of input voltage, the time delay begins. The output is de-energized before and during the time delay. At the end of the time delay, the output energizes and remains energized until input voltage is removed.

Reset: Removing input voltage resets the time delay and output.

Features & Benefits

FEATURES	BENEFITS
Universal input voltage	Meets wide application needs
Microcontroller based	Repeat Accuracy +/- 0.5% or 20ms, whichever is greater
Totally solid state and encapsulated	No moving parts to arc and wear out over time, and encapsulated to protect against shock, vibration, and humidity
3 time ranges available (0.1s to 2.8h)	Makes it versatile for use in many applications
DIP switch adjustment	Provides first time setting accuracy

Accessories



P1023-6 Mounting bracket

The 90° orientation of mounting slots makes installation/removal of modules quick and easy.



P1015-64 (AWG 14/16) Female Quick Connect

These 0.25 in. (6.35 mm) female terminals are constructed with an insulator barrel to provide strain relief.



P1015-18 Quick Connect to Screw Adapter

Screw adapter terminal designed for use with all modules with 0.25 in. (6.35 mm) male quick connect terminals.



C103PM (AL) DIN Rail

35 mm aluminum DIN rail available in a 36 in. (91.4 cm) length.



P1023-20 DIN Rail Adapter

Allows module to be mounted on a 35 mm DIN type rail with two #10 screws.

TDU / TDUH / TDUL SERIES

Specifications

Time Delay

Type Digital integrated circuitry
Range* 0.1 - 102.3s in 0.1s increments
 1 - 1,023s in 1s increments
 10 - 10,230s in 10s increments
 $\pm 0.5\%$ or 20ms, whichever is greater

Repeat Accuracy Tolerance (Factory Calibration) $\pm 10\%$

Recycle Time $\leq 150\text{ms}$

Time Delay vs Temp. & Voltage $\pm 5\%$

Input

Voltage 24 to 120VAC/DC; 100 to 240VAC/DC

AC Line Frequency 50/60 Hz

Tolerance $\pm 20\%$

Output

Type Solid state

Form NO, open during timing

Maximum Load Current 1A steady state, 10A inrush at 60°C

Minimum Holding Current 40mA

Voltage Drop $\approx 2.5\text{V @ }1\text{A}$

Protection

Circuitry Encapsulated

Dielectric Breakdown $\geq 2000\text{V RMS}$ terminals to mounting surface

Insulation Resistance $\geq 100\text{ M}\Omega$

Mechanical

Mounting Surface mount with one #10 (M5 x 0.8) screw

Dimensions **H** 50.8 mm (2"); **W** 50.8 mm (2");

D 30.7 mm (1.21")

Termination 0.25 in. (6.35 mm)

male quick connect terminals

Environmental

Operating/Storage

Temperature -40° to 60°C / -40° to 85°C

Humidity 95% relative, non-condensing

Weight $\approx 2.4\text{ oz (68 g)}$

Binary Switch Operation

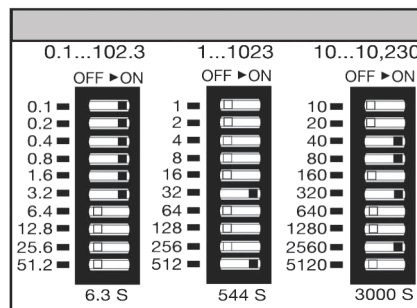

*For CE approved applications, power must be removed from the unit when a switch position is changed.

Function Diagram

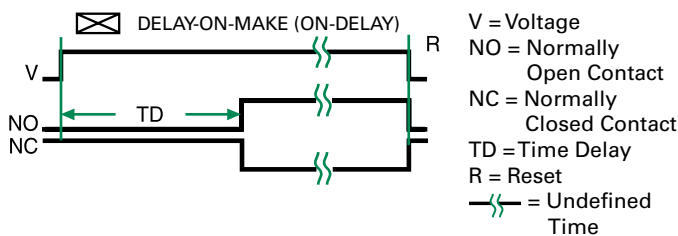

TH1 SERIES

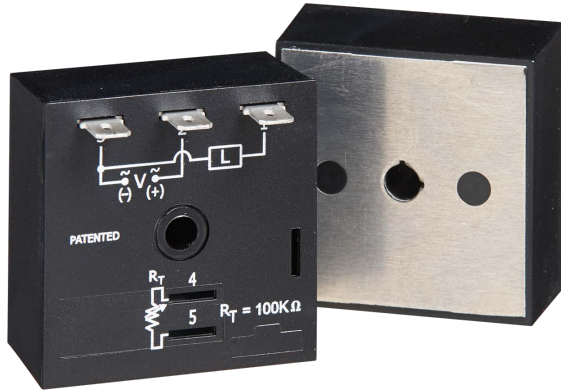

Wiring Diagram

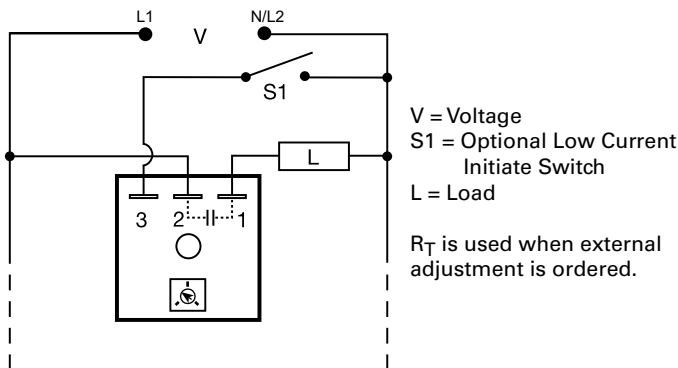

For dimensional drawing see: Appendix, page 512, Figure 19.

Ordering Information

MODEL	OUTPUT RATING	INPUT VOLTAGE	ADJUSTMENT	TIME DELAY
TH1B633	10A	230VAC	Onboard	2 - 180s
TH1C415	20A	120VAC	Fixed	5s
TH1C621	20A	230VAC	External	0.1 - 3s

If you don't find the part you need, call us for a custom product 800-843-8848

Description

The TH1 Series is a solid-state relay and timer combined into one compact, easy-to-use control. This highly reliable device eliminates the need for a separate solid-state relay. When mounted to a metal surface, it can switch load currents up to 20A steady state, and 200A inrush.

Operation (Delay-on-Make)

Upon application of input voltage, the time delay begins. The output is de-energized before and during the time delay. At the end of the time delay, the output energizes and remains energized until input voltage is removed.

Reset: Removing input voltage resets the time delay and output.

Features & Benefits

FEATURES	BENEFITS
Microcontroller based	Repeat Accuracy + / - 2%, Factory calibration + / - 5%
Compact, low cost design	Allows flexibility for OEM applications and reduces labor and component costs
High load currents up to 20A, 200A inrush	Allows direct operation of motors, lamps, and heaters directly without a contactor
Totally solid state and encapsulated	No moving parts to arc and wear out over time and encapsulated to protect against shock, vibration, and humidity
Metalized mounting surface	Facilitates heat transfer for high current applications

Accessories



P1004-95, P1004-95-X Versa-Pot

Panel mountable, industrial potentiometer recommended for remote time delay adjustment.



P0700-7 Versa-Knob

Designed for 0.25 in. (6.35 mm) shaft of Versa-Pot. Semi-gloss industrial black finish.



P1015-13 (AWG 10/12), P1015-64 (AWG 14/16) Female Quick Connect

These 0.25 in. (6.35 mm) female terminals are constructed with an insulator barrel to provide strain relief.



P1015-18 Quick Connect to Screw Adapter

Screw adapter terminal designed for use with all modules with 0.25 in. (6.35 mm) male quick connect terminals.

TH1 SERIES

Specifications

Time Delay

Range 0.1 - 600s in 4 adjustable ranges or fixed
Repeat Accuracy ±2% or 20ms, whichever is greater

Tolerance (Factory Calibration) ≤ ± 5%

Time Delay vs Temp. & Voltage ≤ ±10%

Recycle Time ≤ 150ms

Input

Voltage 24, 120, or 230VAC

Tolerance ±15%

AC Line Frequency 50/60 Hz

Power Consumption ≤ 2VA

Output

Type Solid state

Form NO, open during timing

Maximum Load Currents	Output	Steady State	Inrush**
	A	6A	60A
	B	10A	100A
	C	20A	200A

Minimum Load Current 100mA

Voltage Drop ≅ 2.5V at rated current

OFF State Leakage Current ≅ 5mA @ 230VAC

Protection

Circuitry Encapsulated

Dielectric Breakdown ≥ 2000V RMS terminals to mounting surface

Insulation Resistance ≥ 100 MΩ

Mechanical

Mounting ** Surface mount with one #10 (M5 x 0.8) screw

Dimensions **H** 50.8 mm (2.0"); **W** 50.8 mm (2.0");

D 38.4 mm (1.51")

Termination 0.25 in. (6.35 mm) male quick connect terminals

Environmental

Operating/Storage

Temperature -20° to 60°C / -40° to 85°C

Humidity 95% relative, non-condensing

Weight ≅ 3.9 oz (111 g)

**Must be bolted to a metal surface using the included heat sink compound. The maximum mounting surface temperature is 90°C. Inrush: Non-repetitive for 16ms.

Selection Guide

RT Selection Chart				
Desired Time Delay*				RT
Seconds				
1	2	3	4	Kohms
0.1	0.5	2	5	0
0.3	6	20	60	10
0.6	12	38	120	20
0.9	18	55	180	30
1.2	24	73	240	40
1.5	30	90	300	50
1.8	36	108	360	60
2.1	42	126	420	70
2.4	48	144	480	80
2.7	54	162	540	90
3.0	60	180	600	100

* When selecting an external RT add at least 15% for tolerance of unit and the RT.

Function Diagram

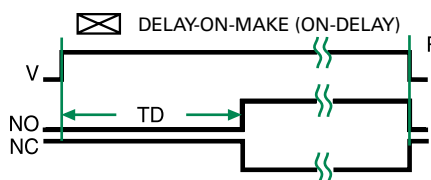

V = Voltage
NO = Normally Open Contact
NC = Normally Closed Contact
TD = Time Delay
R = Reset
—||— = Undefined Time

THD1B410.5S



Description

The THD1B410.5S combines accurate timing circuitry with high power solid-state switching. It can switch motors, lamps, and heaters directly without a contactor. You can reduce labor, component cost, and increase reliability with these small, easy-to-use, timers.

Operation (Delay-on-Make)

Upon application of input voltage, the time delay begins. The output is de-energized before and during the time delay. At the end of the time delay, the output energizes and remains energized until input voltage is removed.

Reset: Removing input voltage resets the time delay and output.

Features & Benefits

FEATURES	BENEFITS
Microcontroller based	Repeat Accuracy + / - 0.5%, Factory calibration + / - 1%
Compact, low cost design	Allows flexibility for OEM applications and reduces labor and component costs
High load currents up to 20A, 200A inrush	Allows direct operation of motors, lamps, and heaters directly without a contactor
Totally solid state and encapsulated	No moving parts to arc and wear out over time and encapsulated to protect against shock, vibration, and humidity
Metalized mounting surface	Facilitates heat transfer for high current applications

Wiring Diagram

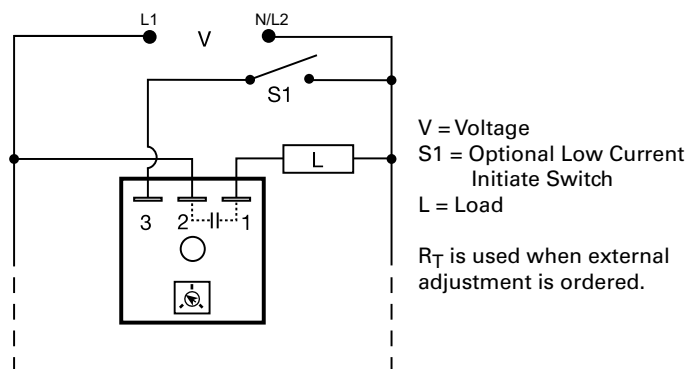

For dimensional drawing see: Appendix, page 512, Figure 19.

Accessories



P1004-95, P1004-95-X Versa-Pot

Panel mountable, industrial potentiometer recommended for remote time delay adjustment.



P0700-7 Versa-Knob

Designed for 0.25 in. (6.35 mm) shaft of Versa-Pot. Semi-gloss industrial black finish.



P1015-13 (AWG 10/12), P1015-64 (AWG 14/16) Female Quick Connect

These 0.25 in. (6.35 mm) female terminals are constructed with an insulator barrel to provide strain relief.



P1015-18 Quick Connect to Screw Adapter

Screw adapter terminal designed for use with all modules with 0.25 in. (6.35 mm) male quick connect terminals.

THD1B410.5S

Specifications

Time Delay

Range 0.1s - 1000m in 6 adjustable ranges or fixed
Repeat Accuracy ±0.5% or 20ms, whichever is greater

Tolerance (Factory Calibration) ≤ ±1%
Recycle Time ≤ 150ms

Time Delay vs Temp. & Voltage ≤ ±2%

Input

Voltage 24, 120, or 230VAC
Tolerance ±20%
Line Frequency 50/60 Hz
Power Consumption ≤ 2VA

Output

Type Solid state
Form NO, open during timing
Maximum Load Current

	Output	Steady State	Inrush**
A		6A	60A
B		10A	100A
C		20A	200A

Minimum Load Current 100mA
Voltage Drop ≅ 2.5V @ rated current
OFF State Leakage Current ≅ 5mA @ 230VAC

Protection

Circuitry Encapsulated
Dielectric Breakdown ≥ 2000V RMS terminals to mounting surface
Insulation Resistance ≥ 100 MΩ

Mechanical

Mounting** Surface mount with one #10 (M5 x 0.8) screw
Dimensions **H** 50.8 mm (2.0"); **W** 50.8 mm (2.0");
D 38.4 mm (1.51")

Termination 0.25 in. (6.35 mm) male quick connect terminals

Environmental

Operating/Storage Temperature -40° to 60°C / -40° to 85°C
Humidity 95% relative, non-condensing
Weight ≅ 3.9 oz (111 g)

External Resistance vs. Time Delay

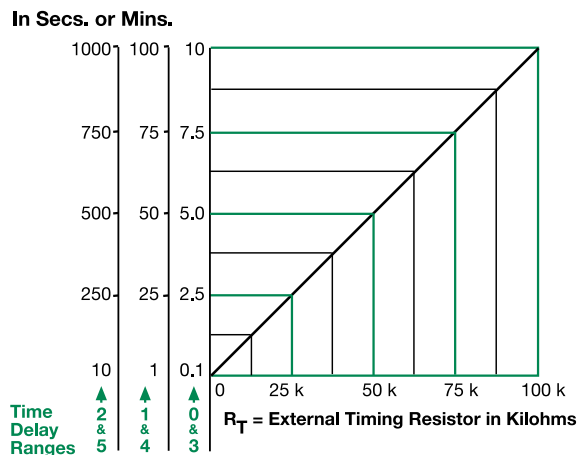

This chart applies to externally adjustable part numbers.
 The time delay is adjustable over the time delay range selected by varying the resistance across the RT terminals; as the resistance increases the tie delay increases.

When selecting an external RT, add the tolerances of the timer and the RT for the full time range adjustment.

Examples: 1 to 50 S adjustable time delay, select time delay range 1 and a 50 K ohm RT. For 1 to 100 S use a 100 K ohm RT.

Function Diagram

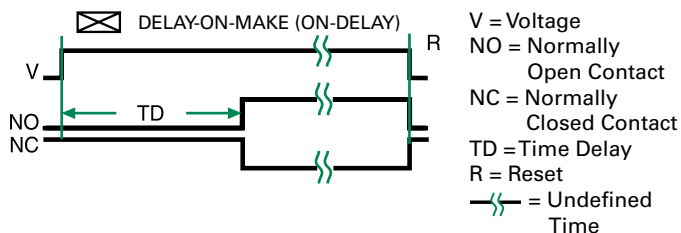

**Must be bolted to a metal surface using the included heat sink compound. The maximum mounting surface temperature is 90°C. Inrush: Non-repetitive for 16ms.

TMV8000 / TSU2000 SERIES

Universal Voltage Delay-on-Make Timer



TMV8000



TSU2000

Description

The TMV and TSU Series are universal voltage delay-on-make timers. Two models cover all the popular voltages and time delays. Available with knob or external adjust time delay. Its simple two terminals can easily be connected in series with a relay coil, contactor coil, solenoid, lamps, small motor, etc., to delay their energization, prevent short cycling or to sequence on various loads.

Operation (Delay-on-Make)

Upon application of input voltage, the time delay begins. The output is de-energized before and during the time delay. At the end of the time delay, the output energizes and remains energized until input voltage is removed.

Reset: Removing input voltage resets the time delay and output.

Wiring Diagram

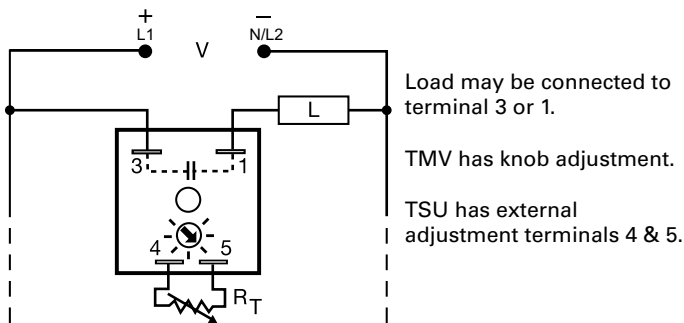

For dimensional drawing see: Appendix, page 512, Figure 16.

Ordering Information

MODEL	INPUT VOLTAGE	ADJUSTMENT	TIME DELAY
TMV8000	24 to 240VAC/DC	Onboard	0.1 - 8m
TSU2000	24 to 240VAC/DC	External	5 - 480s

If you don't find the part you need, call us for a custom product 800-843-8848

Features & Benefits

FEATURES	BENEFITS
Universal AC/DC operating voltage	Provides flexibility for use in all systems
Totally solid-state and encapsulated	No moving parts to arc and wear out over time and encapsulated to protect against shock, vibration, and humidity
Two terminal series connection with the load	Provides quick and easy installation for new or existing systems
1A steady, 10A inrush solid-state output	Provides 100 million operations in typical conditions

Accessories



P1004-95, P1004-95-X Versa-Pot

Panel mountable, industrial potentiometer recommended for remote time delay adjustment.



P1023-6 Mounting bracket

The 90° orientation of mounting slots makes installation/removal of modules quick and easy.



P0700-7 Versa-Knob

Designed for 0.25 in. (6.35 mm) shaft of Versa-Pot. Semi-gloss industrial black finish.



P1015-64 (AWG 14/16) Female Quick Connect

These 0.25 in. (6.35 mm) female terminals are constructed with an insulator barrel to provide strain relief.



P1015-18 Quick Connect to Screw Adapter

Screw adapter terminal designed for use with all modules with 0.25 in. (6.35 mm) male quick connect terminals.

TMV8000 / TSU2000 SERIES

Accessories



C103PM (AL) DIN Rail
35 mm aluminum DIN rail available in a 36 in. (91.4 cm) length.



P1023-20 DIN Rail Adapter
Allows module to be mounted on a 35 mm DIN type rail with two #10 screws.

Selection Guide

R _T Selection Chart	
Time Delay*	
Seconds	R _T Megohm
5	0.0
85	0.5
163	1.0
240	1.5
320	2.0
400	2.5
480	3.0

* When selecting an external R_T add at least 20% for tolerance of unit and the R_T.

Function Diagram

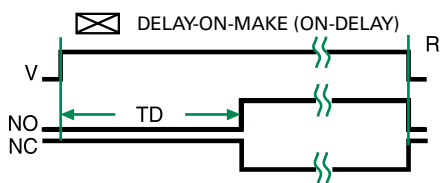

V = Voltage
NO = Normally Open Contact
NC = Normally Closed Contact
TD = Time Delay
R = Reset
—||— = Undefined Time

Specifications

Time Delay

Type Analog circuitry
Range 5 - 480s (TSU2000)
0.1 - 8m (TMV8000)

Repeat Accuracy ±2%
Tolerance (Factory Calibration) ≤ ±10%
Reset Time ≤ 100ms

Input
Voltage 24 to 240VAC/DC ±20%
AC Line Frequency 50/60 Hz

Output
Type Solid State
Form NO, open during timing
Maximum Load Current 1A steady state, 10A inrush at 55°C
Minimum Holding Current ≤ 40mA
Voltage Drop ≈ 2.5V @ 1A

Protection
Circuitry Encapsulated
Dielectric Breakdown ≥ 2000V RMS terminals to mounting surface
Insulation Resistance ≥ 100 MΩ

Mechanical
Mounting Surface mount with one #10 (M5 x 0.8) screw
Dimensions **H** 50.8 mm (2"); **W** 50.8 mm (2");
D 30.7 mm (1.21")
Termination 0.25 in. (6.35 mm) male quick connect terminals

Environmental
Operating/Storage Temperature -20° to 70°C / -30° to 85°C
Humidity 95% relative, non-condensing
Weight ≈ 2.4 oz (68 g)

TRM SERIES



8-PIN



11-PIN



*8-pin models UL listed when used in combination with P1011-6 socket only.

Description

The TRM Series is a combination of analog electronic circuitry and electromechanical relay output. It provides input to output isolation with a wide variety of input voltages and time ranges. Standard plug-in base wiring, fast reset, rugged enclosure, and good repeat accuracy make the TRM a select choice in any OEM application.

Operation (Delay-on-Make)

Upon application of input voltage, the time delay begins. The output is de-energized before and during the time delay. At the end of the time delay, the output relay energizes and remains energized until input voltage is removed.

Reset: Removing input voltage resets the time delay and output.

Wiring Diagram

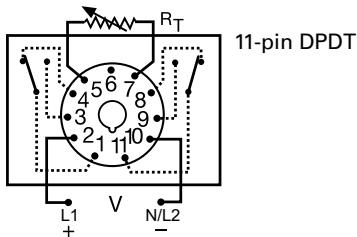
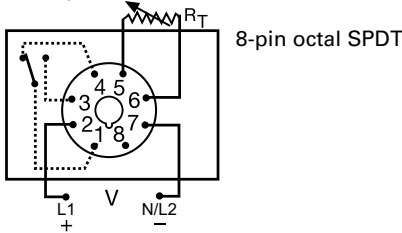
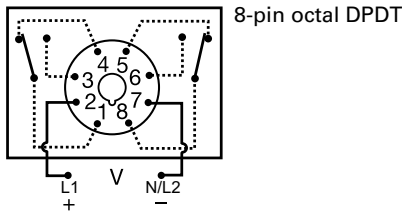

V = Voltage

R_T is used when external adjustment is ordered. Relay contacts are isolated.

For dimensional drawing see: Appendix, page 512, Figure 24.

Features & Benefits

FEATURES	BENEFITS
Electronic circuitry with electromechanical relay	Repeat Accuracy + / - 2%
Isolated 10A, SPDT or DPDT output contacts	Allows control of loads for AC or DC voltages.

Accessories



BZ1 Front Panel Mount Kit

Provides an easy method of through-the-panel mounting of 8- or 11-pin plug-in timers, flashers, and other controls.



NDS-8 Octal 8-pin Socket

8-pin 35mm DIN rail or surface mount. Surface mounted with two #6 screws or snaps onto a 35 mm DIN rail. Uses PSC8 hold-down clips.



NDS-11 11-pin Socket

11-pin 35mm DIN rail or surface mount. Surface mounted with two #6 screws or snaps onto a 35 mm DIN rail. Uses PSC11 hold-down clips.



PSC8 or PSC11 Hold-down Clips

Securely mounts plug-in controls in any position. Provides protection against vibration. Use PSC8 with NDS-8 Octal Socket or PSC11 with NDS-11 Socket. Sold in sets of two.

Ordering Information

MODEL	INPUT VOLTAGE	ADJUSTMENT	OUTPUT	TIME TOLERANCE	TIME DELAY
TRM120A2X30	120VAC	Knob	Octal, DPDT	+/- 20%	1 - 30s
TRM120A2Y120	120VAC	Knob	Octal, DPDT	+/- 10%	2 - 120s
TRM120A2Y180	120VAC	Knob	Octal, DPDT	+/- 10%	2 - 180s
TRM24A8Y5	24VAC	External	Octal, SPDT without potentiometer	+/- 10%	0.1 - 5s
TRM24D1X10	24VDC/28VDC	Fixed	Octal, DPDT	+/- 20%	10s
TRM24D1X2	24VDC/28VDC	Fixed	Octal, DPDT	+/- 20%	2s

If you don't find the part you need, call us for a custom product 800-843-8848

TRM SERIES

Accessories



P1011-6 Octal Socket for UL listing*
8-pin surface mount socket with binder head screw terminals. Rated 10A @ 600VAC.



P1004-13, P1004-13-X Versa-Pot
Panel mountable, industrial potentiometer recommended for remote time delay adjustment.



P0700-7 Versa-Knob
Designed for 0.25 in (6.35 mm) shaft of Versa-Pot. Semi-gloss industrial black finish.

Selection Guides

R _T Selection Chart	
Time Delay*	
Range	R _T
Seconds	Megohm
0.05...1	1.0
0.05...2	2.0
0.05...3	3.0
0.1...5	5.0
0.1...10	3.0
1...30	1.5
1...60	3.0
2...120	2.0
2...180	3.0
7...240	1.5
7...300	2.0
7...360	2.0
7...420	3.0
7...480	3.0
7...600	5.0

External R _T P/N Selection Table	
VALUE	PART NUMBER
1M ohm	P1004-16
1.5M ohm	P1004-15
2M ohm	P1004-14
3M ohm	P1004-12
5M ohm	P1004-13
1M ohm	P1004-16-X
1.5M ohm	P1004-15-X
2M ohm	P1004-14-X
3M ohm	P1004-12-X
5M ohm	P1004-13-X

* When selecting an external R_T add at least 15...30% for tolerance of unit and the R_T.

Function Diagram

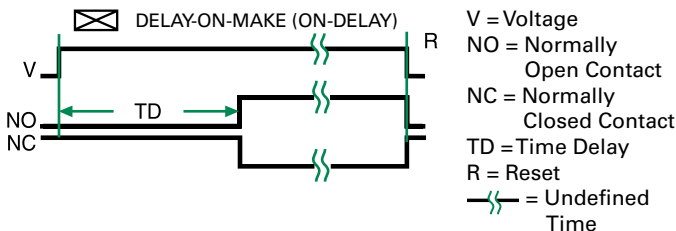

Specifications

Time Delay

Type Analog circuitry
Range 50ms - 10m in 15 adjustable ranges or fixed
Repeat Accuracy ±2% or 20 ms, whichever is greater
Fixed Time Tolerance & Setting Accuracy ±5, 10, or 20%
Reset Time ≤ 50ms
Recycle Time After timing: ≤ 20ms
 During timing: 0.1% of max. time delay or 75ms, whichever is greater

Time Delay vs Temp. & Voltage

≤ ±10%
Input Voltage 24 or 110VDC; 24, 120, or 230VAC

Tolerance -15% - 20%
24VDC/AC -20% - 10%

110 to 230VAC/DC 50/60 Hz
AC Line Frequency ≤ 2.25W
Power Consumption

Output Electromechanical relay
Type Isolated DPDT or SPDT
Form 10A resistive @ 120/240VAC & 28VDC;
 1/3 hp @ 120/240VAC
Rating Mechanical - 1 x 10⁷; Electrical - 1 x 10⁶

Life ≥ 1500V RMS between input & output terminals
Protection ≥ 100 MΩ
Isolation Voltage DC units are reverse polarity protected

Insulation Resistance ≥ 100 MΩ
Polarity DC units are reverse polarity protected

Mechanical Plug-in socket
Mounting **H** 91.6 mm (3.62"); **W** 60.7 mm (2.39");
Dimensions **D** 45.2 mm (1.78")
 Octal 8-pin or 11-pin plug-in

Termination -20° to 65°C / -30° to 85°C
Environmental ≅ 6 oz (170 g)
Operating/Storage
Temperature
Weight

12

TIME DELAY RELAYS

TS1 SERIES

Delay-on-Make Timer



Wiring Diagram

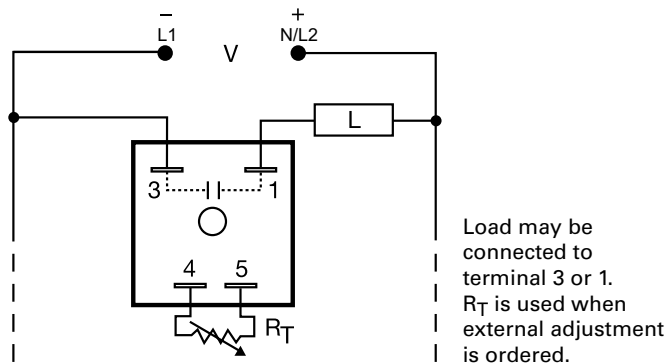

For dimensional drawing see: Appendix, page 512, Figure 16.

Ordering Information

MODEL	INPUT VOLTAGE	ADJUSTMENT	TIME DELAY	MODEL	INPUT VOLTAGE	ADJUSTMENT	TIME DELAY
TS1211.5	24VAC	Fixed	1.5s	TS1412	120VAC	Fixed	2s
TS121150	24VAC	Fixed	150s	TS14120	120VAC	Fixed	20s
TS12130	24VAC	Fixed	30s	TS14130	120VAC	Fixed	30s
TS1214	24VAC	Fixed	4s	TS1415	120VAC	Fixed	5s
TS12190	24VAC	Fixed	90s	TS1416	120VAC	Fixed	6s
TS1221	24VAC	External	0.05 - 3s	TS1421	120VAC	External	0.05 - 3s
TS1222	24VAC	External	0.5 - 60s	TS1422	120VAC	External	0.5 - 60s
TS1224	24VAC	External	5 - 600S	TS1423	120VAC	External	2 - 180s
TS13115	24VDC	Fixed	15s	TS1424	120VAC	External	5 - 600s
TS1321	24VDC	External	0.05 - 3s	TS1612	230VAC	Fixed	2s
TS1410.25	120VAC	Fixed	0.25s	TS1615	230VAC	Fixed	5s
TS14110	120VAC	Fixed	10s	TS1621	230VAC	External	0.05 - 3s
TS141180	120VAC	Fixed	180s	TS1622	230VAC	External	0.5 - 60s

If you don't find the part you need, call us for a custom product 800-843-8848

Description

The TS1 Series offers proven reliability and performance with years of use in OEM equipment and commercial applications. This encapsulated general use timing module is capable of controlling load currents ranging from 5mA to 1A. May be connected in series with contactors, relays, valves, solenoids, small motors, and lamps.

Operation (Delay-on-Make)

Upon application of input voltage, the time delay begins. The output is de-energized before and during the time delay. At the end of the time delay, the output energizes and remains energized until input voltage is removed.

Reset: Removing input voltage resets the time delay and output.

Features & Benefits

FEATURES	BENEFITS
Analog circuitry	Repeat Accuracy +/- 2%
Fixed or external adjustable time delay	External time delay settings are adjustable from 0.05s - 10m in 8 ranges for added flexibility
5mA to 1A load current range	Minimum holding current of 5mA ensures proper operation with the lightest of loads
Totally solid state and encapsulated	No moving parts to arc and wear out over time and encapsulated to protect against shock, vibration, and humidity
Two terminal series load connections	Allows connection in series with contactors, relays, valves, solenoids, small motors and lamps. Provides quick and easy installation for new or existing systems

TS1 SERIES

Accessories



P1004-XX, P1004-XX-X Versa-Pot
Panel mountable, industrial potentiometer recommended for remote time delay adjustment.



P1023-6 Mounting bracket
The 90° orientation of mounting slots makes installation/removal of modules quick and easy.



P0700-7 Versa-Knob
Designed for 0.25 in. (6.35 mm) shaft of Versa-Pot. Semi-gloss industrial black finish.



P1015-64 (AWG 14/16) Female Quick Connect
These 0.25 in. (6.35 mm) female terminals are constructed with an insulator barrel to provide strain relief.



P1015-18 Quick Connect to Screw Adapter
Screw adapter terminal designed for use with all modules with 0.25 in. (6.35 mm) male quick connect terminals.



C103PM (AL) DIN Rail
35 mm aluminum DIN rail available in a 36 in. (91.4 cm) length.



P1023-20 DIN Rail Adapter
Allows module to be mounted on a 35 mm DIN type rail with two #10 screws.



VTP(X)(X) Plug-on Adjustment Module
Mounts on modules with in-line adjustment terminals. Rated at 0.25W at 55°C. Available in resistance values from 5KΩ to 5MΩ.

Selection Table for VTP Plug-on Adjustment Accessory

All Other Voltages		12VDC	
Time Delay	VTP P/N	Time Delay	VTP P/N
1 - 0.05-3s	VTP4B	1 - 0.05-1s	VTP2A
2 - 0.5-60s	VTP4F	2 - 0.5-20s	VTP2E
3 - 2-180s	VTP4J	3 - 2-60s	VTP2F
4 - 5-600s	VTP5N	4 - 5-120s	VTP2H

Specifications

Time Delay

Type Analog circuitry
Range 0.05 - 120s in 4 adjustable ranges or fixed (1 MΩ max. R_T)
12VDC 0.05 - 600s in 4 adjustable ranges or fixed ±2% or 20ms, whichever is greater

Other Voltages 0.05 - 600s in 4 adjustable ranges or fixed ±2% or 20ms, whichever is greater
Repeat Accuracy ≤ ±10%
Tolerance (Factory Calibration) After timing – ≤ 16ms
Recycle Time During timing – 0.1% of time delay or 75ms, whichever is greater

Time Delay vs. Temperature & Voltage

≤ ±10%

Input Voltage 12, 24 or 120VDC; 24, 120, or 230VAC
Tolerance ±20%
AC Line Frequency 50/60 Hz

Output

Type Solid state
Form NO, open during timing
Maximum Load Current 1A steady state, 10A inrush at 60°C
Minimum Holding Current 5mA
Voltage Drop ≈ 2.5V @ 1A

Protection

Circuitry Encapsulated
Dielectric Breakdown ≥ 2000V RMS terminals to mounting surface
Insulation Resistance ≥ 100 MΩ
Polarity DC units are reverse polarity protected

Mechanical

Mounting Surface mount with one #10 (M5 x 0.8) screw
Dimensions **H** 50.8 mm (2"); **W** 50.8 mm (2"); **D** 30.7 mm (1.21")
Termination 0.25 in. (6.35 mm) male quick connect terminals

Termination

Environmental -40° to 80°C / -40° to 85°C
Operating/Storage Temperature 95% relative, non-condensing
Humidity ≈ 2.4 oz (68 g)
Weight

Selection Chart

R _T Selection Chart				
Desired Time Delay*				R _T
Seconds				
1	2	3	4	Megohm
0.05	0.5	2	5	0.0
0.5	10	30	60	0.5
1.0	20	60	120	1.0
▼ 24VDC or AC ONLY† ▼				
1.5	30	90	180	1.5
2.0	40	120	240	2.0
2.5	50	150	300	2.5
3.0	60	180	360	3.0
			420	3.5
			480	4.0
			540	4.5
			600	5.0

* When selecting an external R_T add at least 20% for tolerance of unit and the R_T.
† 1 Megohm max for 12 VDC Units

Function Diagram

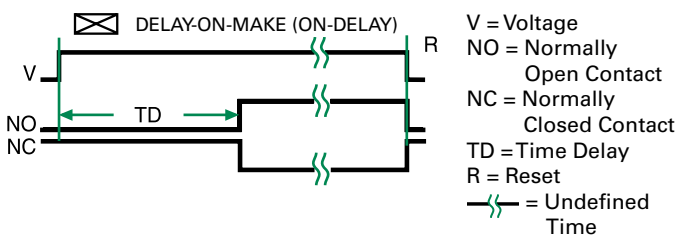

TSD1 SERIES

Delay-on-Make Timer

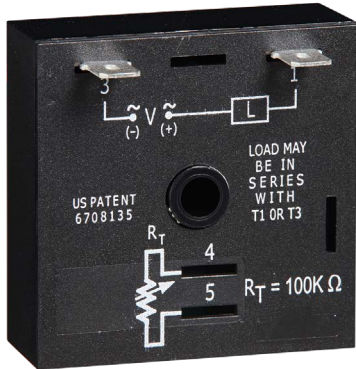

Wiring Diagram

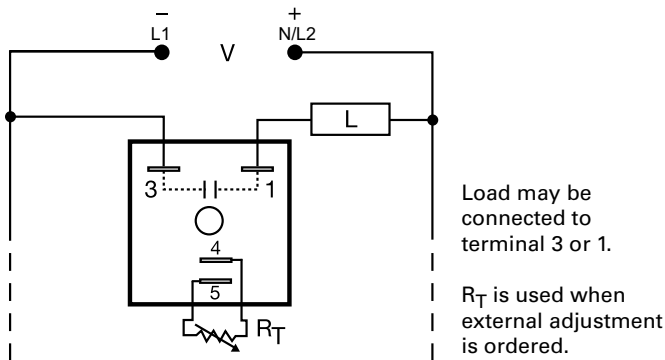

For dimensional drawing see: Appendix, page 512, Figure 16.

Ordering Information

MODEL	INPUT VOLTAGE	ADJUSTMENT	TIME DELAY
TSD1311.2S	24VDC	Fixed	1.2s
TSD1321	24VDC	External	1 - 100s
TSD1424	120VAC	External	1 - 100m

If you don't find the part you need, call us for a custom product 800-843-8848

Description

The TSD1 Series is designed for more demanding commercial and industrial applications where small size and accurate performance is required. The factory calibration for fixed time delays is within 1% of the target time delay. The repeat accuracy, under stable conditions, is 0.1% of the time delay. The TSD1 Series is rated to operate over an extended temperature range. Time delays of 0.1 seconds to 100 hours are available. The output is rated 1A steady and 10A inrush. The modules are totally solid state and encapsulated to protect the electronic circuitry.

Operation (Delay-on-Make)

Upon application of input voltage, the time delay begins. The output is de-energized before and during the time delay. At the end of the time delay, the output energizes and remains energized until input voltage is removed.

Reset: Removing input voltage resets the time delay and output.

Features & Benefits

FEATURES	BENEFITS
Microcontroller based	Repeat Accuracy +/- 0.1%, +/- 1% time delay accuracy
Extended temperature range	Rated to 75°C operating temperature to withstand high heat applications.
Compact, low cost design	Allows flexibility for OEM applications
1A Steady solid-state output, 10A inrush	Provides 100 million operations in typical conditions.
Totally solid state and encapsulated	No moving parts to arc and wear out over time and encapsulated to protect against shock, vibration, and humidity

Accessories



P1004-95, P1004-95-X Versa-Pot

Panel mountable, industrial potentiometer recommended for remote time delay adjustment.



P1023-6 Mounting bracket

The 90° orientation of mounting slots makes installation/removal of modules quick and easy.



P0700-7 Versa-Knob

Designed for 0.25 in. (6.35 mm) shaft of Versa-Pot. Semi-gloss industrial black finish.



P1015-64 (AWG 14/16)

Female Quick Connect

These 0.25 in. (6.35 mm) female terminals are constructed with an insulator barrel to provide strain relief.



P1015-18 Quick Connect to Screw Adapter

Screw adapter terminal designed for use with all modules with 0.25 in. (6.35 mm) male quick connect terminals.

TSD1 SERIES

Accessories



C103PM (AL) DIN Rail
35 mm aluminum DIN rail available in a 36 in. (91.4 cm) length.



P1023-20 DIN Rail Adapter
Allows module to be mounted on a 35 mm DIN type rail with two #10 screws.

External Resistance vs. Time Delay

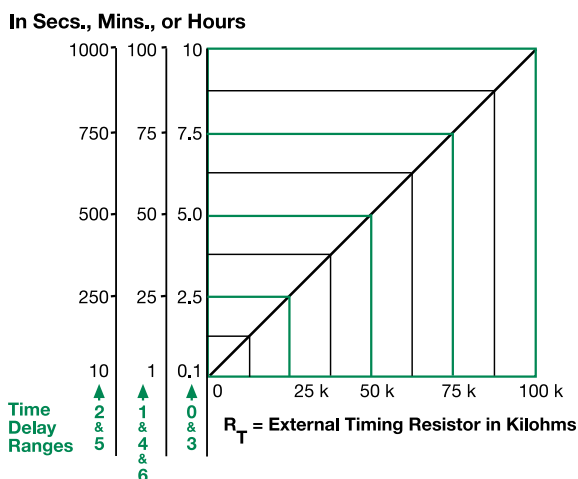

This chart applies to externally adjustable part numbers.

The time delay is adjustable over the time delay range selected by varying the resistance across the R_T terminals; as the resistance increases the time delay increases.

When selecting an external R_T , add the tolerances of the timer and the R_T for the full time range adjustment.

Examples: 1 to 50 S adjustable time delay, select time delay range 1 and a 50 K ohm R_T . For 1 to 100 S use a 100 K ohm R_T .

Specifications

Time Delay

Range 0.1s - 100h in 7 adjustable ranges or fixed
Repeat Accuracy $\pm 0.1\%$ or 20ms, whichever is greater

Tolerance

(Factory Calibration) $\leq \pm 1\%$

Recycle Time

$\leq 150\text{ms}$

Time Delay vs. Temperature

& Voltage $\leq \pm 1\%$

Input

Voltage 12, 24, 120VDC; 24, 120, 230VAC

Tolerance

$\pm 20\%$

AC Line Frequency

50/60 Hz

Output

Type

Solid state

Form

NO, open during timing

Maximum Load Current

1A steady state, 10A inrush at 60°C

Minimum Holding Current

$\leq 40\text{mA}$

Off State Leakage Current

$\approx 7\text{mA}$ @ 230VAC

Voltage Drop

$\approx 2.5\text{V}$ @ 1A

Protection

Circuitry

Encapsulated

Dielectric Breakdown

$\geq 2000\text{V RMS}$ terminals to mounting surface

Insulation Resistance

$\geq 100\text{M}\Omega$

Polarity

DC units are reverse polarity protected

Mechanical

Mounting

Surface mount with one #10 (M5 x 0.8) screw

H 50.8 mm (2"); **W** 50.8 mm (2");

D 30.7 mm (1.21")

Dimensions

0.25 in. (6.35 mm) male quick connect

terminals

Termination

Environmental

Operating/Storage

Temperature

-40° to 75°C / -40° to 85°C

Humidity

95% relative, non-condensing

Weight

$\approx 2.4\text{ oz}$ (68 g)

Function Diagram

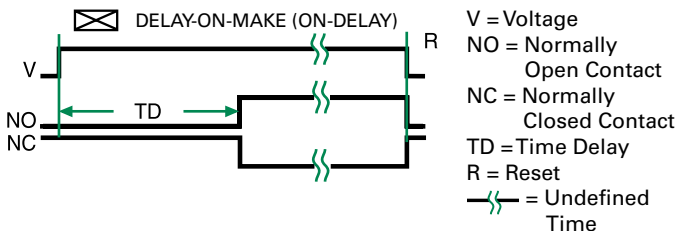

TS441165



Wiring Diagram

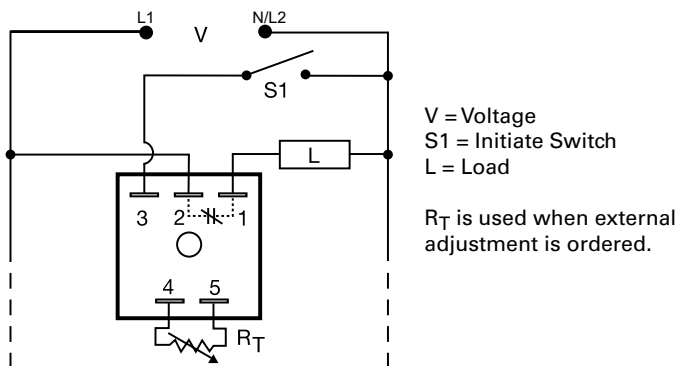

For dimensional drawing see: Appendix, page 512, Figure 16.

Description

The TS441165 is an analog delay-on-make timer with a normally closed solid-state output. Unlike an interval timer, the load is energized prior to and during the time delay period. It can be used as a faster starting interval time delay when S1 is closed upon application of input voltage.

Operation (Delay-on-Make NC)

Upon application of input voltage, the load is energized immediately. When the initiate switch is closed, the time delay begins. At the end of the time delay, the load de-energizes.

Reset: When the initiate switch is reopened, the load again energizes and the time delay is reset. Removing input voltage resets the time delay and output.

Features & Benefits

FEATURES	BENEFITS
Analog circuitry	Repeat Accuracy + / - 2%
Compact, low cost design	Allows flexibility for OEM applications
1A steady, 10A inrush solid-state output	Provides 100 million operations in typical conditions.
Load energized prior to and during time delay	Faster operation
Totally solid state and encapsulated	No moving parts to arc and wear out over time and encapsulated to protect against shock, vibration, and humidity
Normally closed output	Can be used as a faster starting interval time delay

Accessories



P1004-XX, P1004-XX-X Versa-Pot
Panel mountable, industrial potentiometer recommended for remote time delay adjustment.



P1023-6 Mounting bracket
The 90° orientation of mounting slots makes installation/removal of modules quick and easy.



P0700-7 Versa-Knob
Designed for 0.25 in. (6.35 mm) shaft of Versa-Pot. Semi-gloss industrial black finish.



P1015-64 (AWG 14/16) Female Quick Connect
These 0.25 in. (6.35 mm) female terminals are constructed with an insulator barrel to provide strain relief.



P1015-18 Quick Connect to Screw Adapter
Screw adapter terminal designed for use with all modules with 0.25 in. (6.35 mm) male quick connect terminals.



C103PM (AL) DIN Rail
35 mm aluminum DIN rail available in a 36 in. (91.4 cm) length.

TS441165

Accessories



P1023-20 DIN Rail Adapter
Allows module to be mounted on a 35 mm DIN type rail with two #10 screws.



VTP(X)(X) Plug-on Adjustment Module
Mounts on modules with in-line adjustment terminals. Rated at 0.25W at 55°C. Available in resistance values from 5KΩ to 5MΩ.

Selection Table for VTP Plug-on Adjustment Accessory

Time Delay	VTP P/N
1 - 0.05-3s	VTP4B
2 - 0.5-60s	VTP4F
3 - 2-180s	VTP4J
4 - 5-600s	VTP5N

Selection Guide

R _T Selection Chart				
Desired Time Delay*				R _T
Seconds				
1	2	3	4	Megohm
0.05	0.5	2	5	0.0
0.5	10	30	60	0.5
1.0	20	60	120	1.0
1.5	30	90	180	1.5
2.0	40	120	240	2.0
2.5	50	150	300	2.5
3.0	60	180	360	3.0
			420	3.5
			480	4.0
			540	4.5
			600	5.0

* When selecting an external R_T add at least 20% for tolerance of unit and the R_T.

Specifications

Time Delay

Type Analog circuitry
Range 165s
Adjustment Fixed
Repeat Accuracy ±2% or 20ms, whichever is greater; under fixed conditions

Tolerance (Factory Calibration) ≤ ±10%

Time Delay vs Temp. & Voltage ≤ ±10%

Recycle Time ≤ 150ms

Input

Voltage 120VAC

Tolerance ±20%

AC Line Frequency 50/60 Hz

Output

Type Solid state

Form NC, closed during timing

Maximum Load Current 1A steady state, 10A inrush at 60°C

Voltage Drop ≈ 2.5V @ 1A

Protection

Circuitry Encapsulated

Dielectric Breakdown ≥ 2000V RMS terminals to mounting surface

Insulation Resistance ≥ 100 MΩ

Mechanical

Mounting

Surface mount with one #10 (M5 x 0.8) screw

Dimensions

H 50.8 mm (2.0"); **W** 50.8 mm (2.0");

D 30.7 mm (1.21")

Termination

0.25 in. (6.35 mm) male quick connect terminals

Environmental

Operating/Storage

Temperature

-40° to 75°C / -40° to 85°C

Humidity

95% relative, non-condensing

Weight

≈ 2.4 oz (68 g)

Function Diagram

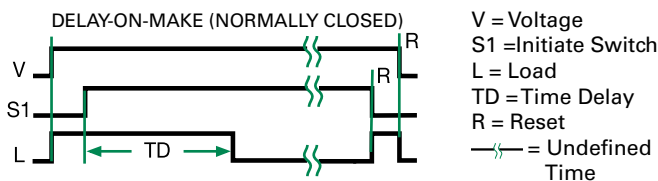

HRDB SERIES

Delay-on-Break Timer



Wiring Diagram

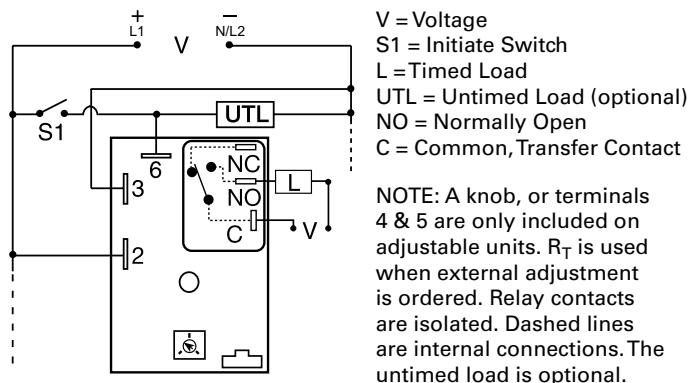

For dimensional drawing see: Appendix, page 512, Figure 17.

Description

The HRDB Series combines an electromechanical, relay output with microcontroller timing circuitry. The HRDB offers 12 to 230V operation in five options and factory fixed, external, or onboard adjustable time delays with a repeat accuracy of $\pm 0.5\%$. The isolated output contact rating allows for direct operation of heavy loads, such as compressors, pumps, blower motors, heaters, etc. The HRDB is ideal for OEM applications where cost is a factor.

Operation (Delay-on-Break)

Input voltage must be applied before and during timing. Upon closure of the initiate switch, the output relay energizes. The time delay begins when the initiate switch is opened. The output remains energized during timing. At the end of the time delay, the output de-energizes. The output will energize if the initiate switch is closed when input voltage is applied.

Reset: Reclosing the initiate switch during timing resets the time delay. Loss of input voltage resets the time delay and output.

Features & Benefits

FEATURES	BENEFITS
Microcontroller based	Repeat Accuracy $\pm 0.5\%$
Compact, low cost design	Allows flexibility for OEM applications
Isolated, 30A, SPDT, NO output contacts	Allows direct operation of heavy loads: compressors, pumps, blower motors, heaters.

Accessories



P1004-95, P1004-95-X Versa-Pot

Panel mountable, industrial potentiometer recommended for remote time delay adjustment.



P1023-6 Mounting bracket

The 90° orientation of mounting slots makes installation/removal of modules quick and easy.



P0700-7 Versa-Knob

Designed for 0.25 in (6.35 mm) shaft of Versa-Pot. Semi-gloss industrial black finish.

Ordering Information

MODEL	INPUT VOLTAGE	ADJUSTMENT	TIME TOLERANCE	TIME DELAY	MODEL	INPUT VOLTAGE	ADJUSTMENT	TIME TOLERANCE	TIME DELAY
HRDB1110M	12VDC	Fixed	$\pm 5\%$	10m	HRDB223	24VAC	Onboard	$\pm 5\%$	0.1 - 10m
HRDB117S	12VDC	Fixed	$\pm 5\%$	7s	HRDB321	24VDC	Onboard	$\pm 5\%$	1 - 100s
HRDB120	12VDC	Onboard	$\pm 5\%$	0.1 - 10s	HRDB324	24VDC	Onboard	$\pm 5\%$	1 - 100m
HRDB121	12VDC	Onboard	$\pm 5\%$	1 - 100s	HRDB423	120VAC	Onboard	$\pm 5\%$	0.1 - 10m
HRDB124	12VDC	Onboard	$\pm 5\%$	1 - 100m	HRDB623	230VAC	Onboard	$\pm 5\%$	0.1 - 10m
HRDB21A65M	24VAC	Fixed	$\pm 1\%$	65m					

If you don't find the part you need, call us for a custom product 800-843-8848

HRDB SERIES

Accessories



P1015-13 (AWG 10/12), **P1015-64** (AWG 14/16) **Female Quick Connect**
These 0.25 in. (6.35 mm) female terminals are constructed with an insulator barrel to provide strain relief.



P1015-18 Quick Connect to Screw Adapter
Screw adapter terminal designed for use with all modules with 0.25 in. (6.35 mm) male quick connect terminals.



C103PM (AL) DIN Rail
35 mm aluminum DIN rail available in a 36 in. (91.4 cm) length.



P1023-20 DIN Rail Adapter
Allows module to be mounted on a 35 mm DIN type rail with two #10 screws.

External Resistance vs. Time Delay

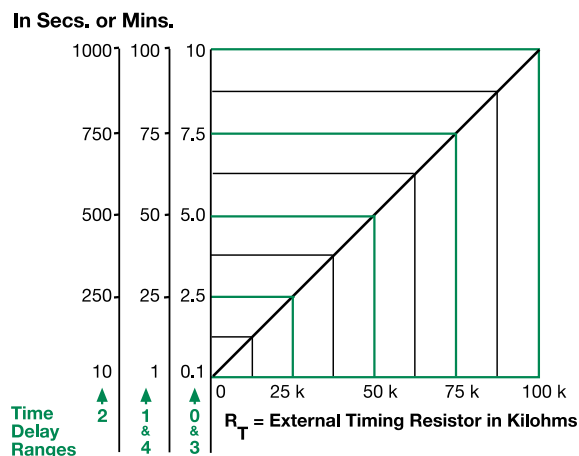

This chart applies to externally adjustable part numbers.
The time delay is adjustable over the time delay range selected by varying the resistance across the R_T terminals; as the resistance increases the time delay increases.
When selecting an external R_T , add the tolerances of the timer and the R_T for the full time range adjustment.
Examples: 1 to 50 S adjustable time delay, select time delay range 1 and a 50 K ohm R_T . For 1 to 100 S use a 100 K ohm R_T .

Function Diagram

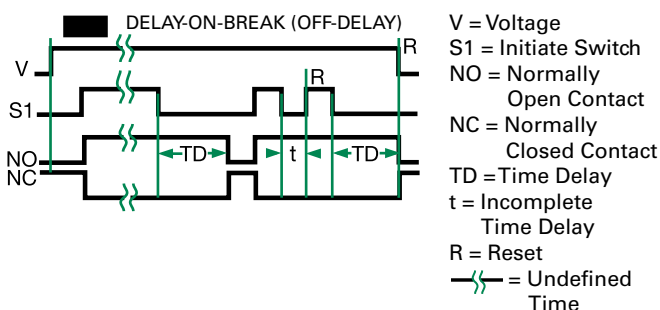

Specifications

Time Delay

Type Microcontroller circuitry
Range 0.1s - 100m in 5 adjustable ranges or fixed
Repeat Accuracy ±0.5 % or 20ms, whichever is greater

Tolerance ±1%, ±5%
(Factory Calibration)

Reset Time ≤ 150ms

Initiate Time ≤ 20ms

Time Delay vs Temp. & Voltage ±2%

Input

Voltage 12 or 24VDC; 24, 120, or 230VAC

Tolerance

12VDC & 24VDC -15% - 20%

24 to 230VAC -20% - 10%

AC Line Frequency 50/60 Hz

Power Consumption AC ≤ 4VA; DC ≤ 2W

Output

Type Electromechanical relay

Form Isolated, SPDT

Ratings

	SPDT-NO	SPDT-NC
General Purpose Resistive	125/240VAC 30A	15A
	125/240VAC 30A	15A
	28VDC 20A	10A

Motor Load

125VAC 1 hp*

240VAC 2 hp**

Life

Mechanical - 1 x 10⁶;

Electrical - 1 x 10⁵, *3 x 10⁴, **6,000

Protection

Surge IEEE C62.41-1991 Level A

Circuitry Encapsulated

Dielectric Breakdown ≥ 2000V RMS terminals to mounting surface

Insulation Resistance ≥ 100 MΩ

Polarity DC units are reverse polarity protected

Mechanical

Mounting

Surface mount with one #10 (M5 x 0.8) screw

H 50.8 mm (2"); **W** 50.8 mm (2");

D 38.1 mm (1.51")

0.25 in. (6.35 mm) male quick connect terminals

Termination

Environmental

Operating/Storage

Temperature

-40° to 60°C / -40° to 85°C

Humidity

95% relative, non-condensing

Weight

≈ 3.9 oz (111 g)

HRPS / HRIS SERIES



Wiring Diagram

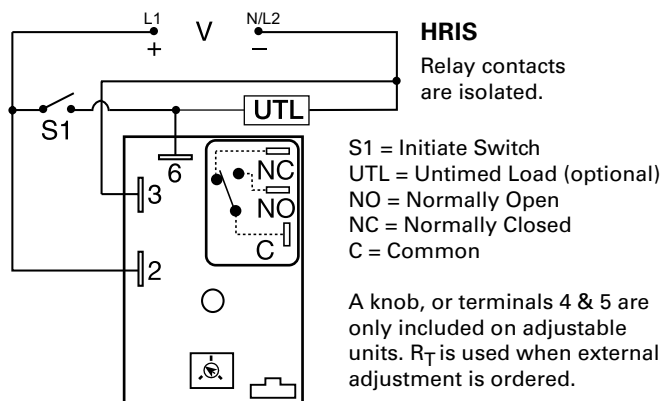
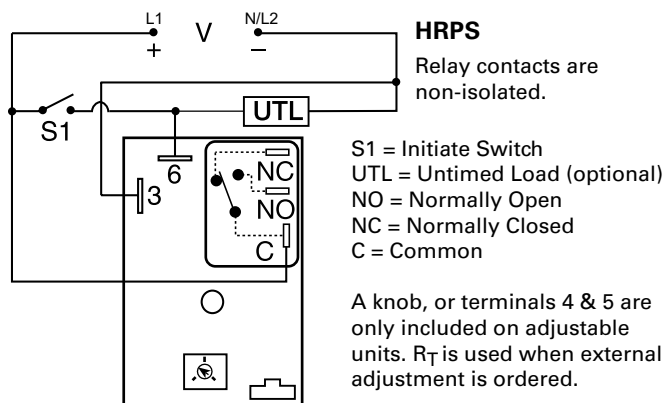

For dimensional drawing see: Appendix, page 512, Figure 17.

Description

The HRPS/HRIS Series combines an electromechanical relay output with microcontroller timing circuitry. It is a factory programmed module available in any 1 of 13 standard functions. It offers 12 to 240V operation in two universal ranges and factory fixed, onboard, or external adjustable time delays with a repeat accuracy of $\pm 0.5\%$. The output contact rating allows for direct operation of heavy loads, such as compressors, pumps, blower motors, heaters, etc. This series is ideal for OEM applications where cost is a factor. The HRPS has non-isolated SPDT relay contacts, and the HRIS has isolated SPDT relay contacts. Both offer the most popular timer functions in the industry.

Operation (Interval)

Upon application of input voltage, the time delay begins. The output (relay or solid state) energizes during the time delay. At the end of time delay the output de-energizes and remains de-energized until input voltage is removed.

Reset: Removing input voltage resets the time delay and output.

Features & Benefits

FEATURES	BENEFITS
Microcontroller based	Repeat Accuracy +/- 0.5%, factory calibration +/- 2%
Compact design	Allows flexibility for OEM applications
30A, SPDT, Normally Open output contacts	Allows for direct operation of heavy loads
Encapsulated	Protects against shock, vibration, and humidity

Ordering Information

MODEL	INPUT VOLTAGE	ADJUST.	TIME DELAY	FUNCTION
HRISW21FT	24 - 240VAC/24 - 110VDC	Onboard	0.1 - 10s	Alternating
HRISW27I	24 - 240VAC/24 - 110VDC	Onboard	0.1 - 10h	Interval
HRPSD12HI	12 - 48VDC	Fixed	2h	Interval
HRISW25B	24 - 240VAC/24 - 110VDC	Onboard	1 - 100m	Delay on break

If you don't find the part you need, call us for a custom product 800-843-8848

HRPS / HRIS SERIES

Accessories



P1004-95, P1004-95-X Versa-Pot
Panel mountable, industrial potentiometer recommended for remote time delay adjustment.



P1023-6 Mounting bracket
The 90° orientation of mounting slots makes installation/removal of modules quick and easy.



P0700-7 Versa-Knob
Designed for 0.25 in. (6.35 mm) shaft of Versa-Pot. Semi-gloss industrial black finish.



P1015-64 (AWG 14/16), P1015-13 (AWG 10/12) Female Quick Connect
These 0.25 in. (6.35 mm) female terminals are constructed with an insulator barrel to provide strain relief.



P1015-18 Quick Connect to Screw Adapter
Screw adapter terminal designed for use with all modules with 0.25 in. (6.35 mm) male quick connect terminals.



C103PM (AL) DIN Rail
35 mm aluminum DIN rail available in a 36 in. (91.4 cm) length.



P1023-20 DIN Rail Adapter
Allows module to be mounted on a 35 mm DIN type rail with two #10 screws.

Function Diagrams

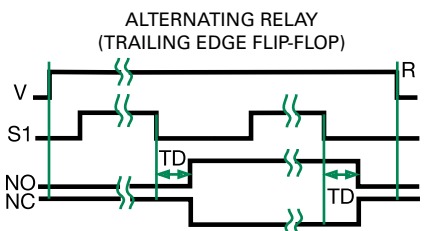
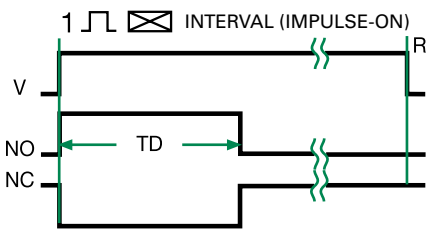

V = Voltage
S1 = Initiate Switch
NO = Normally Open Contact
NC = Normally Closed Contact
TD = Time Delay
R = Reset
— = Undefined Time

Specifications

Time Delay

Type Microcontroller circuitry
Range 0.1s - 1000h in 9 adjustable ranges or fixed
Repeat Accuracy ±0.5% or 20ms, whichever is greater

Tolerance (Factory Calibration) ±2%

Reset Time ≤ 150ms

Initiate Time ≤ 20ms

Time Delay vs Temp. & Voltage ±2%

Input Voltage 12 to 48VDC; 24 to 240VAC/24 to 110VDC

Tolerance 12 to 48VDC -15% - 20%

24 to 110VDC/240VAC -20% - 10%

AC Line Frequency 50/60Hz

Power Consumption AC ≤ 4VA; DC ≤ 2W

Output

Type Electromechanical relay

Form SPDT

Ratings	SPDT-NO	SPDT-NC
General Purpose		
125/240VAC	30A	15A
Resistive		
125/240VAC	30A	15A
28VDC	20A	10A
Motor Load		
125VAC	1 hp*	1/4 hp**
240VAC	2 hp**	1 hp**

General Purpose

125/240VAC

Resistive

125/240VAC

28VDC

Motor Load

125VAC

240VAC

Life

Mechanical - 1 x 10⁶

Electrical - 1 x 10⁵, *3 x 10⁴, **6,000

Protection

Surge IEEE C62.41-1991 Level A

Circuitry Encapsulated

Isolation Voltage ≥ 1500V RMS input to output; isolated units

Insulation Resistance ≥ 100 MΩ

Polarity DC units are reverse polarity protected

Mechanical

Mounting Surface mt. with one #10 (M5 x 0.8) screw

Dimensions **H** 76.2 mm (3.0"); **W** 50.8 mm (2.0");

D 38.1 mm (1.5")

0.25 in. (6.35 mm) male quick connects

Termination

Environmental

Operating/Storage

Temperature

-40° to 60°C / -40° to 85°C

Humidity

95% relative, non-condensing

Weight

≈ 3.9 oz (111 g)

12

TIME DELAY RELAYS

KRDB SERIES



Wiring Diagram

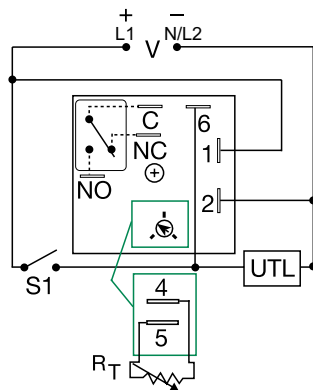

V = Voltage
S1 = Initiate Switch
C = Common, Transfer Contact
NO = Normally Open
NC = Normally Closed
UTL = Untimed Load (optional)

A knob is supplied for adjustable units. The untimed load is optional. Relay contacts are isolated.

For dimensional drawing see: Appendix, page 512, Figure 16.

Description

The KRDB Series is a compact time delay relay measuring only 2 in. (50.8 mm) square. Its microcontroller timing circuit provides excellent repeat accuracy and stability. Encapsulation protects against shock, vibration, and humidity. The KRDB Series is a cost effective approach for OEM applications that require small size, isolation, reliability, and long life.

Operation (Delay-on-Break)

Input voltage must be applied before and during timing. Upon closure of the initiate switch, the output relay energizes. The time delay begins when the initiate switch is opened. The output remains energized during timing. At the end of the time delay, the output de-energizes. The output will energize if the initiate switch is closed when input voltage is applied.

Reset: Reclosing the initiate switch during timing resets the time delay. Loss of input voltage resets the time delay and output.

Features & Benefits

FEATURES	BENEFITS
Microcontroller based	Repeat accuracy +/- 0.5%, Factory calibration +/- 5%
Isolated, 10A, SPDT output contacts	Allows control of loads for AC or DC voltages
Encapsulated	To protect against shock, vibration, and humidity
Compact, low cost design measuring 2 in. (50.8mm) square	Allows flexibility for OEM applications

Accessories



P1004-95, P1004-95-X Versa-Pot

Panel mountable, industrial potentiometer recommended for remote time delay adjustment.



P1023-6 Mounting bracket

The 90° orientation of mounting slots makes installation/removal of modules quick and easy.



P0700-7 Versa-Knob

Designed for 0.25 in. (6.35 mm) shaft of Versa-Pot. Semi-gloss industrial black finish.

Ordering Information

MODEL	INPUT VOLTAGE	ADJUSTMENT	TIME DELAY	MODEL	INPUT VOLTAGE	ADJUSTMENT	TIME DELAY
KRDB110.1S	12VDC	Fixed	0.1s	KRDB31120S	24VDC	Fixed	20s
KRDB112.5S	12VDC	Fixed	2.5s	KRDB415S	120VAC	Fixed	5s
KRDB1120M	12VDC	Fixed	20m	KRDB4160S	120VAC	Fixed	60s
KRDB115M	12VDC	Fixed	5m	KRDB420	120VAC	Onboard	0.1 - 10s
KRDB120	12VDC	Onboard	0.1 - 10s	KRDB421	120VAC	Onboard	1 - 100s
KRDB124	12VDC	Onboard	1 - 100m	KRDB422	120VAC	Onboard	10 - 1000s
KRDB21180S	24VAC/DC	Fixed	180s	KRDB423	120VAC	Onboard	0.1 - 10m
KRDB217S	24VAC/DC	Fixed	7s	KRDB424	120VAC	Onboard	1 - 100m

If you don't find the part you need, call us for a custom product 800-843-8848

KRDB SERIES

Accessories



P1015-64 (AWG 14/16)
Female Quick Connect
These 0.25 in. (6.35 mm) female terminals are constructed with an insulator barrel to provide strain relief.



P1015-18 Quick Connect to Screw Adapter
Screw adapter terminal designed for use with all modules with 0.25 in. (6.35 mm) male quick connect terminals.



C103PM (AL) DIN Rail
35 mm aluminum DIN rail available in a 36 in. (91.4 cm) length.

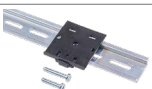

P1023-20 DIN Rail Adapter
Allows module to be mounted on a 35 mm DIN type rail with two #10 screws.

External Resistance vs. Time Delay

In Secs. or Mins.

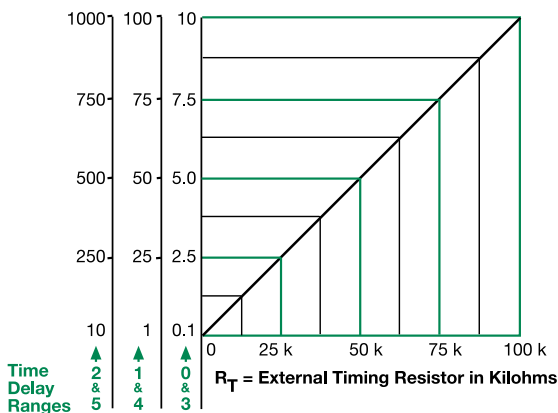

This chart applies to externally adjustable part numbers.
The time delay is adjustable over the time delay range selected by varying the resistance across the R_T terminals; as the resistance increases the time delay increases.

When selecting an external R_T , add the tolerances of the timer and the R_T for the full time range adjustment.

Examples: 1 to 50 S adjustable time delay, select time delay range 1 and a 50 K ohm R_T . For 1 to 100 S use a 100 K ohm R_T .

Output Current/Ambient Temperature

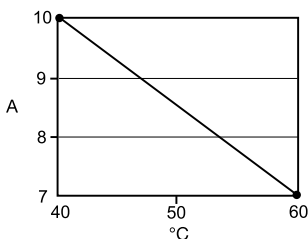

Specifications

Time Delay

Type	Microcontroller with watchdog circuitry
Range	0.1s - 1000ms in 6 adjustable ranges or fixed
Repeat Accuracy	±0.5% or 20ms, whichever is greater
Tolerance	
(Factory Calibration)	≤ ±5%
Recycle Time	≤ 150ms
Initiate Time	≤ 40ms
Time Delay vs Temp. & Voltage	≤ ±5%

Input

Voltage	12, 24, 110VDC; 24, 120 or 230VAC
Tolerance	
12VDC & 24VDC/AC	-15% - 20%
110VDC, 120 or 230VAC	-20% - 10%
AC Line Frequency/DC Ripple	50/60 Hz / ≤ 10%
Power Consumption	AC ≤ 2VA; DC ≤ 2W

Output

Type	Isolated relay contacts
Form	SPDT
Rating (at 40°C)	10A resistive @ 125VAC; 5A resistive @ 230VAC & 28VDC; 1/4 hp @ 125VAC
Max. Switching Voltage	250VAC
Life (Operations)	Mechanical - 1×10^7 ; Electrical - 1×10^5
Protection	
Circuitry	Encapsulated
Isolation Voltage	≥ 1500V RMS input to output
Insulation Resistance	≥ 100 MΩ
Polarity	DC units are reverse polarity protected
Mechanical	
Mounting	Surface mount with one #10 (M5 x 0.8) screw
Dimensions	H 50.8 mm (2.0"); W 50.8 mm (2.0"); D 30.7 mm (1.21") 0.25 in. (6.35 mm) male quick connect terminals

Termination

Environmental

Operating/Storage Temperature	-40° to 60°C / -40° to 85°C
Humidity	95% relative, non-condensing
Weight	≈ 2.6 oz (74 g)

Function Diagram

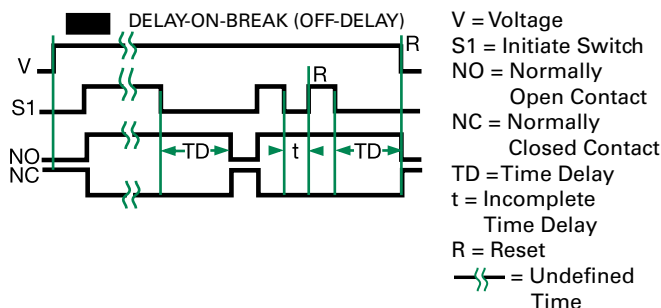

KSDB SERIES



Wiring Diagram

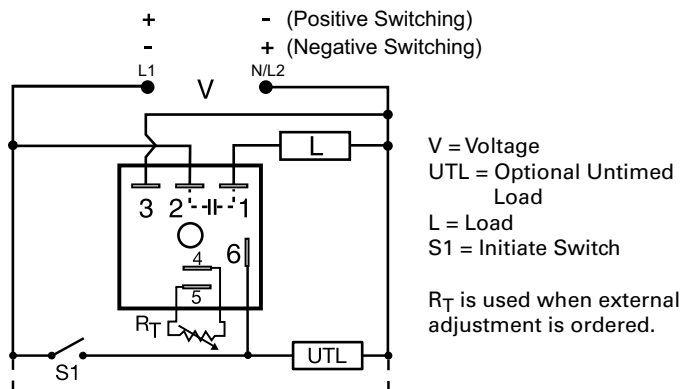

For dimensional drawing see: Appendix, page 512, Figure 16.

Description

The KSDB Series is designed for general purpose commercial and industrial applications where a small, cost effective, reliable solid-state timer is required. The factory calibration for fixed time delays is within 5% of the target time delay. The repeat accuracy, under stable conditions, is 0.5% of the selected time delay. This series is designed for popular AC and DC voltages. Time delays of 0.1 seconds to 1000 minutes are available in 6 ranges. The output is rated 1A steady and 10A inrush. The modules are totally solid state and encapsulated to protect the electronic circuitry.

Operation (Delay-on-Break)

Input voltage must be applied before and during timing. Upon closure of the initiate switch, the output energizes. The time delay begins when the initiate switch is opened. The output remains energized during timing. At the end of the time delay, the output de-energizes. The output energizes if the initiate switch is closed when input voltage is applied.

Reset: Reclosing the initiate switch during timing resets the time delay. Loss of input voltage resets the time delay and output.

Features & Benefits

FEATURES	BENEFITS
Microcontroller based	Repeat accuracy +/- 0.5%, Factory calibration +/- 5%
1A Steady, 10A inrush solid-state output	Provides 100 million operations in typical conditions.
Totally solid state and encapsulated	No moving parts to arc and wear out over time and encapsulated to protect against shock, vibration, and humidity
Compact, low cost design	Allows flexibility for OEM applications

Ordering Information

MODEL	INPUT VOLTAGE	ADJUSTMENT	TIME DELAY	SWITCHING MODE	MODEL	INPUT VOLTAGE	ADJUSTMENT	TIME DELAY	SWITCHING MODE
KSDB1110MP	12VDC	Fixed	10m	Positive	KSDB314SP	24VDC	Fixed	4s	Positive
KSDB1115SP	12VDC	Fixed	15s	Positive	KSDB315SP	24VDC	Fixed	5s	Positive
KSDB1120SP	12VDC	Fixed	20s	Positive	KSDB324N	24VDC	External	1 - 100m	Negative
KSDB113MP	12VDC	Fixed	3m	Positive	KSDB330N	24VDC	Onboard	0.1 - 10s	Negative
KSDB113SP	12VDC	Fixed	3s	Positive	KSDB4120M	120VAC	Fixed	20m	n/a
KSDB120P	12VDC	External	0.1 - 10s	Positive	KSDB4160S	120VAC	Fixed	60s	n/a
KSDB134P	12VDC	Onboard	1 - 100m	Positive	KSDB4190M	120VAC	Fixed	90m	n/a
KSDB2115S	24VAC	Fixed	15s	n/a	KSDB431	120VAC	Onboard	1 - 100s	n/a
KSDB220	24VAC	External	0.1 - 10s	n/a	KSDB61150S	230VAC	Fixed	150s	n/a
KSDB231	24VAC	Onboard	1 - 100s	n/a	KSDB631	230VAC	Onboard	1 - 100s	n/a

If you don't find the part you need, call us for a custom product 800-843-8848

KSDB SERIES

Accessories



P1004-95, P1004-95-X Versa-Pot
Panel mountable, industrial potentiometer recommended for remote time delay adjustment.



P1023-6 Mounting bracket
The 90° orientation of mounting slots makes installation/removal of modules quick and easy.



P0700-7 Versa-Knob
Designed for 0.25 in. (6.35 mm) shaft of Versa-Pot. Semi-gloss industrial black finish.



P1015-64 (AWG 14/16), P1015-14 (AWG 18/22) Female Quick Connect
These 0.25 in. (6.35 mm) female terminals are constructed with an insulator barrel to provide strain relief.



P1015-18 Quick Connect to Screw Adapter
Screw adapter terminal designed for use with all modules with 0.25 in. (6.35 mm) male quick connect terminals.



C103PM (AL) DIN Rail
35 mm aluminum DIN rail available in a 36 in. (91.4 cm) length.



P1023-20 DIN Rail Adapter
Allows module to be mounted on a 35 mm DIN type rail with two #10 screws.

External Resistance vs. Time Delay

In Secs. or Mins.

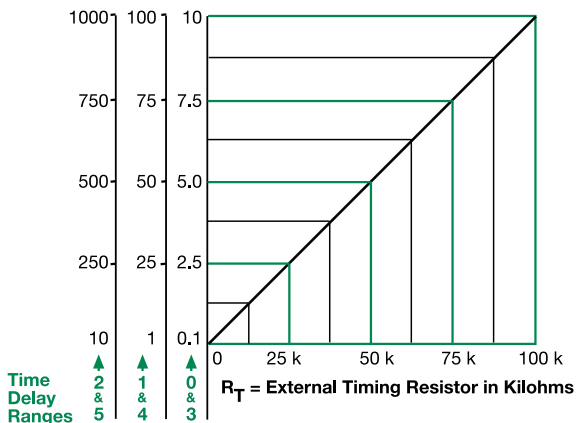

This chart applies to externally adjustable part numbers.
The time delay is adjustable over the time delay range selected by varying the resistance across the R_T terminals; as the resistance increases the time delay increases.

When selecting an external R_T , add the tolerances of the timer and the R_T for the full time range adjustment.

Examples: 1 to 50 S adjustable time delay, select time delay range 1 and a 50 K ohm R_T . For 1 to 100 S use a 100 K ohm R_T .

Specifications

Time Delay Range	0.1s - 1000m in 6 adjustable ranges or fixed
Repeat Accuracy Tolerance (Factory Calibration)	$\pm 0.5\%$ or 20ms, whichever is greater
Reset Time	$\leq 5\%$
Initiate Time	$\leq 150\text{ms}$
Time Delay vs Temp. & Voltage	$\leq 20\text{ms}$
Input Voltage	$\leq \pm 10\%$
Tolerance	12, 24, or 120VDC; 24, 120, or 230VAC
Power Consumption	$\pm 20\%$
AC Line Frequency/DC Ripple	AC $\leq 2\text{VA}$; DC $\leq 2\text{W}$
Output Type	50/60 Hz / $\leq 10\%$
Form	Solid state
Maximum Load Current	NO, closed before & during timing
OFF State Leakage Current	1A steady state, 10A inrush at 60°C
Voltage Drop	AC $\approx 5\text{mA}$ @ 230VAC; DC $\approx 1\text{mA}$
DC Operation	AC $\approx 2.5\text{V}$ @ 1A; DC $\approx 1\text{V}$ @ 1A
Protection	Positive or negative switching
Circuitry	Encapsulated
Dielectric Breakdown	$\geq 2000\text{V RMS}$ terminals to mounting surface
Insulation Resistance	$\geq 100\text{M}\Omega$
Polarity	DC units are reverse polarity protected
Mechanical Mounting Dimensions	Surface mount with one #10 (M5 x 0.8) screw H 50.8 mm (2.0"); W 50.8 mm (2.0"); D 30.7 mm (1.21")
Termination	0.25 in. (6.35 mm) male quick connect terminals
Environmental Operating/Storage Temperature	-40° to 60°C / -40° to 80°C
Humidity	95% relative, non-condensing
Weight	$\approx 2.4\text{ oz}$ (68 g)

Function Diagram

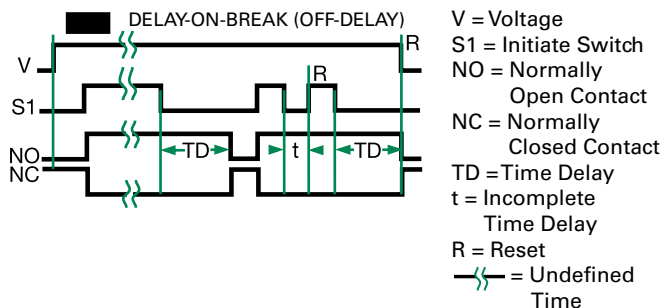

12 TIME DELAY RELAYS

ORB SERIES

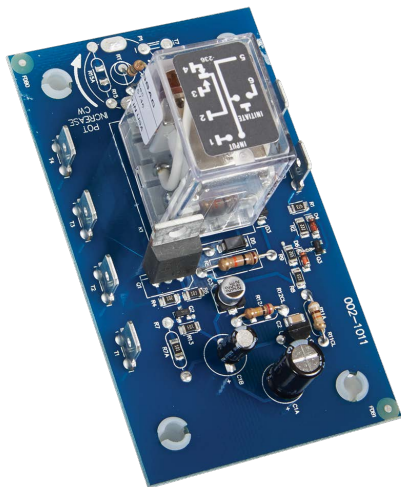

Wiring Diagram

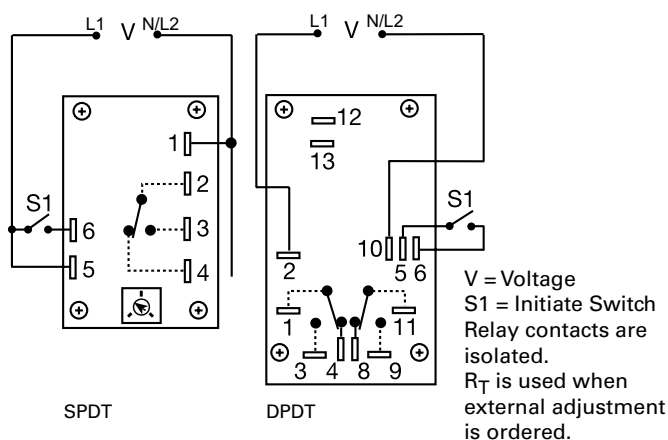

For dimensional drawing see: Appendix, page 512, Figure 26.

Ordering Information

MODEL	INPUT VOLTAGE	ADJUSTMENT	TIME DELAY	OUTPUT FORM
ORB120A160	120VAC	Fixed	60s	SPDT
ORB120A25	120VAC	Onboard	3 - 300s	SPDT
ORB24A11D	24VAC	Fixed	1s	DPDT
ORB24A21D	24VAC	Onboard	0.05 - 3s	DPDT
ORB24A25	24VAC	Onboard	3 - 300s	SPDT

If you don't find the part you need, call us for a custom product 800-843-8848

Description

The ORB Series' open PCB construction offers the user good economy without sacrificing performance and reliability. The output relay is available in isolated, 10A, DPDT or SPDT forms. The time delay may be ordered as factory fixed, onboard knob, or external adjustment. All connections are 0.25 in. (6.35 mm) male quick connect terminals.

Operation (Delay-on-Break)

Input voltage must be applied before and during timing. Upon closure of the initiate switch, the output relay energizes. The time delay begins when the initiate switch is opened (trailing edge triggered). The output remains energized during timing. At the end of the time delay, the output de-energizes. The output will energize if the initiate switch is closed when input voltage is applied.

Reset: Reclosing the initiate switch during timing resets the time delay. Loss of input voltage resets the time delay and output.

Features & Benefits

FEATURES	BENEFITS
Open PCB construction	Reduces cost for OEM applications
Analog circuitry	Repeat accuracy +/- 2%, Factory calibration +/- 10%
Isolated, 10A, SPDT or DPDT output contacts	Allows control of loads for AC or DC voltages
Line voltage initiation	Separate control voltage is not required for operation

Accessories



P1004-12, P1004-12-X Versa-Pot

Panel mountable, industrial potentiometer recommended for remote time delay adjustment.



P0700-7 Versa-Knob

Designed for 0.25 in. (6.35 mm) shaft of Versa-Pot. Semi-gloss industrial black finish.



P1015-64 (AWG 14/16)

Female Quick Connect

These 0.25 in. (6.35 mm) female terminals are constructed with an insulator barrel to provide strain relief.



P1015-18 Quick Connect to Screw Adapter

Screw adapter terminal designed for use with all modules with 0.25 in. (6.35 mm) male quick connect terminals.

ORB SERIES

Specifications

Time Delay

Type Analog circuitry
Range 0.05 - 300s in 5 adjustable ranges or fixed
Repeat Accuracy ±2% or 20ms, whichever is greater

Tolerance (Factory Calibration) Adjustable: guaranteed range
Fixed: ±10%

Reset Time ≤ 50ms

Initiate Time ≤ 70ms

Time Delay vs Temp. & Voltage ≤ ±10%

Input Voltage 24, 120, or 230VAC

Tolerance 24VAC -15% - 20%

120 & 230VAC -20% - 10%

AC Line Frequency 50/60 Hz

Power Consumption 2.25W

Output Type Electromechanical relay
Form Isolated, SPDT or DPDT
Rating 10A resistive @ 120/240VAC & 28VDC;
1/3 hp @ 120/240VAC

Life Mechanical - 1x10⁷; Electrical - 1x10⁶

Protection Isolation Voltage ≥1500V RMS input to output

Mechanical Mounting Dimensions Surface mount with four #6 (M3.5 x 0.6) screws
H 53.8 mm (2.12"); **W** 93.7 mm (3.69");
D 47.8 mm (1.88")

Termination 0.25 in. (6.35 mm) male quick connect terminals

Environmental Operating/Storage Temperature -20° to 65°C / -30° to 85°C
Weight ≈ 2.7 oz (77 g)

Selection Guides

R _T Selection Chart					
Desired Time Delay*					R _T Megohm
Seconds					
1	2	3	4	5	
0.05	0.5	0.6	1.2	3.0	0.0
0.5	5.0	10	20	50	0.5
1.0	10	20	40	100	1.0
1.5	15	30	60	150	1.5
2.0	20	40	80	200	2.0
2.5	25	50	100	250	2.5
3.0	30	60	120	300	3.0

* When selecting an external R_T add at least 20% for tolerance of unit and the R_T.

Function Diagram

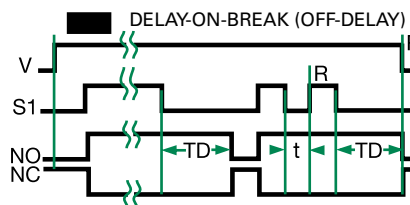

V = Voltage
S1 = Initiate Switch
NO = Normally Open Contact
NC = Normally Closed Contact
TD = Time Delay
t = Incomplete Time Delay
R = Reset
— = Undefined Time

TDB / TDBH / TDBL SERIES

Relay Output, Delay-on-Break



*8-pin models UL listed when used in combination with P1011-6 socket only.



8-PIN



11-PIN

Wiring Diagram

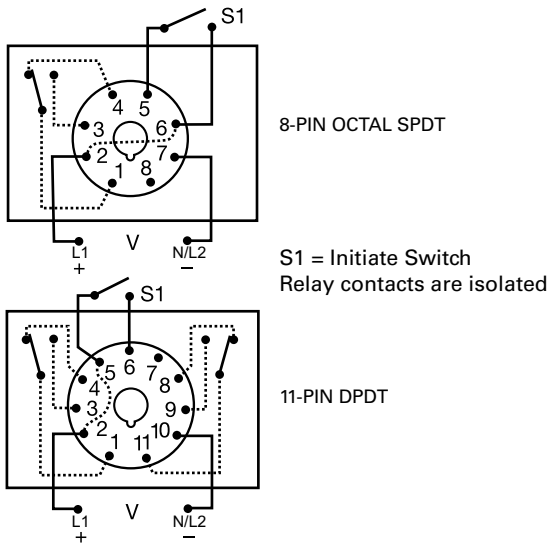

Description

The TDB Series combines accurate digital circuitry with isolated, 10A, DPDT or SPDT contacts in an 8-pin or 11-pin plug-in package. The TDB Series features DIP switch selectable time delays ranging from 0.1-10,230 seconds in three ranges. The TDB Series is the product of choice for custom control panel and OEM designers.

Operation (Delay-on-Break)

Input voltage must be applied to the input before and during timing. Upon closure of the initiate switch, the output relay is energized. The time delay begins when the initiate switch is opened (trailing edge triggered). The output remains energized during timing. At the end of the time delay, the output de-energizes. The output will energize if the initiate switch is closed when input voltage is applied.

Reset: Reclosing the initiate switch during timing resets the time delay. Loss of input voltage resets the time delay and output.

Features & Benefits

FEATURES	BENEFITS
3 time ranges available (0.1s to 2.8h)	Makes it versatile for use in many applications
Microcontroller based	Repeat Accuracy + / - 0.1% or 20ms, whichever is greater; Setting Accuracy + / - 2% or 50ms, whichever is greater
LED indication (select models)	Provides visual indication of relay status
DIP switch adjustment	Provides first time setting accuracy
Isolated output contacts	Allows control of loads for AC or DC voltages

For dimensional drawing see: Appendix, page 512, Figure 23.

Ordering Information

MODEL	INPUT VOLTAGE	DELAY RANGE (SEC)	LED	TYPE PLUG/OUTPUT FORM
TDB120AL	120VAC	1-1023 in 1s increments	X	Octal (8-pin) plug, SPDT
TDB120ALD	120VAC	1-1023 in 1s increments	X	11-pin plug, DPDT
TDB12D	12VDC	1-1023 in 1s increments		Octal (8-pin) plug, SPDT
TDB230AL	230VAC	1-1023 in 1s increments	X	Octal (8-pin) plug, SPDT
TDB24AL	24VAC	1-1023 in 1s increments	X	Octal (8-pin) plug, SPDT
TDB24DL	24VDC/ 28VDC	1-1023 in 1s increments	X	Octal (8-pin) plug, SPDT
TDBH120AL	120VAC	10-10230 in 10s increments	X	Octal (8-pin) plug, SPDT
TDBH120ALD	120VAC	10-10230 in 10s increments	X	11-pin plug, DPDT
TDBL120AL	120VAC	0.1-102.3 in 0.1s increments	X	Octal (8-pin) plug, SPDT
TDBL120ALD	120VAC	0.1-102.3 in 0.1s increments	X	11-pin plug, DPDT
TDBL24DL	24VDC/ 28VDC	0.1-102.3 in 0.1s increments	X	Octal (8-pin) plug, SPDT

If you don't find the part you need, call us for a custom product 800-843-8848

TDB / TDBH / TDBL SERIES

Accessories



BZ1 Front Panel Mount Kit
Provides an easy method of through-the-panel mounting of 8- or 11-pin plug-in timers, flashers, and other controls.



NDS-8 Octal 8-pin Socket
8-pin 35mm DIN rail or surface mount. Rated at 10A @ 300VAC. Surface mounted with two #6 (M 3.5 x 0.6) screws or snaps onto a 35 mm DIN rail. Uses PSC8 hold-down clips.



NDS-11 11-pin Socket
11-pin 35mm DIN rail or surface mount. Rated at 10A @ 300VAC. Surface mounted with two #6 (M 3.5 x 0.6) screws or snaps onto a 35 mm DIN rail. Uses PSC11 hold-down clips.



PSC8 or PSC11 Hold-down Clips
Securely mounts plug-in controls in any position. Provides protection against vibration. Use PSC8 with NDS-8 Octal Socket or PSC11 with NDS-11 Socket. Sold in pairs.



PSCR8 Hold-down Brackets
Designed for use with P1011-6 socket. Securely mounts 8-pin plug-in controls in any position, and provides protection against vibration. Sold in pairs.



P1011-6 Octal Socket for UL listing
8-pin surface mount socket with binder head screw terminals. Rated 10A @ 600VAC. Combination is UL Listed when used with TDB Series timers. Use PSCR8 Hold-down brackets.

Digi-Set Binary Switch Operation

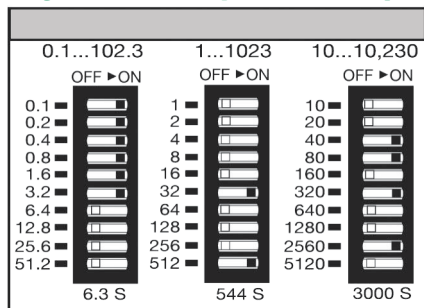

** For CE approved applications, power must be removed from the unit when a switch position is changed.

Specifications

Time Delay

Type	Digital integrated circuitry
Range**	0.1 - 102.3s in 0.1s increments 1 - 1023s in 1s increments 10 - 10,230s in 10s increments
Repeat Accuracy	±0.1% or 20ms, whichever is greater
Setting Accuracy	±2% or 50ms, whichever is greater
Reset Time	≤ 50ms
Recycle Time	≤ 150ms
Time Delay vs Temp. & Voltage	±5%
Indicator	LED indicates relay is energized
Initiate Time	≤ 60ms

Input

Voltage	12, 24/28, or 110VDC; 24, 120, or 230VAC
Tolerance	
12VDC & 24VDC/AC	-15% - 20%
110 to 230VAC/DC	-20% - 10%
AC Line Frequency	50/60 Hz
Power Consumption	≤ 3.25W

Output

Type	Electromechanical relay
Form	SPDT or DPDT
Rating	10A resistive @ 120/240VAC & 28VDC; 1/3 hp @ 120/240VAC
Life	Mechanical - 1 x 10 ⁷ ; Electrical - 1 x 10 ⁶

Protection

Isolation Voltage	≥ 1500V RMS input to output
Polarity	DC units reverse polarity protected

Mechanical

Mounting	Plug-in socket
Dimensions	H 81.3 mm (3.2"); W 60.7 mm (2.4"); D 45.2 mm (1.8")
Termination	Octal 8-pin plug-in or 11-pin plug-in

Environmental

Operating/Storage Temperature	-20° to 65°C / -30° to 85°C
Weight	≈ 6 oz (170 g)

Function Diagram

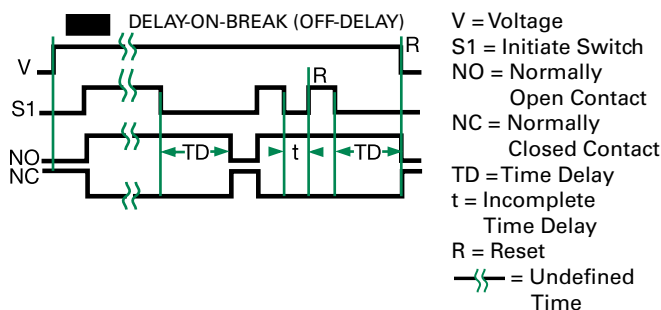

TDUB SERIES

Delay-on-Break Timer

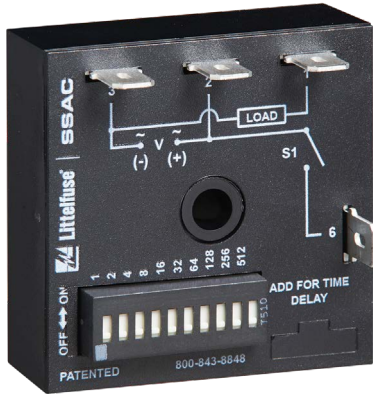

Wiring Diagram

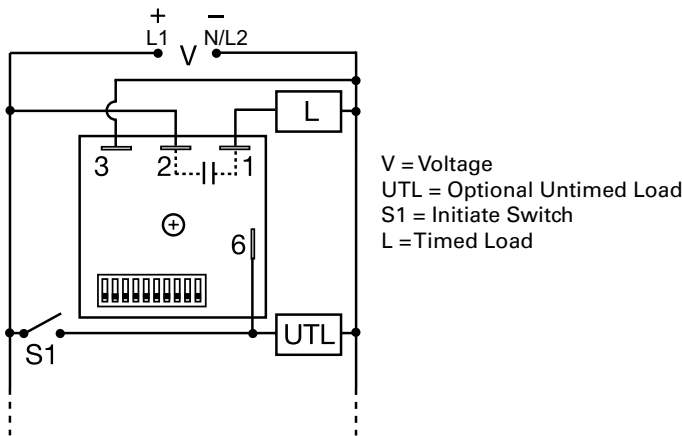

For dimensional drawing see: Appendix, page 512, Figure 16.

Ordering Information

MODEL	INPUT VOLTAGE RANGE	TIME RANGE
TDUB3000A	24 to 120VAC	1-1023s
TDUB3002A	12 to 24VDC	1-1023s
TDUBH3002A	12 to 24VDC	0.1-102.3m
TDUBH3001A	100 to 240VAC	0.1-102.3m
TDUBL3002A	12 to 24VDC	0.1-102.3s

If you don't find the part you need, call us for a custom product 800-843-8848

Description

The TDUB Series combines digital timing circuitry with universal voltage operation. Voltages of 24 to 240VAC and 12 to 24VDC are available in three ranges. The TDUB Series offers DIP switch selectable time delays ranging from 0.1 seconds to 102.3 minutes in three ranges. Its 1A rated output, ability to operate on multiple voltages, and wide range of switch selectable time delays make the TDUB Series an excellent choice for process control systems and OEM equipment.

Operation (Delay-on-Break)

Input voltage must be applied before and during timing. Upon closure of the initiate switch, the output energizes. The time delay begins when the initiate switch is opened (trailing edge triggered). The output remains energized during timing. At the end of the time delay, the output de-energizes. The output will energize if the initiate switch is closed when input voltage is applied.

Reset: Reclosing the initiate switch during timing resets the time delay. Loss of input voltage resets the time delay and output.

Features & Benefits

FEATURES	BENEFITS
DIP switch timing adjustment	Provides setting accuracy of +/-2%
User selectable time delay	Timing settings are switch selectable 0.1s - 102.3m in three ranges for added flexibility
1A steady, 10A inrush solid-state output	Provides 100 million operations in typical conditions.
Totally solid state and encapsulated	No moving parts to arc and wear out over time and encapsulated to protect against shock, vibration, and humidity.

Accessories



P1015-13 (AWG 10/12), **P1015-64** (AWG 14/16), **P1015-14** (AWG 18/22) **Female Quick Connect**
These 0.25 in. (6.35 mm) female terminals are constructed with an insulator barrel to provide strain relief.



P1015-18 Quick Connect to Screw Adapter
Screw adapter terminal designed for use with all modules with 0.25 in. (6.35 mm) male quick connect terminals.



C103PM (AL) DIN Rail
35 mm aluminum DIN rail available in a 36 in. (91.4 cm) length.



P1023-20 DIN Rail Adapter
Allows module to be mounted on a 35 mm DIN type rail with two #10 screws.

TDUB SERIES

Specifications

Time Delay

Range*	0.1 - 102.3s in 0.1s increments 1 - 1023s in 1s increments 0.1 - 102.3m in 0.1m increments
Repeat Accuracy	±0.5% or 20ms, whichever is greater
Setting Accuracy	±2% or 20ms, whichever is greater
Reset Time	≤ 150ms
Initiate Time	≤ 20ms
Time Delay vs. Temperature & Voltage	≤ ±5%

Input

Voltage/Tolerance	24 to 240VAC, 12 to 24VDC /±20%
AC Line Frequency/DC Ripple	50/60 Hz / ≤ 10%
Power Consumption	AC ≤ 2VA; DC ≤ 1W

Output

Type	Solid state
Form	NO, closed before and during timing
Rating	1A steady state, 10A inrush at 60°C
Voltage Drop	AC ≅ 2.5V @ 1A; DC ≅ 1V @ 1A
Off State Leakage Current	AC ≅ 5mA @ 230VAC; DC ≅ 1mA

Protection

Circuitry	Encapsulated
Dielectric Breakdown	≥ 2000V RMS terminals to mounting surface
Insulation Resistance	≥ 100 MΩ
Polarity	DC units are reverse polarity protected

Mechanical

Mounting	Surface mount with one #10 (M5 x 0.8) screw
Dimensions	H 50.8 mm (2"); W 50.8 mm (2"); D 30.7 mm (1.21")
Termination	0.25 in. (6.35 mm) male quick connect terminals

Environmental

Operating/Storage Temperature	-40° to 60°C / -40° to 85°C
Humidity	95% relative, non-condensing
Weight	≅ 2.4 oz (68 g)

Adjustment Switch Operation

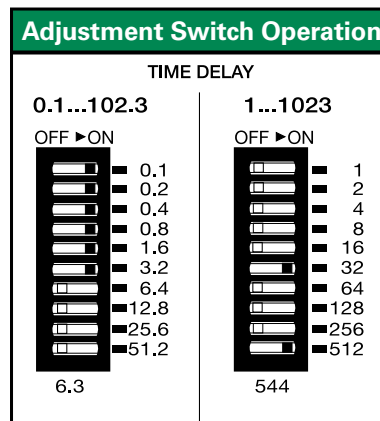

Add the value of switches in the ON position for the total time delay.

Function Diagram

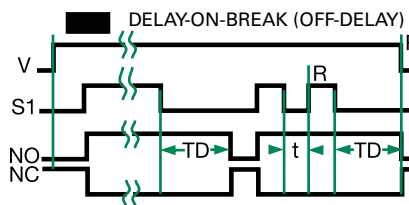

V = Voltage
S1 = Initiate Switch
NO = Normally Open Contact
NC = Normally Closed Contact
TD = Time Delay
t = Incomplete Time Delay
R = Reset
— = Undefined Time

*For CE approved applications, power must be removed from the unit when a switch position is changed.

THDB SERIES



Description

The THDB Series combines accurate timing circuitry with high power, solid-state switching. It can switch motors, lamps, and heaters directly without a contactor. You can reduce labor, component cost, and increase reliability with these small, easy-to-use, timers.

Operation (Delay-on-Break)

Input voltage must be applied before and during timing. Upon closure of the initiate switch, the output energizes. The time delay begins when the initiate switch is opened. The output remains energized during timing. At the end of the time delay, the output de-energizes. The output energizes if the initiate switch is closed when input voltage is applied.

Reset: Reclosing the initiate switch during timing resets the time delay. Loss of input voltage resets the time delay and output.

Wiring Diagram

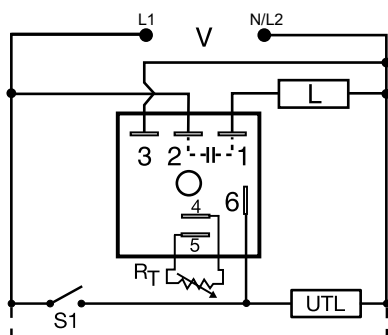

V = Voltage
UTL = Optional Untimed Load
L = Timed Load
S1 = Initiate Switch

R_T is used when external adjustment is ordered.

For dimensional drawing see: Appendix, page 512, Figure 19.

Ordering Information

MODEL	INPUT VOLTAGE	ADJUSTMENT	TIME DELAY	OUTPUT RATING
THDB421A	120VAC	External	1 - 100s	6A
THDB434C	120VAC	Onboard	1 - 100m	20A

If you don't find the part you need, call us for a custom product 800-843-8848

Features & Benefits

FEATURES	BENEFITS
Microcontroller based	Repeat accuracy +/- 0.5%, Factory calibration +/- 1%
High load currents up to 20A, 200A inrush	Allows direct operation of motors, lamps and heaters without a contactor
Totally solid state and encapsulated	No moving parts to arc and wear out over time and encapsulated to protect against shock, vibration, and humidity
Metalized mounting surface	Facilitates heat transfer in high current applications
Compact, low cost design	Allows flexibility for OEM applications and reduces labor and components costs

Accessories



P1004-95, P1004-95-X Versa-Pot

Panel mountable, industrial potentiometer recommended for remote time delay adjustment.



P0700-7 Versa-Knob

Designed for 0.25 in. (6.35 mm) shaft of Versa-Pot. Semi-gloss industrial black finish.



P1015-64 (AWG 14/16) Female Quick Connect

These 0.25 in. (6.35 mm) female terminals are constructed with an insulator barrel to provide strain relief.



P1015-18 Quick Connect to Screw Adapter

Screw adapter terminal designed for use with all modules with 0.25 in. (6.35 mm) male quick connect terminals.

THDB SERIES

External Resistance vs. Time Delay

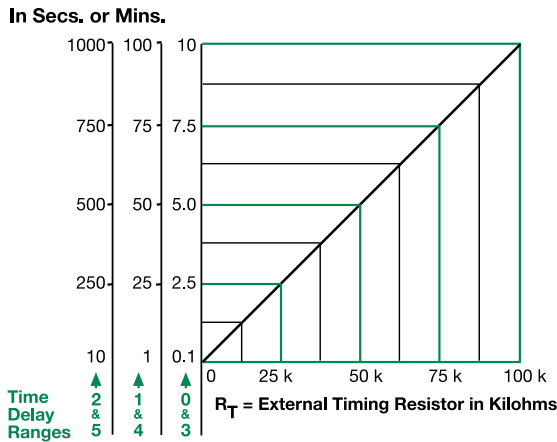

This chart applies to externally adjustable part numbers.
The time delay is adjustable over the time delay range selected by varying the resistance across the R_T terminals; as the resistance increases the tie delay increases.
When selecting an external R_T , add the tolerances of the timer and the R_T for the full time range adjustment.
Examples: 1 to 50 S adjustable time delay, select time delay range 1 and a 50 K ohm R_T . For 1 to 100 S use a 100 K ohm R_T .

Function Diagram

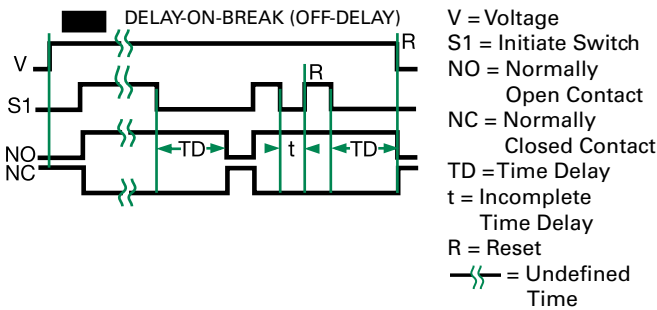

Specifications

Time Delay Range	0.1s - 1000ms in 6 adjustable ranges or fixed		
Repeat Accuracy Tolerance (Factory Calibration)	±0.5% or 20ms, whichever is greater		
Reset Time	≤ 150ms		
Initiate Time	≤ 20ms		
Time Delay vs Temp. & Voltage	≤ ±2%		
Input Voltage	24, 120, or 230VAC		
Tolerance	±20%		
AC Line Frequency	50/60 Hz		
Power Consumption	≤ 2VA		
Output Type	Solid state		
Form	NO, closed before & during timing		
Maximum Load Current	Output	Steady State	Inrush**
	A	6A	60A
	B	10A	100A
	C	20A	200A
Voltage Drop	≈ 2.5V @ rated current		
Off State Leakage Current	≈ 5mA @ 230VAC		
Minimum Load Current	100mA		
Protection Circuitry	Encapsulated		
Dielectric Breakdown	≥ 2000V RMS terminals to mounting surface		
Insulation Resistance	≥ 100 MΩ		
Mechanical Mounting **	Surface mount with one #10 (M5 x 0.8) screw		
Dimensions	H 50.8 mm (2.0"); W 50.8 mm (2.0"); D 38.4 mm (1.51")		
Termination	0.25 in. (6.35 mm) male quick connect terminals		
Environmental Operating/Storage Temperature	-40° to 60°C / -40° to 85°C		
Humidity	95% relative, non-condensing		
Weight	≈ 3.9 oz (111 g)		

**Must be bolted to a metal surface using the included heat sink compound. The maximum surface temperature is 90°C. Inrush: Non-repetitive for 16ms.

TRB SERIES



*8-pin models UL listed when used in combination with P1011-6 socket only.



8-PIN



11-PIN

Description

The TRB Series combines an isolated, 10A electromechanical relay output with analog timing circuitry. False trigger of the TRB by a transient is unlikely because of the complete isolation of the circuit from the line prior to initiation. The initiate contact is common to one side of the line and may be utilized to operate other loads. Installation is easy due to the TRB's industry standard 8- or 11-pin plug-in base wiring.

Operation (Delay-on-Break)

Input voltage must be applied before and during timing. Upon closure of the initiate switch, the output relay energizes. The time delay begins when the initiate switch is opened (trailing edge triggered). The output remains energized during timing. At the end of the time delay, the output de-energizes. The output will energize if the initiate switch is closed when input voltage is applied.

Reset: Reclosing the initiate switch during timing resets the time delay. Loss of input voltage resets the time delay and output.

Wiring Diagram

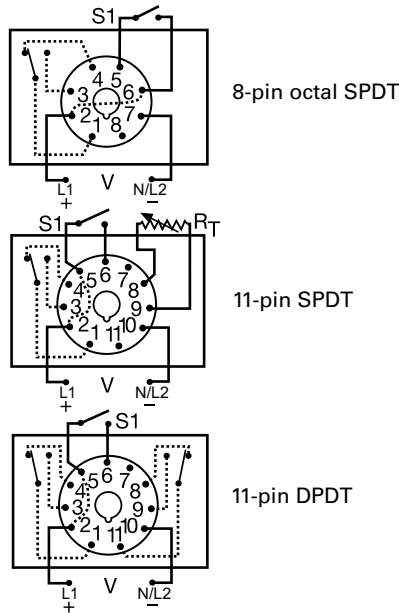

V = Voltage
S1 = Initiate Switch

Relay contacts are isolated.
R_T is used when external adjustment is ordered.

For dimensional drawing see: Appendix, page 512, Figure 24.

Features & Benefits

FEATURES	BENEFITS
Complete isolation of circuit from line	No false trip due to transients
Industry standard 8 or 11-pin connection	Provides easy installation and field replacement
Isolated, 10A, SPDT or DPDT output contacts	Allows control of loads for AC or DC voltages
Analog circuitry	Repeat accuracy + /- 2%

Accessories



P1004-XX, P1004-XX-X Versa-Pot
Panel mountable, industrial potentiometer recommended for remote time delay adjustment.



P0700-7 Versa-Knob
Designed for 0.25 in (6.35 mm) shaft of Versa-Pot. Semi-gloss industrial black finish.



BZ1 Front Panel Mount Kit
Provides an easy method of through-the-panel mounting of 8- or 11-pin plug-in timers, flashers, and other controls.

Ordering Information

MODEL	INPUT VOLTAGE	ADJUSTMENT	OUTPUT FORM	TIME TOLERANCE	TIME DELAY
TRB120A2Y30	120VAC	Onboard	Octal, SPDT (AC only)	+ /- 10%	1 - 30s
TRB120A3X600	120VAC	Lock shaft	Octal, SPDT (AC only)	+ /- 20%	7 - 600s
TRB120A4Y120	120VAC	Onboard	11-pin, DPDT	+ /- 10%	2 - 120s
TRB24D10Y10	24VDC/28VDC	Fixed	11-pin, DPDT	+ /- 10%	10s

If you don't find the part you need, call us for a custom product 800-843-8848

TRB SERIES

Accessories



NDS-8 Octal 8-pin Socket
8-pin 35mm DIN rail or surface mount. Surface mounted with two #6 screws or snaps onto a 35 mm DIN rail. Uses PSC8 hold-down clips.



NDS-11 11-pin Socket
11-pin 35mm DIN rail or surface mount. Surface mounted with two #6 screws or snaps onto a 35 mm DIN rail. Uses PSC11 hold-down clips.



P1011-6 Octal Socket for UL listing*
8-pin surface mount socket with binder head screw terminals. Rated 10A @ 600VAC.

Selection Guides

VALUE	PART NUMBER
1M ohm	P1004-16
1.5M ohm	P1004-15
2M ohm	P1004-14
3M ohm	P1004-12
5M ohm	P1004-13
1M ohm	P1004-16-X
1.5M ohm	P1004-15-X
2M ohm	P1004-14-X
3M ohm	P1004-12-X
5M ohm	P1004-13-X

Time Delay*	
Range	R_T
Seconds	Megohm
0.05...1	1.0
0.05...2	2.0
0.05...3	3.0
0.1...5	5.0
0.1...10	3.0
1...30	1.5
1...60	3.0
2...120	2.0
2...180	3.0
7...240	1.5
7...300	2.0
7...360	2.0
7...420	3.0
7...480	3.0
7...600	5.0

* When selecting an external R_T add at least 15...30% for tolerance of unit and the R_T .

Specifications

Time Delay

Type Analog circuitry
Range 50ms - 10m in 15 adjustable ranges or fixed
Repeat Accuracy $\pm 2\%$ or 20ms, whichever is greater
Fixed Time Tolerance & Setting Accuracy $\pm 5, 10, \text{ or } 20\%$
Initiate Time $\leq 70\text{ms}$
Reset Time $\leq 75\text{ms}$
Recycle Time $\leq 250\text{ms}$
Time Delay vs Temp. & Voltage $\leq \pm 10\%$
Input Voltage 24/28 or 110VDC; 24, 120, or 230VAC (DC voltages on DPDT output models only)

Tolerance

24VDC/AC -15% - 20%
10 to 230VAC/DC -20% - 10%
AC Line Frequency 50/60 Hz
Power Consumption $\leq 3.25\text{W}$

Output

Type Electromechanical relay
Form Isolated SPDT or DPDT
Rating 10A resistive @ 120/240VAC & 28VDC; 1/3 hp @ 120/240VAC

Life

Protection Mechanical - 1×10^7 ; Electrical - 1×10^6
Insulation Resistance $\geq 100\text{M}\Omega$
Isolation Voltage $\geq 1500\text{V RMS}$ between input to output
Polarity DC units are reverse polarity protected

Mechanical

Mounting Plug-in socket
Dimensions **H** 91.6 mm (3.62"); **W** 60.7 mm (2.39"); **D** 45.2 mm (1.78")

Termination

Environmental Octal 8-pin plug-in or 11-pin plug-in

Operating/Storage

Temperature -20° to 65°C / -30° to 85°C
Weight $\approx 6\text{ oz (170 g)}$

Function Diagram

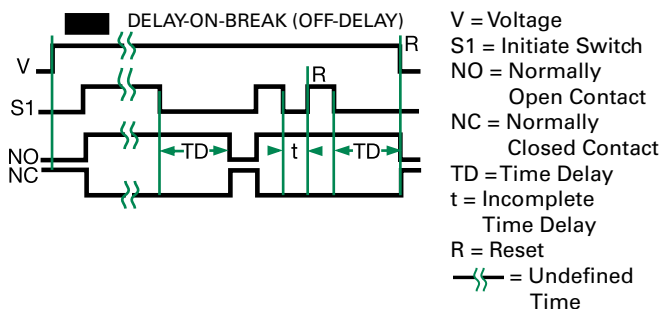

TSB SERIES



Description

The TSB Series is a totally solid-state, delay-on-break timing module. The TSB Series is available with a fixed, external, or onboard adjustable time delay. Time Delays from 0.05 to 600 seconds, in 4 standard ranges, cover over 90% of all OEM and commercial appliance timing applications. The repeat accuracy is $\pm 2\%$. Operating voltages of 24, 120, or 230VAC are available. The TSB's 1A steady state, 10A rated, solid-state output is perfect for direct control of solenoids, contactors, relays, lamps, buzzers, and small heaters. The TSB Series can be surface mounted with a single screw, or snapped on a 35 mm DIN rail using the P1023-20 adaptor.

Operation (Delay-on-Break)

Input voltage must be applied before and during timing. Upon closure of the initiate switch, the output energizes. The time delay begins when the initiate switch opens. The output remains energized during timing. At the end of the time delay, the output de-energizes. The output will energize if the initiate switch is closed when input voltage is applied.

Reset: Reclosing the initiate switch during timing resets the time delay. Loss of input voltage resets the output and the time delay.

Wiring Diagram

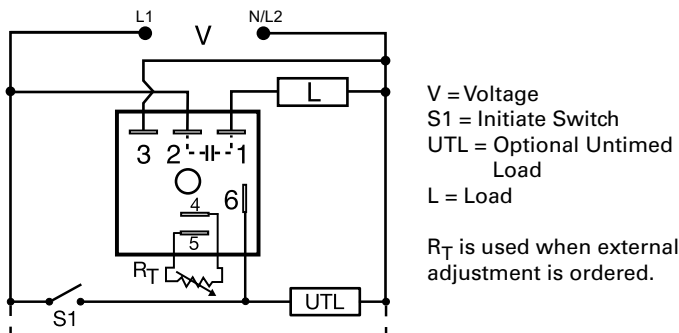

For dimensional drawing see: Appendix, page 512, Figure 16.

Features & Benefits

FEATURES	BENEFITS
Analog circuitry	Repeat accuracy $\pm 2\%$, Factory calibration $\pm 5\%$
Totally solid state and encapsulated	No moving parts to arc and wear out over time and encapsulated to protect against shock, vibration, and humidity
Wide time delay range	Meets almost all OEM and commercial appliance timing applications
1A steady, 10A inrush solid state output	Provides 100 million operations in typical conditions

Accessories



P1004-95, P1004-95-X Versa-Pot

Panel mountable, industrial potentiometer recommended for remote time delay adjustment.



P1023-6 Mounting bracket

The 90° orientation of mounting slots makes installation/removal of modules quick and easy.

Ordering Information

MODEL	INPUT VOLTAGE	ADJUSTMENT	TIME DELAY	MODEL	INPUT VOLTAGE	ADJUSTMENT	TIME DELAY
TSB2190	24VAC	Fixed	90s	TSB434	120VAC	Onboard	5 - 600s
TSB222	24VAC	External	0.5 - 60s	TSB632	230VAC	Onboard	0.5 - 60s
TSB41300	120VAC	Fixed	300s	TSB634	230VAC	Onboard	5 - 600s
TSB422	120VAC	External	0.5 - 60s				

If you don't find the part you need, call us for a custom product 800-843-8848

TSB SERIES

Accessories



P0700-7 Versa-Knob
Designed for 0.25 in (6.35 mm) shaft of Versa-Pot. Semi-gloss industrial black finish.



P1015-64 (AWG 14/16) Female Quick Connect
These 0.25 in. (6.35 mm) female terminals are constructed with an insulator barrel to provide strain relief.



P1015-18 Quick Connect to Screw Adapter
Screw adapter terminal designed for use with all modules with 0.25 in. (6.35 mm) male quick connect terminals.



C103PM (AL) DIN Rail
35 mm aluminum DIN rail available in a 36 in. (91.4 cm) length.



P1023-20 DIN Rail Adapter
Allows module to be mounted on a 35 mm DIN type rail with two #10 screws.

Selection Guide

RT Selection Chart				
Desired Time Delay*				RT
Seconds				
1	2	3	4	Kohms
0.05	0.5	2	5	0
0.3	6	20	60	10
0.6	12	38	120	20
0.9	18	55	180	30
1.2	24	73	240	40
1.5	30	90	300	50
1.8	36	108	360	60
2.1	42	126	420	70
2.4	48	144	480	80
2.7	54	162	540	90
3.0	60	180	600	100

* When selecting an external RT add at least 20% for tolerance of unit and the RT.

Function Diagram

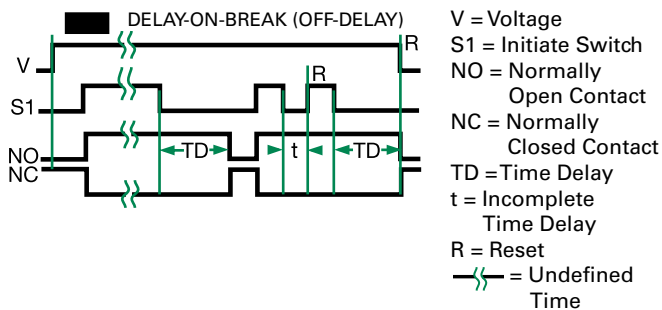

Specifications

Time Delay

Range 0.05s - 600s in 4 adjustable ranges or fixed
Repeat Accuracy ±2% or 20ms, whichever is greater

Tolerance

Factory Calibration ≤ ±5%

Time Delay vs Temp. & Voltage

≤ ±10%

Reset Time

≤ 150ms

Input

Voltage 24, 120, or 230VAC

Tolerance

±20%

AC Line Frequency

50/60 Hz

Power Consumption

≤ 2VA

Output

Type

Solid state

Form

NO, closed before & during timing

Maximum Load Current

1A steady state, 10A inrush at 60°C

Off State Leakage Current

≅ 5mA @ 230VAC

Voltage Drop

≅ 2.5V @ 1A

Protection

Circuitry

Encapsulated

Dielectric Breakdown

≥ 2000V RMS terminals to mounting surface

Insulation Resistance

≥ 100 MΩ

Mechanical

Mounting

Surface mount with one #10 (M5 x 0.8) screw

Dimensions

H 50.8 mm (2.0"); **W** 50.8 mm (2.0");

D 30.7 mm (1.21")

0.25 in. (6.35 mm) male quick connect terminals

Termination

Environmental

Operating/Storage

Temperature

-40° to 75°C / -40° to 85°C

Humidity

95% relative, non-condensing

Weight

≅ 2.4 oz (68 g)

12

TIME DELAY RELAYS

TSDB SERIES

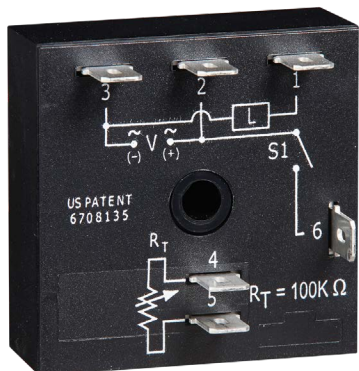

Wiring Diagram

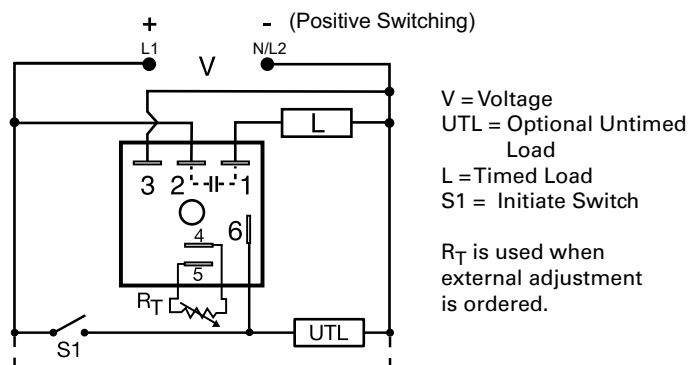

For dimensional drawing see: Appendix, page 512, Figure 16.

Ordering Information

MODEL	INPUT VOLTAGE	ADJUSTMENT	TIME DELAY	SWITCHING MODE
TSDB320P	24VDC	External	0.1 - 10s	Positive
TSDB421	120VAC	External	1 - 100s	n/a
TSDB431	120VAC	Onboard	1 - 100s	n/a

If you don't find the part you need, call us for a custom product 800-843-8848

Description

The TSDB Series is designed for more demanding commercial and industrial applications where small size, and accurate performance are required. The factory calibration for fixed time delays is within 1% of the target time delay. The repeat accuracy, under stable conditions, is 0.5% of the time delay.

The TSDB Series is rated to operate over an extended temperature range. Time delays of 0.1 seconds to 1000 minutes are available. The output is rated 1A steady and 10A inrush. The modules are totally solid state and encapsulated to protect the electronic circuitry.

Operation (Delay-on-Break)

Input voltage must be applied before and during timing. Upon closure of the initiate switch, the output energizes. The time delay begins when the initiate switch is opened. The output remains energized during timing. At the end of the time delay, the output de-energizes. The output will energize if the initiate switch is closed when input voltage is applied.

Reset: Reclosing the initiate switch during timing resets the time delay. Loss of input voltage resets the time delay and output.

Features & Benefits

FEATURES	BENEFITS
Microcontroller based	Repeat accuracy +/- 0.5%, Factory calibration +/- 1%
Compact design	Allows flexibility for OEM applications
1A Steady, 10A inrush solid-state output	Provides 100 million operations in typical conditions.
Totally solid state and encapsulated	No moving parts to arc and wear out over time and encapsulated to protect against shock, vibration, and humidity
Wide temperature range: -40° to 75°C	Reliable in demanding commercial and industrial applications

Accessories



P1004-13, P1004-13-X Versa-Pot
Panel mountable, industrial potentiometer recommended for remote time delay adjustment.



P1023-6 Mounting bracket
The 90° orientation of mounting slots makes installation/removal of modules quick and easy.



P0700-7 Versa-Knob
Designed for 0.25 in. (6.35 mm) shaft of Versa-Pot. Semi-gloss industrial black finish.



P1015-64 (AWG 14/16) Female Quick Connect
These 0.25 in. (6.35 mm) female terminals are constructed with an insulator barrel to provide strain relief.

TSDB SERIES

Accessories



P1015-18 Quick Connect to Screw Adapter
Screw adapter terminal designed for use with all modules with 0.25 in. (6.35 mm) male quick connect terminals.



C103PM (AL) DIN Rail
35 mm aluminum DIN rail available in a 36 in. (91.4 cm) length.



P1023-20 DIN Rail Adapter
Allows module to be mounted on a 35 mm DIN type rail with two #10 screws.

External Resistance vs. Time Delay

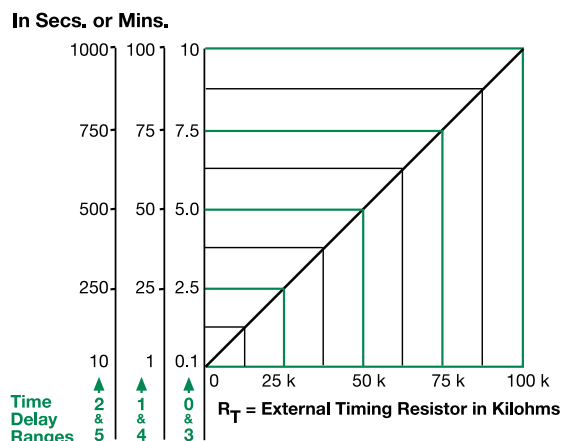

This chart applies to externally adjustable part numbers.
The time delay is adjustable over the time delay range selected by varying the resistance across the R_T terminals; as the resistance increases the tie delay increases.

When selecting an external R_T , add the tolerances of the timer and the R_T for the full time range adjustment.

Examples: 1 to 50 S adjustable time delay, select time delay range 1 and a 50 K ohm R_T . For 1 to 100 S use a 100 K ohm R_T .

Function Diagram

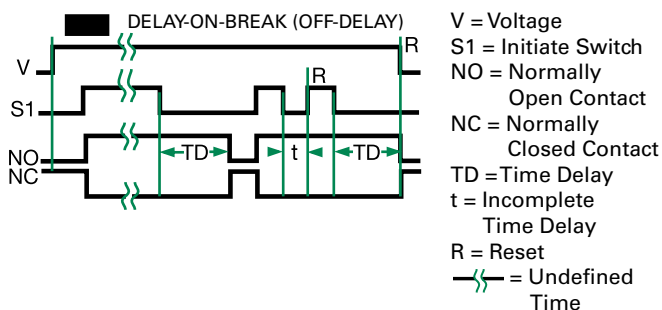

Specifications

Time Delay Range	0.1s - 1000m in 6 adjustable ranges or fixed
Repeat Accuracy	±0.5 % or 20ms, whichever is greater
Tolerance (Factory Calibration)	≤ ±1%
Reset Time	≤ 150ms
Initiate Time	≤ 20ms
Time Delay vs Temp. & Voltage	≤ ±2%
Input Voltage	12 or 24VDC; 24, 120, or 230VAC
Tolerance	±15%
Power Consumption	AC ≤ 2VA; DC ≤ 1W
AC Line Frequency/DC Ripple	50/60 Hz / ≤ 10 %
Output Type	Solid state
Form	NO, closed before & during timing
Maximum Load Current	1A steady state, 10A inrush at 60°C
Off State Leakage Current	≈ 5mA @ 230VAC; DC ≈ 1mA
Voltage Drop	AC ≈ 2.5V @ 1A; DC ≈ 1V @ 1A
DC Operation	Positive or negative switching
Protection	
Circuitry	Encapsulated
Dielectric Breakdown	≥ 2000V RMS terminals to mounting surface
Insulation Resistance	≥ 100 MΩ
Polarity	DC units are reverse polarity protected
Mechanical	
Mounting	Surface mount with one #10 (M5 x 0.8) screw
Dimensions	H 50.8 mm (2.0"); W 50.8 mm (2.0"); D 30.7 mm (1.21")
Termination	0.25 in. (6.35 mm) male quick connect terminals
Environmental	
Operating/Storage Temperature	-40° to 75°F / -40° to 85°F
Humidity	95% relative, non-condensing
Weight	≈ 2.4 oz (68 g)

HRDS SERIES

Single Shot Timer



Wiring Diagram

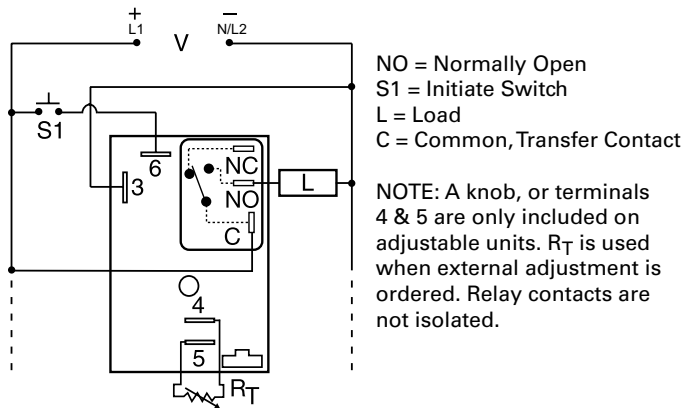

For dimensional drawing see: Appendix, page 512, Figure 17.

Ordering Information

MODEL	INPUT VOLTAGE	ADJUSTMENT	TIME DELAY
HRDS120	12VDC	Onboard	0.1 - 10s
HRDS313M	24VDC	Fixed	3m
HRDS321	24VDC	Onboard	1 - 100s
HRDS421	120VAC	Onboard	1 - 100s
HRDS430	120VAC	External	0.1 - 10s

If you don't find the part you need, call us for a custom product 800-843-8848

Description

The HRDS Series combines an electromechanical relay output with microcontroller timing circuitry. It offers 12 to 230V operation in five options and factory fixed, onboard or external adjustable time delays with a repeat accuracy of $\pm 0.5\%$. The output contact rating allows for direct operation of heavy loads, such as compressors, pumps, blower motors, heaters, etc. This series is ideal for OEM applications where cost is a factor.

Operation (Single Shot)

Input voltage must be applied before and during timing. Upon momentary or maintained closure of the initiate switch, the output relay energizes for a measured interval of time. At the end of the delay, the output de-energizes. Opening or reclosing the initiate switch during timing has no effect on the time delay. The output will energize if the initiate switch is closed when input voltage is applied.

Reset: Reset occurs when the time delay is complete and the initiate switch is opened. Loss of input voltage resets the time delay and output.

Features & Benefits

FEATURES	BENEFITS
Microcontroller based	Repeat Accuracy $\pm 0.5\%$
Compact, low cost design	Allows flexibility for OEM applications
Isolated, 30A, SPDT, NO output contacts	Allows direct operation of heavy loads: compressors, pumps, blower motors, heaters.
Encapsulated	Protects against shock, vibration, and humidity

Accessories



P1004-95, P1004-95-X Versa-Pot
Panel mountable, industrial potentiometer recommended for remote time delay adjustment.



P1023-6 Mounting bracket
The 90° orientation of mounting slots makes installation/removal of modules quick and easy.



P0700-7 Versa-Knob
Designed for 0.25 in. (6.35 mm) shaft of Versa-Pot. Semi-gloss industrial black finish.



P1015-13 (AWG 10/12), P1015-64 (AWG 14/16) Female Quick Connect
These 0.25 in. (6.35 mm) female terminals are constructed with an insulator barrel to provide strain relief.



P1015-18 Quick Connect to Screw Adapter
Screw adapter terminal designed for use with all modules with 0.25 in. (6.35 mm) male quick connect terminals.

HRDS SERIES

Accessories



C103PM (AL) DIN Rail
35 mm aluminum DIN rail available in a 36 in. (91.4 cm) length.



P1023-20 DIN Rail Adapter
Allows module to be mounted on a 35 mm DIN type rail with two #10 screws.

External Resistance vs. Time Delay

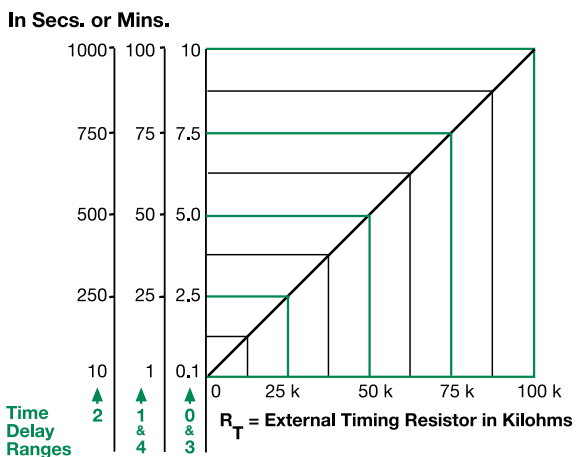

This chart applies to externally adjustable part numbers.

The time delay is adjustable over the time delay range selected by varying the resistance across the R_T terminals; as the resistance increases the time delay increases.

When selecting an external R_T , add the tolerances of the timer and the R_T for the full time range adjustment.

Examples: 1 to 50 S adjustable time delay, select time delay range 1 and a 50 K ohm R_T . For 1 to 100 S use a 100 K ohm R_T .

Function Diagram

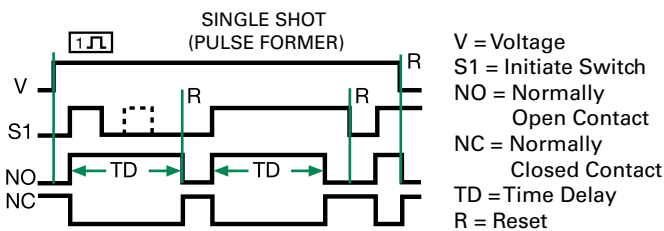

Specifications

Time Delay

Type	Microcontroller circuitry
Range	0.1s - 100m in 5 adjustable ranges or fixed
Repeat Accuracy	±0.5% or 20 ms, whichever is greater
Tolerance	
(Factory Calibration)	±1%, ±5%
Reset Time	≤ 150ms
Initiate Time	≤ 20ms
Time Delay vs Temp. & Voltage	±2%

Input

Voltage	12 or 24VDC; 24, 120, or 230VAC
Tolerance	
12VDC & 24VDC	-15% - 20%
24 to 230VAC	-20% - 10%
AC Line Frequency	50/60 Hz
Power Consumption	AC ≤ 4VA; DC ≤ 2W

Output

Type	Electromechanical relay	
Form	SPDT, non-isolated	
Ratings	SPDT-NO	SPDT-NC
General Purpose	125/240VAC	30A
Resistive	125/240VAC	30A
	28VDC	20A
Motor Load	125VAC	1 hp*
	240VAC	2 hp**
		15A
		15A
		10A
		1/4 hp**
		1 hp**

Life

Mechanical - 1 x 10⁶;
Electrical - 1 x 10⁵, *3 x 10⁴, **6,000

Protection

Surge	IEEE C62.41-1991 Level A
Circuitry	Encapsulated
Dielectric Breakdown	≥ 2000V RMS terminals to mounting surface
Insulation Resistance	≥ 100 MΩ
Polarity	DC units are reverse polarity protected

Mechanical

Mounting	Surface mount with one #10 (M5 x 0.8) screw
Dimensions	H 76.7 mm (3"); W 51.3 mm (2"); D 38.1 mm (1.5")
Termination	0.25 in. (6.35 mm) male quick connect terminals

Environmental

Operating/Storage Temperature	-40° to 60°C/-40° to 85°C
Humidity	95% relative, non-condensing
Weight	≈ 3.9 oz (111 g)

HSPZA22SL



Description

The HSPZA22SL is a factory programmed module available in any 1 of 13 standard functions. The HSPZA22SL offers dual switch adjustable timer or counter functions. Switch adjustment allows accurate selection of the time delay or number of counts the first time and every time. The 1A steady, 10A inrush rated solid-state output provides 100 million operations, typical. Its microcontroller timing circuit provides excellent repeat accuracy and stability. Encapsulation protects against shock, vibration, and humidity. The HSPZA22SL is a cost effective approach for OEM applications that require small size, solid state reliability, and accurate switch adjustment.

Operation (Single Shot Lockout)

Upon application of input voltage and momentary or maintained closure of S1, the output relay energizes and TD1 single shot time delay begins. The output relay de-energizes at the end of TD1 and the TD2 lockout time delay begins. During TD2 (and TD1) closing switch S1 has no effect on the operation. After TD2 is complete, closing S1 starts another operation. If S1 is closed when input voltage is applied, the output energizes and the TD1 time delay begins.

Reset: Removing input voltage resets the time delays and the output and returns the cycle to the first delay.

Wiring Diagram

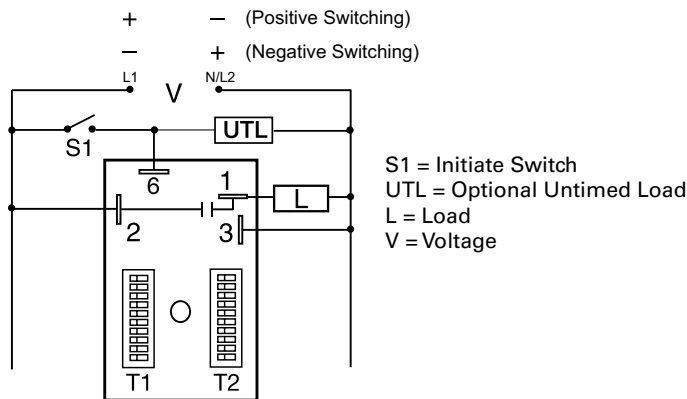

For dimensional drawing see: Appendix, page 512, Figure 18.

Features & Benefits

FEATURES	BENEFITS
Microcontroller based	Repeat Accuracy +/- 0.1%
User selectable time delay	Timing settings are switch selectable 0.1s - 1023h in a dual switch timer function for added flexibility
1A steady, 10A inrush solid-state output	Provides 100 million operations in typical conditions.
Totally solid-state and encapsulated	No moving parts to arc and wear out over time and encapsulated to protect against shock, vibration, and humidity

Accessories



P1015-18 Quick Connect to Screw Adapter
Screw adapter terminal designed for use with all modules with 0.25 in. (6.35 mm) male quick connect terminals.



C103PM (AL) DIN Rail
35 mm aluminum DIN rail available in a 36 in. (91.4 cm) length.



P1023-20 DIN Rail Adapter
Allows module to be mounted on a 35 mm DIN type rail with two #10 screws.

HSPZA22SL

Switch Adjustment

Adjustment Switch Operation			
TIME DELAY		TIME DELAY and COUNTER	
0.1...102.3	1...512	1...1023	1...165
OFF ▶ ON	OFF ▶ ON	OFF ▶ ON	OFF ▶ ON
0.1 0.2 0.4 0.8 1.6 3.2 6.4 12.8 25.6 51.2	1 2 4 8 16 32 64 128 256 M	1 2 4 8 16 32 64 128 256 512	1 2 3 4 5 10 20 30 40 50
6.3	300 s Delay	544	57 counts

Function Diagrams

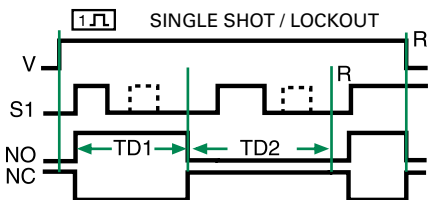

V = Voltage
S1 = Initiate Switch
NO = Normally Open Contact
NC = Normally Closed Contact
TD1, TD2 = Time Delay
R = Reset

Specifications

Time Delay

Type

Microcontroller circuitry

Range

1-1023s, m or h in 1s, m or h increments

Repeat Accuracy

±0.1% or 20ms, whichever is greater

Setting Accuracy

≤ ±1% or 20ms, whichever is greater

Reset Time

≤ 150ms

Initiate Time

≤ 20ms

Time Delay vs Temp.

≤ ±2%

& Voltage

≤ ±2%

Count Range

1 - 1023 in 2 ranges

Count Rate

≤ 25 counts per second

Input

Voltage

24 to 240VAC

Tolerance

≤ ±15%

AC Line Frequency/

DC Ripple

50/60Hz / ≤ 10%

Power Consumption

AC ≤ 2VA; DC ≤ 1W

Output

Type

Solid-state output

Rating

1A steady, 10A inrush for 16ms

Voltage Drop

AC ≈ 2.5V @ 1A; DC ≈ 1V @ 1A

OFF State Leakage Current

AC ≈ 5mA @ 240VAC; DC ≈ 1mA

Counter Output

Output pulse width: 300ms ±20%

Protection

Circuitry

Encapsulated

Dielectric Breakdown

≥ 2000V RMS terminals to mounting surface

Insulation Resistance

≥ 100 MΩ

Polarity

DC units are reverse polarity protected

Mechanical

Mounting

Surface mount with one #10 (M5 x 0.8) screw

Dimensions

H 76.2 mm (3.0"); **W** 50.8 mm (2.0");

D 38.1 mm (1.5")

0.25 in. (6.35 mm) male quick connects

Termination

Environmental

Operating/Storage

Temperature

-40° to 60°C / -40° to 85°C

Humidity

95% relative, non-condensing

Weight

≈ 3.9 oz (111 g)

KRDS SERIES

Single Shot



Wiring Diagram

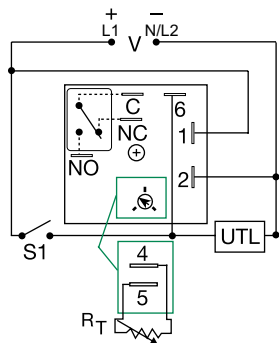

V = Voltage
S1 = Initiate Switch
C = Common, Transfer Contact
NO = Normally Open
NC = Normally Closed
UTL = Untimed Load

R_T is used when external adjustment is ordered. A knob is supplied for adjustable units. The untimed load is optional. Relay contacts are isolated.

For dimensional drawing see: Appendix, page 512, Figure 16.

Ordering Information

MODEL	INPUT VOLTAGE	ADJUSTMENT	TIME DELAY
KRDS1135M	12VDC	Fixed	35m
KRDS120	12VDC	Onboard	0.1 - 10s
KRDS221	24VAC/DC	Onboard	1 - 100s
KRDS420	120VAC	Onboard	0.1 - 10s
KRDS421	120VAC	Onboard	1 - 100s
KRDS424	120VAC	Onboard	1 - 100m
KRDS430	120VAC	External	0.1 - 10s

If desired part number is not listed, please call us to see if it is technically possible to build.

Description

The KRDS Series is a compact time delay relay measuring only 2 in. (50.8 mm) square. Its microcontroller timing circuit provides excellent repeat accuracy and stability. Encapsulation protects against shock, vibration, and humidity. The KRDS Series is a cost effective approach for OEM applications that require small size, isolation, reliability, and long life.

Operation (Single Shot)

Input voltage must be applied before and during timing. Upon momentary or maintained closure of the initiate switch, the output relay energizes for a measured interval of time. At the end of the delay, the output de-energizes. Opening or reclosing the initiate switch during timing has no effect on the time delay. The output will energize if the initiate switch is closed when input voltage is applied.

Reset: Reset occurs when the time delay is complete and the initiate switch is opened. Loss of input voltage resets the time delay and output.

Features & Benefits

FEATURES	BENEFITS
Compact, low cost design measuring 2 in. (50.8mm) square	Allows flexibility for OEM applications
Microcontroller based	Repeat Accuracy + / - 0.5%, Factory calibration + / - 5%
Isolated, 10A, SPDT output contacts	Allows control of loads for AC or DC voltages
Encapsulated	To protect against shock, vibration, and humidity

Accessories



P1004-95, P1004-95-X Versa-Pot

Panel mountable, industrial potentiometer recommended for remote time delay adjustment.



P1023-6 Mounting bracket

The 90° orientation of mounting slots makes installation/removal of modules quick and easy.



P0700-7 Versa-Knob

Designed for 0.25 in. (6.35 mm) shaft of Versa-Pot. Semi-gloss industrial black finish.



P1015-64 (AWG 14/16)

Female Quick Connect

These 0.25 in. (6.35 mm) female terminals are constructed with an insulator barrel to provide strain relief.



P1015-18 Quick Connect to Screw Adapter

Screw adapter terminal designed for use with all modules with 0.25 in. (6.35 mm) male quick connect terminals.

KRDS SERIES

Accessories



C103PM (AL) DIN Rail
35 mm aluminum DIN rail available in a 36 in. (91.4 cm) length.



P1023-20 DIN Rail Adapter
Allows module to be mounted on a 35 mm DIN type rail with two #10 screws.

External Resistance vs. Time Delay

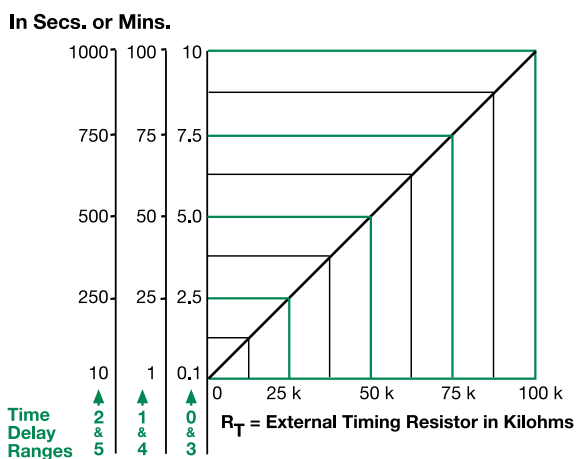

This chart applies to externally adjustable part numbers.
The time delay is adjustable over the time delay range selected by varying the resistance across the R_T terminals; as the resistance increases the time delay increases.

When selecting an external R_T , add the tolerances of the timer and the R_T for the full time range adjustment.

Examples: 1 to 50 S adjustable time delay, select time delay range 1 and a 50 K ohm R_T . For 1 to 100 S use a 100 K ohm R_T .

Output Current/Ambient Temperature

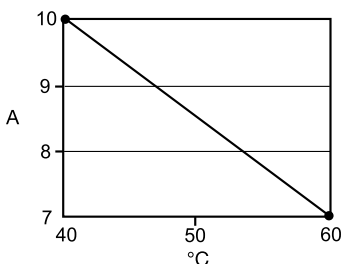

Specifications

Time Delay

Type	Microcontroller with watchdog circuitry
Range	0.1s - 1000m in 6 adjustable ranges or fixed
Repeat Accuracy	±0.5% or 20ms, whichever is greater
Tolerance	
(Factory Calibration)	≤ ±5%
Reset Time	≤ 150ms
Initiate Time	≤ 40ms
Time Delay vs Temp. & Voltage	≤ ±5%

Input

Voltage	12, 24 or 110VDC; 24, 120 or 230VAC
Tolerance	
12VDC & 24VDC/AC	-15% - 20%
110VDC, 120VAC or 230VAC	-20% - 10%
AC Line Frequency/DC Ripple	50/60 Hz / ≤ 10%
Power Consumption	AC ≤ 2VA; DC ≤ 2W

Output

Type	Isolated relay contacts
Form	SPDT
Rating (at 40°C)	10A resistive @ 125VAC; 5A resistive @ 230VAC & 28VDC; 1/4 hp @ 125VAC
Life (Operations)	Mechanical - 1×10^7 ; Electrical - 1×10^5

Protection

Circuitry	Encapsulated
Isolation Voltage	≥ 1500V RMS input to output
Insulation Resistance	≥ 100 MΩ
Polarity	DC units are reverse polarity protected

Mechanical

Mounting	Surface mount with one #10 (M5 x 0.8) screw
Dimensions	H 50.8 mm (2.0"); W 50.8 mm (2.0"); D 30.7 mm (1.21")
Termination	0.25 in. (6.35 mm) male quick connect terminals

Environmental

Operating/Storage Temperature	-40° to 60°C/-40° to 85°C
Humidity	95% relative, non-condensing
Weight	≈ 2.6 oz (74 g)

Function Diagram

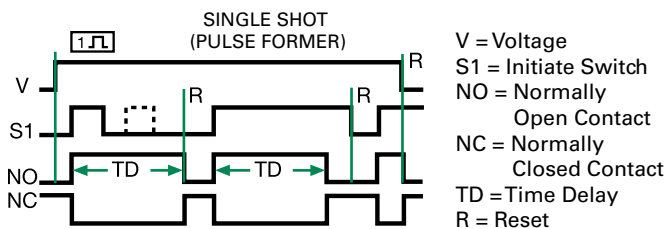

KSDS SERIES



Wiring Diagram

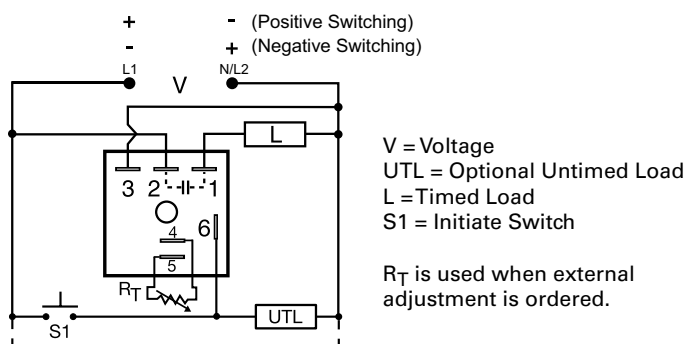

For dimensional drawing see: Appendix, page 512, Figure 16.

Ordering Information

MODEL	INPUT VOLTAGE	ADJUSTMENT	TIME DELAY	SWITCHING MODE
KSDS1115SP	12VDC	Fixed	15s	Positive
KSDS230	24VAC	Onboard	0.1 - 10s	n/a
KSDS320P	24VAC	External	0.1 - 10s	Positive
KSDS415M	120VAC	Fixed	5m	n/a
KSDS420	120VAC	External	0.1 - 10s	n/a

If you don't find the part you need, call us for a custom product 800-843-8848

Description

The KSDS Series is ideal for applications that require momentary start interval timing including dispensing, exposure timing, or pulse shaping. This series is available for both AC and DC voltages. This series is designed for general purpose commercial and industrial applications where a small, cost effective, reliable solid-state timer is required. The factory calibration for fixed time delays is within 5% of the target time delay. The repeat accuracy, under stable conditions, is 0.5% of the selected time delay. Time delays of 0.1 seconds to 1000 minutes are available in 6 ranges. The output is rated 1A steady and 10A inrush. The modules are totally solid state and encapsulated to protect the electronic circuitry.

Operation (Single Shot)

Input voltage must be applied before and during timing. Upon momentary or maintained closure of the initiate switch (leading edge triggered), the output energizes for a measured interval of time. At the end of the delay, the output de-energizes. Opening or reclosing the initiate switch during timing has no effect on the time delay. The output will not energize if the initiate switch is closed when input voltage is applied.

Reset: Reset occurs when the time delay is complete and the initiate switch is opened. Loss of input voltage resets the time delay and output.

Features & Benefits

FEATURES	BENEFITS
Microcontroller based	Repeat Accuracy +/- 0.5%, Factory calibration +/- 5%
1A Steady, 10A inrush solid-state output	Provides 100 million operations in typical conditions.
Totally solid state and encapsulated	No moving parts to arc and wear out over time and encapsulated to protect against shock, vibration, and humidity
Compact, low cost design	Allows flexibility for OEM applications

Accessories



P1004-95, P1004-95-X Versa-Pot

Panel mountable, industrial potentiometer recommended for remote time delay adjustment.



P1023-6 Mounting bracket

The 90° orientation of mounting slots makes installation/removal of modules quick and easy.



P0700-7 Versa-Knob

Designed for 0.25 in (6.35 mm) shaft of Versa-Pot. Semi-gloss industrial black finish.



P1015-13 (AWG 10/12), P1015-64 (AWG 14/16) Female Quick Connect

These 0.25 in. (6.35 mm) female terminals are constructed with an insulator barrel to provide strain relief.

KSIDS SERIES

Accessories



P1015-18 Quick Connect to Screw Adapter
Screw adapter terminal designed for use with all modules with 0.25 in. (6.35 mm) male quick connect terminals.



C103PM (AL) DIN Rail
35 mm aluminum DIN rail available in a 36 in. (91.4 cm) length.



P1023-20 DIN Rail Adapter
Allows module to be mounted on a 35 mm DIN type rail with two #10 screws.

External Resistance vs. Time Delay

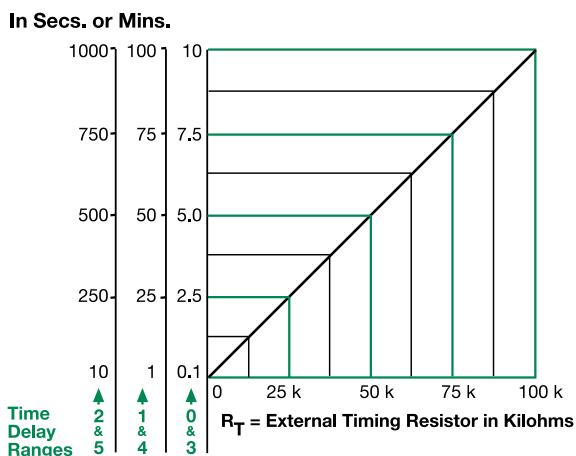

This chart applies to externally adjustable part numbers.
The time delay is adjustable over the time delay range selected by varying the resistance across the R_T terminals; as the resistance increases the time delay increases.

When selecting an external R_T , add the tolerances of the timer and the R_T for the full time range adjustment.

Examples: 1 to 50 S adjustable time delay, select time delay range 1 and a 50 K ohm R_T . For 1 to 100 S use a 100 K ohm R_T .

Specifications

Time Delay Range	0.1s - 1000m in 6 adjustable ranges or fixed
Repeat Accuracy	±0.5 % or 20ms, whichever is greater
Tolerance (Factory Calibration)	≤ ±5%
Reset Time	≤ 150ms
Initiate Time	≤ 20ms
Time Delay vs Temp. & Voltage	≤ ±10%
Input Voltage	12 or 24VDC; 24, 120, or 230VAC
Voltage Tolerance	±20%
AC Line Frequency/DC Ripple	50/60 Hz / ≤ 10 %
Power Consumption	AC ≤ 2VA; DC ≤ 1W
Output Type	Solid state
Form	NO, closed during timing
Maximum Load Current	1A steady state, 10A inrush at 60°C
OFF State Leakage Current	AC ≅ 5mA @ 230VAC; DC ≅ 1mA
Voltage Drop	AC ≅ 2.5V @ 1A; DC ≅ 1V @ 1A
DC Operation	Positive or negative switching
Protection	
Circuitry	Encapsulated
Dielectric Breakdown	≥ 2000V RMS terminals to mounting surface
Insulation Resistance	≥ 100 MΩ
Polarity	DC units are reverse polarity protected
Mechanical	
Mounting	Surface mount with one #10 (M5 x 0.8) screw
Dimensions	H 50.8 mm (2.0"); W 50.8 mm (2.0"); D 30.7 mm (1.21")
Termination	0.25 in. (6.35 mm) male quick connect terminals
Environmental	
Operating/Storage Temperature	-40° to 60°C / -40° to 85°C
Humidity	95% relative, non-condensing
Weight	≅ 2.4 oz (68 g)

Function Diagram

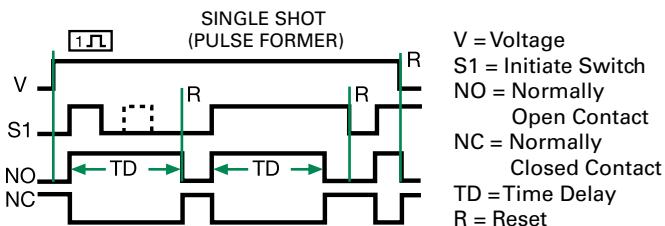

ORS SERIES

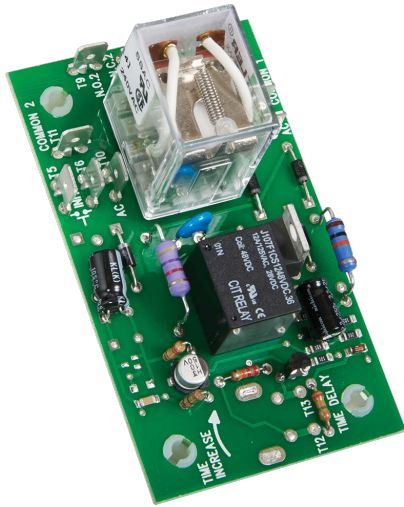

Description

The ORS Series' open PCB construction offers the user good economy without sacrificing performance and reliability. The output relay is available in isolated, 10A, DPDT or SPDT forms. The time delay may be ordered as factory fixed, onboard knob, or external adjustment. All connections are 0.25 in. (6.35 mm) male quick connect terminals.

Operation (Single Shot)

Input voltage must be applied before and during timing. Upon momentary or maintained closure of the initiate switch (leading edge triggered), the output relay energizes for a measured interval of time. At the end of the time delay, the output de-energizes. Opening or reclosing the initiate switch during timing has no effect on the time delay. The output will energize if the initiate switch is closed when input voltage is applied.

Reset: Reset occurs when the time delay is complete and the initiate switch is opened. Loss of input voltage resets the time delay and output.

Wiring Diagram

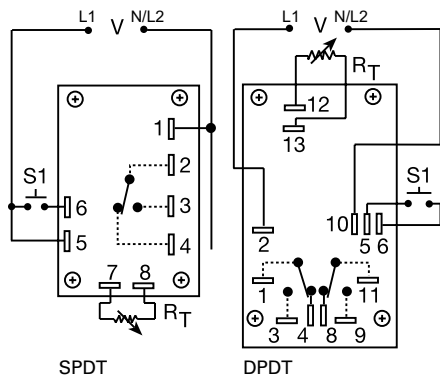

V = Voltage
S1 = Initiate Switch

Relay contacts are isolated.

R_T is used when external adjustment is ordered.

Features & Benefits

FEATURES	BENEFITS
Open PCB construction	Reduces cost without sacrificing performance and reliability
Analog circuitry	Repeat accuracy +/- 2%, Factory calibration +/- 10%
Isolated, 10A, SPDT or DPDT output contacts	Allows control of loads for AC or DC voltages
Line voltage initiation	Separate control voltage is not required for operation

Accessories



P1004-12, P1004-12-X Versa-Pot

Panel mountable, industrial potentiometer recommended for remote time delay adjustment.



P0700-7 Versa-Knob

Designed for 0.25 in (6.35 mm) shaft of Versa-Pot. Semi-gloss industrial black finish.



P1015-64 (AWG 14/16)

Female Quick Connect

These 0.25 in. (6.35 mm) female terminals are constructed with an insulator barrel to provide strain relief.



P1015-18 Quick Connect to Screw Adapter

Screw adapter terminal designed for use with all modules with 0.25 in. (6.35 mm) male quick connect terminals.

For dimensional drawing see: Appendix, page 512, Figure 26.

Ordering Information

MODEL	INPUT VOLTAGE	ADJUSTMENT	TIME DELAY	OUTPUT FORM
ORS120A150SD	120VAC	Fixed	50s	DPDT
ORS230A150SD	230VAC	Fixed	50s	DPDT

If you don't find the part you need, call us for a custom product 800-843-8848

ORS SERIES

Selection Guide

RT Selection Chart					
Desired Time Delay*					RT Megohm
Seconds					
1	2	3	4	5	
0.05	0.5	0.6	1.2	3.0	0.0
0.5	5.0	10	20	50	0.5
1.0	10	20	40	100	1.0
1.5	15	30	60	150	1.5
2.0	20	40	80	200	2.0
2.5	25	50	100	250	2.5
3.0	30	60	120	300	3.0

* When selecting an external RT add at least 20% for tolerance of unit and the RT.

Function Diagram

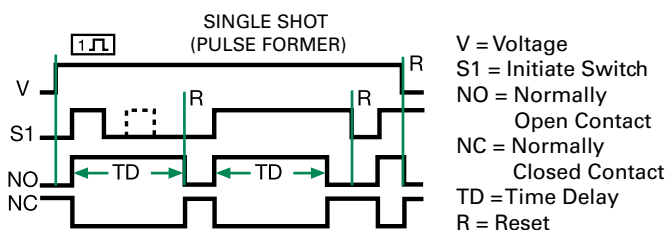

Specifications

Time Delay

Type

Analog circuitry

Range

0.05 - 300s in 5 adjustable ranges or fixed

Repeat Accuracy

±2% or 20ms, whichever is greater

Tolerance

(Factory Calibration)

Adjustable: guaranteed range

Fixed: ±10%

Reset Time

≤ 50ms

Initiate Time

≤ 70ms

Time Delay vs Temp.

≤ ±10%

& Voltage

Input

Voltage

24, 120, or 230VAC

Tolerance

24VAC

-15% - 20%

120 & 230VAC

-20% - 10%

AC Line Frequency

50/60 Hz

Power Consumption

2.25W

Output

Type

Electromechanical relay

Form

Isolated, SPDT or DPDT

Rating

10A resistive @ 120/240VAC & 28VDC;

1/3 hp @ 120/240VAC

Mechanical - 1x10⁷; Electrical - 1x10⁶

Life

Protection

Isolation Voltage

≥1500V RMS input to output

Mechanical

Mounting

Surface mount with four #6 (M3.5 x 0.6) screws

Dimensions

H 53.8 mm (2.12"); **W** 93.7 mm (3.69");

D 47.8 mm (1.88")

0.25 in. (6.35 mm) male quick connect terminals

Termination

Environmental

Operating/Storage

Temperature

-20° to 65°C / -30° to 85°C

Weight

≈ 2.7 oz (77 g)

PRS65

Single Shot Timer



Wiring Diagram

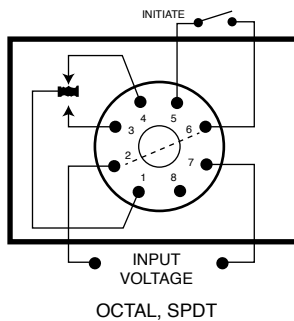

For dimensional drawing see: Appendix, page 515, Figure 48.

Description

The PRS65 is a single shot time delay relay for use on non-critical timing applications. The knob adjustable time delay carries a guaranteed time range of up to 8 minutes.

Operation

Power must be applied to the input at all times prior to and during timing. Upon closure of the initiate switch (momentary or maintained) the output contacts transfer and the time delay is initiated. At the end of the delay interval, the output contacts revert to their original position. If the initiate switch is reclosed during timing, the time delay will not be affected.

Features & Benefits

- Electronic Circuit with Electromechanical Relay
- Popular Operating Voltages
- Octal Plug-in
- Hold Down Clamps Available

Accessories



BZ1 Front Panel Mount Kit

Provides an easy method of through-the-panel mounting of 8- or 11-pin plug-in timers, flashers, and other controls.



NDS-8 Octal 8-pin Socket

8-pin 35mm DIN rail or surface mount. Surface mounted with two #6 (M 3.5 x 0.6) screws or snaps onto a 35 mm DIN rail. Uses PSC8 hold-down clips.

Specifications

Time Delay

Type	Analog circuitry
Range	7 to 480 seconds
Repeat Accuracy	±2% under fixed conditions
Tolerance	Knob adjustable: guaranteed range
Reset Time	80ms max.
Recycle Time	16ms max.
After Timing	0.1% of max. time delay or 75ms, whichever is greater
During Timing	

Time Delay vs. Temp. & Voltage

15% max.

Input

Voltage	230VAC, nominal
Tolerance	±15% of nominal
AC Line Frequency	50/60 Hz

Output

Type	Relay
Form	Single Pole, Double Throw
Rating	10 amperes resistive at 240VAC

Protection

Transient	±1500 volts for 150 microseconds
Dielectric Breakdown	≥1500 V rms min. at 60 Hz between input and output terminals

Mechanical Mounting

Plug in (hold-down clips for panel mounting also available)

Termination Dimensions

Standard Octal Plug-in
H 92.2 mm (3.63"); **W** 60.45 mm (2.38");
D 44.45 mm (1.75")

Environmental Operating/Storage Temperature

-20° to 65°C / -30° to 85°C

Humidity

95% relative, non-condensing

Weight

Approx. 6 oz (170 g)

TDS / TDSH / TDSL SERIES

Relay Output, Single Shot Time Delay Relay



*8-pin models UL listed when used in combination with P1011-6 socket only.



8-PIN



11-PIN

Description

The TDS Series combines accurate digital circuitry with isolated, 10A rated, DPDT or SPDT relay contacts in an 8-pin or 11-pin plug-in package. The TDS Series features DIP switch selectable time delays ranging from 0.1s to 10,230s in three ranges. The TDS Series is the product of choice for custom control panel and OEM designers.

Operation (Single Shot)

Input voltage must be applied to the input before and during timing. Upon momentary or maintained closure of the initiate switch (leading edge triggered), the output relay energizes for a measured interval of time. At the end of the delay, the output de-energizes. Opening or reclosing the initiate switch during timing has no effect on the time delay. The output will energize if the initiate switch is closed when input voltage is applied.

Reset: Reset occurs when the time delay is complete and the initiate switch is opened. Loss of input voltage resets the time delay and output.

Wiring Diagram

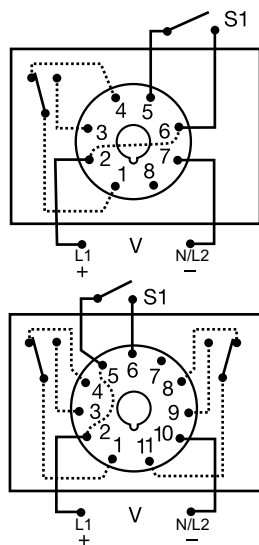

8-PIN OCTAL SPDT

S1 = Initiate Switch
Relay contacts are isolated.

11-PIN DPDT

Features & Benefits

FEATURES	BENEFITS
3 time ranges available (0.1s to 2.8h)	Makes it versatile for use in many applications
Microcontroller based	Repeat Accuracy +/- 0.1% or 20ms, whichever is greater; Setting Accuracy +/- 2% or 50ms, whichever is greater
LED indication (select models)	Provides visual indication of relay status
DIP switch adjustment	Provides first time setting accuracy
Isolated output contacts	Allows control of loads for AC or DC voltages

For dimensional drawing see: Appendix, page 512, Figure 23.

Ordering Information

MODEL	INPUT VOLTAGE	DELAY RANGE (SEC)	LED	PLUG TYPE/OUTPUT FORM
TDS120AL	120VAC	1-1023 in 1s increments	X	Octal (8-pin) plug, SPDT
TDS120ALD	120VAC	1-1023 in 1s increments	X	11-pin plug, DPDT
TDS12D	12VDC	1-1023 in 1s increments		Octal (8-pin) plug, SPDT
TDS230AL	230VAC	1-1023 in 1s increments	X	Octal (8-pin) plug, SPDT
TDS24AL	24VAC	1-1023 in 1s increments	X	Octal (8-pin) plug, SPDT
TDSH120AL	120VAC	10-10230 in 10s increments	X	Octal (8-pin) plug, SPDT
TDSL120AL	120VAC	0.1-102.3 in 0.1s increments	X	Octal (8-pin) plug, SPDT
TDSL12D	12VDC	0.1-102.3 in 0.1s increments		Octal (8-pin) plug, SPDT

If you don't find the part you need, call us for a custom product 800-843-8848

TDS / TDSH / TDSL SERIES

Accessories



BZ1 Front Panel Mount Kit
Provides an easy method of through-the-panel mounting of 8- or 11-pin plug-in timers, flashers, and other controls.



NDS-8 Octal 8-pin Socket
8-pin 35mm DIN rail or surface mount. Rated at 10A @ 300VAC. Surface mounted with two #6 (M 3.5 x 0.6) screws or snaps onto a 35 mm DIN rail. Uses PSC8 hold-down clips.



NDS-11 11-pin Socket
11-pin 35mm DIN rail or surface mount. Rated at 10A @ 300VAC. Surface mounted with two #6 (M 3.5 x 0.6) screws or snaps onto a 35 mm DIN rail. Uses PSC11 hold-down clips.



PSC8 or PSC11 Hold-down Clips
Securely mounts plug-in controls in any position. Provides protection against vibration. Use PSC8 with NDS-8 Octal Socket or PSC11 with NDS-11 Socket. Sold in pairs.



PSCBR8 Hold-down Brackets
Designed for use with P1011-6 socket. Securely mounts 8-pin plug-in controls in any position, and provides protection against vibration. Sold in pairs.



P1011-6 Octal Socket for UL listing*
8-pin surface mount socket with binder head screw terminals. Rated 10A @ 600VAC. Uses PSCBR8 Hold-down Brackets.

*8-pin models UL listed when used in combination with P1011-6 socket only.

Digi-Set Binary Switch Operation

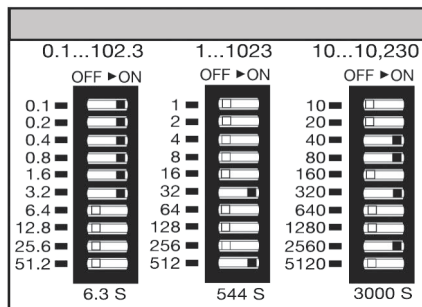

**For CE approved applications, power must be removed from the unit when a switch position is changed.

Specifications

Time Delay
Type
Range**

Digital integrated circuitry
0.1 - 102.3s in 0.1s increments
1 - 1023s in 1s increments
10 - 10,230s in 10s increments

Repeat Accuracy
Setting Accuracy
Reset Time
Recycle Time
Time Delay vs Temp. & Voltage

±0.1% or 20ms, whichever is greater
±2% or 50ms, whichever is greater
≤ 50ms
≤ 150ms

Indicator
Initiate Time
Input

±5%
LED glows during timing; relay is energized
≤ 60ms

Voltage
Tolerance

12, 24/28, or 110VDC; 24, 120, or 230VAC

12VDC & 24VDC/AC
110 to 230VAC/DC
AC Line Frequency
Power Consumption

-15% - 20%
-20% - 10%
50/60 Hz
≤ 3.25W

Output

Type
Form
Rating

Electromechanical relay
SPDT or DPDT
10A resistive @ 120/240VAC & 28VDC;
1/3 hp @ 120/240VAC
Mechanical - 1 x 10⁷; Electrical - 1 x 10⁶

Life

Protection
Isolation Voltage
Polarity

≥ 1500V RMS input to output
DC units are reverse polarity protected

Mechanical
Mounting
Termination
Dimensions

Plug-in socket
Octal 8-pin plug-in or 11-pin plug-in
H 81.3 mm (3.2"); **W** 60.7 mm (2.39");
D 45.2 mm (1.78")

Environmental
Operating/Storage
Temperature
Weight

-20° to 65°C/-30° to 85°C
≈ 6 oz (170 g)

Function Diagram

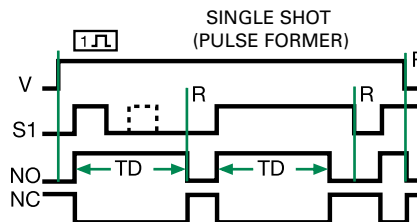

V = Voltage
S1 = Initiate Switch
NO = Normally Open Contact
NC = Normally Closed Contact
TD = Time Delay
R = Reset

TDUS SERIES

Single Shot Timer



Description

The TDUS Series combines digital timing circuitry with universal voltage operation. Voltages of 24 to 240VAC and 12 to 24VDC are available in three ranges. The TDUS Series offers DIP switch selectable time delays ranging from 0.1 seconds to 102.3 minutes in three ranges. Its 1A rated output, ability to operate on multiple voltages, and wide range of switch selectable time delays make the TDUS Series an excellent choice for process control systems and OEM equipment.

Operation (Single Shot)

Input voltage must be applied before and during timing. Upon momentary or maintained closure of the initiate switch (leading edge triggered), the output energizes for a measured interval of time. At the end of the delay, the output de-energizes. Opening or reclosing the initiate switch during timing has no effect on the time delay. The output will energize if the initiate switch is closed when input voltage is applied.

Reset: Reset occurs when the time delay is complete and the initiate switch is opened. Loss of input voltage resets the time delay and output.

Wiring Diagram

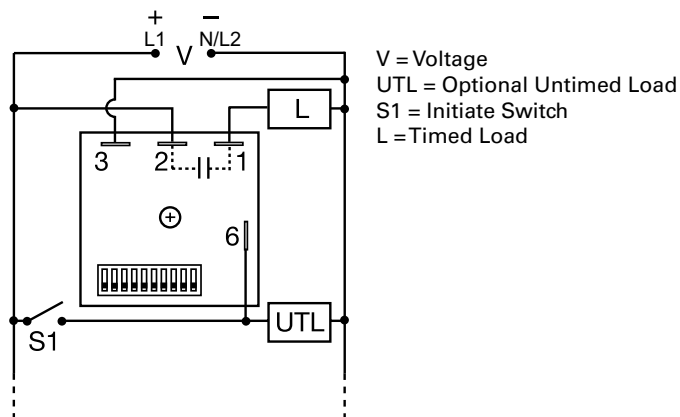

For dimensional drawing see: Appendix, page 512, Figure 16.

Features & Benefits

FEATURES	BENEFITS
Microcontroller based	Repeat Accuracy +/- 0.1%
Compact design	Allows flexibility for OEM applications
1A steady, 10A inrush solid-state output	Provides 100 million operations in typical conditions.
Totally solid state and encapsulated	No moving parts to arc and wear out over time and encapsulated to protect against shock, vibration, and humidity

Accessories



P0700-7 Versa-Knob

Designed for 0.25 in. (6.35 mm) shaft of Versa-Pot. Semi-gloss industrial black finish.



P1015-64 (AWG 14/16) Female Quick Connect

These 0.25 in. (6.35 mm) female terminals are constructed with an insulator barrel to provide strain relief.



P1015-18 Quick Connect to Screw Adapter

Screw adapter terminal designed for use with all modules with 0.25 in. (6.35 mm) male quick connect terminals.



C103PM (AL) DIN Rail

35 mm aluminum DIN rail available in a 36 in. (91.4 cm) length.



P1023-20 DIN Rail Adapter

Allows module to be mounted on a 35 mm DIN type rail with two #10 screws.

Ordering Information

MODEL	INPUT VOLTAGE	TIME RANGE
TDUS3000A	24 to 120VAC	1 - 1023s
TDUS3001A	100 to 240VAC	1 - 1023s
TDUS3002A	12 to 24VDC	1 - 1023s
TDUSH3001A	100 to 240VAC	0.1 - 102.3m
TDUSL3000A	24 to 120VAC	0.1 - 102.3s

If you don't find the part you need, call us for a custom product 800-843-8848

TDUS SERIES

Specifications

Time Delay

Range*	0.1 - 102.3s in 0.1s increments 1 - 1023s in 1s increments 0.1 - 102.3m in 0.1m increments
Repeat Accuracy	±0.5% or 20 ms, whichever is greater
Setting Accuracy	≤ ±2% or 20 ms, whichever is greater
Reset Time	≤ 150ms
Initiate Time	≤ 20ms

Time Delay vs. Temperature & Voltage

≤ ±5%

Input

Voltage/Tolerance	24 to 240VAC, 12 to 24VDC / ±20%
AC Line Frequency/DC Ripple	50/60 Hz / ≤ 10%
Power Consumption	AC ≤ 2VA; DC ≤ 1W

Output

Type	Solid state
Form	NO, closed during timing
Rating	1A steady state, 10A inrush at 60°C
Voltage Drop	AC ≈ 2.5V @ 1A; DC ≈ 1V @ 1A
Off State Leakage Current	AC ≈ 5mA @ 230VAC; DC ≈ 1 mA

Protection

Circuitry	Encapsulated
Dielectric Breakdown	≥ 2000V RMS terminals to mounting surface
Insulation Resistance	≥ 100 MΩ
Polarity	DC units are reverse polarity protected

Mechanical

Mounting	Surface mount with one #10 (M5 x 0.8) screw
Dimensions	H 50.8 mm (2"); W 50.8 mm (2"); D 30.7 mm (1.21")
Termination	0.25 in. (6.35 mm) male quick connect terminals

Environmental

Operating/Storage Temperature	-40° to 60°C / -40° to 85°C
Humidity	95% relative, non-condensing
Weight	≈ 2.4 oz (68 g)

*For CE approved applications, power must be removed from the unit when a switch position is changed.

Adjustment Switch Operation

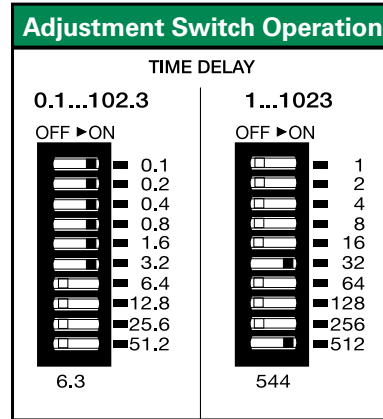

Function Diagram

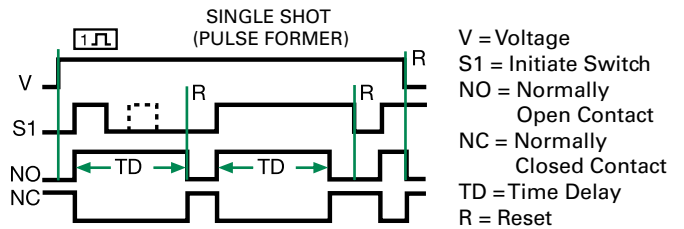

THC / THS SERIES



Wiring Diagram

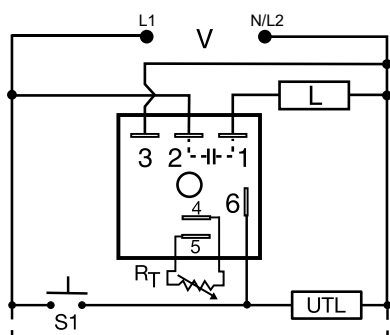

V = Voltage
S1 = Initiate Switch
L = Timed Load
UTL = Optional Untimed Load

RT is used when external adjustment is ordered.

For dimensional drawing see: Appendix, page 512, Figure 19.

Description

The THC/THS Series is a solid-state relay and timer combined into one compact, easy-to-use control. When mounted to a metal surface, the THC/THS Series may be used to directly control lamp or heater loads of up to 20A steady, 200A inrush. Its single shot function can perform dispensing and pulse shaping operations. The initiate switch can be a momentary or maintained type of switch. Time delays can be selected from 0.1 - 600 seconds in 4 ranges. The THC/THS Series is used for coin vending applications where fast initiate response is required.

Operation (Single Shot)

Input voltage must be applied before and during timing. Upon momentary or maintained closure of the initiate switch (leading edge triggered), the output energizes for a measured interval of time. At the end of the delay, the output de-energizes. Opening or reclosing the initiate switch during timing has no effect on the time delay. The output will energize if the initiate switch is closed when input voltage is applied.

Reset: Reset occurs when the time delay is complete and the initiate switch opens. Loss of input voltage resets the time delay and output.

Features & Benefits

FEATURES	BENEFITS
Analog circuitry	Repeat accuracy +/- 2%, Factory calibration +/- 5%
Compact, low cost design	Allows flexibility for OEM applications and reduces labor and component costs
High load currents up to 20A, 200A inrush	Allows direct operation of motors, lamps, and heaters directly without a contactor
Totally solid state and encapsulated	No moving parts to arc and wear out over time and encapsulated to protect against shock, vibration, and humidity
Metalized mounting surface	Facilitates heat transfer in high current applications

Accessories



P1004-95, P1004-95-X Versa-Pot
Panel mountable, industrial potentiometer recommended for remote time delay adjustment.



P0700-7 Versa-Knob
Designed for 0.25 in (6.35 mm) shaft of Versa-Pot. Semi-gloss industrial black finish.



P1015-13 (AWG 10/12), P1015-64 (AWG 14/16) Female Quick Connect
These 0.25 in. (6.35 mm) female terminals are constructed with an insulator barrel to provide strain relief.



P1015-18 Quick Connect to Screw Adapter
Screw adapter terminal designed for use with all modules with 0.25 in. (6.35 mm) male quick connect terminals.

Ordering Information

MODEL	INPUT VOLTAGE	ADJUSTMENT	TIME DELAY	OUTPUT RATING
THC421C	120VAC	External	0.1 - 3s	20A
THS422B	120VAC	External	0.5 - 60s	10A
THS422C	120VAC	External	0.5 - 60s	20A

If you don't find the part you need, call us for a custom product 800-843-8848

THC / THS SERIES

Selection Guide

RT Selection Chart				
Desired Time Delay*				RT
Seconds				
1	2	3	4	Kohms
0.1	0.5	2	5	0
0.3	6	20	60	10
0.6	12	38	120	20
0.9	18	55	180	30
1.2	24	73	240	40
1.5	30	90	300	50
1.8	36	108	360	60
2.1	42	126	420	70
2.4	48	144	480	80
2.7	54	162	540	90
3.0	60	180	600	100

* When selecting an external RT add at least 20% for tolerance of unit and the RT.

Function Diagram

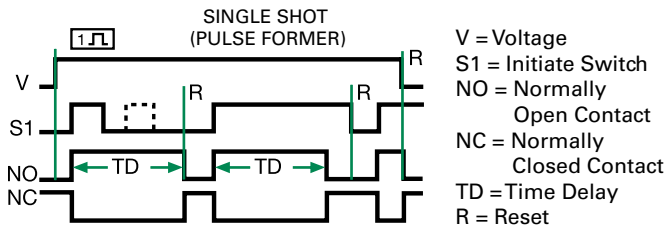

Specifications

Time Delay

Range 0.1 - 600s in 4 adjustable ranges or fixed
Repeat Accuracy ±2% or 20ms, whichever is greater

Tolerance (Factory Calibration) ≤ ± 5%

Reset Time ≤ 150ms

Initiate Time ≤ 20ms

Time Delay vs Temp. & Voltage ≤ ±10%

Input

Voltage 24, 120, or 230VAC

Tolerance ±15%

AC Line Frequency 50/60 Hz

Power Consumption ≤ 2VA

Output

Type Solid state

Form NO, closed during timing

Maximum Load Currents

Output	Steady State	Inrush**
A	6A	60A
B	10A	100A
C	20A	200A

Minimum Load Current 100mA

Voltage Drop ≈ 2.5V at rated current

OFF State Leakage Current ≈ 5mA @ 230VAC

Protection

Circuitry Encapsulated

Dielectric Breakdown ≥ 2000V RMS terminals to mounting surface

Insulation Resistance ≥100 MΩ

Mechanical

Mounting **

Surface mount with one #10 (M5 x 0.8) screw

Dimensions

H 50.8 mm (2.0"); **W** 50.8 mm (2.0");

D 38.4 mm (1.51")

0.25 in. (6.35 mm) male quick connect terminals

Termination

Environmental

Operating/Storage

Temperature

-20° to 60°C / -40° to 85°C

Humidity

95% relative, non-condensing

Weight

≈ 3.9 oz (111 g)

**Must be bolted to a metal surface using the included heat sink compound. The maximum mounting surface temperature is 90°C. Inrush: Non-repetitive for 16ms.

THDS SERIES

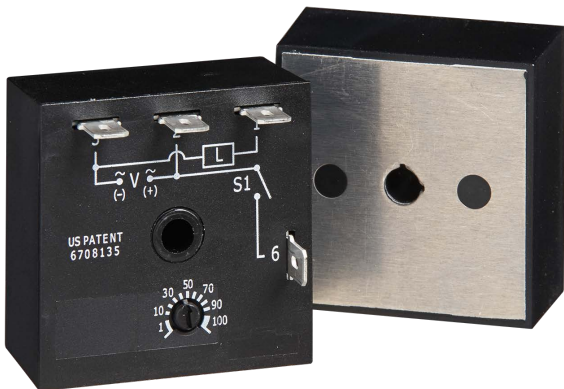

Description

The THDS Series combines accurate timing circuitry with high power solid-state switching. It can switch motors, lamps, and heaters directly without a contactor. You can reduce labor, component cost, and increase reliability with these small, easy-to-use, timers.

Operation (Single Shot)

Input voltage must be applied before and during timing. Upon momentary or maintained closure of the initiate switch, the output energizes for a measured interval of time. At the end of the delay, the output de-energizes. Opening or reclosing the initiate switch during timing has no effect on the time delay. The output energizes if the initiate switch is closed when input voltage is applied.

Reset: Reset occurs when the time delay is complete and the initiate switch is opened. Loss of input voltage resets the time delay and output.

Wiring Diagram

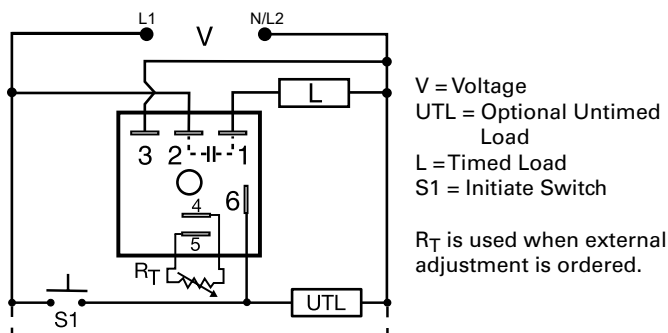

For dimensional drawing see: Appendix, page 512, Figure 19.

Features & Benefits

FEATURES	BENEFITS
Microcontroller based	Repeat Accuracy +/- 0.5%, Factory calibration +/- 1%
High load currents up to 20A, 200A inrush	Allows direct operation of motors, lamps and heaters without a contactor
Totally solid state and encapsulated	No moving parts to arc and wear out over time and encapsulated to protect against shock, vibration, and humidity
Metalized mounting surface	Facilitates heat transfer in high current applications
Compact, low cost design	Allows flexibility for OEM applications and reduces labor and component costs

Accessories



P1004-95, P1004-95-X Versa-Pot

Panel mountable, industrial potentiometer recommended for remote time delay adjustment.



P0700-7 Versa-Knob

Designed for 0.25 in. (6.35 mm) shaft of Versa-Pot. Semi-gloss industrial black finish.



P1015-64 (AWG 14/16)

Female Quick Connect

These 0.25 in. (6.35 mm) female terminals are constructed with an insulator barrel to provide strain relief.



P1015-18 Quick Connect to Screw Adapter

Screw adapter terminal designed for use with all modules with 0.25 in. (6.35 mm) male quick connect terminals.

Ordering Information

MODEL	INPUT VOLTAGE	ADJUSTMENT	TIME DELAY	OUTPUT RATING
THDS410.25SA	120VAC	Fixed	0.25s	6A
THDS431C	120VAC	Onboard	1 - 100s	20A
THDS610.25SA	230VAC	Fixed	0.25s	6A

If you don't find the part you need, call us for a custom product 800-843-8848

THDS SERIES

External Resistance vs. Time Delay

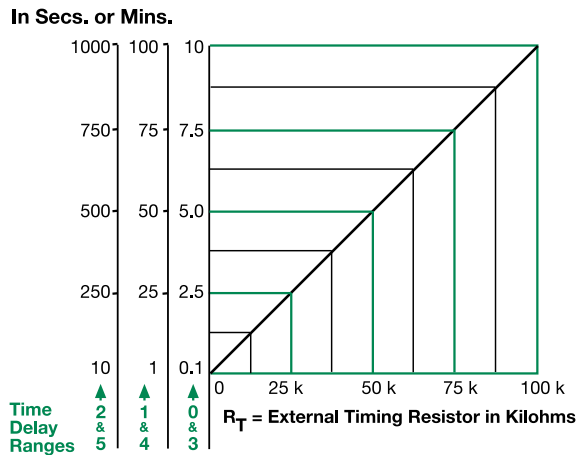

This chart applies to externally adjustable part numbers.
The time delay is adjustable over the time delay range selected by varying the resistance across the R_T terminals; as the resistance increases the time delay increases.

When selecting an external R_T, add the tolerances of the timer and the R_T for the full time range adjustment.

Examples: 1 to 50 S adjustable time delay, select time delay range 1 and a 50 K ohm R_T. For 1 to 100 S use a 100 K ohm R_T.

Function Diagram

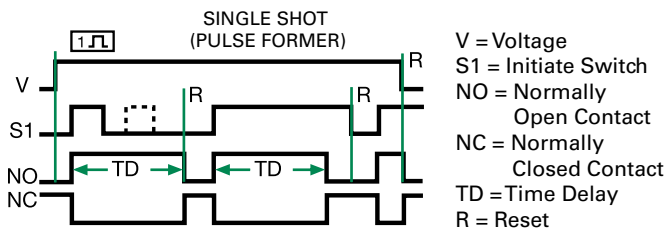

Specifications

Time Delay	0.1s - 1000m in 6 adjustable ranges or fixed
Range	±0.5% or 20ms, whichever is greater
Repeat Accuracy	
Tolerance (Factory Calibration)	≤ ±1%
Reset Time	≤ 150ms
Initiate Time	≤ 20ms
Time Delay vs Temp. & Voltage	≤ ±2%
Input Voltage	24, 120, or 230VAC
Tolerance	±20%
AC Line Frequency	50/60 Hz
Power Consumption	≤ 2VA
Output Type	Solid state
Form	NO, closed during timing
Maximum Load Current	
	Output Steady State Inrush**
	A 6A 60A
	B 10A 100A
	C 20A 200A
Voltage Drop	≅ 2.5V @ rated current
Off State Leakage Current	≅ 5mA @ 230VAC
Minimum Load Current	100mA
Protection	
Circuitry	Encapsulated
Dielectric Breakdown	≥ 2000V RMS terminals to mounting surface
Insulation Resistance	≥ 100 MΩ
Mechanical	
Mounting **	Surface mount with one #10 (M5 x 0.8) screw
Dimensions	H 50.8 mm (2.0"); W 50.8 mm (2.0"); D 38.4 mm (1.51")
Termination	0.25 in. (6.35 mm) male quick connect terminals
Environmental	
Operating/Storage Temperature	-40° to 60°C / -40° to 85°C
Humidity	95% relative, non-condensing
Weight	≅ 3.9 oz (111 g)

**Must be bolted to a metal surface using the included heat sink compound. The maximum mounting surface temperature is 90°C. Inrush: Non-repetitive for 16ms.

TRS SERIES



*8-pin models UL listed when used in combination with P1011-6 socket only.



8-PIN



11-PIN

Description

The TRS Series combines an isolated, 10A electromechanical, relay output with analog timing circuitry. False trigger of the TRS Series by a transient is unlikely because of the complete isolation of the circuit from the line prior to initiation. The initiate contact is common to one side of the line and may be utilized to operate other loads. Installation is easy due to the TRS's industry standard 8 or 11-pin plug-in base wiring.

Operation (Single Shot)

Input voltage must be applied to the input before and during timing. Upon momentary or maintained closure of the initiate switch (leading edge triggered), the output energizes for a measured interval of time. At the end of the delay, the output de-energizes. Opening or reclosing the initiate switch during timing has no effect on the time delay. Applying input voltage with the initiate switch closed will energize the load and begin the time delay.

Reset: Reset occurs when the time delay is complete and the initiate switch is opened. Loss of input voltage resets the time delay and output.

Wiring Diagram

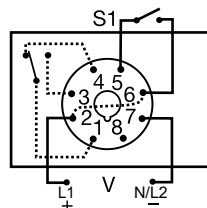

8-PIN OCTAL SPDT

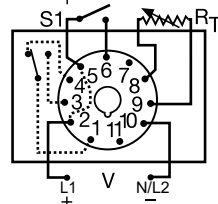

11-PIN SPDT

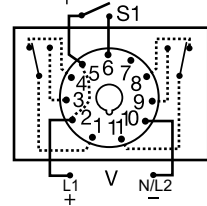

11-PIN DPDT

For dimensional drawing see: Appendix, page 512, Figure 24.

Ordering Information

MODEL	INPUT VOLTAGE	ADJUSTMENT	OUTPUT FORM	TIME TOLERANCE	TIME DELAY
TRS120A2X300	120VAC	Knob	8-Pin, Octal, SPDT	+ / - 20%	7 - 300s
TRS120A2Y10	120VAC	Knob	8-Pin, Octal, SPDT	+ / - 10%	0.1 - 10s
TRS24D7Z10	24VDC/28VDC	External	11-Pin, SPDT no potentiometer	+ / - 5%	0.1 - 10s

If you don't find the part you need, call us for a custom product 800-843-8848

Features & Benefits

FEATURES	BENEFITS
Complete isolation of circuit from line	No false trip due to transients
Industry standard octal plug connection	Eliminates need for special connectors
Isolated, 10A, SPDT or DPDT output contacts	Allows control of loads for AC or DC voltages
Analog circuitry	Repeat accuracy + / - 2%

TRS SERIES

Accessories



BZ1 Front Panel Mount Kit
Provides an easy method of through-the-panel mounting of 8- or 11-pin plug-in timers, flashers, and other controls.



NDS-8 Octal 8-pin Socket
8-pin 35mm DIN rail or surface mount. Surface mounted with two #6 screws or snaps onto a 35 mm DIN rail. Uses PSC8 hold-down clips.



NDS-11 11-pin Socket
11-pin 35mm DIN rail or surface mount. Surface mounted with two #6 screws or snaps onto a 35 mm DIN rail. Uses PSC11 hold-down clips.



PSC8 or PSC11 Hold-down Clips
Securely mounts plug-in controls in any position. Provides protection against vibration. Use PSC8 with NDS-8 Octal Socket or PSC11 with NDS-11 Socket. Sold in sets of two.



P1011-6 Octal Socket for UL listing*
8-pin surface mount socket with binder head screw terminals. Rated 10A @ 600VAC.



P0700-7 Versa-Knob
Designed for 0.25 in (6.35 mm) shaft of Versa-Pot. Semi-gloss industrial black finish.

*8-pin models UL listed when used in combination with P1011-6 socket only.

Selection Guides

R _T Selection Chart	
Time Delay*	
Range	R _T
Seconds	Megohm
0.05...1	1.0
0.05...2	2.0
0.05...3	3.0
0.1...5	5.0
0.1...10	3.0
1...30	1.5
1...60	3.0
2...120	2.0
2...180	3.0
7...240	1.5
7...300	2.0
7...360	2.0
7...420	3.0
7...480	3.0
7...600	5.0

* When selecting an external R_T add at least 15...30% for tolerance of unit and the R_T.

External R _T P/N Selection Table	
VALUE	PART NUMBER*
1M ohm	P1004-16
1.5M ohm	P1004-15
2M ohm	P1004-14
3M ohm	P1004-12
5M ohm	P1004-13
1M ohm	P1004-16-X
1.5M ohm	P1004-15-X
2M ohm	P1004-14-X
3M ohm	P1004-12-X
5M ohm	P1004-13-X

* Externally adjustable potentiometers. Numbers with additional "-X" include two pre-soldered 8" wire leads with ¼" female quick-connect terminals (for clockwise increase).

Specifications

Time Delay

Type Analog circuitry
Range 0.05s - 10m in 15 adjustable ranges or fixed
Repeat Accuracy ±2% or 20ms, whichever is greater

Fixed Time Tolerance & Setting Accuracy

±5, 10, or 20%

Initiate Time

≤ 70ms

Reset Time

≤ 75ms

Recycle Time

≤ 250ms

Time Delay vs Temp. & Voltage

≤ ±10%

Input

Voltage 24/28 or 110VDC; 24, 120, or 230VAC

Tolerance

24VDC/AC

-15% - 20%

110 to 230VAC/DC

-20% - 10%

AC Line Frequency

50/60 Hz

Power Consumption

≤ 3.25W

Output

Type

Electromechanical relay

Form

Isolated SPDT or DPDT

Rating

10A resistive @ 120/240VAC & 28VDC;

1/3 hp @ 120/240VAC

Mechanical - 1 x 10⁷; Electrical - 1 x 10⁶

Life

Protection

≥ 100 MΩ

Insulation Resistance

≥ 1500V RMS between input & output terminals

Isolation Voltage

DC units are reverse polarity protected

Polarity

Mechanical

Mounting

Plug-in socket

Termination

Octal 8-pin plug-in or 11-pin plug-in

Dimensions

H 60.7 mm (2.39"); **W** 45.2 mm (1.78")

D 91.6 mm (3.62")

Environmental

Operating/Storage

Temperature

-20° to 65°C/-30° to 85°C

Weight

≈ 6 oz (170 g)

Function Diagram

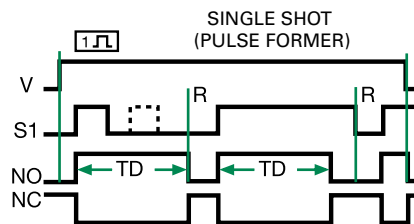

V = Voltage
S1 = Initiate Switch
NO = Normally Open Contact
NC = Normally Closed Contact
TD = Time Delay
R = Reset

TSDS SERIES

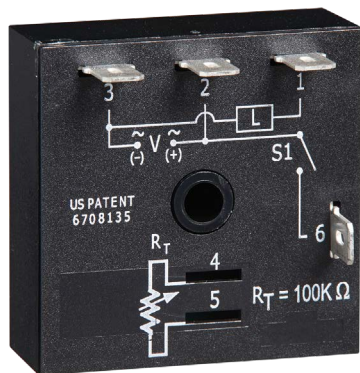

Description

The TSDS Series is designed for more demanding commercial and industrial applications where small size and accurate performance are required. The factory calibration for fixed time delays is within 1% of the target time delay. The repeat accuracy, under stable conditions, is 0.5% of the time delay. The TSDS Series is rated to operate over an extended temperature range. Time delays of 0.1 seconds to 1000 minutes are available. The output is rated 1A steady and 10A inrush. The modules are totally solid state and encapsulated to protect the electronic circuitry. This product is suitable for many applications, including dispensing, welding, and exposure timing.

Operation (Single Shot)

Input voltage must be applied before and during timing. Upon momentary or maintained closure of the initiate switch, the output energizes for a measured interval of time. At the end of the delay, the output de-energizes. Opening or reclosing the initiate switch during timing has no effect on the time delay. The output will not energize if the initiate switch is closed when input voltage is applied.

Reset: Reset occurs when the time delay is complete and the initiate switch is opened. Loss of input voltage resets the time delay and output.

Features & Benefits

FEATURES	BENEFITS
Compact, low cost design measuring 2 in. (50.8mm) square	Allows flexibility for OEM applications
Microcontroller based	Repeat Accuracy +/- 0.5%, Factory calibration +/- 1%
1A Steady, 10A inrush solid-state output	Provides 100 million operations in typical conditions.
Totally solid state and encapsulated	No moving parts to arc and wear out over time and encapsulated to protect against shock, vibration, and humidity
Wide temperature range: -40° to 75°C	Reliable in demanding commercial and industrial applications

Wiring Diagram

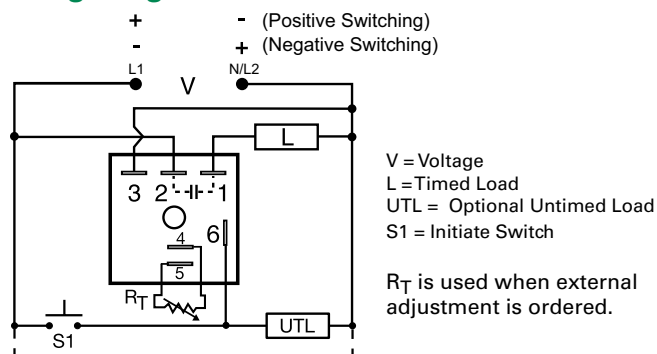

For dimensional drawing see: Appendix, page 512, Figure 16.

Ordering Information

MODEL	INPUT VOLTAGE	ADJUSTMENT	TIME DELAY	SWITCHING MODE
TSDS2110S	24VAC	Fixed	10s	n/a
TSDS320N	24VDC	External	0.1 - 10s	Negative
TSDS321P	24VDC	External	1 - 100s	Positive
TSDS421	120VAC	External	1 - 100s	n/a

If you don't find the part you need, call us for a custom product 800-843-8848

Accessories



P1004-95, P1004-95-X Versa-Pot
Panel mountable, industrial potentiometer recommended for remote time delay adjustment.



P1023-6 Mounting bracket
The 90° orientation of mounting slots makes installation/removal of modules quick and easy.



P0700-7 Versa-Knob
Designed for 0.25 in (6.35 mm) shaft of Versa-Pot. Semi-gloss industrial black finish.

TSDS SERIES

Accessories



P1015-64 (AWG 14/16) Female Quick Connect
These 0.25 in. (6.35 mm) female terminals are constructed with an insulator barrel to provide strain relief.



P1015-18 Quick Connect to Screw Adapter
Screw adapter terminal designed for use with all modules with 0.25 in. (6.35 mm) male quick connect terminals.



C103PM (AL) DIN Rail
35 mm aluminum DIN rail available in a 36 in. (91.4 cm) length.



P1023-20 DIN Rail Adapter
Allows module to be mounted on a 35 mm DIN type rail with two #10 screws.

External Resistance vs. Time Delay

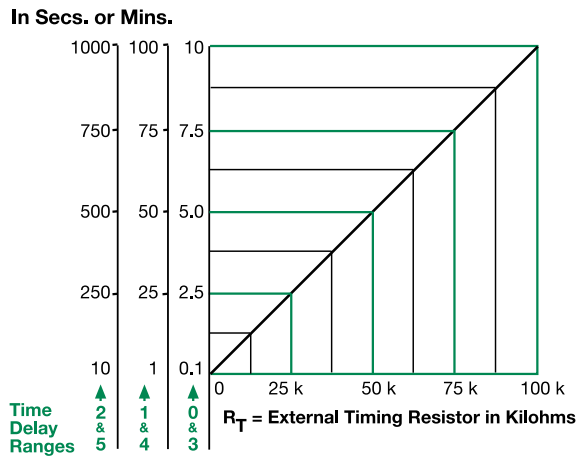

This chart applies to externally adjustable part numbers.
The time delay is adjustable over the time delay range selected by varying the resistance across the R_T terminals; as the resistance increases the time delay increases.

When selecting an external R_T , add the tolerances of the timer and the R_T for the full time range adjustment.

Examples: 1 to 50 S adjustable time delay, select time delay range 1 and a 50 K ohm R_T . For 1 to 100 S use a 100 K ohm R_T .

Function Diagram

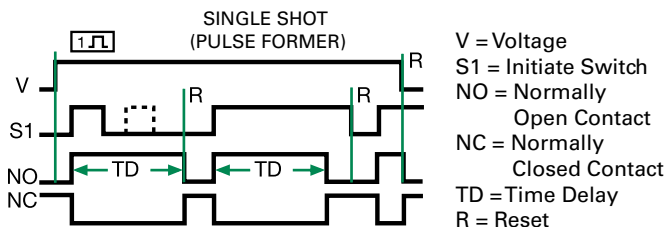

Specifications

Time Delay Range	0.1s - 1000ms in 6 adjustable ranges or fixed
Repeat Accuracy	±0.5% or 20ms, whichever is greater
Tolerance (Factory Calibration)	≤ ±1%
Reset Time	≤ 150ms
Initiate Time	≤ 20ms
Time Delay vs Temp. & Voltage	≤ ±2%
Input Voltage	12 or 24VDC; 24, 120, or 230VAC
Tolerance	±15%
Power Consumption	AC ≤ 2VA; DC ≤ 1W
AC Line Frequency/DC Ripple	50/60 Hz / ≤ 10%
Output Type	Solid state
Form	NO, closed during timing
Maximum Load Current	1A steady state, 10A inrush at 60°C
Voltage Drop	AC ≅ 2.5V @ 1A; DC ≅ 1V @ 1A
Off State Leakage Current	AC ≅ 5mA @ 230VAC; DC ≅ 1mA
DC Operation	Positive or negative switching
Protection	
Circuitry	Encapsulated
Dielectric Breakdown	≥ 2000V RMS terminals to mounting surface
Insulation Resistance	≥ 100 MΩ
Polarity	DC units are reverse polarity protected
Mechanical	
Mounting	Surface mount with one #10 (M5 x 0.8) screw
Dimensions	H 50.8 mm (2.0"); W 50.8 mm (2.0"); D 30.7 mm (1.21")
Termination	0.25 in. (6.35 mm) male quick connect terminals
Environmental	
Operating/Storage Temperature	-40° to 75°C / -40° to 85°C
Humidity	95% relative, non-condensing
Weight	≅ 2.4 oz (68 g)

TSS SERIES

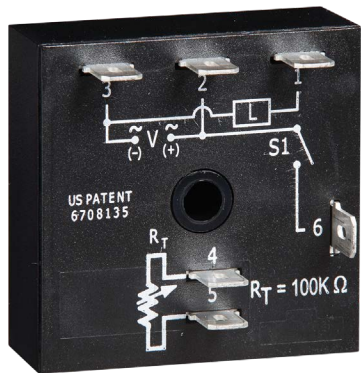

Wiring Diagram

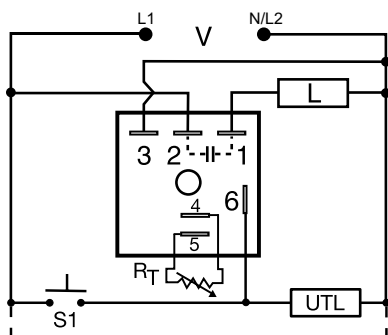

V = Voltage
S1 = Initiate Switch
L = Timed Load
UTL = Optional Untimed Load

RT is used when external adjustment is ordered.

For dimensional drawing see: Appendix, page 512, Figure 16.

Description

The TSS Series is a totally solid-state timing module. Its 1A rated, solid-state output provides an excellent method of time control for exposures, dispensing, or for increasing or decreasing a switch closure. Time delays from 0.05 to 600 seconds, in 4 ranges, cover 90% of all OEM applications. Factory calibration of fixed delays is $\pm 5\%$ and the repeat accuracy is $\pm 2\%$. The TSS Series can be surface mounted with a single screw, or snapped on a 35mm DIN rail using the P1023-20 accessory adaptor.

Operation (Single Shot)

Voltage must be applied before and during timing. Upon momentary or maintained closure of the initiate switch, the output energizes for a measured interval of time. At the end of the delay, the output de-energizes. Opening or reclosing the initiate switch during timing has no effect on the time delay. The output will energize if the initiate switch is closed when input voltage is applied.

Reset: Reset occurs when the time delay is complete and the initiate switch opens. Loss of input voltage resets the time delay and output.

Features & Benefits

FEATURES	BENEFITS
Analog circuitry	Repeat accuracy $\pm 2\%$, Factory calibration $\pm 5\%$
Compact, low cost design	Allows flexibility for OEM applications
Totally solid state and encapsulated	No moving parts to arc and wear out over time and encapsulated to protect against shock, vibration, and humidity
Surface or DIN rail mounting	Provides flexibility for installation

Accessories



P1004-95, P1004-95-X Versa-Pot
Panel mountable, industrial potentiometer recommended for remote time delay adjustment.



P1023-6 Mounting bracket
The 90° orientation of mounting slots makes installation/removal of modules quick and easy.



P0700-7 Versa-Knob
Designed for 0.25 in (6.35 mm) shaft of Versa-Pot. Semi-gloss industrial black finish.



P1015-64 (AWG 14/16) Female Quick Connect
These 0.25 in. (6.35 mm) female terminals are constructed with an insulator barrel to provide strain relief.

Ordering Information

MODEL	INPUT VOLTAGE	ADJUSTMENT	TIME DELAY
TSS410.5	120VAC	Fixed	0.5s
TSS421	120VAC	External	0.05 - 3s
TSS422	120VAC	External	0.5 - 60s
TSS424	120VAC	External	5 - 600s
TSS622	230VAC	External	0.5 - 60s
TSS624	230VAC	External	5 - 600s

If desired part number is not listed, please call us to see if it is technically possible to build.

TSS SERIES

Accessories



P1015-18 Quick Connect to Screw Adapter
Screw adapter terminal designed for use with all modules with 0.25 in. (6.35 mm) male quick connect terminals.



C103PM (AL) DIN Rail
35 mm aluminum DIN rail available in a 36 in. (91.4 cm) length.



P1023-20 DIN Rail Adapter
Allows module to be mounted on a 35 mm DIN type rail with two #10 screws.

Selection Guide

RT Selection Chart				
Desired Time Delay*				RT
Seconds				
1	2	3	4	Kohms
0.05	0.5	2	5	0
0.3	6	20	60	10
0.6	12	38	120	20
0.9	18	55	180	30
1.2	24	73	240	40
1.5	30	90	300	50
1.8	36	108	360	60
2.1	42	126	420	70
2.4	48	144	480	80
2.7	54	162	540	90
3.0	60	180	600	100

* When selecting an external RT add at least 20% for tolerance of unit and the RT.

Function Diagram

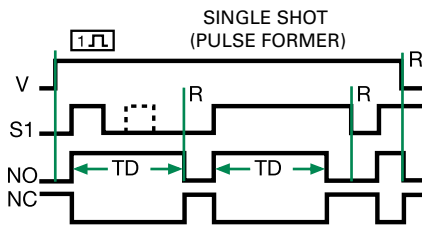

V = Voltage
S1 = Initiate Switch
NO = Normally Open Contact
NC = Normally Closed Contact
TD = Time Delay
R = Reset

Specifications

Time Delay

Range

0.05s - 600s in 4 adjustable ranges or fixed

Repeat Accuracy

±2% or 20ms, whichever is greater

Tolerance

(Factory Calibration)

≤ ±5%

Reset Time

≤ 150ms

Initiate Time

≤ 20ms

Time Delay vs Temp.

& Voltage

≤ ±10%

Input

Voltage

24, 120, or 230VAC

Tolerance

±20%

AC Line Frequency

50/60 Hz

Power Consumption

≤ 2VA

Output

Type

Solid state

Form

NO, closed during timing

Maximum Load Current

1A steady state, 10A inrush at 60°C

Off State Leakage Current

≈ 5mA @ 230VAC

Voltage Drop

≈ 2.5V @ 1A

Protection

Circuitry

Encapsulated

Dielectric Breakdown

≥ 2000V RMS terminals to mounting surface

Insulation Resistance

≥ 100 MΩ

Mechanical

Mounting

Surface mount with one #10 (M5 x 0.8) screw

Dimensions

H 50.8 mm (2.0"); **W** 50.8 mm (2.0");

D 30.7 mm (1.21")

Termination

Environmental

Operating/Storage

Temperature

- 40° to 75°C / - 40° to 85°C

Humidity

95% relative, non-condensing

Weight

≈ 2.4 oz (68 g)

ERDI SERIES

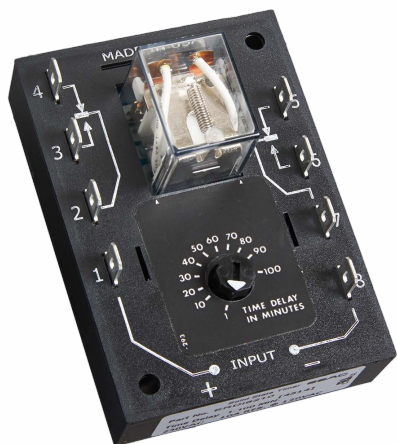

Description

Econo-Timers are a combination of digital electronics and an electromechanical relay. DPDT relay output for relay logic circuits, and isolation of input to output voltages. For applications, such as interval on, pulse shaping, minimum run time, etc. The ERD Series is encapsulated to protect the circuitry from shock, vibration and humidity.

Operation (Interval)

Upon application of input voltage, time delay begins, and output relay energizes. At the end of time delay, output de-energizes until input voltage is removed.

Reset: Removing input voltage resets the time delay and the output.

Operation (Single Shot)

Input voltage must be applied before and during timing. Upon momentary or maintained closure of initiate switch, output relay energizes for time delay. At the end of the delay, output de-energizes. Opening or reclosing initiate switch during timing has no affect on time delay. Output will energize if initiate switch is closed when input voltage is applied.

Reset: Reset occurs when time delay is complete & initiate switch is opened. Loss of input voltage resets time delay and output.

Wiring Diagram

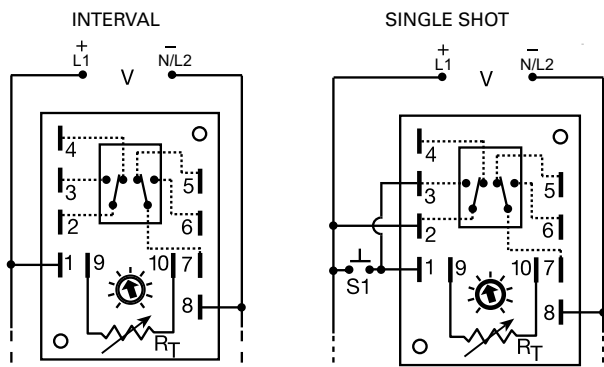

2-3 & 7-6 are Normally Open Contacts (NO)
2-4 & 7-5 are Normally Closed Contacts (NC)

Features & Benefits

FEATURES	BENEFITS
Digital integrated circuitry	Repeat Accuracy +/- 0.5%, Factory calibration +/- 10%
Isolated, 10A, DPDT output contacts	Allows control of loads for AC or DC voltages
Encapsulated	Protects against shock, vibration, and humidity

Accessories



P1004-16, P1004-16-X Versa-Pot
Panel mountable, industrial potentiometer recommended for remote time delay adjustment.



P0700-7 Versa-Knob
Designed for 0.25 in (6.35 mm) shaft of Versa-Pot. Semi-gloss industrial black finish.



P1015-64 (AWG 14/16) Female Quick Connect
These 0.25 in. (6.35 mm) female terminals are constructed with an insulator barrel to provide strain relief.



P1015-18 Quick Connect to Screw Adapter
Screw adapter terminal designed for use with all modules with 0.25 in. (6.35 mm) male quick connect terminals.

For dimensional drawing see: Appendix, page 512, Figure 25.

Ordering Information

MODEL	INPUT VOLTAGE	ADJUSTMENT	TIME DELAY
ERDI436	120VAC	External	0.6 - 60s
ERDI6210	230VAC	Onboard	1 - 100m

If you don't find the part you need, call us for a custom product 800-843-8848

ERDI SERIES

Selection Guides

RT Selection Chart						
Desired Time Delay*						RT Megohm
Seconds						
1	2	3	4	5	6	
0.1	0.1	0.1	0.2	0.3	0.6	0.0
0.19	0.6	1	1.7	3	6	0.1
0.28	1.1	2	3.2	6	12	0.2
0.37	1.6	3	4.7	9	18	0.3
0.46	2.1	4	6.2	12	24	0.4
0.55	2.6	5	7.7	15	30	0.5
0.64	3.0	6	9.2	18	36	0.6
0.73	3.5	7	10.7	21	42	0.7
0.82	4.0	8	12.2	24	48	0.8
0.91	4.5	9	13.7	27	54	0.9
1.0	5.0	10	15	30	60	1.0

* When selecting an external RT add at least 20% for tolerance of unit and the RT.

RT Selection Chart					
Desired Time Delay*					RT Megohm
Minutes					
7	8	9	10	11	
0.1	0.1	0.2	1	10	0.0
0.6	1	1.7	10	50	0.1
1.1	2	3.2	20	100	0.2
1.6	3	4.7	30	150	0.3
2.1	4	6.2	40	200	0.4
2.6	5	7.7	50	250	0.5
3.0	6	9.2	60	300	0.6
3.5	7	10.7	70	350	0.7
4.0	8	12.2	80	400	0.8
4.5	9	13.7	90	450	0.9
5.0	10	15	100	500	1.0

* When selecting an external RT add at least 20% for tolerance of unit and the RT.

Function Diagrams

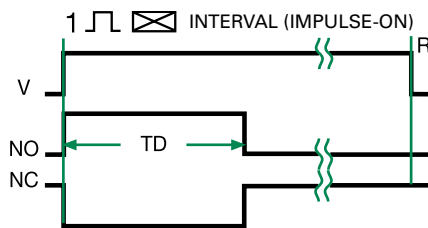

V = Voltage
NO = Normally Open Contact
NC = Normally Closed Contact
TD = Time Delay
R = Reset
— = Undefined Time

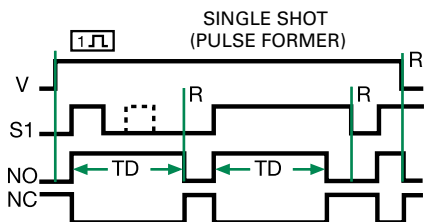

V = Voltage
S1 = Initiate Switch
NO = Normally Open Contact
NC = Normally Closed Contact
TD = Time Delay
R = Reset

Specifications

Time Delay

Type

Digital integrated circuitry
0.1s - 500m in 11 adjustable ranges,
0.1s - 1000m fixed

Range

External adjust or onboard

Adjustment

Repeat Accuracy

±0.5%

Tolerance

(Factory Calibration)

≤ ±10%

Reset Time

≤ 150ms

Time Delay vs Temp. & Voltage

≤ ±2%

Input

Voltage

120VAC or 230VAC

Tolerance

12VDC & 24VDC/AC

-15% - 20%

120VDC/AC & 230VAC

-20% - 10%

AC Line Frequency

50/60 Hz

Output

Type

Isolated relay contacts

Form

DPDT

Rating

10A resistive @ 120/240VAC & 28VDC;

1/3 hp @ 120/240VAC

Mechanical - 1 x 10⁷; Electrical - 1 x 10⁶

Life

Protection

Isolation Voltage

≥ 1500V RMS input to output

Insulation Resistance

≥ 100 MΩ

Polarity

DC units are reverse polarity protected

Mechanical

Mounting

Surface mount with two #6 (M3.5 x 0.6)

screws

Dimensions

H 88.9 mm (3.5"); **W** 63.5 mm (2.5");

D 43.2 mm (1.7")

Termination

0.25 in. (6.35 mm) male quick connect

terminals

Environmental

Operating/Storage

-40° to 65°C / -40° to 85°C

Temperature

≈ 5.7 oz (162 g)

Weight

HRDI SERIES

Interval Timer



Wiring Diagram

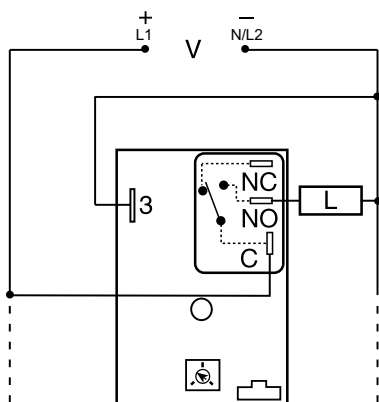

C = Common, Transfer Contact
NO = Normally Open
L = Load

NOTE: A knob, or terminals 4 & 5 are only included on adjustable units. R_T is used when external adjustment is ordered. Relay contacts are not isolated.

Description

The HRDI Series combines an electromechanical relay output with microcontroller timing circuitry. It offers 12 to 230V operation in five ranges and factory fixed, external, or onboard adjustable time delays with a repeat accuracy of ±0.5%. The output contact rating allows for direct operation of heavy loads, such as compressors, pumps, blower motors, heaters, etc. This series is ideal for OEM applications where cost is a factor.

Operation (Interval)

Upon application of input voltage, the time delay begins. The output relay is energized during the time delay. At the end of the time delay, the output de-energizes and remains de-energized until input voltage is removed.

Reset: Removing input voltage resets the time delay and the output.

Features & Benefits

FEATURES	BENEFITS
Microcontroller based	Repeat Accuracy +/- 0.5%
Compact, low cost design	Allows flexibility for OEM applications
Isolated, 30A, SPDT, NO output contacts	Allows direct operation of heavy loads: compressors, pumps, blower motors, heaters.
Encapsulated	Protects against shock, vibration, and humidity.

Accessories



P1004-95, P1004-95-X Versa-Pot
Panel mountable, industrial potentiometer recommended for remote time delay adjustment.



P1023-6 Mounting bracket
The 90° orientation of mounting slots makes installation/removal of modules quick and easy.



P0700-7 Versa-Knob
Designed for 0.25 in. (6.35 mm) shaft of Versa-Pot. Semi-gloss industrial black finish.



P1015-13 (AWG 10/12), P1015-64 (AWG 14/16) Female Quick Connect
These 0.25 in. (6.35 mm) female terminals are constructed with an insulator barrel to provide strain relief.



P1015-18 Quick Connect to Screw Adapter
Screw adapter terminal designed for use with all modules with 0.25 in. (6.35 mm) male quick connect terminals.



C103PM (AL) DIN Rail
35 mm aluminum DIN rail available in a 36 in. (91.4 cm) length.



P1023-20 DIN Rail Adapter
Allows module to be mounted on a 35 mm DIN type rail with two #10 screws.

For dimensional drawing see: Appendix, page 512, Figure 17.

Ordering Information

MODEL	INPUT VOLTAGE	ADJUSTMENT	TIME DELAY
HRDI117S	12VDC	Fixed	7s
HRDI421	120VAC	Onboard	1 - 100s
HRDI422	120VAC	Onboard	10 - 1000s

If you don't find the part you need, call us for a custom product 800-843-8848

HRDI SERIES

External Resistance vs. Time Delay

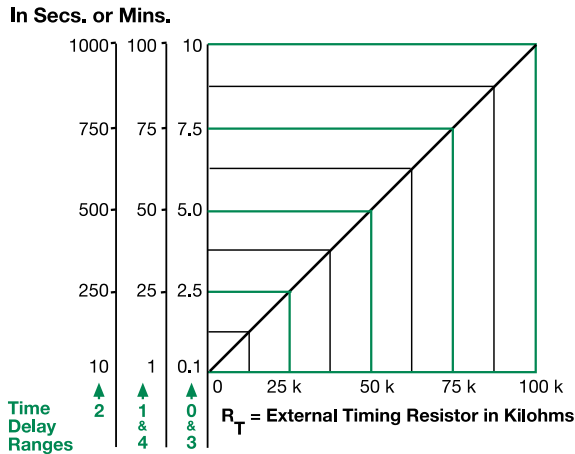

This chart applies to externally adjustable part numbers. The time delay is adjustable over the time delay range selected by varying the resistance across the R_T terminals; as the resistance increases the time delay increases. When selecting an external R_T, add the tolerances of the timer and the R_T for the full time range adjustment. **Examples:** 1 to 50 S adjustable time delay, select time delay range 1 and a 50 K ohm R_T. For 1 to 100 S use a 100 K ohm R_T.

Function Diagram

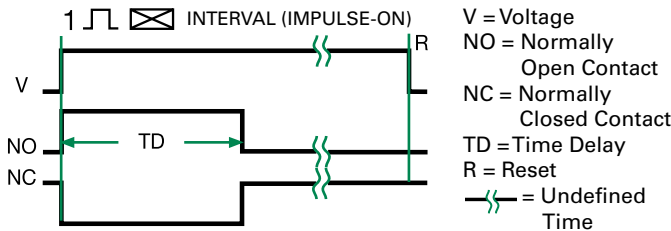

Specifications

Time Delay Type	Microcontroller circuitry	
Range	0.1s - 100m in 5 adjustable ranges or fixed	
Repeat Accuracy	±0.5 % or 20ms, whichever is greater	
Tolerance (Factory Calibration)	±1%, ±5%	
Recycle Time	≤ 150ms	
Time Delay vs Temp. & Voltage	±2%	
Input Voltage	12 or 24VDC; 24, 120, or 230VAC	
Tolerance 12VDC & 24VDC	-15% - 20%	
24 to 230VAC	-20% - 10%	
AC Line Frequency	50/60 Hz	
Power Consumption	AC ≤ 4VA; DC ≤ 2W	
Output Type	Electromechanical relay	
Form	SPDT, non-isolated	
Ratings	SPDT-NO	SPDT-NC
General Purpose	125/240VAC	15A
Resistive	125/240VAC	15A
	28VDC	10A
Motor Load	125VAC	1 hp*
	240VAC	2 hp**
Life	Mechanical - 1 x 10 ⁶ ; Electrical - 1 x 10 ⁵ , *3 x 10 ⁴ , **6,000	
Protection	IEEE C62.41-1991 Level A	
Surge Circuitry	Encapsulated	
Dielectric Breakdown	≥ 2000V RMS terminals to mounting surface	
Insulation Resistance	≥ 100 MΩ	
Polarity	DC units are reverse polarity protected	
Mechanical Mounting	Surface mount with one #10 (M5 x 0.8) screw	
Dimensions	H 76.7 mm (3"); W 51.3 mm (2"); D 38.1 mm (1.5")	
Termination	0.25 in. (6.35 mm) male quick connect terminals	
Environmental		
Operating/Storage Temperature	-40° to 60°C / -40° to 85°C	
Humidity	95% relative, non-condensing	
Weight	≈ 3.9 oz (111 g)	

KRDI SERIES



Description

The KRDI Series is a compact time-delay relay measuring only 2 in. (50.8 mm) square. Its solid-state timing circuit provides excellent repeat accuracy and stability. Encapsulation protects against shock, vibration, and humidity. The KRDI Series is a cost effective approach for OEM applications that require small size, isolation, reliability, and long life.

Operation (Interval)

Upon application of input voltage, the time delay begins. The output relay energizes during the time delay. At the end of the time delay, the output de-energizes and remains de-energized until input voltage is removed.

Reset: Removing input voltage resets the time delay and the output.

Wiring Diagram

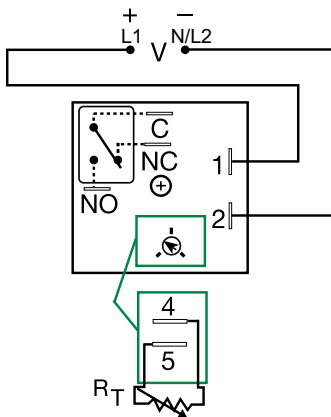

V = Voltage
C = Common, Transfer Contact
NO = Normally Open
NC = Normally Closed

A knob is supplied for adjustable units, or R_T terminals 4 & 5 for external adjust. See external adjustment vs time delay chart.

Relay contacts are isolated.

For dimensional drawing see: Appendix, page 512, Figure 16.

Features & Benefits

FEATURES	BENEFITS
Compact, low cost design measuring 2 in. (50.8mm) square	Allows flexibility for OEM applications
Microcontroller based	Repeat Accuracy +/- 0.5%, Factory calibration +/- 5%
Isolated, 10A, SPDT output contacts	Allows control of loads for AC or DC voltages
Encapsulated	Protects against shock, vibration, and humidity

Accessories



P1004-95, P1004-95-X Versa-Pot

Panel mountable, industrial potentiometer recommended for remote time delay adjustment.



P1023-6 Mounting bracket

The 90° orientation of mounting slots makes installation/removal of modules quick and easy.



P0700-7 Versa-Knob

Designed for 0.25 in. (6.35 mm) shaft of Versa-Pot. Semi-gloss industrial black finish.



P1015-13 (AWG 10/12), P1015-64 (AWG 14/16) Female Quick Connect

These 0.25 in. (6.35 mm) female terminals are constructed with an insulator barrel to provide strain relief.



P1015-18 Quick Connect to Screw Adapter

Screw adapter terminal designed for use with all modules with 0.25 in. (6.35 mm) male quick connect terminals.

Ordering Information

MODEL	INPUT VOLTAGE	ADJUSTMENT	TIME DELAY
KRDI120	12VDC	Onboard knob	0.1 - 10s
KRDI121	12VDC	Onboard knob	1 - 100s
KRDI122	12VDC	Onboard knob	10 - 1000s
KRDI2110S	24VAC/VDC	Fixed	10s
KRDI2160S	24VAC/VDC	Fixed	60s
KRDI220	24VAC/VDC	Onboard knob	0.1 - 10s
KRDI320	24VDC	Onboard knob	0.1 - 10s
KRDI420	120VAC	Onboard knob	0.1 - 10s
KRDI424	120VAC	Onboard knob	1 - 100m

If you don't find the part you need, call us for a custom product 800-843-8848

KRDI SERIES

Accessories



C103PM (AL) DIN Rail
35 mm aluminum DIN rail available in a 36 in. (91.4 cm) length.

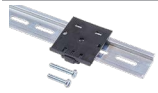

P1023-20 DIN Rail Adapter
Allows module to be mounted on a 35 mm DIN type rail with two #10 screws.

Specifications

Time Delay

Range	0.1s - 100m in 5 adjustable ranges or fixed
Repeat Accuracy	±0.5% or 20ms, whichever is greater
Tolerance	
(Factory Calibration)	≤ ± 5%
Reset Time	≤ 150ms
Time Delay vs Temp. & Voltage	≤ ±5%

Input

Voltage	12, 24 or 110VDC; 24, 120 or 230VAC
Tolerance	
12VDC & 24VDC/AC	-15% - 20%
110VDC, 120VAC or 230VAC	-20% - 10%
AC Line Frequency/DC Ripple	50/60 Hz / ≤ 10%
Power Consumption	AC ≤ 2VA; DC ≤ 2W

Output

Type	Isolated relay contacts
Form	SPDT
Rating (at 40°C)	10A resistive @ 125VAC; 5A resistive @ 230VAC & 28VDC; 1/4 hp @ 125VAC
Max. Switching Voltage	250VAC
Life (Operations)	Mechanical - 1×10^7 ; Electrical - 1×10^5

Protection

Circuitry	Encapsulated
Isolation Voltage	≥ 1500V RMS input to output
Insulation Resistance	≥ 100 MΩ
Polarity	DC units are reverse polarity protected

Mechanical

Mounting	Surface mount with one #10 (M5 x 0.8) screw
Dimensions	H 50.8 mm (2"); W 50.8 mm (2"); D 30.7 mm (1.21")
Termination	0.25 in. (6.35 mm) male quick connect terminals

Environmental

Operating/Storage Temperature	-20° to 60°C / -40° to 85°C
Humidity	95% relative, non-condensing
Weight	≈ 2.6 oz (74 g)

External Resistance vs. Time Delay

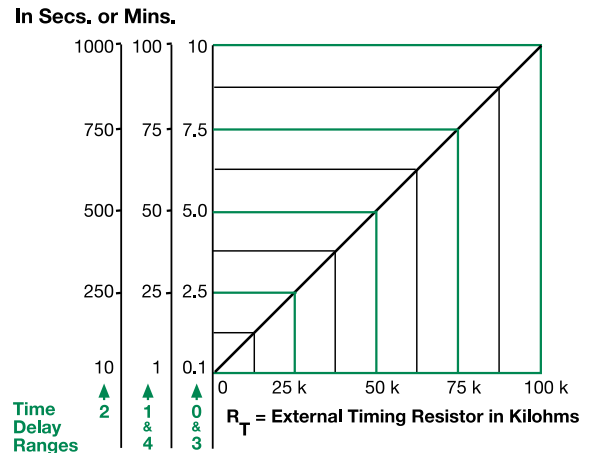

This chart applies to externally adjustable part numbers. The time delay is adjustable over the time delay range selected by varying the resistance across the RT terminals; as the resistance increases the time delay increases. When selecting an external R_T, add the tolerances of the timer and the RT for the full time range adjustment. **Examples:** 1 to 50 S adjustable time delay, select time delay range 1 and a 50 K ohm R_T. For 1 to 100 S use a 100 K ohm R_T.

Output Current/Ambient Temperature

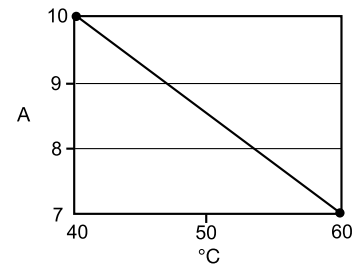

Function Diagram

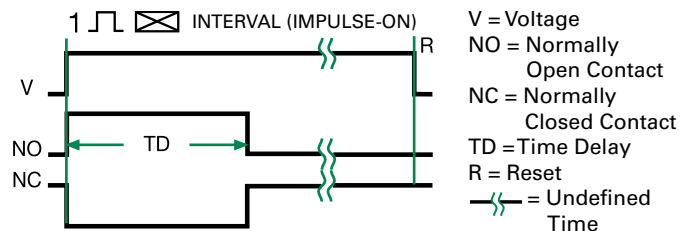

KSD2 SERIES

Interval Timer

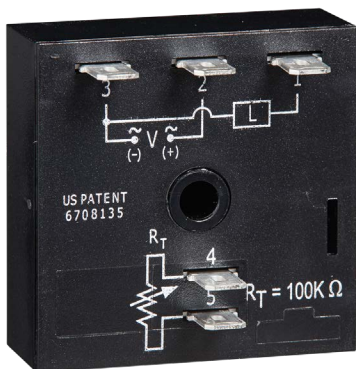

Wiring Diagram

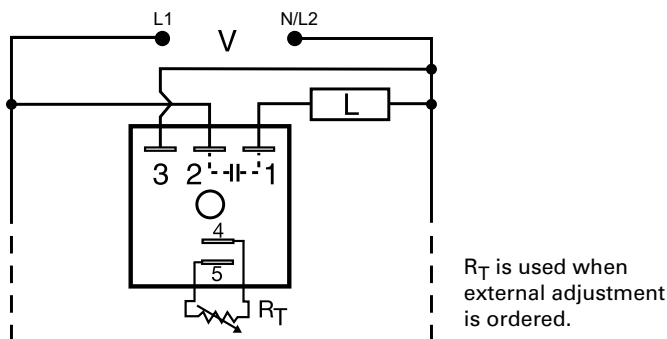

Description

The KSD2 Series is designed for general purpose commercial and industrial applications where a small, cost effective, reliable, solid-state timer is required. The factory calibration for fixed time delays is within 5% of the target time delay. The repeat accuracy, under stable conditions, is 0.5% of the selected time delay. This series is designed for input voltages of 24, 120 or 230VAC. Time delays of 0.1 seconds to 1000 minutes are available in 6 ranges. The output is rated 1A steady and 10A inrush. The modules are totally solid state and encapsulated to protect the electronic circuitry. An excellent choice for most OEM pulse shaping, maximum run time, and other process control applications.

Operation (Interval)

Upon application of input voltage, the time delay begins. The output energizes during the time delay. At the end of the time delay, the output de-energizes and remains de-energized until input voltage is removed.

Reset: Removing input voltage resets the time delay and the output.

Features & Benefits

FEATURES	BENEFITS
Microcontroller based	Repeat Accuracy +/- 0.5%, +/- 5% time delay accuracy
Compact, low cost design	Allows flexibility for OEM applications
1A Steady solid-state output, 10A inrush	Provides 100 million operations in typical conditions.
Totally solid state and encapsulated	No moving parts to arc and wear out over time and encapsulated to protect against shock, vibration, and humidity

Accessories



P1004-95, P1004-95-X Versa-Pot
Panel mountable, industrial potentiometer recommended for remote time delay adjustment.



P1023-6 Mounting bracket
The 90° orientation of mounting slots makes installation/removal of modules quick and easy.



P0700-7 Versa-Knob
Designed for 0.25 in (6.35 mm) shaft of Versa-Pot. Semi-gloss industrial black finish.



P1015-64 (AWG 14/16) Female Quick Connect
These 0.25 in. (6.35 mm) female terminals are constructed with an insulator barrel to provide strain relief.

Ordering Information

MODEL	INPUT VOLTAGE VAC	ADJUSTMENT	TIME DELAY
KSD2221	24	External	1 - 100s
KSD2413M	120	Fixed	3m
KSD2420	120	External	0.1 - 10s

If you don't find the part you need, call us for a custom product 800-843-8848

For dimensional drawing see: Appendix, page 512, Figure 16.

KSD2 SERIES

Accessories



P1015-18 Quick Connect to Screw Adapter
Screw adapter terminal designed for use with all modules with 0.25 in. (6.35 mm) male quick connect terminals.



C103PM (AL) DIN Rail
35 mm aluminum DIN rail available in a 36 in. (91.4 cm) length.

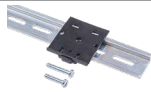

P1023-20 DIN Rail Adapter
Allows module to be mounted on a 35 mm DIN type rail with two #10 screws.

External Resistance vs. Time Delay

In Secs. or Mins.

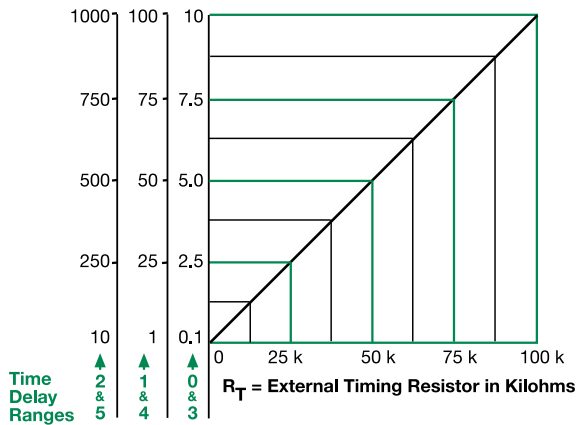

This chart applies to externally adjustable part numbers.

The time delay is adjustable over the time delay range selected by varying the resistance across the R_T terminals; as the resistance increases the time delay increases.

When selecting an external R_T , add the tolerances of the timer and the R_T for the full time range adjustment.

Examples: 1 to 50 S adjustable time delay, select time delay range 1 and a 50 K ohm R_T . For 1 to 100 S use a 100 K ohm R_T .

Function Diagram

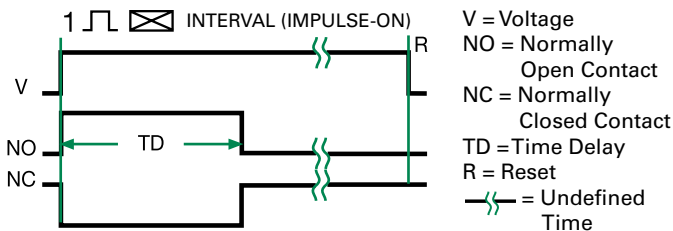

Specifications

Time Delay

Range

0.1s - 1000m in 6 adjustable ranges or fixed

Repeat Accuracy

±0.5% or 20ms, whichever is greater

Tolerance

(Factory Calibration)

≤ ±5%

Reset Time

≤ 150ms

Time Delay vs. Temperature

& Voltage

≤ ±10%

Input

Voltage

24, 120, or 230VAC

Tolerance

±20%

AC Line Frequency

50/60 Hz

Power Consumption

≤ 2VA

Output

Type

Solid state

Form

NO, closed during timing

Maximum Load Current

1A steady state, 10A inrush at 60°C

OFF State Leakage Current

≈ 5mA @ 230VAC

Voltage Drop

≈ 2.5V @ 1A

Protection

Encapsulated

Dielectric Breakdown

≥ 2000V RMS terminals to mounting surface

Insulation Resistance

≥ 100 MΩ

Mechanical

Mounting

Surface mount with one #10 (M5 x 0.8) screw

Dimensions

H 50.8 mm (2"); **W** 50.8 mm (2");

D 30.7 mm (1.21")

Termination

0.25 in. (6.35 mm) male quick connect terminals

Environmental

Operating/Storage

Temperature

-40° to 60°C / -40° to 85°C

Humidity

95% relative, non-condensing

Weight

≈ 2.4 oz (68 g)

KSPU SERIES

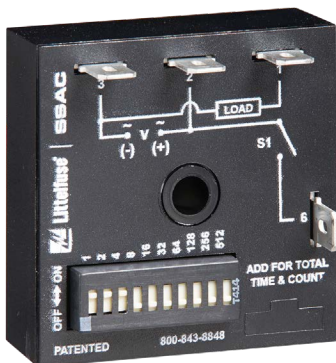

Description

The KSPU Series is a factory programmed module available in any 1 of 14 standard functions. The KSPU offers a single adjustable timer or counter function. Switch adjustment allows accurate selection of the time delay or number of counts the first time and every time. The 1A steady, 10A inrush rated solid-state output provides 100 million operations, typical. Its microcontroller timing circuit provides excellent repeat accuracy and stability. Encapsulation protects against shock, vibration, and humidity. The KSPU Series is a cost effective approach for OEM applications that require small size, solid state reliability, and accurate switch adjustment.

Features & Benefits

FEATURES	BENEFITS
Microcontroller based	Repeat Accuracy + / - 0.1%
Compact design	Allows flexibility for OEM applications
1A steady, 10A inrush solid-state output	Provides 100 million operations in typical conditions.
Totally solid state and encapsulated	No moving parts to arc and wear out over time and encapsulated to protect against shock, vibration, and humidity

Wiring Diagram

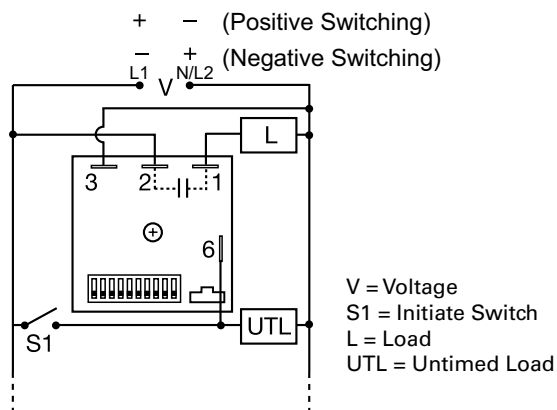

For dimensional drawing see: Appendix, page 512, Figure 16.

Accessories

- 
P1015-64 (AWG 14/16), P1015-14 (AWG 18/22) Female Quick Connect
 These 0.25 in. (6.35 mm) female terminals are constructed with an insulator barrel to provide strain relief.
- 
P1015-18 Quick Connect to Screw Adapter
 Screw adapter terminal designed for use with all modules with 0.25 in. (6.35 mm) male quick connect terminals.
- 
C103PM (AL) DIN Rail
 35 mm aluminum DIN rail available in a 36 in. (91.4 cm) length.
- 
P1023-20 DIN Rail Adapter
 Allows module to be mounted on a 35 mm DIN type rail with two #10 screws.

Ordering Information

MODEL	INPUT VOLTAGE	TIME DELAY/COUNTS	FUNCTION
KSPUA2I	24 to 240VAC	1 - 1023s	Interval
KSPUA8C	24 to 240VAC	1 - 1023 counts (binary) with pulsed output	Counter with pulsed output

If you don't find the part you need, call us for a custom product 800-843-8848

KSPU SERIES

Specifications

Time Delay

Range* 0.1 - 102.3s, m or h in 0.1s, m or h increments
 1 - 1023s, m or h in 1s, m or h increments
 1 - 63s or m in 1s or m increments

Repeat Accuracy ±0.1% or 20 ms, whichever is greater
Setting Accuracy ≤ ±1% or 20 ms, whichever is greater

Reset Time ≤ 150ms

Initiate Time ≤ 20ms

Time Delay vs. Temperature & Voltage ≤ ±2%

Input

Voltage/Tolerance 24 to 240VAC, 12 to 120VDC/≤ ±15%

AC Line Frequency/DC Ripple 50/60 Hz/≤ 10%

Power Consumption AC ≤ 2VA; DC ≤ 1W

Output

Type Solid state

Form NO, SPST-NO

Rating 1A steady state, 10A inrush for 16ms

Voltage Drop AC ≅ 2.5V @ 1A; DC ≅ 1V @ 1A

Off State Leakage Current AC ≅ 5mA @ 240VAC; DC ≅ 1 mA

Counter Output Output pulse width: 300ms ±20%
 Time Delay/Counts Variable 7 & 8

Protection

Circuitry Encapsulated

Dielectric Breakdown ≥ 2000V RMS terminals to mounting surface

Insulation Resistance ≥ 100 MΩ

Polarity DC units are reverse polarity protected

Mechanical

Mounting Surface mount with one #10 (M5 x 0.8) screw

Dimensions **H** 50.8 mm (2"); **W** 50.8 mm (2");
D 30.7 mm (1.21")

0.25 in. (6.35 mm) male quick connect terminals

Termination

Environmental

Operating/Storage

Temperature -40° to 60°C / -40° to 85°C

Humidity 95% relative, non-condensing

Weight ≅ 2.4 oz (68 g)

*For CE approved applications, power must be removed from the unit when a switch position is changed.

Adjustment Switch Operation

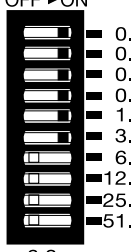
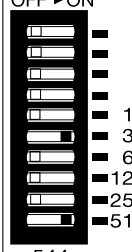
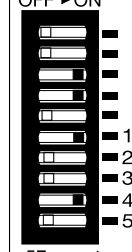
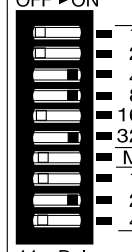
TIME DELAY		COUNTER	
0.1...102.3	1...1023	1...165	1...63
OFF ▶ ON	OFF ▶ ON	OFF ▶ ON	OFF ▶ ON
 0.1 0.2 0.4 0.8 1.6 3.2 6.4 12.8 25.6 51.2 6.3	 1 2 4 8 16 32 64 128 256 512 544	 1 2 3 4 5 10 20 30 40 50 57 counts	 1 2 4 8 16 32 M* 1 2 4 44 s Delay 2 counts to Start

* for selecting time in minutes or seconds

Function Diagrams

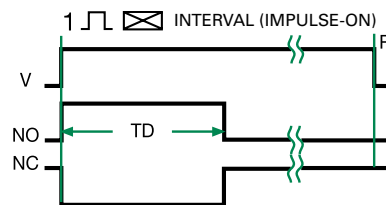
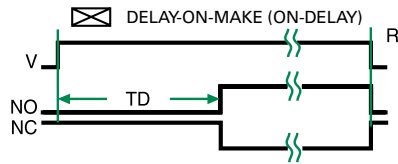

V = Voltage
 NO = Normally Open Contact
 NC = Normally Closed Contact
 TD = Time Delay
 R = Reset
 = Undefined Time

TDI / TDIH / TDIL SERIES



8-PIN

Wiring Diagram

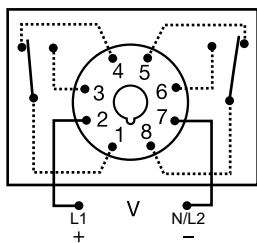

Relay contacts are isolated.

For dimensional drawing see: Appendix, page 512, Figure 23.

Ordering Information

MODEL	INPUT VOLTAGE	TIME DELAY	LED
TDI120AL	120VAC	1 - 1023s in 1s increments	Yes
TDI12D	12VDC	1 - 1023s in 1s increments	No
TDIH24AL	24VAC	10 - 10,230s in 10s increments	Yes
TDIL120AL	120VAC	0.1 - 102.3s in 0.1s increments	Yes
TDIL24DL	24VDC	0.1 - 102.3s in 0.1s increments	Yes

If you don't find the part you need, call us for a custom product 800-843-8848

Description

The TDI Series is an interval timer that combines accurate digital circuitry with isolated, 10A rated, DPDT relay contacts in an 8-pin plug-in package. The TDI Series features DIP switch selectable time delays ranging from 0.1 to 10,230 seconds in three ranges. The TDI Series is the product of choice for custom control panel and OEM designers.

Operation (Interval)

Upon application of input voltage, the time delay begins. The output relay is energized during the time delay. At the end of the time delay, the output de-energizes and remains de-energized until input voltage is removed.

Reset: Removing input voltage resets the time delay and the output.

Features & Benefits

FEATURES	BENEFITS
Digital circuitry	Repeat Accuracy +/- 0.1%, Setting accuracy +/- 2%
Isolated, 10A, DPDT output contacts	Allows control of loads for AC or DC voltages
DIP switch adjustment	Provides first time setting accuracy
Industry standard octal plug connection	Eliminates need for special connectors
LED indication	Provides visual indication of timing and output status

Accessories



BZ1 Front Panel Mount Kit

Provides an easy method of through-the-panel mounting of 8- or 11-pin plug-in timers, flashers, and other controls.



NDS-8 Octal 8-pin Socket

8-pin 35mm DIN rail or surface mount. Surface mounted with two #6 (M 3.5 x 0.6) screws or snaps onto a 35 mm DIN rail. Uses PSC8 hold-down clips.



PSC8 Hold-down Clips

Securely mounts plug-in controls in any position. Provides protection against vibration. Use with NDS-8 Octal Socket. Sold in pairs.



C103PM (AL) DIN Rail

35 mm aluminum DIN rail available in a 36 in. (91.4 cm) length.

TDI / TDIH / TDIL SERIES

Specifications

Time Delay

Type	Digital integrated circuitry
Range**	0.1 - 102.3s in 0.1s increments 1 - 1023s in 1s increments 10 - 10,230s in 10s increments
Repeat Accuracy	±0.1% or 20ms, whichever is greater
Setting Accuracy	±2% or 50ms, whichever is greater
Reset Time	≤ 50ms
Recycle Time	≤ 150ms
Time Delay vs Temp. & Voltage	±2%
Indicator	LED glows during timing; relay is energized

Input

Voltage Tolerance	12, 24, or 110VDC; 24, 120, or 230VAC
12VDC & 24VDC/AC	-15% - +20%
110 to 230VAC/DC	-20% - +10%
AC Line Frequency	50/60 Hz
Power Consumption	≤ 3.25W

Output

Type	Electromechanical relay
Form	DPDT
Rating	10A resistive @ 120/240VAC & 28VDC; 1/3 hp @ 120/240VAC
Life	Mechanical - 1 x 10 ⁷ ; Electrical - 1 x 10 ⁶

Protection

Polarity	DC units are reverse polarity protected
Isolation Voltage	≥ 1500V RMS input to output

Mechanical

Mounting	Plug-in socket
Dimensions	H 81.3 mm (3.2"); W 60.7 mm (2.4"); D 45.2 mm (1.8")
Termination	Octal 8-pin plug-in

Environmental

Operating/Storage Temperature	-20° to 65°C / -30° to 85°C
Weight	≈ 6 oz (170 g)

** For CE approved applications, power must be removed from the unit when a switch position is changed.

Digi-Set Binary Switch Operation

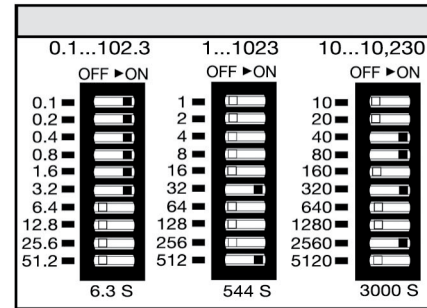

Function Diagram

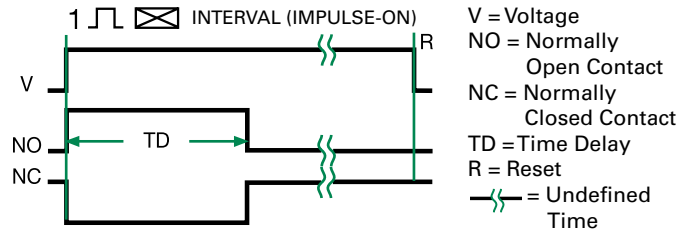

TDUI / TDUIH / TDUIL SERIES



Description

The TDUI Series combines digital timing circuitry with universal voltage operation. Voltages of 24 to 240VAC and 12 to 24VDC are available in three ranges. The TDUI Series offers DIP switch selectable time delays ranging from 0.1 seconds to 102.3 minutes in three ranges. Its 1A rated output, ability to operate on multiple voltages, and wide range of switch selectable time delays make the TDUI Series an excellent choice for process control systems and OEM equipment.

Operation (Interval)

Upon application of input voltage, the time delay begins. The output energizes during the time delay. At the end of the time delay, the output de-energizes and remains de-energized until input voltage is removed.

Reset: Removing input voltage resets the time delay and the output.

Wiring Diagram

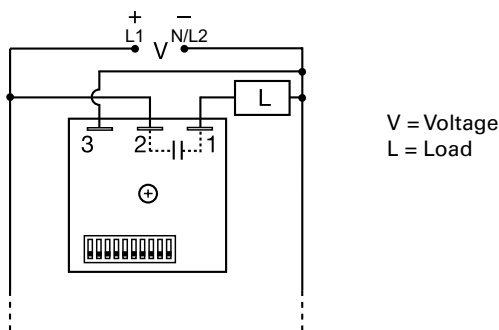

For dimensional drawing see: Appendix, page 512, Figure 16.

Features & Benefits

FEATURES	BENEFITS
Microcontroller based	Repeat Accuracy +/- 0.5%, Setting accuracy +/- 2%
Compact design	Allows flexibility for OEM applications
1A steady, 10A inrush solid-state output	Provides 100 million operations in typical conditions
Totally solid state and encapsulated	No moving parts to arc and wear out over time and encapsulated to protect against shock, vibration, and humidity
Wide voltage ranges	Flexibility to handle multiple voltages found in control systems and OEM applications
DIP switch Adjustment	Provides first time setting accuracy

Accessories

- 
P1015-13 (AWG 10/12), P1015-64 (AWG 14/16), P1015-14 (AWG 18/22) Female Quick Connect
 These 0.25 in. (6.35 mm) female terminals are constructed with an insulator barrel to provide strain relief.
- 
P1015-18 Quick Connect to Screw Adapter
 Screw adapter terminal designed for use with all modules with 0.25 in. (6.35 mm) male quick connect terminals.
- 
C103PM (AL) DIN Rail
 35 mm aluminum DIN rail available in a 36 in. (91.4 cm) length.
- 
P1023-20 DIN Rail Adapter
 Allows module to be mounted on a 35 mm DIN type rail with two #10 screws.

12

TIME DELAY RELAYS

Ordering Information

MODEL	INPUT VOLTAGE	TIME DELAY
TDUI3000A	24 to 120VAC	1 - 102.3s
TDUIH3002A	12 to 24VDC	0.1 - 102.3m
TDUIL3001A	100 to 240VAC	0.1 - 102.3s
TDUIL3002A	12 to 24VDC	0.1 - 102.3s

If you don't find the part you need, call us for a custom product 800-843-8848

TDUI / TDUIH / TDUIL SERIES

Specifications

Time Delay

Range*	0.1 - 102.3s in 0.1s increments 1 - 1023s in 1s increments 0.1 - 102.3m in 0.1m increments
Repeat Accuracy	±0.5% or 20ms, whichever is greater
Setting Accuracy	≤ ±2% or 20ms, whichever is greater
Reset Time	≤ 150ms

Time Delay vs Temp. & Voltage

≤ ±5%

Input

Voltage 24 to 240VAC, 12 to 24VDC ±20%

AC Line Frequency 50/60 Hz

Power Consumption AC ≤ 2VA; DC ≤ 1W

DC Ripple ≤ 10%

Output

Type Solid state

Form NO, closed during timing

Rating 1A steady state, 10A inrush at 60°C

Voltage Drop AC ≈ 2.5V @ 1A; DC ≈ 1V @ 1A

OFF State Leakage Current AC ≈ 5mA @ 230VAC; DC ≈ 1mA

Protection

Circuitry Encapsulated

Dielectric Breakdown ≥ 2000V RMS terminals to mounting surface

Insulation Resistance ≥ 100 MΩ

Polarity DC units are reverse polarity protected

Mechanical

Mounting Surface mount with one #10 (M5 x 0.8) screw

Dimensions **H** 50.8 mm (2"); **W** 50.8 mm (2");

D 30.7 mm (1.21")

0.25 in. (6.35 mm) male quick connect terminals

Environmental

Operating/Storage

Temperature -40° to 60°C / -40° to 85°C

Humidity 95% relative, non-condensing

Weight ≈ 2.4 oz (68 g)

Switch Operation

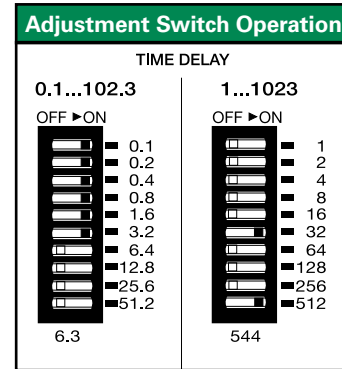

Function Diagram

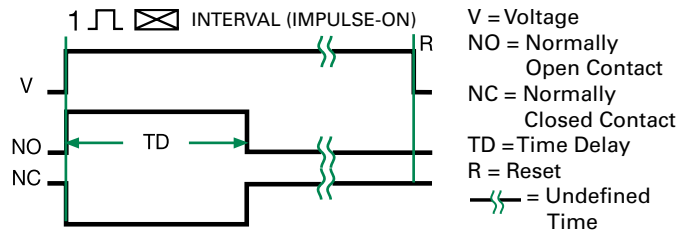

*For CE approved applications, power must be removed from the unit when a switch position is changed.

THD2 SERIES

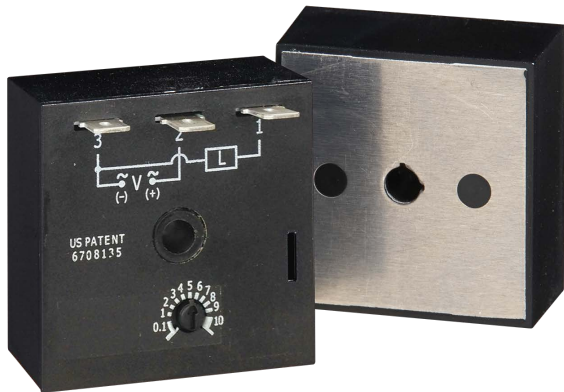

Wiring Diagram

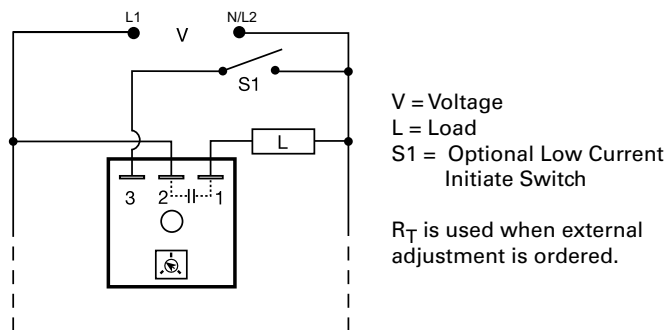

For dimensional drawing see: Appendix, page 512, Figure 19.

Description

The THD2 Series combines accurate timing circuitry with high power solid-state switching. It can switch motors, lamps, and heaters directly without a contactor. You can reduce labor, component cost, and increase reliability with these small, easy-to-use, Digi-Power timers.

Operation (Interval)

Upon application of input voltage, the time delay begins. The output energizes during the time delay. At the end of the time delay, the output de-energizes and remains de-energized until input voltage is removed.

Reset: Removing input voltage resets the time delay and the output.

Features & Benefits

FEATURES	BENEFITS
Microcontroller based	Repeat Accuracy +/- 0.5%, Factory calibration +/- 1%
High load currents up to 20A, 200A inrush	Allows direct control of motors, lamps and heaters without a contactor
Totally solid state and encapsulated	No moving parts to arc and wear out over time and encapsulated to protect against shock, vibration, and humidity
Metalized mounting surface	Facilitates heat transfer in high current applications
Compact, low cost design	Allows flexibility for OEM applications and reduces labor and components costs

Accessories



P1004-95, P1004-95-X Versa-Pot
Panel mountable, industrial potentiometer recommended for remote time delay adjustment.



P0700-7 Versa-Knob
Designed for 0.25 in (6.35 mm) shaft of Versa-Pot. Semi-gloss industrial black finish.



P1015-13 (AWG 10/12), P1015-64 (AWG 14/16) Female Quick Connect
These 0.25 in. (6.35 mm) female terminals are constructed with an insulator barrel to provide strain relief.



P1015-18 Quick Connect to Screw Adapter
Screw adapter terminal designed for use with all modules with 0.25 in. (6.35 mm) male quick connect terminals.

Ordering Information

MODEL	OUTPUT RATING	INPUT VOLTAGE	ADJUSTMENT	TIME DELAY
THD2C420	20A	120VAC	External	0.1 - 10s
THD2C423	20A	120VAC	External	0.1 - 10m
THD2C433	20A	120VAC	Onboard	0.1 - 10m
THD2C620	20A	230VAC	External	0.1 - 10s
THD2C633	20A	230VAC	Onboard	0.1 - 10m

If you don't find the part you need, call us for a custom product 800-843-8848

12

TIME DELAY RELAYS

THD2 SERIES

External Resistance vs. Time Delay

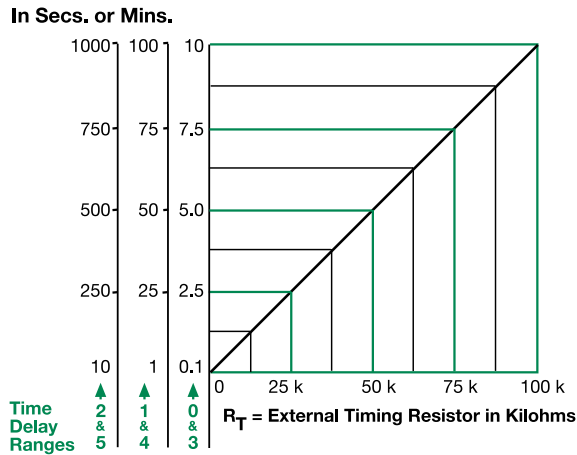

This chart applies to externally adjustable part numbers.
The time delay is adjustable over the time delay range selected by varying the resistance across the R_T terminals; as the resistance increases the time delay increases.

When selecting an external R_T , add the tolerances of the timer and the R_T for the full time range adjustment.

Examples: 1 to 50 S adjustable time delay, select time delay range 1 and a 50 K ohm R_T . For 1 to 100 S use a 100 K ohm R_T .

Function Diagram

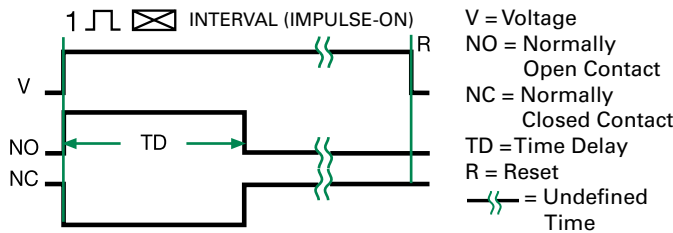

Specifications

Time Delay Range	0.1s - 1000ms in 6 adjustable ranges or fixed		
Repeat Accuracy	±0.5% or 20ms, whichever is greater		
Tolerance (Factory Calibration)	≤ ±1%		
Reset Time	≤ 150ms		
Time Delay vs Temp. & Voltage	≤ ±2%		
Input Voltage	24, 120, or 230VAC		
Tolerance	±20%		
AC Line Frequency	50/60 Hz		
Output Type	Solid state		
Form	NO, closed during timing		
Maximum Load Current	Output	Steady State	Inrush**
	A	6A	60A
	B	10A	100A
	C	20A	200A
Minimum Load Current	10mA		
Voltage Drop	≈ 2.5V at rated current		
OFF State Leakage Current	≈ 5mA @ 230VAC		
Protection Circuitry	Encapsulated		
Dielectric Breakdown	≥ 2000V RMS terminals to mounting surface		
Insulation Resistance	≥ 100 MΩ		
Mechanical Mounting**	Surface mount with one #10 (M5 x 0.8) screw		
Dimensions	H 50.8 mm (2"); W 50.8 mm (2"); D 38.4 mm (1.51")		
Termination	0.25 in. (6.35 mm) male quick connect terminals		
Environmental Operating/Storage Temperature	-40° to 60°C / -40° to 85°C		
Humidity	95% relative, non-condensing		
Weight	≈ 3.9 oz (111 g)		

**Must be bolted to a metal surface using the included heat sink compound. The maximum mounting surface temperature is 90°C. Inrush: Non-repetitive for 16ms.

THD7 SERIES

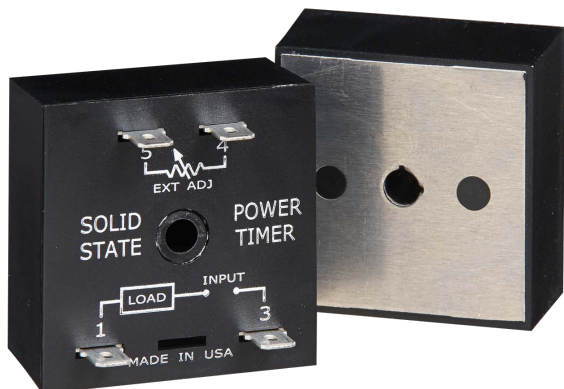

Wiring Diagram

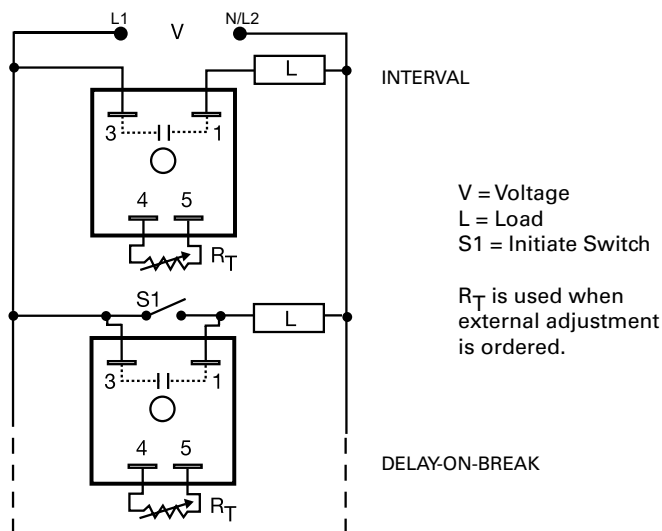

For dimensional drawing see: Appendix, page 512, Figure 19.

Ordering Information

MODEL	INPUT VOLTAGE	ADJUSTMENT	TIME DELAY	OUTPUT RATING
THD7421A	120VAC	External	1 - 100s	6A
THD7621C	230VAC	External	1 - 100s	20A

If you don't find the part you need, call us for a custom product 800-843-8848

Description

The THD7 Series utilizes only two terminals connected in series with the load. Interval timing mode is achieved by using a small portion of the AC sine wave allowing sufficient voltage for circuit operation. The THD7 Series can be used for interval or delay-on-break timing. It is designed to operate large loads directly, such as motors, heater elements, and motor starters.

Operation (Interval)

Upon application of input voltage, the output energizes and the time delay begins. The output remains energized throughout the time delay. At the end of the time delay the output de-energizes and remains de-energized until power is removed.

Reset: Removing input voltage resets the time delay and the output.

Operation (Delay-on-Break)

Upon closure of SW1, the load energizes and the timer is reset (zero voltage across its input terminals). Opening SW1 re-applies input voltage to the timer, the load remains energized and the time delay begins. At the end of the time delay the output de-energizes. If SW1 is open when power is applied, the load will energize for the time delay then de-energize.

Reset: Reclosing SW1 resets the timer.

Features & Benefits

FEATURES	BENEFITS
Digital integrated circuitry	Repeat Accuracy +/- 0.5%
High load currents up to 20A, 200A inrush	Allows direct operation of motors, lamps and heaters without a contactor
Totally solid state and encapsulated	No moving parts to arc and wear out over time and encapsulated to protect against shock, vibration and humidity
Metalized mounting surface	Facilitates heat transfer in high current applications
Compact, low cost design	Allows flexibility for OEM applications and reduces labor and component costs

Accessories



P1004-13, P1004-13-X Versa-Pot

Panel mountable, industrial potentiometer recommended for remote time delay adjustment.



P1023-6 Mounting bracket

The 90° orientation of mounting slots makes installation/removal of modules quick and easy.



P0700-7 Versa-Knob

Designed for 0.25 in. (6.35 mm) shaft of Versa-Pot. Semi-gloss industrial black finish.



P1015-13 (AWG 10/12), P1015-64 (AWG 14/16) Female Quick Connect

These 0.25 in. (6.35 mm) female terminals are constructed with an insulator barrel to provide strain relief.

THD7 SERIES

Accessories



P1015-18 Quick Connect to Screw Adapter
Screw adapter terminal designed for use with all modules with 0.25 in. (6.35 mm) male quick connect terminals.



C103PM (AL) DIN Rail
35 mm aluminum DIN rail available in a 36 in. (91.4 cm) length.

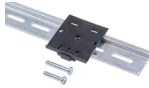

P1023-20 DIN Rail Adapter
Allows module to be mounted on a 35 mm DIN type rail with two #10 screws.



VTP(X)(X) Plug-on Adjustment Module
Mounts on modules with in-line adjustment terminals. Rated at 0.25W at 55°C. Available in resistance values from 5KΩ to 5MΩ.

Selection Table for VTP Plug-on Adjustment Accessory

Time Delay	VTP P/N
1 - 1-100s	VTP5G
2 - 10-1000s	VTP5K
3 - 0.1-10m	VTP5N
4 - 1-100m	VTP5P
5 - 10-1000m	VTP5R

Selection Guide

RT Selection Chart					
Desired Time Delay*					RT
Seconds		Minutes			
1	2	3	4	5	Megohm
1	10	0.1	1	10	0.0
10	100	1	10	100	0.5
20	200	2	20	200	1.0
30	300	3	30	300	1.5
40	400	4	40	400	2.0
50	500	5	50	500	2.5
60	600	6	60	600	3.0
70	700	7	70	700	3.5
80	800	8	80	800	4.0
90	900	9	90	900	4.5
100	1000	10	100	1000	5.0

* When selecting an external RT add at least 20% for tolerance of unit and the RT.

Specifications

Time Delay

Type Digital integrated circuitry
Range 1s - 1000m in 5 adjustable ranges or fixed
Repeat Accuracy ±0.5% or 20ms, whichever is greater
Tolerance (Factory Calibration) ≤ ±10%
Recycle Time After timing: ≤150ms; During timing: ≤ 350ms
Time Delay vs Temp. & Voltage ≤ ±2%

Input

Voltage 24, 120, or 230VAC
Tolerance ±20%
AC Line Frequency 50/60 Hz

Output

Type Solid state
Form NO, closed during timing
Rating

Output	Steady State	Inrush**
A	6A	60A
B	10A	100A
C	20A	200A

Effective Voltage Drop (VLine-VLoad)

Input	Effective Drop
24VAC	≤ 3V
120VAC	≤ 3V
230VAC	≤ 5V

Minimum Load Current

100mA

Protection

Circuitry Encapsulated
Dielectric Breakdown Insulation Resistance ≥ 2000V RMS terminals to mounting surface
 ≥ 100 MΩ

Mechanical

Mounting ** Surface mount with one #10 (M5 x 0.8) screw
Dimensions **H** 50.8 mm (2"); **W** 50.8 mm (2");
D 38.4 mm (1.51")
Termination 0.25 in. (6.35 mm) male quick connect terminals

Environmental

Operating/Storage Temperature -40° to 60°C / -40° to 85°C
Humidity 95% relative, non-condensing
Weight ≈ 3.9 oz (111 g)

**Must be bolted to a metal surface using the included heat sink compound. The maximum mounting surface temperature is 90°C. Inrush: Non-repetitive for 16ms.

Function Diagrams

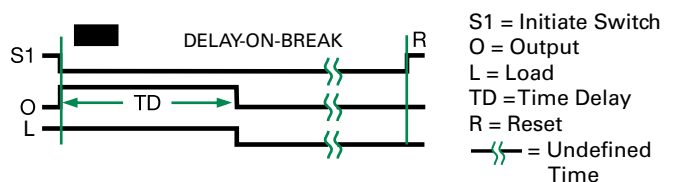
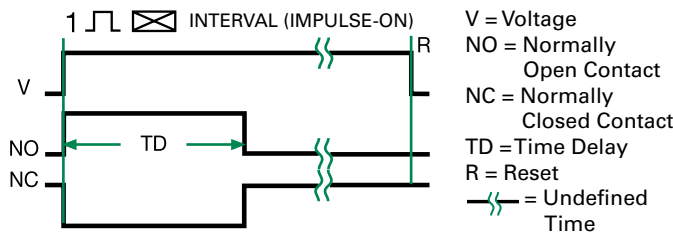

TS2 / TS6 SERIES



TS2



TS6

Description

The TS2 Series is designed for 24, 120 or 230VAC and the TS6 Series is designed for 12 or 24VDC. These series are capable of controlling load currents of up to 1A steady state, 10A inrush. Encapsulated circuitry and the reliability of a $\pm 2\%$ repeat accuracy make the TS2 and TS6 ideal for cost sensitive applications.

Operation (Interval)

Upon application of input voltage, the time delay begins. The output energizes during the time delay. At the end of the time delay, the output de-energizes and remains de-energized until input voltage is removed.

Reset: Removing input voltage resets the time delay and the output.

Wiring Diagram

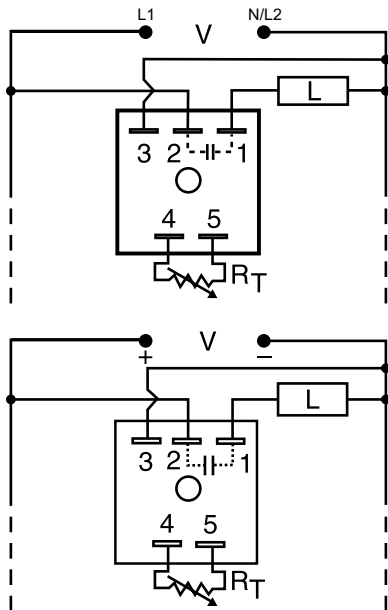

V = Voltage
L = Load

R_T is used when external adjustment is ordered.

Note: TS6 is not reverse polarity protected.

Features & Benefits

FEATURES	BENEFITS
Analog circuitry	Repeat accuracy $\pm 2\%$, Factory calibration $\pm 10\%$
Totally solid state and encapsulated	No moving parts to arc and wear out over time and encapsulated to protect against shock, vibration, and humidity
1A steady, 10A inrush solid-state output	Provides 100 million operations in typical conditions
Rated for operation up to 75°C	Can be used in the harshest environments

Accessories



P1004-XX (fig. A), **P1004-XX-X** (fig. B) **Versa-Pot**
Panel mountable, industrial potentiometer recommended for remote time delay adjustment.



P1023-6 Mounting bracket

The 90° orientation of mounting slots makes installation/removal of modules quick and easy.



P0700-7 Versa-Knob

Designed for 0.25 in (6.35 mm) shaft of Versa-Pot. Semi-gloss industrial black finish.

For dimensional drawing see: Appendix, page 512, Figure 16.

Ordering Information

MODEL	INPUT VOLTAGE	ADJUSTMENT	TIME DELAY	SWITCHING MODE	MODEL	INPUT VOLTAGE	ADJUSTMENT	TIME DELAY	SWITCHING MODE
TS22120	24VAC	Fixed	20s	n/a	TS2424	120VAC	External	5 - 600s	n/a
TS2223	24VAC	External	2 - 180s	n/a	TS6116P	12VDC	Fixed	6s	Positive
TS2412	120VAC	Fixed	2s	n/a	TS6122P	12VDC	External	0.5 - 20s	Positive
TS24130	120VAC	Fixed	30s	n/a	TS6123P	12VDC	External	2 - 60s	Positive
TS2421	120VAC	External	0.05 - 3s	n/a	TS6321P	24VDC	External	0.05 - 3s	Positive
TS2422	120VAC	External	0.5 - 60s	n/a	TS6323P	24VDC	External	2 - 180s	Positive
TS2423	120VAC	External	2 - 180s	n/a					

If you don't find the part you need, call us for a custom product 800-843-8848

12 TIME DELAY RELAYS

TS2 / TS6 SERIES

Accessories



P1015-64 (AWG 14/16)
Female Quick Connect

These 0.25 in. (6.35 mm) female terminals are constructed with an insulator barrel to provide strain relief.



P1015-18 Quick Connect to Screw Adapter

Screw adapter terminal designed for use with all modules with 0.25 in. (6.35 mm) male quick connect terminals.



C103PM (AL) DIN Rail

35 mm aluminum DIN rail available in a 36 in. (91.4 cm) length.



P1023-20 DIN Rail Adapter

Allows module to be mounted on a 35 mm DIN type rail with two #10 screws.



VTP(X)(X) Plug-on Adjustment Module

Mounts on modules with in-line adjustment terminals. Rated at 0.25W at 55°C. Available in resistance values from 5KΩ to 5MΩ.

Selection Table for VTP Plug-on Adjustment Accessory

TS6 12VDC			
Time Delay	VTP P/N	Versa-Pot (potentiometer)	
		Fig. A P/N	Fig. B P/N
1 - 0.05-1s	VTP2A	P1004-16	P1004-16-X
2 - 0.5-20s	VTP2E	P1004-16	P1004-16-X
3 - 2-60s	VTP2F	P1004-16	P1004-16-X
4 - 5-120s	VTP2H	P1004-16	P1004-16-X

TS2 & TS6 All Other Voltages			
Time Delay	VTP P/N	Versa-Pot (potentiometer)	
		Fig. A P/N	Fig. B P/N
1 - 0.05-3s	VTP4B	P1004-12	P1004-12-X
2 - 0.5-60s	VTP4F	P1004-12	P1004-12-X
3 - 2-180s	VTP4J	P1004-12	P1004-12-X
4 - 5-600s	VTP5N	P1004-13	P1004-13-X

Function Diagram

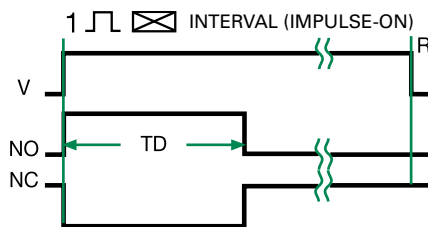

V = Voltage
NO = Normally Open Contact
NC = Normally Closed Contact
TD = Time Delay
R = Reset
— = Undefined Time

Selection Guide

RT Selection Chart				
Desired Time Delay*				RT
Seconds				
1	2	3	4	Megohm
0.05	0.5	2	5	0.0
0.5	10	30	60	0.5
1.0	20	60	120	1.0
▼ 24VDC or AC ONLY† ▼				
1.5	30	90	180	1.5
2.0	40	120	240	2.0
2.5	50	150	300	2.5
3.0	60	180	360	3.0
			420	3.5
			480	4.0
			540	4.5
			600	5.0

* When selecting an external RT add to least 20% for tolerance of unit and the RT.
† 1 Megohm max for 12 VDC Units

Specifications

Time Delay

Type

Analog circuitry

Range

12VDC

0.05 - 120s in 4 adjustable ranges or fixed (1 MΩ max. RT)

Other Voltages

0.05 - 600s in 4 adjustable ranges or fixed ±2% or 20ms, whichever is greater

Repeat Accuracy

Tolerance

≤ ±10%

(Factory Calibration)

Time Delay vs Temp. & Voltage

≤ ±10%

Reset Time

≤ 150ms

Input

Voltage

12 or 24VDC; 24 or 20VAC

Tolerance

±15%

DC Ripple

10%

Power Consumption

DC ≤ 1W; AC ≤ 2VA

Output

Type

Solid state

Form

NO, closed during timing

Maximum Load Current

1A steady state, 10A inrush at 60°C

Voltage Drop

DC ≈ 1.0V @ 1A; AC ≈ 2.5V @ 1A

Protection

Circuitry

Encapsulated

Polarity

TS6 is not reverse polarity protected

Dielectric Breakdown

≥ 2000V RMS terminals to mounting surface

Insulation Resistance

≥ 100 MΩ

Mechanical

Mounting

Surface mount with one #10 (M5 x 0.8) screw

Dimensions

H 50.8 mm (2"); W 50.8 mm (2");

D 30.7 mm (1.21")

Termination

0.25 in. (6.35 mm) male quick connect terminals

Environmental

Operating/Storage

Temperature

-40° to 75°C / -40° to 85°C

Humidity

95% relative, non-condensing

Weight

≈ 2.4 oz (68 g)

TSD2 SERIES

Interval Timer



Description

The TSD2 Series is designed for more demanding commercial and industrial applications where small size and accurate performance are required. The factory calibration for fixed time delays is within 1% of the target time delay. The repeat accuracy, under stable conditions, is 0.1% of the time delay. The TSD Series is rated to operate over an extended temperature range. Time delays of 0.1 seconds to 100 hours are available. The output is rated 1A steady and 10A inrush. The modules are totally solid state and encapsulated to protect the electronic circuitry.

Operation (Interval)

Upon application of input voltage, the time delay begins. The output is energized during the time delay. At the end of the time delay, the output de-energizes and remains de-energized until input voltage is removed.

Reset: Removing input voltage resets the time delay and output.

Wiring Diagram

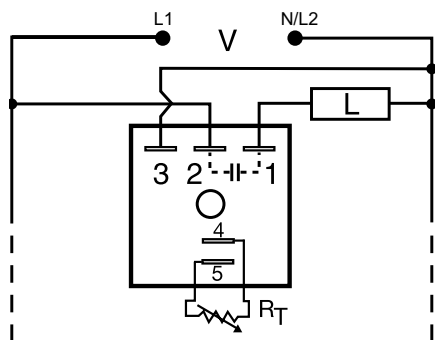

R_T is used when external adjustment is ordered.

Features & Benefits

FEATURES	BENEFITS
Microcontroller based	Repeat Accuracy +/- 0.1%, +/- 1% time delay accuracy
Extended temperature range	Rated to 75°C operating temperature to withstand high heat applications.
Compact, low cost design	Allows flexibility for OEM applications
1A Steady solid-state output, 10A inrush	Provides 100 million operations in typical conditions.
Totally solid state and encapsulated	No moving parts to arc and wear out over time and encapsulated to protect against shock, vibration, and humidity

Accessories



P1004-95, P1004-95-X Versa-Pot
Panel mountable, industrial potentiometer recommended for remote time delay adjustment.



P1023-6 Mounting bracket
The 90° orientation of mounting slots makes installation/removal of modules quick and easy.



P0700-7 Versa-Knob
Designed for 0.25 in. (6.35 mm) shaft of Versa-Pot. Semi-gloss industrial black finish.



P1015-64 (AWG 14/16) Female Quick Connect
These 0.25 in. (6.35 mm) female terminals are constructed with an insulator barrel to provide strain relief.



P1015-18 Quick Connect to Screw Adapter
Screw adapter terminal designed for use with all modules with 0.25 in. (6.35 mm) male quick connect terminals.

For dimensional drawing see: Appendix, page 512, Figure 16.

Ordering Information

MODEL	INPUT VOLTAGE	ADJUSTMENT	TIME DELAY
TSD2411S	120VAC	Fixed	1s
TSD24145S	120VAC	Fixed	45s
TSD241600S	120VAC	Fixed	600s
TSD2434	120VAC	Onboard	1 - 100m

If you don't find the part you need, call us for a custom product 800-843-8848

TSD2 SERIES

Accessories



C103PM (AL) DIN Rail
35 mm aluminum DIN rail available in a 36 in. (91.4 cm) length.



P1023-20 DIN Rail Adapter
Allows module to be mounted on a 35 mm DIN type rail with two #10 screws.

External Resistance vs. Time Delay

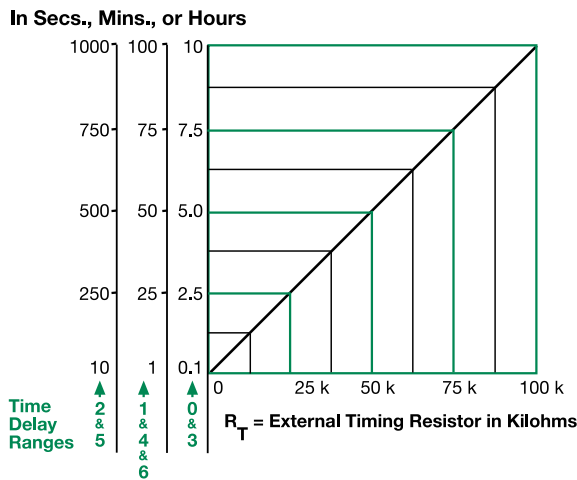

This chart applies to externally adjustable part numbers.
The time delay is adjustable over the time delay range selected by varying the resistance across the R_T terminals; as the resistance increases the time delay increases.
When selecting an external R_T , add the tolerances of the timer and the R_T for the full time range adjustment.
Examples: 1 to 50 S adjustable time delay, select time delay range 1 and a 50 K ohm R_T . For 1 to 100 S use a 100 K ohm R_T .

Function Diagram

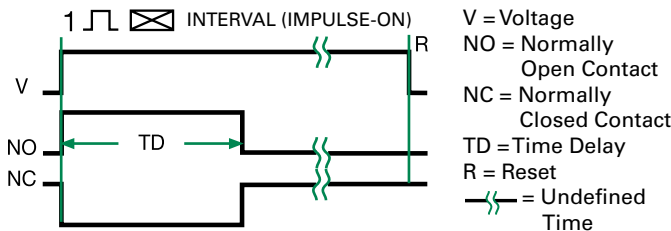

Specifications

Time Delay	
Range	0.1s - 100h in 7 adjustable ranges or fixed
Repeat Accuracy	±0.1% or 20ms, whichever is greater
Tolerance (Factory Calibration)	≤ ±1%
Reset Time	≤ 150ms
Time Delay vs. Temperature & Voltage	≤ ±1%
Input Voltage	24, 120, or 230VAC
Tolerance	±20%
AC Line Frequency	50/60 Hz
Power Consumption	≤ 2VA
Output Type	Solid state
Form	NO, closed during timing
Maximum Load Current	1A steady state, 10A inrush at 60°C
Off State Leakage Current	≅ 5mA @ 230VAC
Voltage Drop	≅ 2.5V @ 1A
Protection Circuitry	Encapsulated
Dielectric Breakdown	≥ 2000V RMS terminals to mounting surface
Insulation Resistance	≥ 100 MΩ
Mechanical Mounting	Surface mount with one #10 (M5 x 0.8) screw
Dimensions	H 50.8 mm (2"); W 50.8 mm (2"); D 30.7 mm (1.21")
Termination	0.25 in. (6.35 mm) male quick connect terminals
Environmental Operating/Storage Temperature	-40° to 75°C / -40° to 85°C
Humidity	95% relative, non-condensing
Weight	≅ 2.4 oz (68 g)

TSD6 SERIES

Interval Timer



Wiring Diagram

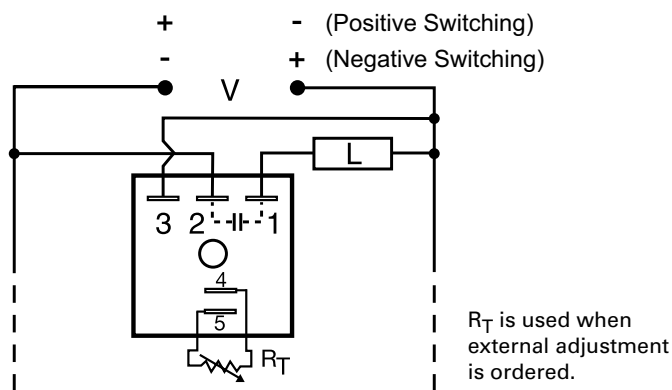

For dimensional drawing see: Appendix, page 512, Figure 16.

Description

The TSD6 Series offers total solid-state, interval timing for 12 or 24VDC applications. This series provides either negative or positive switching. The TSD6 Series is designed for more demanding commercial and industrial applications where small size and accurate performance is required. The factory calibration for fixed time delays is within 1% of the target time delay. The repeat accuracy, under stable conditions, is 0.1% of the time delay. The TSD6 Series is rated to operate over an extended temperature range. Time delays of 0.1 seconds to 100 hours are available. The output is rated 1A steady and 10A inrush. The modules are totally solid state and encapsulated to protect the electronic circuitry.

Operation (Interval)

Upon application of input voltage, the time delay begins. The output energizes during the time delay. At the end of the time delay, the output de-energizes and remains de-energized until input voltage is removed.

Reset: Removing input voltage resets the time delay and the output.

Features & Benefits

FEATURES	BENEFITS
Microcontroller based	Repeat Accuracy +/- 0.1%, +/- 1% time delay accuracy
Extended temperature range	Rated to 75°C operating temperature to withstand high heat applications.
Compact, low cost design	Allows flexibility for OEM applications
1A Steady solid-state output, 10A inrush	Provides 100 million operations in typical conditions.
Totally solid state and encapsulated	No moving parts to arc and wear out over time and encapsulated to protect against shock, vibration, and humidity

Accessories



P1004-95, P1004-95-X Versa-Pot
Panel mountable, industrial potentiometer recommended for remote time delay adjustment.



P1023-6 Mounting bracket
The 90° orientation of mounting slots makes installation/removal of modules quick and easy.



P0700-7 Versa-Knob
Designed for 0.25 in. (6.35 mm) shaft of Versa-Pot. Semi-gloss industrial black finish.



P1015-64 (AWG 14/16) Female Quick Connect
These 0.25 in. (6.35 mm) female terminals are constructed with an insulator barrel to provide strain relief.

Ordering Information

MODEL	INPUT VOLTAGE	ADJUSTMENT	TIME DELAY	SWITCHING MODE
TSD6113SP	12VDC	Fixed	3s	Positive
TSD6115SP	12VDC	Fixed	15s	Positive
TSD6113SN	12VDC	Fixed	3s	Negative
TSD6310.8SN	24VDC	Fixed	0.8s	Negative
TSD631380SP	24VDC	Fixed	380s	Positive
TSD6320P	24VDC	External	0.1 - 10s	Positive

If you don't find the part you need, call us for a custom product 800-843-8848

TSD6 SERIES

Accessories



P1015-18 Quick Connect to Screw Adapter
Screw adapter terminal designed for use with all modules with 0.25 in. (6.35 mm) male quick connect terminals.



C103PM (AL) DIN Rail
35 mm aluminum DIN rail available in a 36 in. (91.4 cm) length.



P1023-20 DIN Rail Adapter
Allows module to be mounted on a 35 mm DIN type rail with two #10 screws.

External Resistance vs. Time Delay

In Secs., Mins., or Hours

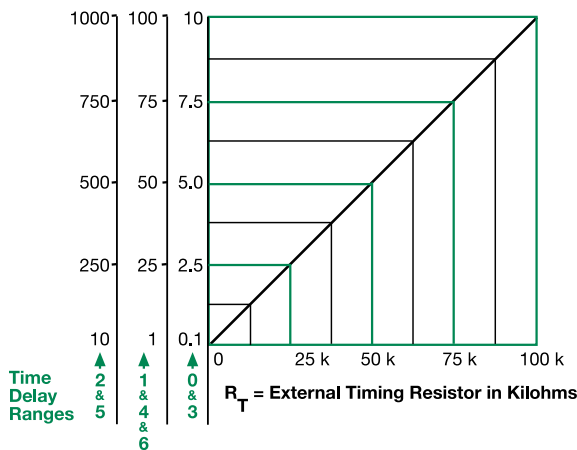

This chart applies to externally adjustable part numbers. The time delay is adjustable over the time delay range selected by varying the resistance across the R_T terminals; as the resistance increases the time delay increases. When selecting an external R_T , add the tolerances of the timer and the R_T for the full time range adjustment. **Examples:** 1 to 50 S adjustable time delay, select time delay range 1 and a 50 K ohm R_T . For 1 to 100 S use a 100 K ohm R_T .

Function Diagram

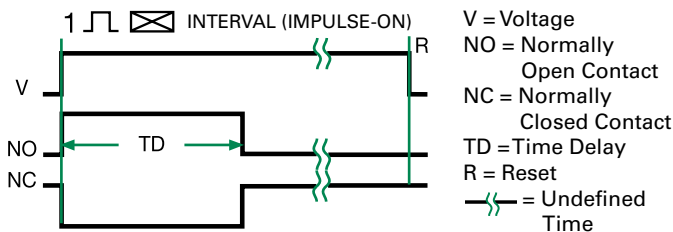

Specifications

Time Delay	
Range	0.1s - 100h in 7 adjustable ranges or fixed
Repeat Accuracy	±0.1% or 20ms, whichever is greater
Tolerance (Factory Calibration)	≤ ±1%
Reset Time	≤ 150ms
Time Delay vs. Temperature & Voltage	≤ ±1%
Input Voltage	12 or 24VDC
Tolerance	±15%
DC Ripple	±10%
Power Consumption	≤ 1W
Output Type	Solid state, positive or negative switching
Form	NO, closed during timing
Maximum Load Current	1A steady state, 10A inrush at 60°C
Off State Leakage Current	≅ 1mA
Voltage Drop	≅ 1.0V @ 1A
Protection Circuitry	Encapsulated
Dielectric Breakdown	≥ 2000V RMS terminals to mounting surface
Insulation Resistance	≥ 100 MΩ
Polarity	Units are reverse polarity protected
Mechanical Mounting	Surface mount with one #10 (M5 x 0.8) screw
Dimensions	H 50.8 mm (2"); W 50.8 mm (2"); D 30.7 mm (1.21")
Termination	0.25 in. (6.35 mm) male quick connect terminals
Environmental Operating/Storage Temperature	-40° to 75°C / -40° to 85°C
Humidity	95% relative, non-condensing
Weight	≅ 2.4 oz (68 g)

TSD7 SERIES

Interval/Delay-on-Break Timer

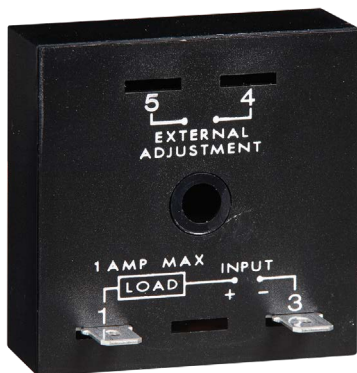

Description

The TSD7 Series utilizes only two terminals connected in series with the load. Interval timing mode period is achieved by using a small portion of the AC sine wave allowing sufficient voltage for circuit operation. It can be used as an interval timer to control or pulse shape the operation of contactors, solenoids, relays, and lamp loads. The TSD7 Series can be wired to delay on the break of a switch for energy saving fan delays.

Operation (Interval)

Upon application of input voltage, the output energizes and the time delay begins. The output remains energized throughout the time delay. At the end of the time delay, the output de-energizes and remains de-energized until power is removed.

Reset: Removing input voltage resets the time delay and the output.

Operation (Delay-on-Break)

Upon closure of SW1, the load is energized and the timer is reset (zero volts across its input terminals). Opening SW1 re-applies input voltage to the timer, the load remains energized and the time delay begins. At the end of the time delay, the output de-energizes. If SW1 is open when power is applied, the load will energize for the time delay then de-energize.

Reset: Reclosing SW1 resets the timer.

Wiring Diagram

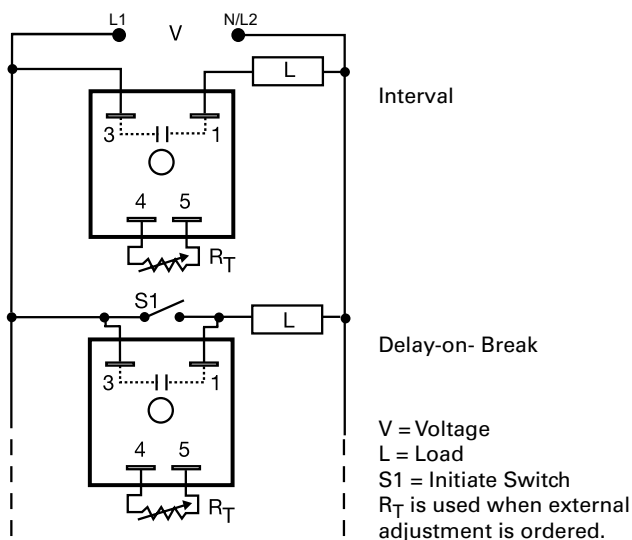

Features & Benefits

FEATURES	BENEFITS
Microcontroller based	Repeat Accuracy +/- 0.5%, +/- 1% time delay accuracy
Extended temperature range	Rated to 75°C operating temperature to withstand high heat applications
Compact, low cost design	Allows flexibility for OEM applications
1A steady solid-state output, 10A inrush	Provides 100 million operations in typical conditions.
Totally solid state and encapsulated	No moving parts to arc and wear out over time and encapsulated to protect against shock, vibration, and humidity
Two terminal series load connections	Provides quick and easy installation for new or existing systems

For dimensional drawing see: Appendix, page 512, Figure 16.

Ordering Information

MODEL	INPUT VOLTAGE	ADJUSTMENT	TIME DELAY	MODEL	INPUT VOLTAGE	ADJUSTMENT	TIME DELAY
TSD7412S	120VAC	Fixed	2s	TSD761120S	230VAC	Fixed	120s
TSD7414M	120VAC	Fixed	4m	TSD761180S	230VAC	Fixed	180s
TSD7421	120VAC	External	1 - 100s	TSD7611S	230VAC	Fixed	1s
TSD7423	120VAC	External	0.1 - 10m	TSD7621	230VAC	External	1 - 100s
TSD7424	120VAC	External	1 - 100m				

If you don't find the part you need, call us for a custom product 800-843-8848

TSD7 SERIES

Accessories



P1004-13, P1004-13-X Versa-Pot
Panel mountable, industrial potentiometer recommended for remote time delay adjustment.



P1023-6 Mounting Bracket
The 90° orientation of mounting slots makes installation/removal of modules quick and easy.



P0700-7 Versa-Knob
Designed for 0.25 in. (6.35 mm) shaft of Versa-Pot. Semi-gloss industrial black finish.



P1015-64 (AWG 14/16) Female Quick Connect
These 0.25 in. (6.35 mm) female terminals are constructed with an insulator barrel to provide strain relief.



P1015-18 Quick Connect to Screw Adapter
Screw adapter terminal designed for use with all modules with 0.25 in. (6.35 mm) male quick connect terminals.



C103PM (AL) DIN Rail
35 mm aluminum DIN rail available in a 36 in. (91.4 cm) length.



P1023-20 DIN Rail Adapter
Allows module to be mounted on a 35 mm DIN type rail with two #10 screws.



VTP(X)(X) Plug-on Adjustment Module
Mounts on modules with in-line adjustment terminals. Rated at 0.25W at 55°C. Available in resistance values from 5KΩ to 5MΩ.

Selection Table for VTP Plug-on Adjustment Accessory

Time Delay	VTP P/N	Time Delay	VTP P/N
1 - 1-100s	VTP5G	4 - 1-100m	VTP5P
2 - 10-1000s	VTP5K	5 - 10-1000m	VTP5R
3 - 0.1-10m	VTP5N		

Selection Guide

RT Selection Chart					
Desired Time Delay*					RT
Seconds		Minutes			
1	2	3	4	5	Megohm
1	10	0.1	1	10	0.0
10	100	1	10	100	0.5
20	200	2	20	200	1.0
30	300	3	30	300	1.5
40	400	4	40	400	2.0
50	500	5	50	500	2.5
60	600	6	60	600	3.0
70	700	7	70	700	3.5
80	800	8	80	800	4.0
90	900	9	90	900	4.5
100	1000	10	100	1000	5.0

* When selecting an external RT add at least 20% for tolerance of unit and the RT.

Specifications

Time Delay

Type Digital integrated circuitry
Range 1s - 1000m in 5 adjustable ranges or fixed
Repeat Accuracy ±0.5% or 20ms, whichever is greater

Tolerance (Factory Calibration) ≤ ±10%

Recycle Time ≤ 400ms

Time Delay vs Temp. & Voltage ≤ ±2%

Input

Voltage 24, 120, or 230VAC

Tolerance ±20%

AC Line Frequency 50/60 Hz

Output

Type Solid state

Form NO, closed during timing

Maximum Load Current 1A steady state, 10A inrush at 45°C

Minimum Load Current 40mA

Effective Voltage Drop (VLine-VLoad)

Input	Effective Drop
24VAC	3V
120VAC	4V
230VAC	6V

Protection

Circuitry Encapsulated

Dielectric Breakdown ≥ 2000V RMS terminals to mounting surface

Insulation Resistance ≥ 100 MΩ

Mechanical

Mounting

Surface mount with one #10 (M5 x 0.8) screw

Dimensions

H 50.8 mm (2"); **W** 50.8 mm (2");
D 30.7 mm (1.21")

Termination

0.25 in. (6.35 mm) male quick connect terminals

Environmental

Operating/Storage Temperature

-40° to 75°C / -40° to 85°C

Humidity

95% relative, non-condensing

Weight

≈ 2.4 oz (68 g)

Function Diagrams

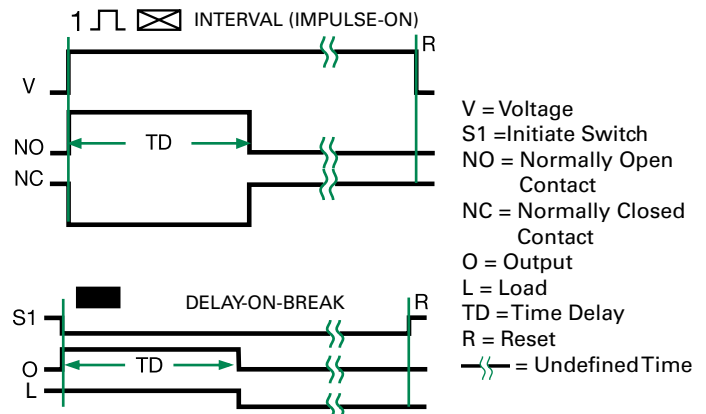

KRD9 SERIES



Wiring Diagram

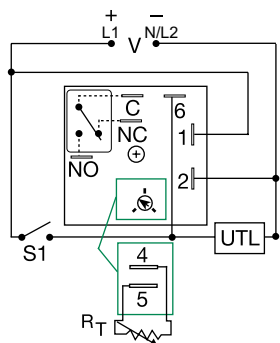

V = Voltage
S1 = Initiate Switch C = Common, Transfer Contact
UTL = Untimed Load (optional)

A knob is supplied for adjustable units, or R_T terminals 4 & 5 for external adjust. See external adjustment vs time delay chart. The untimed load is optional. Relay contacts are isolated.

For dimensional drawing see: Appendix, page 512, Figure 16.

Description

The KRD9 Series microcontroller timing circuit provides excellent repeat accuracy and stability. Cost effective approach for OEM applications that require small size, isolation, reliability, and long life.

Operation (Retriggerable Single Shot)

Function Type A (Output Initially De-energized): Input voltage must be applied prior to and during timing. When the initiate switch is closed, (momentary or maintained) the output energizes and the time delay starts. On completion of the delay, the output de-energizes. The unit will time out if S1 remains in the open or closed position for the full time delay. Reclosing the initiate switch resets the time delay and restarts timing; the output remains energized. The output will not energize if the initiate switch is closed when input voltage is applied.

Function Type B (Output Initially Energized): Upon application of input voltage, the output energizes and the time delay starts. At the end of the time delay, the load de-energizes. The unit will time out if S1 remains in the open or closed position for the full time delay. Closing (re-closing) the initiate switch resets the time delay and restarts timing; the output remains energized.

Reset: The time delay and the output are reset when input voltage is removed.

Features & Benefits

FEATURES	BENEFITS
Microcontroller based	Repeat Accuracy +/- 0.5%, Factory calibration +/- 5%
Compact, low cost design	Allows flexibility for OEM applications and reduces labor and component costs
Isolated, 10A, SPDT output contacts	Allows control of loads for AC or DC voltages
Encapsulated circuitry	Protects against shock, vibration, and humidity

Accessories



P1004-95, P1004-95-X Versa-Pot
Panel mountable, industrial potentiometer recommended for remote time delay adjustment.



P1023-6 Mounting bracket
The 90° orientation of mounting slots makes installation/removal of modules quick and easy.



P0700-7 Versa-Knob
Designed for 0.25 in (6.35 mm) shaft of Versa-Pot. Semi-gloss industrial black finish.



P1015-13 (AWG 10/12), P1015-64 (AWG 14/16) Female Quick Connect
These 0.25 in. (6.35 mm) female terminals are constructed with an insulator barrel to provide strain relief.

Ordering Information

MODEL	INPUT VOLTAGE	ADJUSTMENT	TIME DELAY	FUNCTION TYPE
KRD9120B	12VDC	Onboard	0.1 - 10s	Energized
KRD92115MA	24VAC/DC	Fixed	15m	De-energized
KRD92115MB	24VAC/DC	Fixed	15m	Energized
KRD9220B	24VAC/DC	Onboard	0.1 - 10s	Energized
KRD93115MA	24VDC	Fixed	15m	De-energized
KRD9423B	120VAC	Onboard	0.1 - 10m	Energized

If you don't find the part you need, call us for a custom product 800-843-8848

KRD9 SERIES

Accessories



P1015-18 Quick Connect to Screw Adapter
Screw adapter terminal designed for use with all modules with 0.25 in. (6.35 mm) male quick connect terminals.



C103PM (AL) DIN Rail
35 mm aluminum DIN rail available in a 36 in. (91.4 cm) length.



P1023-20 DIN Rail Adapter
Allows module to be mounted on a 35 mm DIN type rail with two #10 screws.

External Resistance vs. Time Delay

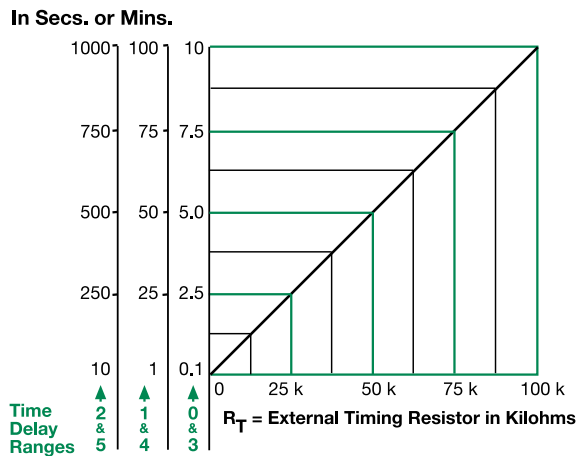

This chart applies to externally adjustable part numbers.
The time delay is adjustable over the time delay range selected by varying the resistance across the R_T terminals; as the resistance increases the time delay increases.

When selecting an external R_T , add the tolerances of the timer and the R_T for the full time range adjustment.

Examples: 1 to 50 S adjustable time delay, select time delay range 1 and a 50 K ohm R_T . For 1 to 100 S use a 100 K ohm R_T .

Output Current/Ambient Temperature

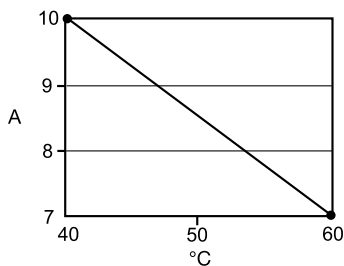

Specifications

Time Delay	Microcontroller based with watchdog circuitry
Type	0.1s - 1000ms in 6 adjustable ranges or fixed
Range	±0.5% or 20ms, whichever is greater
Repeat Accuracy	
Tolerance	
(Factory Calibration)	≤ ±5%
Reset Time	≤ 150ms
Initiate Time	≤ 40ms; ≤ 750 operations per minute
Time Delay vs Temp. & Voltage	≤ ±5%
Input	
Voltage	12, 24 or 110VDC; 24, 120 or 230VAC
Tolerance	
12VDC & 24VDC/AC	-15% - +20%
110VDC, 120 or 230VAC	-20% - +10%
AC Line Frequency/DC Ripple	50/60 Hz / ≤ 10%
Power Consumption	AC ≤ 2VA; DC ≤ 2W
Output	
Type	Isolated relay contacts
Form	SPDT
Rating (at 40°C)	10A resistive @ 125VAC; 5A resistive @ 230VAC & 28VDC; 1/4 hp @ 125VAC 250VAC
Max. Switching Voltage	250VAC
Life (Operations)	Mechanical - 1 x 10 ⁷ ; Electrical - 1 x 10 ⁵
Protection	
Circuitry	Encapsulated
Isolation Voltage	≥ 1500V RMS input to output
Insulation Resistance	≥ 100 MΩ
Polarity	DC units are reversed polarity protected
Mechanical	
Mounting	Surface mount with one #10 (M5 x 0.8) screw
Dimensions	H 50.8 mm (2.0"); W 50.8 mm (2.0"); D 30.7 mm (1.21")
Termination	0.25 in. (6.35 mm) male quick connect terminals
Environmental	
Operating/Storage	
Temperature	-40° to 60°C / -40° to 85°C
Humidity	95% relative, non-condensing
Weight	≈ 2.6 oz (74 g)

Function Diagram

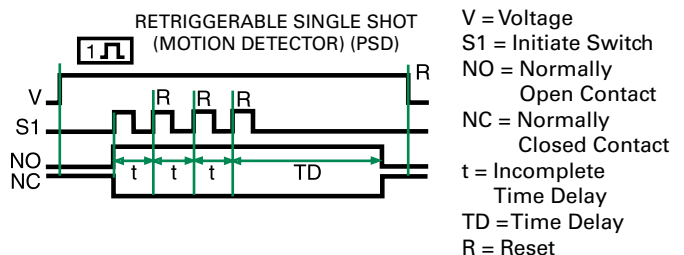

TSD94110SB

Retriggerable Single-Shot Timer

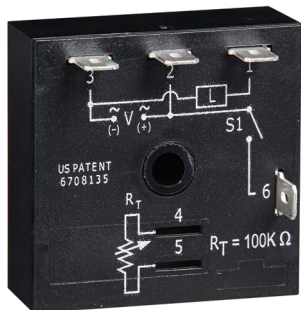

Wiring Diagram

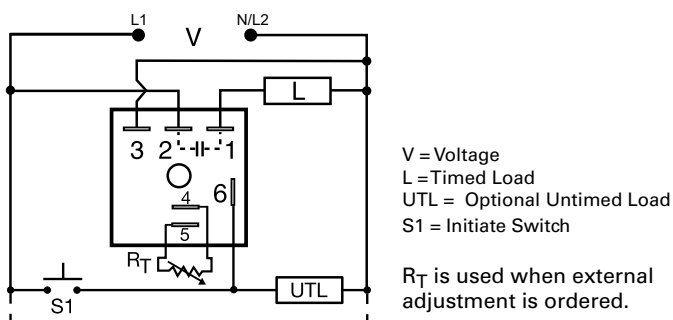

For dimensional drawing see: Appendix, page 512, Figure 16.

Description

The TSD94110SB retriggerable single-shot timer is designed for a variety of applications. Its digital circuit provides long or short delays with accuracy and stability over a wide voltage and temperature range. It is the ideal timer for pulse-train monitoring of programmable controllers, or any system requiring motion detection.

Operation A Type

Power must be applied to input at all times prior to and during timing. Upon closure of initiate switch (momentary or maintained) the load is energized and the time delay is started. On completion of the delay period the load is de-energized. Should the initiate switch be reclosed during timing, the delay will be reset to zero and restarted.

Operation B Type

Upon application of input power, the load is energized and a time delay is started. At the end of the time delay, the load is de-energized. Should the initiate switch be closed or reclosed during timing, the delay is reset to zero and restarted.

Features & Benefits

- Excellent Pulse Train Monitor
- Totally Solid State and Encapsulated
- Microcontroller Circuitry
- Fast Reset to Zero During Timing
- Excellent Accuracy and Reliability
- DC Units are Reverse Polarity Protected

Specifications

Time Delay

Type	Microcontroller circuitry
Range	Factory fixed 10s
Repeat Accuracy	±0.5%
Tolerance	
(Factory Calibration)	±1%
Recycle Time	300ms max.
Time Delay vs. Temp. & Voltage	±2%
Initiate Timing	16ms max. AC
Input	
Operating Voltage	120 volts AC
Tolerance	±15%
Output	
Type	Solid State
Form	Normally open
Rating	1 ampere steady state, 10 amperes inrush at 55°C
Voltage Drop	AC 2.5 volts typical at 1 ampere
Protection	
Transient	Protected
Dielectric	1500 volts RMS
Insulation Resistance	100 megohms minimum 4.4

Mechanical

Mounting	Surface mount with one #8 or #10 screw
Termination	0.25 in. (6.35 mm) male quick connect terminals
Package	Molded housing with encapsulated circuitry
Dimensions	H 50.80 mm (2.00"); W 50.80 mm (2.00"); D 30.70 mm (1.21")

Environmental

Operating/Storage Temperature	-40°C to 60°C / -40°C to 85°C
Humidity	95% relative, non-condensing
Weight	Approx. 2.4 oz (68 g)

Function Diagram

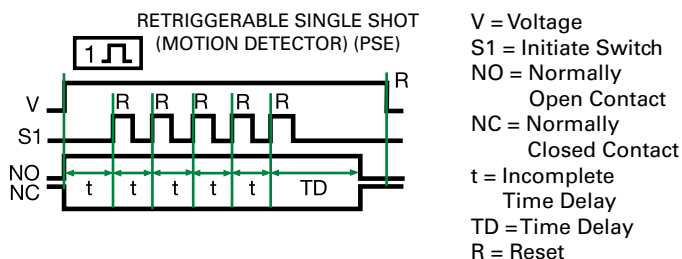

12 TIME DELAY RELAYS

ERD3425A



Description

Econo-Timers are a combination of digital electronics and a reliable electromechanical relay. DPDT relay output for relay logic circuits, and isolation of input to output voltages. Cost effective for OEM applications, such as duty cycling, drying, washing, signaling, and flashing.

Operation (Recycling - ONTime First)

Upon application of input voltage, the output relay energizes and the T1 ON time begins. At the end of the ON time, the output de-energizes and the T2 OFF time begins. At the end of the OFF time, the output relay energizes and the cycle repeats as long as input voltage is applied.

Reset: Removing input voltage resets the output and time delays, and returns the sequence to the first delay.

Features & Benefits

FEATURES	BENEFITS
Digital integrated circuitry	Repeat Accuracy +/- 0.5%, Factory calibration +/- 10%
Isolated, 10A, DPDT output contacts	Allows control of loads for AC or DC voltages
Encapsulated	Protects against shock, vibration, and humidity

Wiring Diagram

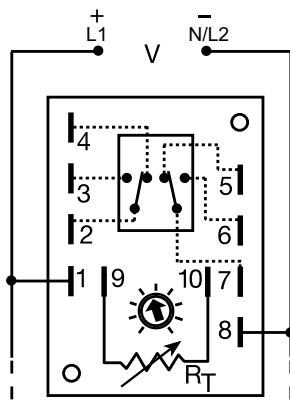

A knob, or terminals 9 & 10 are only included on adjustable units.

Relay contacts are isolated.

R_T is used when external adjustment is ordered.

For dimensional drawing see: Appendix, page 512, Figure 25.

Accessories



P1004-16, P1004-16-X Versa-Pot

Panel mountable, industrial potentiometer recommended for remote time delay adjustment.



P0700-7 Versa-Knob

Designed for 0.25 in. (6.35 mm) shaft of Versa-Pot. Semi-gloss industrial black finish.



P1015-64 (AWG 14/16) Female Quick Connect

These 0.25 in. (6.35 mm) female terminals are constructed with an insulator barrel to provide strain relief.



P1015-18 Quick Connect to Screw Adapter

Screw adapter terminal designed for use with all modules with 0.25 in. (6.35 mm) male quick connect terminals.

ERD3425A

Selection Guides

RT Selection Chart						
Desired Time Delay*						RT Megohm
Seconds						
1	2	3	4	5	6	
0.1	0.1	0.1	0.2	0.3	0.6	0.0
0.19	0.6	1	1.7	3	6	0.1
0.28	1.1	2	3.2	6	12	0.2
0.37	1.6	3	4.7	9	18	0.3
0.46	2.1	4	6.2	12	24	0.4
0.55	2.6	5	7.7	15	30	0.5
0.64	3.0	6	9.2	18	36	0.6
0.73	3.5	7	10.7	21	42	0.7
0.82	4.0	8	12.2	24	48	0.8
0.91	4.5	9	13.7	27	54	0.9
1.0	5.0	10	15	30	60	1.0

* When selecting an external RT add at least 20% for tolerance of unit and the RT.

RT Selection Chart					
Desired Time Delay*					RT Megohm
Minutes					
7	8	9	10	11	
0.1	0.1	0.2	1	10	0.0
0.6	1	1.7	10	50	0.1
1.1	2	3.2	20	100	0.2
1.6	3	4.7	30	150	0.3
2.1	4	6.2	40	200	0.4
2.6	5	7.7	50	250	0.5
3.0	6	9.2	60	300	0.6
3.5	7	10.7	70	350	0.7
4.0	8	12.2	80	400	0.8
4.5	9	13.7	90	450	0.9
5.0	10	15	100	500	1.0

* When selecting an external RT add at least 20% for tolerance of unit and the RT.

Function Diagram

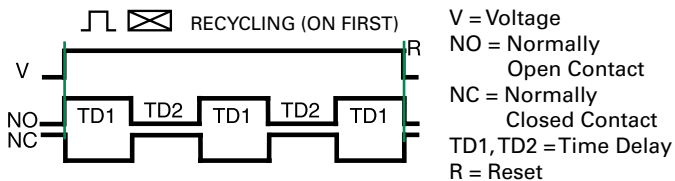

Specifications

Time Delay

Type

Digital integrated circuitry

Range

0.1s - 500m in 11 adjustable ranges

0.1s - 1000m fixed

Adjustment

Knob, external adjust, or fixed

Repeat Accuracy

±0.5%

Tolerance

(Factory Calibration)

≤ ±10%

Reset Time

≤ 150ms

Time Delay vs Temp.

≤ ±2%

& Voltage

≤ ±2%

Input

Voltage

12, 24, or 120VDC; 24, 120, or 230VAC

Tolerance

12VDC & 24VDC/AC

-15% - 20%

120VAC/DC & 230VAC

-20% - 10%

AC Line Frequency

50/60 Hz

Output

Type

Isolated relay contacts

Form

DPDT

Rating

10A resistive @ 120/240VAC & 28VDC;

1/3 hp @ 120/240VAC

Life

Mechanical - 1 x 10⁷; Electrical - 1 x 10⁶

Protection

Isolation Voltage

≥ 1500V RMS input to output

Insulation Resistance

≥ 100 MΩ

Polarity

DC units are reverse polarity protected

Mechanical

Mounting

Surface mount with two #6 (M3.5 x 0.6) screws

Dimensions

H 88.9 mm (3.5"); **W** 63.5 mm (2.5");

D 43.2 mm (1.7")

Termination

0.25 in. (6.35 mm) male quick connect terminals

Environmental

Operating/Storage

Temperature

-40° to 65°C / -40° to 85°C

Weight

≈ 5.7 oz (162 g)

ESDR SERIES



Wiring Diagram

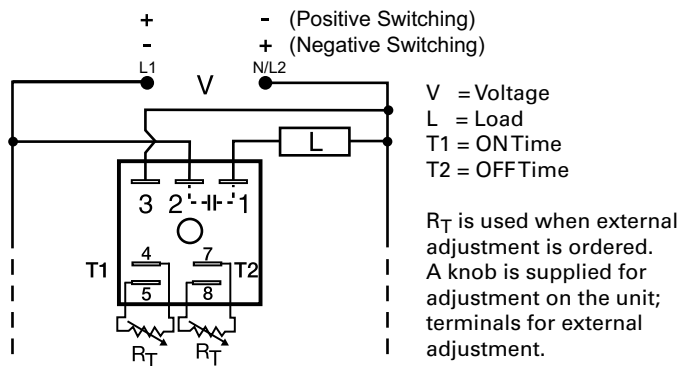

For dimensional drawing see: Appendix, page 512, Figure 16.

Accessories



P1004-95, P1004-95-X Versa-Pot
Panel mountable, industrial potentiometer recommended for remote time delay adjustment.



P1023-6 Mounting bracket
The 90° orientation of mounting slots makes installation/removal of modules quick and easy.



P0700-7 Versa-Knob
Designed for 0.25 in. (6.35 mm) shaft of Versa-Pot. Semi-gloss industrial black finish.



P1015-64 (AWG 14/16) Female Quick Connect
These 0.25 in. (6.35 mm) female terminals are constructed with an insulator barrel to provide strain relief.



P1015-18 Quick Connect to Screw Adapter
Screw adapter terminal designed for use with all modules with 0.25 in. (6.35 mm) male quick connect terminals.



C103PM (AL) DIN Rail
35 mm aluminum DIN rail available in a 36 in. (91.4 cm) length.



P1023-20 DIN Rail Adapter
Allows module to be mounted on a 35 mm DIN type rail with two #10 screws.

Description

The ESDR Series offers independent time adjustment of both delay periods. Adjustment options include fixed, onboard or external adjust. The ESDR is recommended for air drying, automatic oiling, life testing, chemical metering and automatic duty cycling. This series is designed for general purpose commercial and industrial applications where a small, cost effective, reliable, solid-state timer is required. The factory calibration for fixed time delays is $\pm 5\%$. The repeat accuracy, under stable conditions, is 0.1% of the selected time delay. This series is designed for input voltages of 12VDC to 230VAC in five ranges. Time delays of 0.1 seconds to 1000 minutes are available in six ranges. The output is rated 1A steady and 10A inrush. The modules are totally solid state and encapsulated to protect the electronic circuitry.

Operation (Recycling - ON Time First)

Upon application of input voltage, the output energizes and the T1, ON time begins. At the end of the ON time, the output de-energizes and the T2, OFF time begins. At the end of the OFF time, the output energizes and the cycle repeats as long as input voltage is applied.

Reset: Removing input voltage resets the output and time delays, and returns the sequence to the first delay.

Operation (Recycling - OFF Time First)

Upon application of input voltage, the T2 OFF time begins. At the end of the OFF time, the output energizes and the T1 ON time begins. At the end of the ON time, the output de-energizes and the cycle repeats as long as input voltage is applied.

Reset: Removing input voltage resets the output and time delays, and returns the sequence to the first delay.

Features & Benefits

FEATURES	BENEFITS
Microcontroller based	Repeat Accuracy + / - 0.1%, Factory calibration + / - 5%
1A steady, 10A inrush solid-state output	Provides 100 million operations in typical conditions.
Totally solid state and encapsulated	No moving parts to arc and wear out over time and encapsulated to protect against shock, vibration, and humidity
ON/OFF recycling with independent adjustment of both time periods	Separate on and off timing settings are knob adjustable for added flexibility
Compact, low cost design measuring 2 in. (50.8mm) square	Allows flexibility for OEM applications

Ordering Information

See next page.

ESDR SERIES

Ordering Information

MODEL	INPUT VOLTAGE	ADJUSTMENT	T1 ON TIME	FIRST DELAY	T2 OFF TIME	SWITCHING MODE
ESDR120A0P	12VDC	Onboard	0.1 - 10s	On time	0.1 - 10s	Positive
ESDR120B3P	12VDC	Onboard	0.1 - 10s	Off time	0.1 - 10m	Positive
ESDR123B4P	12VDC	Onboard	0.1 - 10m	Off time	1 - 100m	Positive
ESDR125A5P	12VDC	Onboard	10 - 1000m	On time	10 - 1000m	Positive
ESDR221A2	24VAC	Onboard	1 - 100s	On time	10 - 1000s	n/a
ESDR320A0P	24VDC	Onboard	0.1 - 10s	On time	0.1 - 10s	Positive
ESDR320A3P	24VDC	Onboard	0.1 - 10s	On time	0.1 - 10m	Positive
ESDR420A0	120VAC	Onboard	0.1 - 10s	On time	0.1 - 10s	n/a
ESDR420A1	120VAC	Onboard	0.1 - 10s	On time	1 - 100s	n/a
ESDR420A4	120VAC	Onboard	0.1 - 10s	On time	1 - 100m	n/a
ESDR420B1	120VAC	Onboard	0.1 - 10s	Off time	1 - 100s	n/a
ESDR420B4	120VAC	Onboard	0.1 - 10s	Off time	1 - 100m	n/a
ESDR421A1	120VAC	Onboard	1 - 100s	On time	1 - 100s	n/a
ESDR421A4	120VAC	Onboard	1 - 100s	On time	1 - 100m	n/a
ESDR423A3	120VAC	Onboard	0.1 - 10m	On time	0.1 - 10m	n/a
ESDR423A4	120VAC	Onboard	0.1 - 10m	On time	1 - 100m	n/a
ESDR424A1	120VAC	Onboard	1 - 100m	On time	1 - 100s	n/a
ESDR450A1	120VAC	External	0.1 - 10s	On time	1 - 100s	n/a

If you don't find the part you need, call us for a custom product 800-843-8848

External Resistance vs. Time Delay

In Secs. or Mins.

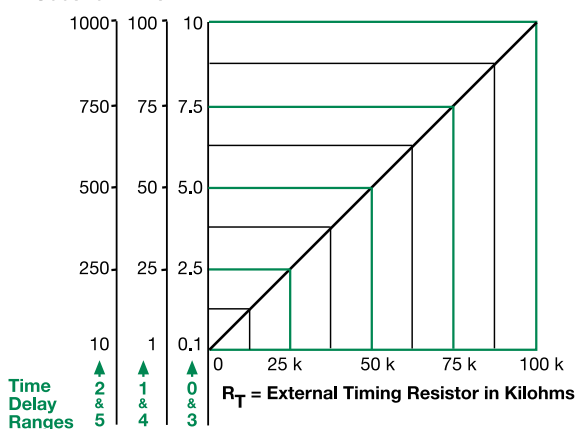

This chart applies to externally adjustable part numbers.
The time delay is adjustable over the time delay range selected by varying the resistance across the R_T terminals; as the resistance increases the time delay increases.

When selecting an external R_T , add the tolerances of the timer and the R_T for the full time range adjustment.

Examples: 1 to 50 S adjustable time delay, select time delay range 1 and a 50 K ohm R_T . For 1 to 100 S use a 100 K ohm R_T .

Function Diagrams

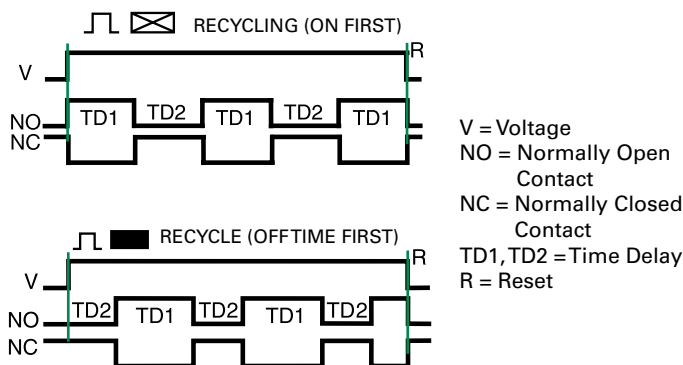

ESDR SERIES

Specifications

Time Delay

Range 0.1s - 1000ms in 6 adjustable ranges or fixed
Repeat Accuracy $\pm 0.1\%$ or 20ms, whichever is greater

Tolerance
(Factory Calibration) $\leq \pm 5\%$

Time Delay vs Temp.
& Voltage $\leq \pm 2\%$

Reset Time $\leq 150\text{ms}$

Input

Voltage 12 or 24VDC; 24, 120, or 230VAC

Tolerance $\pm 20\%$

Power Consumption AC $\leq 2\text{VA}$; DC $\leq 1\text{W}$

AC Line Frequency/DC Ripple 50/60 Hz / $\leq 10\%$

Output

Type Solid state

Maximum Load Current 1A steady state, 10A inrush at 60°C

OFF State Leakage Current AC $\cong 5\text{mA}$ @ 230VAC; DC $\cong 1\text{mA}$

Voltage Drop AC $\cong 2.5\text{V}$ @ 1A; DC $\cong 1\text{V}$ @ 1A

Protection

Circuitry

Dielectric Breakdown

Insulation Resistance

Polarity

Mechanical

Mounting

Dimensions

Termination

Operating/Storage

Temperature

Humidity

Weight

Encapsulated
 $\geq 2000\text{V RMS}$ terminals to mounting surface
 $\geq 100\text{ M}\Omega$
DC units are reverse polarity protected

Surface mount with one #10 (M5 x 0.8) screw
H 50.8 mm (2"); **W** 50.8 mm (2");
D 30.7 mm (1.21")
0.25 in. (6.35 mm) male quick connect terminals

-40° to 75°C / -40° to 85°C
95% relative, non-condensing
 $\cong 2.4\text{ oz}$ (68 g)

HRDR SERIES

Recycling Timer



Description

The HRDR Series combines an electromechanical relay and microcontroller timing circuitry. It offers 12 to 230V operation in five ranges and factory fixed, onboard or externally adjustable time delays with a repeat accuracy of $\pm 0.5\%$. The high switching capacity of the output contacts allow for direct control of heavy loads like compressors, pumps, motors, heaters and lighting. A bypass/reset switch option allows operator to interrupt normal recycling sequence and energize output relay. An excellent choice for OEM applications.

Operation (Recycling with Reset Switch)

Upon application of input voltage, the ON time T1 begins and output relay energizes. At the end of the ON time, the output relay de-energizes and the OFF time T2 begins. At the end of the OFF time, the output relay energizes and the cycle repeats as long as input voltage is applied. Some recycling timers have the OFF time as the first delay.

Reset: Removing input voltage resets output and time delays, and returns sequence to the first delay.

Bypass/Reset Switch: Closing the normally open bypass/reset switch energizes the output relay and resets the time delays. Opening the switch restarts recycling operation with the first delay.

Wiring Diagram

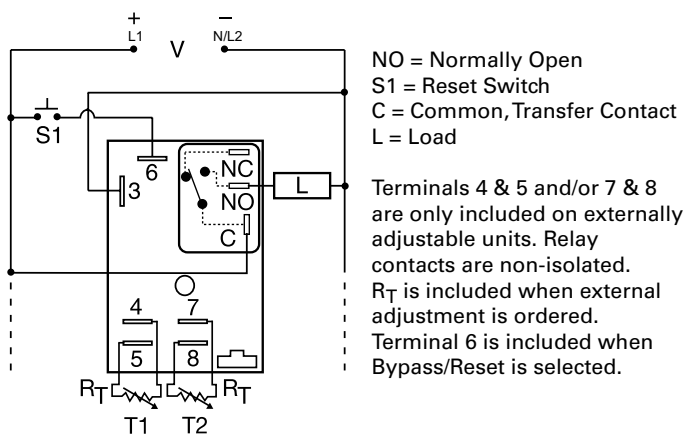

Features & Benefits

FEATURES	BENEFITS
Microcontroller based	Repeat Accuracy + / - 0.5%
Compact, low cost design	Allows flexibility for OEM applications
Isolated, 30A, SPDT, NO output contacts	Allows direct operation of heavy loads: compressors, pumps, blower motors, heaters.
Encapsulated	Protects against shock, vibration, and humidity
Independent adjustment of On and Off delays	Provides greater flexibility of timing options
Bypass/Reset switch option	Allows operator to interrupt the timing sequence and energize the output relay

For dimensional drawing see: Appendix, page 512, Figure 17.

Ordering Information

MODEL	INPUT VOLTAGE	EXTERNAL ADJUSTMENT	T1 ON TIME	OPERATING SEQUENCE	T2 OFF TIME	BYPASS / RESET OPTION
HRDR121A4R	12VDC	Both time onboard adj	1 - 100s	On time first	1 - 100m	Yes
HRDR321A4R	24VDC	Both time onboard adj	1 - 100s	On time first	1 - 100m	Yes
HRDR322B2R	24VDC	Both time onboard adj	10 - 1000S	Off time first	10 - 1000S	Yes
HRDR330A0R	24VDC	Both time external adj	0.1 - 10s	On time first	0.1 - 10s	Yes
HRDR331A1	24VDC	Both time external adj	1 - 100s	On time first	1 - 100s	No
HRDR411SB30MR	120VAC	Both times fixed	1s	Off time first	30m	Yes
HRDR431A1R	120VAC	Both times external adj	0.1 - 100s	On time first	0.1 - 100s	Yes

If you don't find the part you need, call us for a custom product 800-843-8848

HRDR SERIES

Accessories



P1004-95, P1004-95-X Versa-Pot
Panel mountable, industrial potentiometer recommended for remote time delay adjustment.



P1023-6 Mounting bracket
The 90° orientation of mounting slots makes installation/removal of modules quick and easy.



P0700-7 Versa-Knob
Designed for 0.25 in. (6.35 mm) shaft of Versa-Pot. Semi-gloss industrial black finish.



P1015-13 (AWG 10/12), P1015-64 (AWG 14/16) Female Quick Connect
These 0.25 in. (6.35 mm) female terminals are constructed with an insulator barrel to provide strain relief.



P1015-18 Quick Connect to Screw Adapter
Screw adapter terminal designed for use with all modules with 0.25 in. (6.35 mm) male quick connect terminals.



C103PM (AL) DIN Rail
35 mm aluminum DIN rail available in a 36 in. (91.4 cm) length.



P1023-20 DIN Rail Adapter
Allows module to be mounted on a 35 mm DIN type rail with two #10 screws.

External Resistance vs. Time Delay

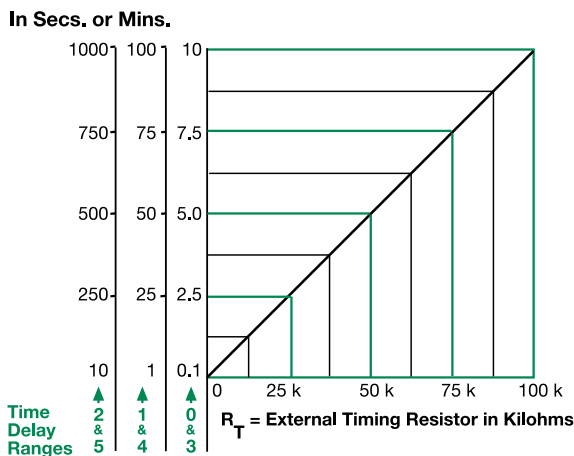

This chart applies to externally adjustable part numbers. The time delay is adjustable over the time delay range selected by varying the resistance across the R_T terminals; as the resistance increases the time delay increases. When selecting an external R_T , add the tolerances of the timer and the R_T for the full time range adjustment.
Examples: 1 to 50 S adjustable time delay, select time delay range 1 and a 50 K ohm R_T . For 1 to 100 S use a 100 K ohm R_T .

Specifications

Time Delay	100ms - 1000ms in 6 adjustable ranges or fixed		
Range	±0.5% or 20ms, whichever is greater		
Repeat Accuracy			
Tolerance (Factory Calibration)	±5%		
Reset Time	≤ 150ms		
Time Delay vs Temp. & Voltage	≤ ±2%		
Input Voltage	12 or 24VDC; 24, 120, or 230VAC		
Tolerance 12VDC & 24VDC	-15% - 20%		
24 to 230VAC	-20% - 10%		
AC Line Frequency	50/60 Hz		
Power Consumption	AC ≤ 4VA; DC ≤ 2W		
Output Type	Electromechanical relay		
Form	SPDT, non-isolated		
Ratings	SPDT-NO	SPDT-NC	
General Purpose	125/240VAC	30A	15A
Resistive	125/240VAC	30A	15A
	28VDC	20A	10A
Motor Load	125VAC	1 hp*	1/4 hp**
	240VAC	2 hp**	1 hp**
Life	Mechanical - 1 x 10 ⁶ ; Electrical - 1 x 10 ⁵ , *3 x 10 ⁴ , **6,000		
Protection	IEEE C62.41-1991 Level A		
Surge	Encapsulated		
Circuitry	≥ 2000V RMS terminals to mounting surface		
Dielectric Breakdown	≥ 100 MΩ		
Insulation Resistance	DC units are reverse polarity protected		
Polarity			
Mechanical			
Mounting	Surface mount with one #10 (M5 x 0.8) screw		
Dimensions	H 76.7 mm (3"); W 51.3 mm (2"); D 38.1 mm (1.5")		
Termination	0.25 in. (6.35 mm) male quick connect terminals		
Environmental			
Operating/Storage Temperature	-40° to 60°C / -40° to 85°C		
Humidity	95% relative non-condensing		
Weight	≈ 3.9 oz (111 g)		

Function Diagram

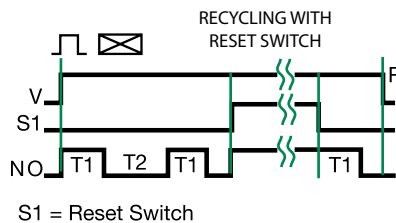

KRD3 SERIES



Wiring Diagram

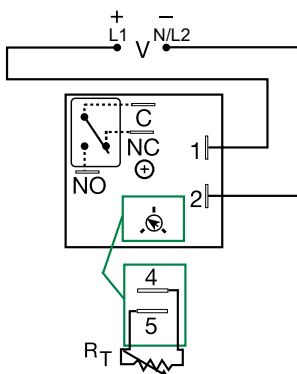

V = Voltage
C = Common, Transfer Contact
NO = Normally Open
NC = Normally Closed

A knob is supplied for adjustable units, or R_T terminals 4 & 5 for external adjust. See external adjustment vs time delay chart.

Relay contacts are isolated.

For dimensional drawing see: Appendix, page 512, Figure 16.

Description

The KRD3 Series measures only 2 in. (50.8 mm) square. Its solid-state timing circuit provides excellent repeat accuracy and stability. Encapsulation protects against shock, vibration, and humidity. The KRD3 Series is a cost effective approach for OEM applications that require small size, isolation, reliability, and long life.

Operation (Recycling Flasher - ON Time First)

Upon application of input voltage, the output energizes and the T1 ON time begins. At the end of the ON time, the output de-energizes and the T2 OFF time begins. At the end of the OFF time, the output energizes and the cycle repeats as long as input voltage is applied.

Reset: Removing input voltage resets the output and time delays, and returns the sequence to T1 ON time.

Features & Benefits

FEATURES	BENEFITS
Compact, low cost design measuring 2 in. (50.8mm) square	Provides greater flexibility for OEM applications and reduces component and labor costs
Microcontroller based	Repeat Accuracy + / - 0.5%, Factory calibration + / - 5%
Isolated, 10A, SPDT output contacts	Allows control of loads for AC or DC voltages
Encapsulated	Protects against shock, vibration, and humidity

Accessories



P1004-95, P1004-95-X Versa-Pot
Panel mountable, industrial potentiometer recommended for remote time delay adjustment.



P1023-6 Mounting bracket
The 90° orientation of mounting slots makes installation/removal of modules quick and easy.



P0700-7 Versa-Knob
Designed for 0.25 in. (6.35 mm) shaft of Versa-Pot. Semi-gloss industrial black finish.



P1015-13 (AWG 10/12), P1015-64 (AWG 14/16) Female Quick Connect
These 0.25 in. (6.35 mm) female terminals are constructed with an insulator barrel to provide strain relief.



P1015-18 Quick Connect to Screw Adapter
Screw adapter terminal designed for use with all modules with 0.25 in. (6.35 mm) male quick connect terminals.



C103PM (AL) DIN Rail
35 mm aluminum DIN rail available in a 36 in. (91.4 cm) length.



P1023-20 DIN Rail Adapter
Allows module to be mounted on a 35 mm DIN type rail with two #10 screws.

Ordering Information

MODEL	INPUT VOLTAGE	ADJUSTMENT	TIME DELAY	OPERATING SEQUENCE
KRD3420A	120VAC	Onboard knob	0.1 - 10s	On time first
KRD3421A	120VAC	Onboard knob	1 - 100s	On time first
KRD3434A	120VAC	External	1 - 100m	On time first

If you don't find the part you need, call us for a custom product 800-843-8848

KRD3 SERIES

External Resistance vs. Time Delay

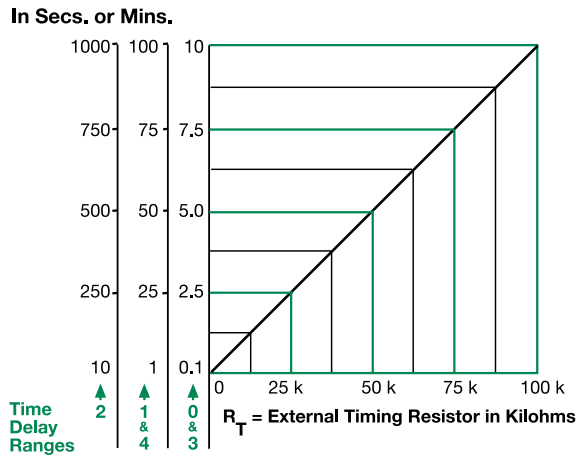

This chart applies to externally adjustable part numbers. The time delay is adjustable over the time delay range selected by varying the resistance across the RT terminals; as the resistance increases the time delay increases. When selecting an external RT, add the tolerances of the timer and the RT for the full time range adjustment.
Examples: 1 to 50 S adjustable time delay, select time delay range 1 and a 50 K ohm RT. For 1 to 100 S use a 100 K ohm RT.

Output Current/Ambient Temperature

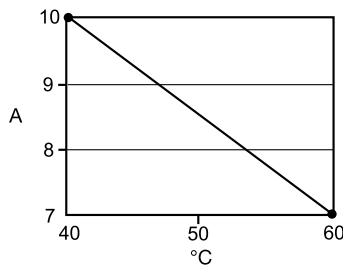

Function Diagram

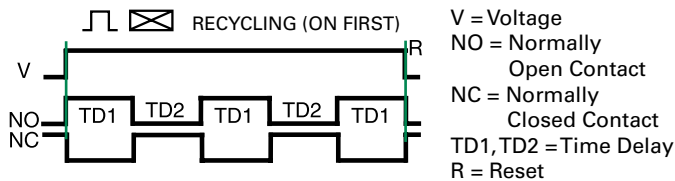

Specifications

Time Delay Range	0.1s - 100m in 5 adjustable ranges or fixed
Repeat Accuracy	±0.5% or 20ms, whichever is greater
Tolerance (Factory Calibration)	≤ ± 5%
Reset Time	≤ 150ms
Time Delay vs Temp. & Voltage	≤ ±5%
Input Voltage	12, 24 or 110VDC; 24, 120, or 230VAC
Tolerance	
12VDC & 24VDC/AC	-15% - 20%
110VDC, 120 or 230VAC	-20% - 10%
AC Line Frequency/DC Ripple	50/60 Hz / ≤ 10%
Power Consumption	AC ≤ 2VA; DC ≤ 2W
Output Type	Isolated relay contacts
Form	SPDT
Rating (at 40°C)	10A resistive @ 125VAC; 5A resistive @ 230VAC & 28VDC; 1/4 hp @ 125VAC 250VAC
Max. Switching Voltage	250VAC
Life (Operations)	Mechanical - 1 x 10 ⁷ ; Electrical - 1 x 10 ⁵
Protection	Encapsulated
Circuitry	≥ 1500V RMS input to output
Isolation Voltage	≥ 100 MΩ
Insulation Resistance	DC units are reverse polarity protected
Polarity	
Mechanical Mounting	Surface mount with one #10 (M5 x 0.8) screw
Dimensions	H 50.8 mm (2"); W 50.8 mm (2"); D 30.7 mm (1.21")
Termination	0.25 in. (6.35 mm) male quick connect terminals
Environmental Operating/Storage Temperature	-20° to 60°C / -40° to 85°C
Humidity	95% relative, non-condensing
Weight	≈ 2.6 oz (74 g)

KRDR SERIES



Description

The KRDR Series is a compact time-delay relay measuring only 2 in. (50.8 mm) square. Its solid-state timing circuit provides excellent repeat accuracy and stability. Encapsulation protects against shock, vibration, and humidity. The KRDR Series is a cost effective recycling timer for OEM applications that require small size, isolation, reliability, and long life.

Operation (Recycling - ON Time First)

Upon application of input voltage, the output relay energizes and the T2 ON time begins. At the end of the ON time, the output de-energizes and the T1 OFF time begins. At the end of the OFF time, the output relay energizes and the cycle repeats as long as input voltage is applied

Reset: Removing input voltage resets the output and the time delays, and returns the sequence to the ON time.

Operation (Recycling - OFF Time First)

Upon application of input voltage, the T1 OFF time begins. At the end of the OFF time, the T2 ON time begins and the load energizes. At the end of the ON time the load de-energizes, and the cycle repeats until input voltage is removed.

Reset: Removing input voltage resets the output and the sequence to the OFF time.

Wiring Diagram

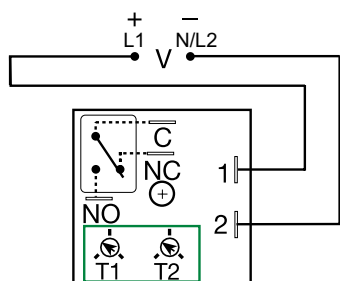

V = Voltage
C = Common
NO = Normally Open
NC = Normally Closed
T1 = OFF Time
T2 = ON Time

A knob is supplied for adjustable units.

For dimensional drawing see: Appendix, page 512, Figure 16.

Features & Benefits

FEATURES	BENEFITS
Compact design and independent adjustment of ON and OFF times	Provides greater flexibility for OEM applications and reduces component and labor costs
Microcontroller based	Repeat Accuracy + / - 0.5%, Factory calibration + / - 5%
Isolated, 10A, SPDT output contacts	Allows control of loads for AC or DC voltages
Encapsulated	Protects against shock, vibration, and humidity

Ordering Information

MODEL	INPUT VOLT.	ADJUST.	T2 ON TIME	FIRST DELAY	T1 OFF TIME
KRDR115MB25M	12VDC	Fixed	5m	Off time	25m
KRDR120A0	12VDC	Adjustable	0.1 - 10s	On time	0.1 - 10s
KRDR121A1	12VDC	Adjustable	1 - 100s	On time	1 - 100s
KRDR320B0	24VDC	Adjustable	0.1 - 10s	Off time	0.1 - 10s
KRDR321A4	24VDC	Adjustable	1 - 100s	On time	1 - 100m
KRDR321B4	24VDC	Adjustable	1 - 100s	Off time	1 - 100m
KRDR420A3	120VAC	Adjustable	0.1 - 10s	On time	0.1 - 10m
KRDR421A4	120VAC	Adjustable	1 - 100s	On time	1 - 100m
KRDR424A0	120VAC	Adjustable	1 - 100m	On time	0.1 - 10s
KRDR424A4	120VAC	Adjustable	1 - 100m	On time	1 - 100m
KRDR440.5SA0	120VAC	On time fixed	0.5s	On time	0.1 - 10s

If you don't find the part you need, call us for a custom product 800-843-8848

Accessories



P1023-6 Mounting bracket

The 90° orientation of mounting slots makes installation/removal of modules quick and easy.



P1015-13 (AWG 10/12), P1015-64 (AWG 14/16) Female Quick Connect

These 0.25 in. (6.35 mm) female terminals are constructed with an insulator barrel to provide strain relief.



P1015-18 Quick Connect to Screw Adapter

Screw adapter terminal designed for use with all modules with 0.25 in. (6.35 mm) male quick connect terminals.



C103PM (AL) DIN Rail

35 mm aluminum DIN rail available in a 36 in. (91.4 cm) length.



P1023-20 DIN Rail Adapter

Allows module to be mounted on a 35 mm DIN type rail with two #10 screws.

KRDR SERIES

Output Current/Ambient Temperature

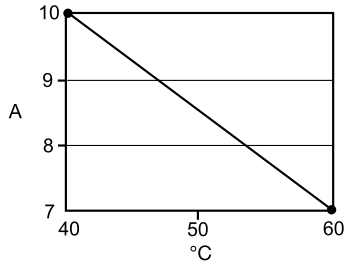

Function Diagrams

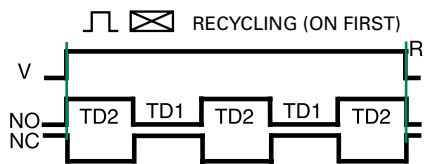

V = Voltage
NO = Normally Open Contact
NC = Normally Closed Contact
T1 = OFF Time
T2 = ON Time
R = Reset

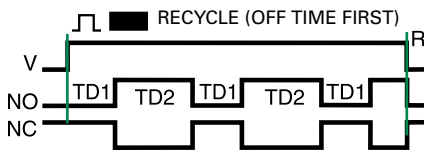

Specifications

Time Delay Range	0.1s - 1000m in 6 adjustable ranges or fixed
Repeat Accuracy	±0.5 % or 20ms, whichever is greater
Tolerance (Factory Calibration)	≤ ±5%
Reset Time	≤ 150ms
Time Delay vs Temp. & Voltage	≤ ±5%
Input Voltage	12, 24 or 110VDC; 24, 120 or 230VAC
Tolerance 12VDC & 24VDC/AC	-15% - 20%
110VDC & 120 or 230VAC	-20% - 10%
AC Line Frequency/DC Ripple	50/60 Hz / ≤ 10%
Power Consumption	AC ≤ 2VA; DC ≤ 2W
Output Type	Isolated relay contacts
Form	SPDT
Rating (at 40°C)	10A resistive @ 125VAC; 5A resistive @ 230VAC & 28VDC; 1/4 hp @ 125VAC
Max. Switching Voltage Life (Operations)	250VAC Mechanical - 1 x 10 ⁷ ; Electrical - 1 x 10 ⁵
Protection Circuitry	Encapsulated
Isolation Voltage	≥ 1500V RMS input to output
Insulation Resistance	≥ 100 MΩ
Polarity	DC units are reverse polarity protected
Mechanical Mounting	Surface mount with one #10 (M5 x 0.8) screw
Dimensions	H 50.8 mm (2"); W 50.8 mm (2"); D 30.7 mm (1.21")
Termination	0.25 in. (6.35 mm) male quick connect terminals
Environmental Operating/Storage Temperature	-20° to 60°C / -40° to 85°C
Humidity	95% relative, non-condensing
Weight	≈ 2.6 oz (74 g)

KSD3 SERIES

Recycling Flasher



Description

The KSD3 Series Digi-Timer is a cost effective approach for ON/OFF recycling applications. The on time is equal to the off time. An adjustment of the R_T will change the time delays of both on and off times. This series is designed for general purpose commercial and industrial applications where a small, cost effective, reliable, solid-state timer is required. The factory calibration for fixed time delays is within 5% of the target time delay. The repeat accuracy, under stable conditions, is 0.5% of the selected time delay. This series is designed for popular AC and DC voltages. Time delays of 0.1 seconds to 1000 minutes are available in 6 ranges. The output is rated 1A steady and 10A inrush. The modules are totally solid state and encapsulated to protect the electronic circuitry.

Operation (Recycling Flasher - ON Time First)

Upon application of input voltage, the output energizes and the T1, ON time begins. At the end of the ON time, the output de-energizes and the T2 OFF time begins. At the end of the OFF time, the output energizes and the cycle repeats as long as input voltage is applied.

Reset: Removing input voltage resets the output and time delays, and returns the sequence to the ON time.

Operation (Recycling Flasher - OFF Time First)

Upon application of input voltage, the T2 OFF time begins. At the end of the OFF time, the T1 ON time begins and the load energizes. At the end of the ON time the load de-energizes, and the cycle repeats until input voltage is removed.

Reset: Removing input voltage resets the output and time delays and the sequence to the OFF time.

Wiring Diagram

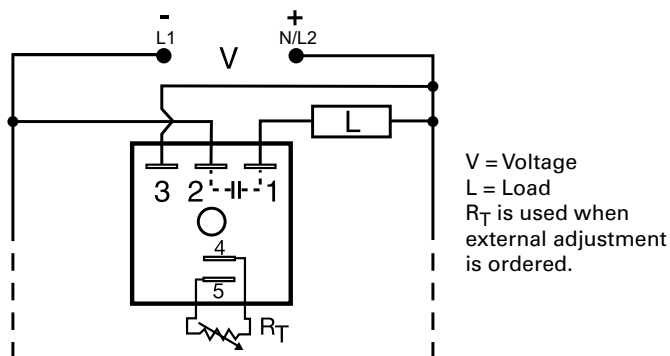

For dimensional drawing see: Appendix, page 512, Figure 16.

Features & Benefits

FEATURES	BENEFITS
Microcontroller based	Repeat Accuracy +/- 0.5%, +/- 5% time delay accuracy
Compact, low cost design	Allows flexibility for OEM applications
1A Steady solid-state output, 10A inrush	Provides 100 million operations in typical conditions.
Totally solid state and encapsulated	No moving parts to arc and wear out over time and encapsulated to protect against shock, vibration, and humidity

Accessories



P1004-95, P1004-95-X Versa-Pot

Panel mountable, industrial potentiometer recommended for remote time delay adjustment.



P1023-6 Mounting bracket

The 90° orientation of mounting slots makes installation/removal of modules quick and easy.



P0700-7 Versa-Knob

Designed for 0.25 in (6.35 mm) shaft of Versa-Pot. Semi-gloss industrial black finish.

Ordering Information

MODEL	INPUT VOLTAGE	ADJUSTMENT	TIME DELAY	OPERATING SEQUENCE
KSD3120A	12VDC	External	0.1 - 10s	ON time first
KSD3310.1SA	24VDC	Fixed	0.1s	ON time first
KSD3415MA	120VAC	Fixed	5m	ON time first
KSD3432A	120VAC	Onboard	10 - 1000s	ON time first

If you don't find the part you need, call us for a custom product 800-843-8848

KSD3 SERIES

Accessories



P1015-64 (AWG 14/16) Female Quick Connect
These 0.25 in. (6.35 mm) female terminals are constructed with an insulator barrel to provide strain relief.



P1015-18 Quick Connect to Screw Adapter
Screw adapter terminal designed for use with all modules with 0.25 in. (6.35 mm) male quick connect terminals.



C103PM (AL) DIN Rail
35 mm aluminum DIN rail available in a 36 in. (91.4 cm) length.



P1023-20 DIN Rail Adapter
Allows module to be mounted on a 35 mm DIN type rail with two #10 screws.

External Resistance vs. Time Delay

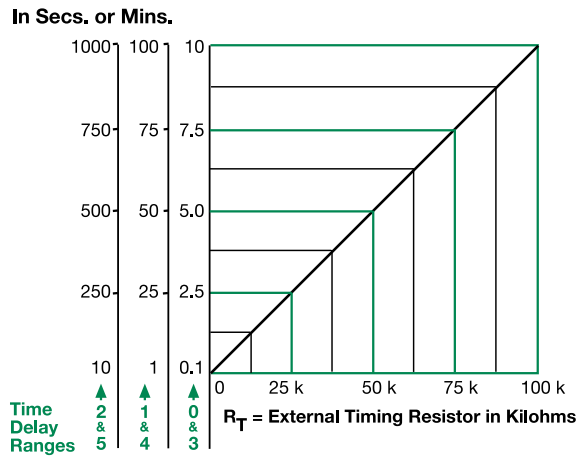

This chart applies to externally adjustable part numbers.
The time delay is adjustable over the time delay range selected by varying the resistance across the R_T terminals; as the resistance increases the tie delay increases.
When selecting an external R_T , add the tolerances of the timer and the R_T for the full time range adjustment.
Examples: 1 to 50 S adjustable time delay, select time delay range 1 and a 50 K ohm R_T . For 1 to 100 S use a 100 K ohm R_T .

Specifications

Time Delay	
Range	0.1s - 1000m in 6 adjustable ranges or fixed
Repeat Accuracy	±0.5% or 20ms, whichever is greater
Tolerance (Factory Calibration)	≤ ± 5%
Reset Time	≤ 150ms
Time Delay vs. Temperature & Voltage	≤ ±10%
Input Voltage	24 or 120VAC; 12 or 24VDC
Tolerance	±20%
AC Line Frequency	50/60 Hz
Power Consumption	AC ≤ 2VA; DC ≤ 1W
Output Type	Solid state
Maximum Load Current	1A steady state, 10A inrush at 60°C
OFF State Leakage Current	AC ≅ 5mA @ 230VAC; DC ≅ 1mA
Voltage Drop	AC ≅ 2.5V @ 1A; DC ≅ 1V @ 1A
DC Operation	Negative switching only
Protection Circuitry	Encapsulated
Dielectric Breakdown	≥ 2000V RMS terminals to mounting surface
Insulation Resistance	≥ 100 MΩ
Polarity	DC units are reverse polarity protected
Mechanical Mounting	Surface mount with one #10 (M5 x 0.8) screw
Dimensions	H 50.8 mm (2"); W 50.8 mm (2"); D 30.7 mm (1.21")
Termination	0.25 in. (6.35 mm) male quick connect terminals
Environmental Operating/Storage Temperature	-40° to 60°C / -40° to 85°C
Humidity	95% relative, non-condensing
Weight	≅ 2.4 oz (68 g)

Function Diagrams

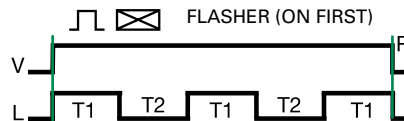

ON time plus OFF time equals one complete flash.

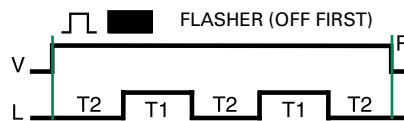

V = Voltage
L = Load
T1 = ONTime
T2 = OFFTime
T1 ≅ T2
R = Reset

KSDR SERIES



Wiring Diagram

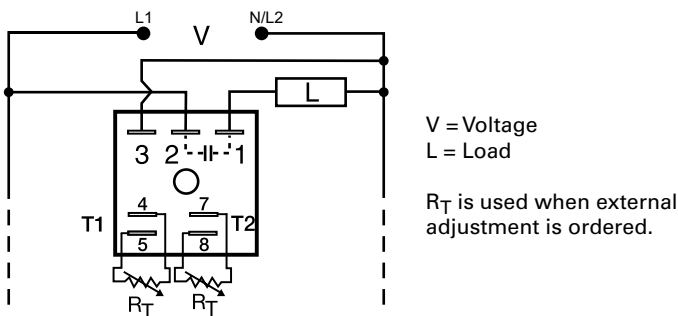

For dimensional drawing see: Appendix, page 512, Figure 16.

Description

The KSDR Series offers independent time adjustment of both delay periods. The KSDR Series is recommended for air drying, automatic oiling, life testing, chemical metering, and automatic duty cycling. This series is designed for general purpose commercial and industrial applications where a small, cost effective, reliable, solid-state timer is required. The factory calibration for fixed time delays is within ± 5% of the target delay. The repeat accuracy, under stable conditions, is 0.5% of the selected time delay. This series is designed for input voltages of 24, 120 or 230VAC. Time delays of 0.1 seconds to 1000 minutes are available in 6 ranges. The output is rated 1A steady and 10A inrush. The modules are totally solid state and encapsulated to protect the electronic circuitry.

Operation (Recycling - ON Time First)

Upon application of input voltage, the output energizes and the T1, ON time begins. At the end of the ON time, the output de-energizes and the T2, OFF time begins. At the end of the OFF time, the output energizes and the cycle repeats as long as input voltage is applied.

Reset: Removing input voltage resets the output and time delays, and returns the sequence to T1 ON time.

Operation (Recycling - OFF Time First)

Upon application of input voltage, the T2 OFF time begins. At the end of the OFF time, the T1 ON time begins and the load energizes. At the end of T1, T2 begins and the load de-energizes. This cycle repeats until input voltage is removed.

Reset: Removing input voltage resets the output and the sequence to T2 OFF time.

Features & Benefits

FEATURES	BENEFITS
Microcontroller based	Repeat Accuracy + / - 0.5%, Factory calibration + / - 5%
1A steady, 10A inrush solid-state output	Provides 100 million operations in typical conditions
Totally solid state and encapsulated	No moving parts to arc and wear out over time and encapsulated to protect against shock, vibration, and humidity
Wide operating temperature range: -40° to 75°C	Reliable in demanding commercial and industrial applications
Compact, low cost design measuring 2 in. (50.8mm) square	Allows flexibility for OEM applications

Ordering Information

MODEL	INPUT VOLTAGE	T1 ON TIME	FIRST DELAY	T2 OFF TIME
KSDR40A0	120VAC	0.1 - 10s	On time	0.1 - 10s
KSDR42A4	120VAC	10 - 1000s	On time	1 - 100m

If you don't find the part you need, call us for a custom product 800-843-8848

12 TIME DELAY RELAYS

KSDR SERIES

Accessories



P1004-95, P1004-95-X Versa-Pot
Panel mountable, industrial potentiometer recommended for remote time delay adjustment.



P1023-6 Mounting bracket
The 90° orientation of mounting slots makes installation/removal of modules quick and easy.



P0700-7 Versa-Knob
Designed for 0.25 in. (6.35 mm) shaft of Versa-Pot. Semi-gloss industrial black finish.



P1015-13 (AWG 10/12), **P1015-64** (AWG 14/16), **P1015-14** (AWG 18/22) **Female Quick Connect**
These 0.25 in. (6.35 mm) female terminals are constructed with an insulator barrel to provide strain relief.



P1015-18 Quick Connect to Screw Adapter
Screw adapter terminal designed for use with all modules with 0.25 in. (6.35 mm) male quick connect terminals.



C103PM (AL) DIN Rail
35 mm aluminum DIN rail available in a 36 in. (91.4 cm) length.



P1023-20 DIN Rail Adapter
Allows module to be mounted on a 35 mm DIN type rail with two #10 screws.

External Resistance vs. Time Delay

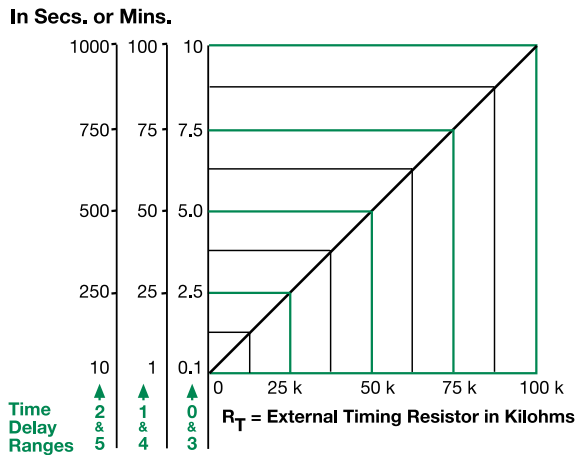

This chart applies to externally adjustable part numbers.
The time delay is adjustable over the time delay range selected by varying the resistance across the R_T terminals; as the resistance increases the tie delay increases.

When selecting an external R_T , add the tolerances of the timer and the R_T for the full time range adjustment.

Examples: 1 to 50 S adjustable time delay, select time delay range 1 and a 50 K ohm R_T . For 1 to 100 S use a 100 K ohm R_T .

Function Diagrams

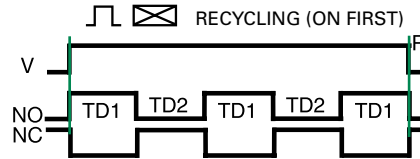

V = Voltage
NO = Normally Open Contact
NC = Normally Closed Contact
TD1, TD2 = Time Delay
R = Reset

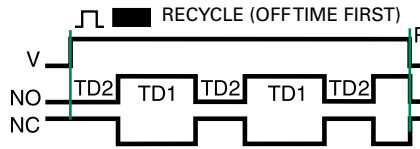

Specifications

Time Delay

Range 0.1s - 1000ms in 6 ranges
Repeat Accuracy ±0.5% or 20ms, whichever is greater

Tolerance (Factory Calibration) ≤ ±5%

Reset Time ≤ 150ms

Time Delay vs Temp. & Voltage ≤ ±10%

Input

Voltage 24, 120, or 230VAC

Tolerance ±20%

AC Line Frequency 50/60 Hz

Power Consumption ≤ 2VA

Output

Type Solid state

Rating 1A steady state, 10A inrush at 60°C

Voltage Drop ≈ 2.5V @ 1A

OFF State Leakage Current ≈ 5mA @ 230VAC

Protection

Circuitry Encapsulated

Dielectric Breakdown ≥ 2000V RMS terminals to mounting surface

Insulation Resistance ≥ 100 MΩ

Mechanical

Mounting

Surface mount with one #10 (M5 x 0.8) screw

Dimensions

H 50.8 mm (2"); **W** 50.8 mm (2");

D 30.7 mm (1.21")

0.25 in. (6.35 mm) male quick connect terminals

Termination

Environmental

Operating/Storage

Temperature

-40° to 75°C / -40° to 85°C

Humidity

95% relative, non-condensing

Weight

≈ 2.4 oz (68 g)

KSPD SERIES

Solid State Timer



Description

The KSPD Series is a factory programmed module available with 1 of 12 standard dual functions. The time delays can be factory fixed, externally or onboard adjustable, or a combination of fixed and adjustable. The 1A steady, 10A inrush rated solid-state output provides 100 million operations, typical. Its microcontroller timing circuit provides excellent repeat accuracy and stability. Encapsulation protects against shock, vibration, and humidity. The KSPD Series is a cost effective approach for OEM applications that require small size and long life.

Features & Benefits

FEATURES	BENEFITS
Microcontroller based	Repeat Accuracy +/- 0.5%
Compact design	Allows flexibility for OEM applications
1A steady, 10A inrush solid-state output	Provides 100 million operations in typical conditions.
Totally solid state and encapsulated	No moving parts to arc and wear out over time and encapsulated to protect against shock, vibration, and humidity

Wiring Diagram

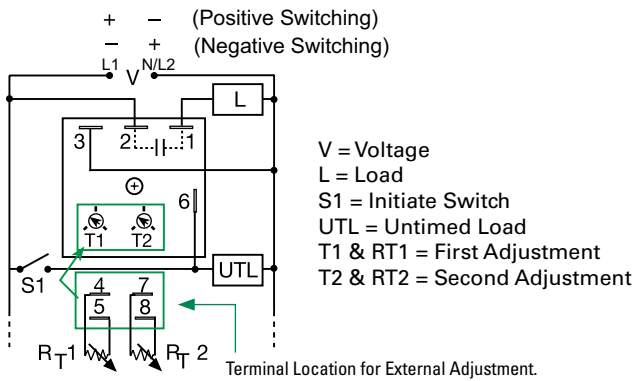

For dimensional drawing see: Appendix, page 512, Figure 16.

Accessories



P1004-95, P1004-95-X Versa-Pot
Panel mountable, industrial potentiometer recommended for remote time delay adjustment.



P1023-6 Mounting bracket
The 90° orientation of mounting slots makes installation/removal of modules quick and easy.



P0700-7 Versa-Knob
Designed for 0.25 in. (6.35 mm) shaft of Versa-Pot. Semi-gloss industrial black finish.



P1015-64 (AWG 14/16) Female Quick Connect
These 0.25 in. (6.35 mm) female terminals are constructed with an insulator barrel to provide strain relief.



C103PM (AL) DIN Rail
35 mm aluminum DIN rail available in a 36 in. (91.4 cm) length.



P1023-20 DIN Rail Adapter
Allows module to be mounted on a 35 mm DIN type rail with two #10 screws.

Ordering Information

MODEL	INPUT	ADJUSTMENT 1	TIME DELAY 1	ADJUSTMENT 2	TIME DELAY 2	FUNCTION
KSPDA2222RXE	24 to 240VAC	Onboard	1-100s	Onboard	1-100s	Recycling/On Time First
KSPDP110M18SRXE	12 to 120VDC positive switching	Fixed	10 mins	Fixed	8s	Recycling/On Time First

If you don't find the part you need, call us for a custom product 800-843-8848

KSPD SERIES

Function Diagrams

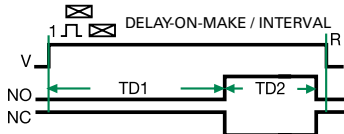
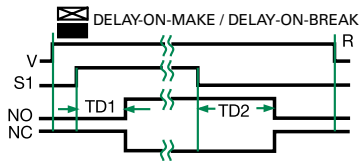
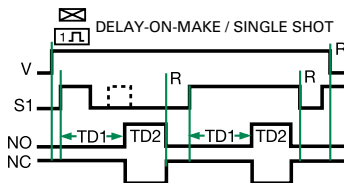
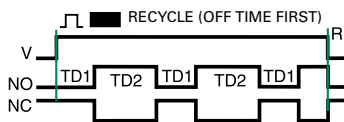
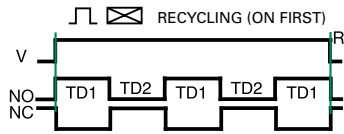

V = Voltage
S1 = Initiate Switch
NO = Normally Open Contact
NC = Normally Closed Contact
TD1, TD2 = Time Delay
R = Reset
— = Undefined Time

Specifications

Time Delay

Type

Range

Microcontroller circuitry
0.1s - 1000h in 9 adjustable ranges or fixed (to 999)

Repeat Accuracy

Tolerance

(Factory Calibration)

Reset Time

Initiate Time

Time Delay vs Temp.

& Voltage

±0.5% or 20ms, whichever is greater

≤ ±2%

≤ 150ms
≤ 20ms; ≤ 1500 operations per minute

≤ ±2%

Input

Voltage

Tolerance

AC Line Frequency/DC Ripple

Power Consumption

12 to 120VDC; 24 to 240VAC

≤ ±15%

50/60Hz / ≤ 10%

AC ≤ 2VA; DC ≤ 1W

Output

Type

Rating

Voltage Drop

OFF State Leakage Current

Solid-state output

1A steady, 10A inrush for 16ms

AC ≅ 2.5V @ 1A; DC ≅ 1V @ 1A

AC ≅ 5mA @ 230VAC; DC ≅ 1mA

Protection

Circuitry

Dielectric Breakdown

Insulation Resistance

Polarity

Encapsulated

≥ 2000V rms terminals to mounting surface

≥ 100 MΩ

DC units are reverse polarity protected

Mechanical

Mounting

Dimensions

Surface mt. with one #10 (M5 x 0.8) screw

H 50.8 mm (2"); **W** 50.8 mm (2");

D 30.7 mm (1.21")

0.25 in. (6.35 mm) male quick connects

Termination

Environmental

Operating/Storage

Temperature

Humidity

Weight

-40° to 60°C / -40° to 85°C

95% relative, non-condensing

≅ 2.4 oz (68 g)

RS SERIES



Description

The RS Series is a solid-state, encapsulated, recycling timer designed for tough industrial environments. It is used by many testing labs as a life cycle tester; by others as a cycle controller. The RS Series has separate DIP switch adjustments for the on delay and the off delay. These make accurate adjustment possible the first time, every time. Time delays of 0.1 seconds to 1023 hours are available in 4 ranges.

Operation (Recycling - ON Time First)

Upon application of input voltage, the output energizes and the T1 ON time begins. At the end of the ON time, the output de-energizes and the T2 OFF time begins. At the end of the OFF time, the output energizes and the cycle repeats as long as input voltage is applied.

Reset: Removing input voltage resets the output and time delays, and returns the sequence to the ON time.

Operation (Recycling - OFF Time First)

Upon application of input voltage, the T2 OFF time begins. At the end of the OFF time, the output energizes and the T1 ON time begins. At the end of the ON time, the output de-energizes and the cycle repeats as long as input voltage is applied.

Reset: Removing input voltage resets the output and time delays, and returns the sequence to the OFF time.

Wiring Diagram

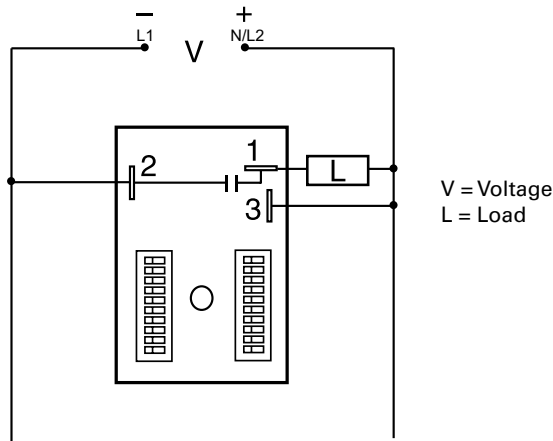

For dimensional drawing see: Appendix, page 512, Figure 17.

Features & Benefits

FEATURES	BENEFITS
Microcontroller based	Repeat Accuracy +/- 0.1%, Setting accuracy +/- 2%
1A steady, 10A inrush solid-state output	Provides 100 million operations in typical conditions
Totally solid state and encapsulated	No moving parts to arc and wear out over time and encapsulated to protect against shock, vibration, and humidity
ON and OFF time delay settings	Independent adjustment provides greater timing flexibility
DIP switch adjustment	Provides first time setting accuracy

Ordering Information

MODEL	INPUT VOLTAGE	FIRST DELAY	T1 ON TIME	T2 OFF TIME	MODEL	INPUT VOLTAGE	FIRST DELAY	T1 ON TIME	T2 OFF TIME
RS1A11	12VDC	On time	0.1 - 102.3s in 0.1s increments	0.1 - 102.3s in 0.1s increments	RS4A22	120VAC	On time	0.1 - 102.3m in 0.1m increments	0.1 - 102.3m in 0.1m increments
RS2B44	24VAC	Off time	1 - 1023h in 1h increments	1 - 1023h in 1h increments	RS4A24	120VAC	On time	0.1 - 102.3m in 0.1m increments	1 - 1023h in 1h increments
RS4A11	120VAC	On time	0.1 - 102.3s in 0.1s increments	0.1 - 102.3s in 0.1s increments	RS4A33	120VAC	On time	1 - 1023m in 1m increments	1 - 1023m in 1m increments
RS4A12	120VAC	On time	0.1 - 102.3s in 0.1s increments	0.1 - 102.3m in 0.1m increments	RS4B12	120VAC	Off time	0.1 - 102.3s in 0.1s increments	0.1 - 102.3m in 0.1m increments
RS4A13	120VAC	On time	0.1 - 102.3s in 0.1s increments	1 - 1023m in 1m increments	RS6A13	230VAC	On time	0.1 - 102.3s in 0.1s increments	1 - 1023m in 1m increments

If you don't find the part you need, call us for a custom product 800-843-8848

12 TIME DELAY RELAYS

RS SERIES

Accessories



P1023-6 Mounting bracket
The 90° orientation of mounting slots makes installation/removal of modules quick and easy.



P1015-64 (AWG 14/16) Female Quick Connect
These 0.25 in. (6.35 mm) female terminals are constructed with an insulator barrel to provide strain relief.



P1015-18 Quick Connect to Screw Adapter
Screw adapter terminal designed for use with all modules with 0.25 in. (6.35 mm) male quick connect terminals.



C103PM (AL) DIN Rail
35 mm aluminum DIN rail available in a 36 in. (91.4 cm) length.



P1023-20 DIN Rail Adapter
Allows module to be mounted on a 35 mm DIN type rail with two #10 screws.

Adjustment Switch Operation

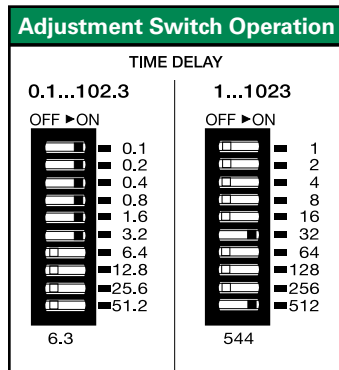

Function Diagrams

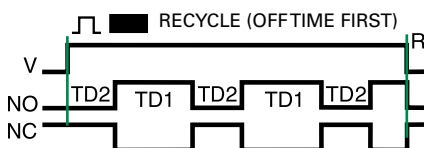
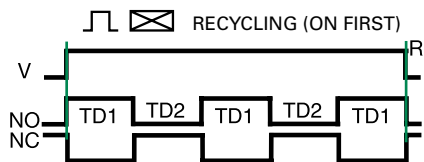

V = Voltage
NO = Normally Open Contact
NC = Normally Closed Contact
TD1, TD2 = Time Delay
R = Reset

Specifications

Time Delay Range*	0.1 - 102.3s in 0.1s increments 0.1 - 102.3m in 0.1m increments 1 - 1023m in 1m increments 1 - 1023h in 1h increments
Repeat Accuracy	±0.1% or 20ms, whichever is greater
Setting Accuracy	≤ ±2% or 20ms, whichever is greater
Reset Time	≤ 150ms
Time Delay vs Temp. & Voltage	≤ ±2%
Input Voltage	12, or 24VDC; 24, 120, or 230VAC
Tolerance	±20%
AC Line Frequency/DC Ripple	50/60 Hz / ≤ ±10%
Power Consumption	AC ≤ 2VA; DC ≤ 1W
Output Type	Solid state
Maximum Load Current	1A steady state, 10A inrush at 60°C
OFF State Leakage Current	AC ≅ 5mA @ 230VAC; DC ≅ 1mA
Voltage Drop	AC ≅ 2.5V @ 1A; DC ≅ 1V @ 1A
Protection	
Circuitry	Encapsulated
Dielectric Breakdown	≥ 2000V RMS terminals to mounting surface
Insulation Resistance	≥ 100 MΩ
Polarity	DC units are reverse polarity protected
Mechanical	
Mounting	Surface mount with one #10 (M5 x 0.8) screw
Dimensions	H 76.7 mm (3"); W 50.8 mm (2"); D 38.1 mm (1.5")
Termination	0.25 in. (6.35 mm) male quick connect terminals
Environmental	
Operating/Storage Temperature	-40° to 75°C / -40° to 85°C
Humidity	95% relative, non-condensing
Weight	≅ 3.9 oz (111 g)

*For CE approved applications, power must be removed from the unit when a switch position is changed.

TDR SERIES

Relay Output, Recycling Time Delay Relay



8-PIN

Description

The TDR Series of time-delay relays are comprised of digital circuitry and an isolated, 10A relay output. The ON and OFF delays are selected by means of two, ten position binary switches, which allow the setting of the desired delay to be precise every time.

Operation (Recycling - ON Time First)

Upon application of input voltage, the green LED glows, the output relay is energized, the red LED glows, and the T1 ON time begins. At the end of the ON time, the output de-energizes, the red LED turns OFF and the T2, OFF time begins. At the end of the OFF time, the output relay energizes and the cycle repeats as long as input voltage is applied.

Reset: Removing input voltage resets the output and time delays, and returns the sequence to the first delay.

Operation (Recycling - OFF Time First)

Upon application of input voltage, the green LED glows, the T1 OFF time begins, the load is OFF. At the end of the OFF time, the T2 ON time begins, the load energizes, and the red LED glows. At the end of the ON time the load de-energizes and the red LED turns OFF. The cycle repeats until input voltage is removed.

Reset: Removing input voltage resets the output and the sequence to the OFF time.

Wiring Diagram

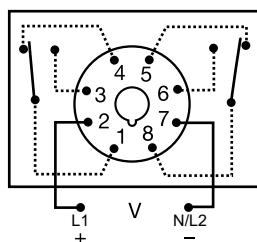

Relay contacts are isolated

For dimensional drawing see: Appendix, page 512, Figure 23.

Features & Benefits

FEATURES	BENEFITS
ON & OFF time delay settings	Independent adjustment allows for greater flexibility
3 Time Ranges Available (0.1s to 2.8h)	Makes it versatile for use in many applications
Microcontroller based	Repeat Accuracy +/- 0.1% or 20 ms, whichever is greater; Setting Accuracy +/- 2% or 50 ms, whichever is greater
DIP switch adjustment	Provides first time setting accuracy
Isolated output contacts	Allows control of loads for AC or DC voltages
LED indication (select models)	Provides visual indication of relay status

Ordering Information

MODEL	INPUT VOLTAGE	LED	SEQUENCE	ON TIME (SEC)	OFF TIME (SEC)
TDR1A22	12VDC		ON time first	1-1023 in 1s increments	1-1023 in 1s increments
TDR2A23	24VAC	X	ON time first	1-1023 in 1s increments	10-10230 in 10s increments
TDR4A11	120VAC	X	ON time first	0.1-102.3 in 0.1s increments	0.1-102.3 in 0.1s increments
TDR4A12	120VAC	X	ON time first	0.1-102.3 in 0.1s increments	1-1023 in 1s increments
TDR4A13	120VAC	X	ON time first	0.1-102.3 in 0.1s increments	10-10230 in 10s increments
TDR4A22	120VAC	X	ON time first	1-1023 in 1s increments	1-1023 in 1s increments
TDR4A23	120VAC	X	ON time first	1-1023 in 1s increments	10-10230 in 10s increments
TDR4A33	120VAC	X	ON time first	10-10230 in 10s increments	10-10230 in 10s increments
TDR4B22	120VAC	X	OFF time first	1-1023 in 1s increments	1-1023 in 1s increments
TDR4B23	120VAC	X	OFF time first	1-1023 in 1s increments	10-10230 in 10s increments
TDR6A22	230VAC	X	ON time first	1-1023 in 1s increments	1-1023 in 1s increments

If you don't find the part you need, call us for a custom product 800-843-8848

TDR SERIES

Accessories



BZ1 Front Panel Mount Kit
Provides an easy method of through-the-panel mounting of 8- or 11-pin plug-in timers, flashers, and other controls.



NDS-8 Octal 8-pin Socket
8-pin 35mm DIN rail or surface mount. Rated at 10A @ 300VAC. Surface mounted with two #6 (M 3.5 x 0.6) screws or snaps onto a 35 mm DIN rail. Uses PSC8 hold-down clips.



PSC8 Hold-down Clips
Securely mounts plug-in controls in any position. Provides protection against vibration. Use with NDS-8 Octal Socket. Sold in pairs.



C103PM (AL) DIN Rail
35 mm aluminum DIN rail available in a 36 in. (91.4 cm) length.

Binary Switch Operation

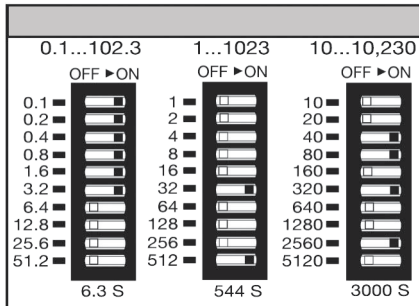

** For CE approved applications, power must be removed from the unit when a switch position is changed.

Function Diagram

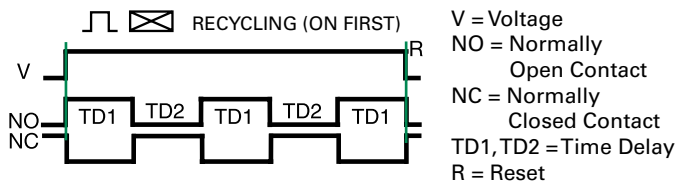

Specifications

Time Delay Type
Range**

Digital integrated circuitry
0.1 - 102.3s in 0.1s increments
1 - 1023s in 1s increments
10 - 10,230s in 10s increments

Repeat Accuracy
Setting Accuracy
Reset Time
Recycle Time
Time Delay vs Temp. & Voltage

±0.1% or 20ms, whichever is greater
±2% or 50ms, whichever is greater
≤ 50ms
≤ 150ms
±5%

Input Voltage Tolerance
12VDC & 24VDC/AC
110 to 230VAC/DC
AC Line Frequency/DC Ripple
Power Consumption
Input LED Indicator

12, 24/28, or 110VDC; 24, 120, or 230VAC
-15% - 20%
-20% - 10%
50/60 Hz/≤10%
≤ 3.25W
Green; on when input voltage is applied

Output Type
Form
Rating

Electromechanical relay
DPDT
10A resistive @ 120/240VAC & 28VDC;
1/3 hp @ 120/240VAC

Life
Max. Switching Voltage
Relay LED Indicator

Mechanical - 1 x 10⁷; Electrical - 1 x 10⁶
250VAC
Red; ON when output relay energizes

Protection Isolation Voltage
Insulation Resistance
Polarity

≥ 1500V RMS input to output
≥ 100 MΩ
DC units reverse polarity protected

Mechanical Mounting
Dimensions

Plug-in socket
H 81.3 mm (3.2"); **W** 60.7 mm (2.39");
D 45.2 mm (1.78")
Octal 8-pin plug-in

Termination Environmental
Operating/Storage Temperature
Weight

-20° to 65°C/-30° to 85°C
≈ 6 oz (170 g)

THD3C42A0



Wiring Diagram

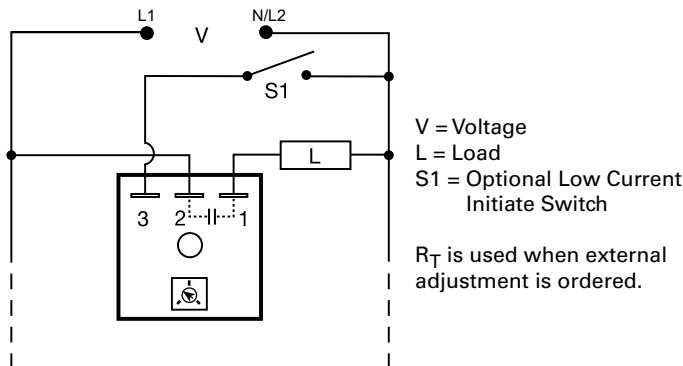

For dimensional drawing see: Appendix, page 512, Figure 19.

Description

The THD3C42A0 combines accurate timing circuitry with high power, solid-state switching. It can switch motors, lamps, and heaters directly without a contactor. The THD3C42A0 has equal on and off time delays. A single R_T sets both time delays. You can reduce labor, component cost, and increase reliability with these small, easy-to-use, Digi-Power timers.

Operation (Recycling Flasher - ON Time First)

Upon application of input voltage, the output energizes and the T1 ON time begins. At the end of the ON time, the output de-energizes and the T2 OFF time begins. At the end of the OFF time, the output energizes and the cycle repeats as long as input voltage is applied.

Reset: Removing input voltage resets the output and time delays, and returns the sequence to T1 ON time.

Operation (Recycling Flasher - OFF Time First)

Upon application of input voltage, the T2 OFF time begins. At the end of the OFF time, the T1 ON time begins and the load energizes. At the end of T1, T2 begins and the load de-energizes. This cycle repeats until input voltage is removed.

Reset: Removing input voltage resets the output and the sequence to T2 OFF time.

Features & Benefits

FEATURES	BENEFITS
Microcontroller based	Repeat Accuracy +/- 0.5%, Factory calibration +/- 1%
Compact, low cost design	Allows flexibility for OEM applications and reduces labor and component costs
High load currents up to 20A, 200A inrush	Allows direct operation of motors, lamps, and heaters without a contactor
Totally solid state and encapsulated	No moving parts to arc and wear out over time and encapsulated to protect against shock, vibration, and humidity
Metalized mounting surface	Facilitates heat transfer in high current applications

Accessories



P1004-95, P1004-95-X Versa-Pot

Panel mountable, industrial potentiometer recommended for remote time delay adjustment.



P0700-7 Versa-Knob

Designed for 0.25 in. (6.35 mm) shaft of Versa-Pot. Semi-gloss industrial black finish.



P1015-13 (AWG 10/12), P1015-64 (AWG 14/16) Female Quick Connect

These 0.25 in. (6.35 mm) female terminals are constructed with an insulator barrel to provide strain relief.



P1015-18 Quick Connect to Screw Adapter

Screw adapter terminal designed for use with all modules with 0.25 in. (6.35 mm) male quick connect terminals.

THD3C42A0

External Resistance vs. Time Delay

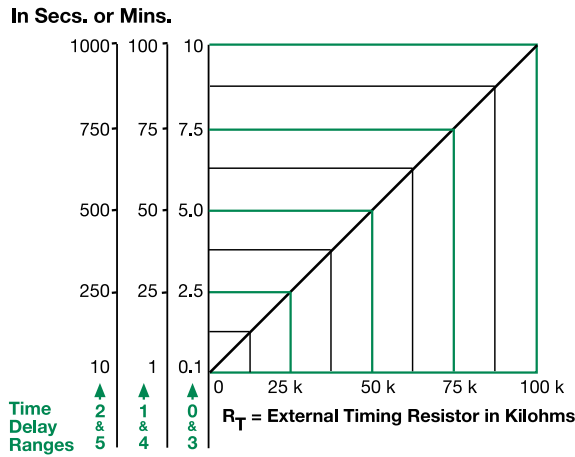

This chart applies to externally adjustable part numbers.
The time delay is adjustable over the time delay range selected by varying the resistance across the R_T terminals; as the resistance increases the time delay increases.

When selecting an external R_T , add the tolerances of the timer and the R_T for the full time range adjustment.

Examples: 1 to 50 S adjustable time delay, select time delay range 1 and a 50 K ohm R_T . For 1 to 100 S use a 100 K ohm R_T .

Function Diagrams

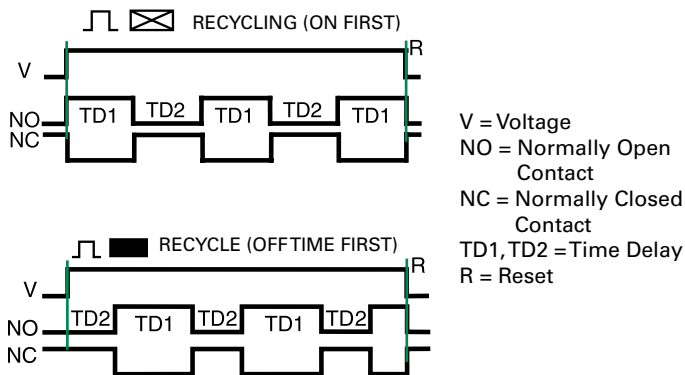

Specifications

Time Delay Range Adjustment	0.1s - 1000m in 6 adjustable ranges or fixed Single variable resistor changes both the on & off times equally	
Repeat Accuracy Tolerance (Factory Calibration)	±0.5% or 20ms, whichever is greater	
Reset Time	≤ 150ms	
Time Delay vs Temp. & Voltage	≤ ±2%	
Input Voltage	24, 120, or 230VAC	
Tolerance	±20%	
AC Line Frequency	50/60 Hz	
Power Consumption	≤ 2VA	
Output Type	Solid state	
Maximum Load Current	Steady State	Inrush**
	20A	200A
Minimum Load Current	100mA	
Voltage Drop	≈ 2.5V at rated current	
OFF State Leakage Current	≈ 5mA @ 230VAC	
Protection	Encapsulated	
Circuitry	≥ 2000V RMS terminals to mounting surface	
Dielectric Breakdown	≥ 100 MΩ	
Insulation Resistance		
Mechanical Mounting**	Surface mount with one #10 (M5 x 0.8) screw	
Dimensions	H 50.8 mm (2"); W 50.8 mm (2"); D 38.4 mm (1.51")	
Termination	0.25 in. (6.35 mm) male quick connect terminals	
Environmental Operating/Storage Temperature	-40° to 60°C / -40° to 85°C	
Humidity	95% relative, non-condensing	
Weight	≈ 3.9 oz (111 g)	

**Must be bolted to a metal surface using the included heat sink compound. The maximum mounting surface temperature is 90°C. Inrush: Non-repetitive for 16ms.

TSD3411S

Recycling Timer

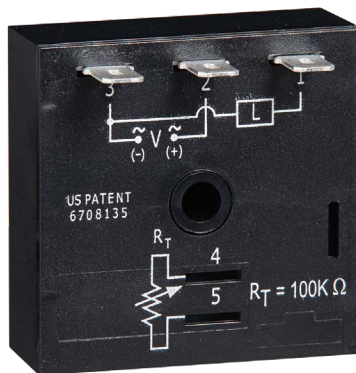

Description

The TSD3411S is a solid-state ON/OFF recycling timer with the on time always equal to the off time. When time delay is changed by the R_T , both the ON and the OFF periods are changed. The TSD Series is designed for more demanding commercial and industrial applications where small size, and accurate performance is required. The factory calibration for fixed time delays is within 1% of the target time delay. The repeat accuracy, under stable conditions, is 0.1% of the time delay. The TSD3411S is rated to operate over an extended temperature range. Time delays of 0.1 seconds to 100 hours are available. The output is rated 1A steady and 10A inrush. The modules are totally solid state and encapsulated to protect the electronic circuitry.

Operation (Recycling Flasher - ON Time First)

Upon application of input voltage, the output energizes and the T1, ON time begins. At the end of the ON time, the output de-energizes and the T2 OFF time begins. At the end of the OFF time, the output energizes and the cycle repeats as long as input voltage is applied.

Reset: Removing input voltage resets the output and time delays, and returns the sequence to the T1 ON time.

Wiring Diagram

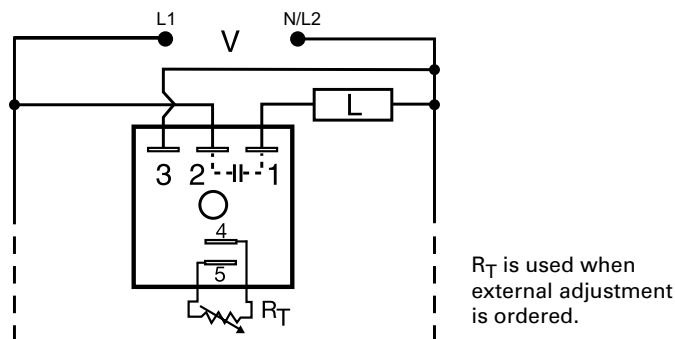

For dimensional drawing see: Appendix, page 512, Figure 16.

Features & Benefits

FEATURES	BENEFITS
Microcontroller based	Repeat Accuracy +/- 0.1%, +/- 1% time delay accuracy
Extended temperature range	Rated to 75°C operating temperature to withstand high heat applications.
Compact, low cost design	Allows flexibility for OEM applications
1A Steady solid-state output, 10A inrush	Provides 100 million operations in typical conditions.
Totally solid state and encapsulated	No moving parts to arc and wear out over time and encapsulated to protect against shock, vibration, and humidity

12

Accessories



P1004-95, P1004-95-X Versa-Pot
Panel mountable, industrial potentiometer recommended for remote time delay adjustment.



P1015-18 Quick Connect to Screw Adapter
Screw adapter terminal designed for use with all modules with 0.25 in. (6.35 mm) male quick connect terminals.



P1023-6 Mounting bracket
The 90° orientation of mounting slots makes installation/removal of modules quick and easy.



C103PM (AL) DIN Rail
35 mm aluminum DIN rail available in a 36 in. (91.4 cm) length.



P0700-7 Versa-Knob
Designed for 0.25 in (6.35 mm) shaft of Versa-Pot. Semi-gloss industrial black finish.



P1023-20 DIN Rail Adapter
Allows module to be mounted on a 35 mm DIN type rail with two #10 screws.



P1015-64 (AWG 14/16) Female Quick Connect
These 0.25 in. (6.35 mm) female terminals are constructed with an insulator barrel to provide strain relief.

TIME DELAY RELAYS

TSD3411S

External Resistance vs. Time Delay

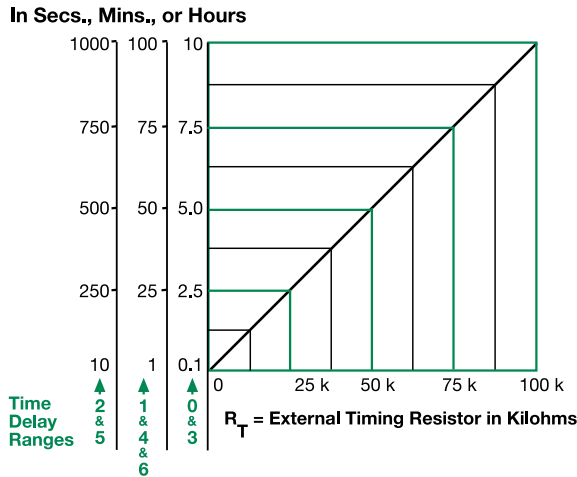

This chart applies to externally adjustable part numbers. The time delay is adjustable over the time delay range selected by varying the resistance across the R_T terminals; as the resistance increases the time delay increases. When selecting an external R_T, add the tolerances of the timer and the R_T for the full time range adjustment. **Examples:** 1 to 50 S adjustable time delay, select time delay range 1 and a 50 K ohm R_T. For 1 to 100 S use a 100 K ohm R_T.

Function Diagram

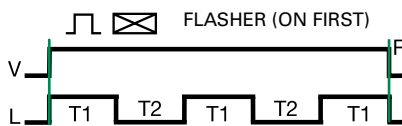

V = Voltage
L = Load
T1 = ON Time
T2 = OFF Time
T1 ≅ T2
R = Reset

ON time plus OFF time equals one complete flash.

Specifications

Time Delay	0.1s - 100h in 7 adjustable ranges
Range	±0.1% or 20ms, whichever is greater
Repeat Accuracy	
Tolerance (Factory Calibration)	≤ ±1%
Reset Time	≤ 150ms
Time Delay vs. Temperature & Voltage	≤ ±1%
Input	
Voltage	24, 120, or 230VAC
Tolerance	±20%
AC Line Frequency	50/60 Hz
Power Consumption	≤ 2VA
Output	
Type	Solid state
Maximum Load Current	1A steady state, 10A inrush at 60°C
Off State Leakage Current	≅ 5mA @ 230VAC
Voltage Drop	≅ 2.5V @ 1A
Protection	
Circuitry	Encapsulated
Dielectric Breakdown	≥ 2000V RMS terminals to mounting surface
Insulation Resistance	≥ 100 MΩ
Mechanical	
Mounting	Surface mount with one #10 (M5 x 0.8) screw
Dimensions	H 50.8 mm (2"); W 50.8 mm (2"); D 30.7 mm (1.21")
Termination	0.25 in. (6.35 mm) male quick connect terminals
Environmental	
Operating/Storage Temperature	-40° to 75°C / -40° to 85°C
Humidity	95% relative, non-condensing
Weight	≅ 2.4 oz (68 g)

TSDR SERIES



Wiring Diagram

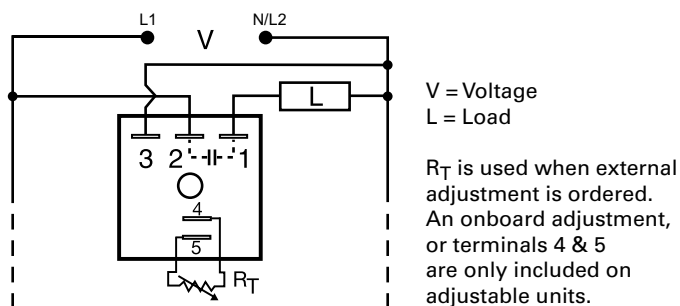

For dimensional drawing see: Appendix, page 512, Figure 16.

Description

The TSDR Series is an ON/OFF or OFF/ON recycling timing module designed to control metering pumps, chemical valves, flash lamps, or use in energy saving or duty cycling applications. The TSDR Series is designed for more demanding commercial and industrial applications where small size and accurate performance are required. The factory calibration for fixed time delays is $\pm 5\%$. The repeat accuracy, under stable conditions, is 0.5% of the time delay. The TSDR Series is rated to operate over an extended temperature range. Time delays of 0.1 seconds to 1000 minutes are available. The output is rated 1A steady and 10A inrush. The modules are totally solid state and encapsulated to protect the electronic circuitry.

Operation (Recycling - ON Time First)

Upon application of input voltage, the output energizes and the T1, ON time begins. At the end of the ON time, the output de-energizes and the T2, OFF time begins. At the end of the OFF time, the output energizes and the cycle repeats as long as input voltage is applied.

Reset: Removing input voltage resets the output and time delays, and returns the sequence to the T1 ON time.

Operation (Recycling - OFF Time First)

Upon application of input voltage, the T2 OFF time begins. At the end of the OFF time, the T1 ON time begins and the load energizes. At the end of the T1, T2 begins and the load de-energizes. This cycle repeats until input voltage is removed.

Reset: Removing input voltage resets the output and the sequence to T2 OFF time.

Features & Benefits

FEATURES	BENEFITS
Microcontroller based	Repeat accuracy +/- 0.5%, Factory calibration +/- 5%
1A steady, 10A inrush solid-state output	Provides 100 million operations in typical conditions
Totally solid state and encapsulated	No moving parts to arc and wear out over time and encapsulated to protect against shock, vibration, and humidity
Wide operating temperature range: -40° to 75°C	Reliable in demanding commercial and industrial applications
Compact, low cost design measuring 2 in. (50.8mm) square	Allows flexibility for OEM applications

Accessories



P1004-95, P1004-95-X Versa-Pot
Panel mountable, industrial potentiometer recommended for remote time delay adjustment.



P1023-6 Mounting bracket
The 90° orientation of mounting slots makes installation/removal of modules quick and easy.

Ordering Information

MODEL	INPUT VOLT.	ADJUST.	T1 ON TIME	FIRST DELAY	T2 OFF TIME
TSDR215SB18M	24VAC	Fixed	5s	Off time	18m
TSDR415SB18M	120VAC	Fixed	5s	Off time	18m
TSDR4412SA1	120VAC	On time fixed, off external	12s	On time	1 - 100s
TSDR442MA2	120VAC	On time fixed, off external	2m	On time	10 - 1000s
TSDR4430SA2	120VAC	On time fixed, off external	30s	On time	10 - 1000s
TSDR610.2SA0.2S	230VAC	Fixed	0.2s	On time	0.2s
TSDR6110SA30S	230VAC	Fixed	10s	On time	30s
TSDR612.5SA4.5S	230VAC	Fixed	2.5s	On time	4.5s
TSDR615SB18M	230VAC	Fixed	5s	Off time	18m
TSDR6412SA1	230VAC	On time fixed, off external	12s	On time	1 - 100s

If you don't find the part you need, call us for a custom product 800-843-8848

12 TIME DELAY RELAYS

TSDR SERIES

Accessories



P0700-7 Versa-Knob
Designed for 0.25 in (6.35 mm) shaft of Versa-Pot. Semi-gloss industrial black finish.



P1015-13 (AWG 10/12), **P1015-64** (AWG 14/16), **P1015-14** (AWG 18/22) **Female Quick Connect**
These 0.25 in. (6.35 mm) female terminals are constructed with an insulator barrel to provide strain relief.



P1015-18 Quick Connect to Screw Adapter
Screw adapter terminal designed for use with all modules with 0.25 in. (6.35 mm) male quick connect terminals.



C103PM (AL) DIN Rail
35 mm aluminum DIN rail available in a 36 in. (91.4 cm) length.



P1023-20 DIN Rail Adapter
Allows module to be mounted on a 35 mm DIN type rail with two #10 screws.

External Resistance vs. Time Delay

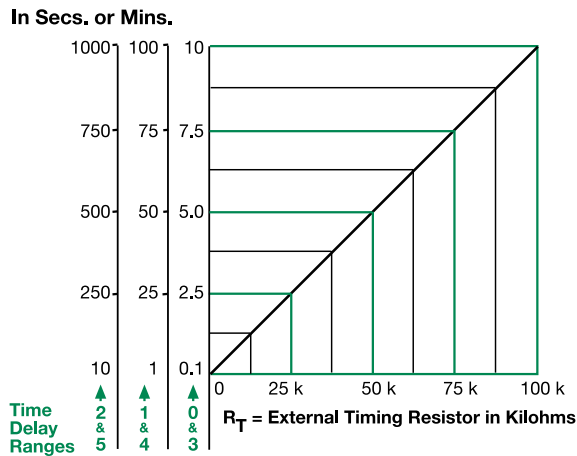

This chart applies to externally adjustable part numbers.
The time delay is adjustable over the time delay range selected by varying the resistance across the R_T terminals; as the resistance increases the time delay increases.
When selecting an external R_T , add the tolerances of the timer and the R_T for the full time range adjustment.
Examples: 1 to 50 S adjustable time delay, select time delay range 1 and a 50 K ohm R_T . For 1 to 100 S use a 100 K ohm R_T .

Function Diagrams

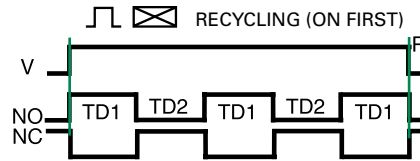

V = Voltage
NO = Normally Open Contact
NC = Normally Closed Contact
TD1, TD2 = Time Delay
R = Reset

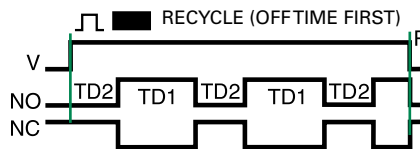

Specifications

Time Delay	
Range	0.1s - 1000ms in 6 adjustable ranges or fixed
Repeat Accuracy	±0.5% or 20ms, whichever is greater
Tolerance (Factory Calibration)	≤ ±5%
Reset Time	≤ 150ms
Time Delay vs Temp. & Voltage	≤ ±5%
Input	
Voltage	24, 120, or 230VAC
Tolerance	±20%
AC Line Frequency	50/60 Hz
Power Consumption	≤ 2VA
Output	
Type	Solid state
Maximum Load Current	1A steady state, 10A inrush at 60°C
Off State Leakage Current	≅ 5mA @ 230VAC
Voltage Drop	≅ 2.5V @ 1A
Protection	
Circuitry	Encapsulated
Dielectric Breakdown	≥ 2000V RMS terminals to mounting surface
Insulation Resistance	≥ 100 MΩ
Mechanical	
Mounting	Surface mount with one #10 (M5 x 0.8) screw
Dimensions	H 50.8 mm (2"); W 50.8 mm (2"); D 30.7 mm (1.21")
Termination	0.25 in. (6.35 mm) male quick connect terminals
Environmental	
Operating/Storage Temperature	-40° to 75°C / -40° to 85°C
Humidity	95% relative, non-condensing
Weight	≅ 2.4 oz (68 g)

PTHF4900DK

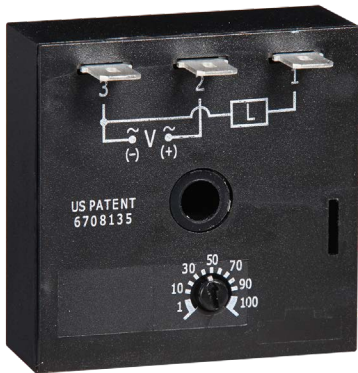

Description

The PTHF4900DK can be used for a variety of applications from chemical metering, to temperature regulating, to energy management. The infinite adjustability from 1 to 99% provides accurate percentage on control over a wide factory fixed cycle period. When mounted on a metal surface, it can be used to drive solenoids, contactors, relays, or lamps, up to 20A steady, 200A inrush. The PTHF4900DK is the suggested replacement for the PT Series.

Operation (Percentage)

Upon application of input voltage, the output energizes and the T1 ON time begins. At the end of the ON time, the output de-energizes and the T2 OFF time begins. At the end of the OFF time, the output energizes and the cycle repeats as long as input voltage is applied. Increasing the ON time decreases the OFF time. The total cycle period is equal to the ON time plus the OFF time. The total cycle period is factory fixed. ON time range is 1 to 99 percent of cycle period.

Reset: Removing input voltage resets the output and time delays, and returns the sequence to the T1 ON time.

Wiring Diagram

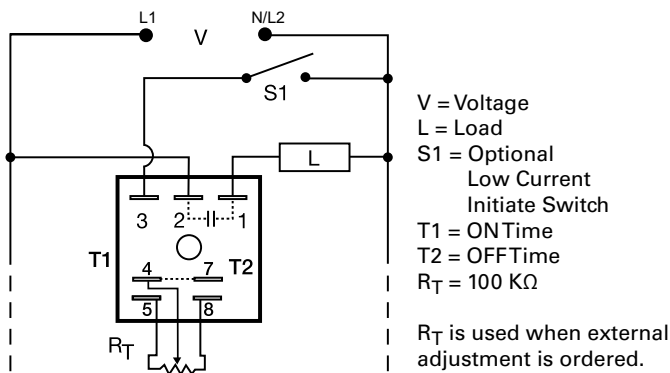

Features & Benefits

FEATURES	BENEFITS
Microcontroller based	Repeat accuracy +/- 0.5%, Factory calibration +/- 5%
ON/OFF recycling percentage control 1 to 99%	Accurate control over a wide factory fixed cycle period
Compact, low cost design	Allows flexibility for OEM applications and reduces component and labor costs
High load currents up to 20A, 200A inrush	Allows direct operation of motors, lamps, and heaters without a contactor
Totally solid state and encapsulated	No moving parts to arc and wear out over time and encapsulated to protect against shock, vibration, and humidity
Metalized mounting surface	Facilitates heat transfer in high current applications

Accessories



P1004-95, P1004-95-X Versa-Pot

Panel mountable, industrial potentiometer recommended for remote time delay adjustment.



P0700-7 Versa-Knob

Designed for 0.25 in (6.35 mm) shaft of Versa-Pot. Semi-gloss industrial black finish.



P1015-13 (AWG 10/12), P1015-64 (AWG 14/16) Female Quick Connect

These 0.25 in. (6.35 mm) female terminals are constructed with an insulator barrel to provide strain relief.



P1015-18 Quick Connect to Screw Adapter

Screw adapter terminal designed for use with all modules with 0.25 in. (6.35 mm) male quick connect terminals.

For dimensional drawing see: Appendix, page 512, Figure 19.

PTHF4900DK

Specifications

Time Delay

Type	External or onboard knob
Range/External	
Adjustment Resistance	Adjustable from 1 - 99% / $R_T = 100\text{ K}\Omega$
Cycle Period	Fixed from 10s - 1000m
Repeat Accuracy	$\pm 0.5\%$ or 20ms, whichever is greater
Cycle Period Tolerance	
(Factory Calibration)	$\leq \pm 5\%$
Reset Time	$\leq 150\text{ms}$
Time Delay vs Temp. & Voltage	$\leq \pm 10\%$

Input

Voltage	120 or 230VAC
Tolerance	$\pm 20\%$
AC Line Frequency	50/60 Hz
Power Consumption	$\leq 2\text{VA}$

Output

Type	Solid state	
Maximum Load Currents	Steady State	Inrush*
	1A	10A

Voltage Drop $\approx 2.5\text{V}$ at rated current

OFF State Leakage Current $\approx 5\text{mA}$ @ 230VAC

Protection

Circuitry	Encapsulated
Dielectric Breakdown	$\geq 2000\text{V RMS}$ terminals to mounting surface
Insulation Resistance	$\geq 100\text{ M}\Omega$

Mechanical

Mounting * Dimensions

Surface mount with one #10 (M5 x 0.8) screw
H 50.8 mm (2"); **W** 50.8 mm (2");
D 38.4 mm (1.51")
 0.25 in. (6.35 mm) male quick connect terminals

Termination Environmental Operating/Storage Temperature Humidity

-40° to 60°C / -40° to 85°C
 95% relative, non-condensing
 6, 10, 20A units: $\approx 3.9\text{ oz}$ (111 g)

*Units rated $\geq 6\text{A}$ must be bolted to a metal surface using the included heat sink compound. The maximum mounting surface temperature is 90°C. Inrush: Non-repetitive for 16ms.

Function Diagram

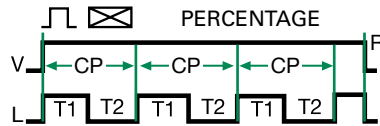

V = Input Voltage
 CP = Cycle Period
 L = Load
 T1 = ON Time
 T2 = OFF Time
 R = Reset

TDMB SERIES

Delay-on-Make/Delay-on-Break



8-PIN



11-PIN

Wiring Diagram

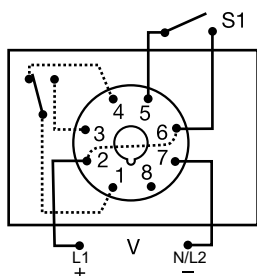

8-PIN OCTAL SPDT

V = Voltage
S1 = Initiate Switch or Thermostat

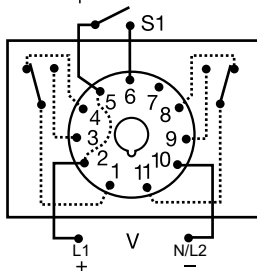

Relay contacts are isolated.

11-PIN DPDT
(P/N ends with D)

Description

The TDMB combines both delay-on-make and delay-on-break functions into one plug-in package. Selection of the time period is accomplished with dual switches, one for the on delay and the other for the off delay. SPDT or DPDT output options provide isolated, 10A switching capability.

Operation (Delay-on-Make/Delay-on-Break)

Input voltage must be applied at all times. The output relay is de-energized. Upon closure of the initiate switch, the green LED glows and the delay-on-make time delay (T1) begins. At the end of T1, the output relay energizes and the red LED glows. When the initiate switch opens, the green LED turns OFF and the delay-on-break time delay (T2) begins. At the end of T2, the output relay de-energizes and the red LED turns OFF.

Reset: Removing input voltage resets time delay and output. Opening the initiate switch during the delay-on-make delay, resets T1. Closing the initiate switch during the delay-on-break delay, resets T2.

Features & Benefits

FEATURES	BENEFITS
Digital circuitry	Repeat Accuracy +/- 0.1%, Setting accuracy +/- 2%
Isolated, 10A, SPDT or DPDT output contacts	Allows control of loads for AC or DC voltages
User selectable Delay-on-Make and Delay-on-Break time delay	Timing settings are independently adjustable for added flexibility
Industry standard octal plug connection	Eliminates need for special connectors
LED Indication	Provides visual indication of initiate, timing, and relay output status
DIP switch adjustment	Provides first time setting accuracy

Accessories



BZ1 Front Panel Mount Kit

Provides an easy method of through-the-panel mounting of 8- or 11-pin plug-in timers, flashers, and other controls.



NDS-8 Octal 8-pin Socket

8-pin 35mm DIN rail or surface mount. Surface mounted with two #6 screws or snaps onto a 35 mm DIN rail. Uses PSC8 hold-down clips.



NDS-11 11-pin Socket

11-pin 35mm DIN rail or surface mount. Surface mounted with two #6 screws or snaps onto a 35 mm DIN rail. Uses PSC11 hold-down clips.



PSC8 or PSC11 Hold-down Clips

Securely mounts plug-in controls in any position. Provides protection against vibration. Use PSC8 with NDS-8 Octal Socket or PSC11 with NDS-11 Socket. Sold in sets of two.

For dimensional drawing see: Appendix, page 512, Figure 23.

Ordering Information

MODEL	INPUT VOLTAGE	DELAY-ON-MAKE	DELAY-ON-BREAK	PLUG TYPE
TDMB411	120VAC	0.1 - 102.3s in 0.1s increments	0.1 - 102.3s in 0.1s increments	Octal (8-pin) SPDT
TDMB413D	120VAC	0.1 - 102.3s in 0.1s increments	10 - 10230s in 10s increments	11-pin DPDT
TDMB422	120VAC	1 - 1023s in 1s increments	1 - 1023s in 1s increments	Octal (8-pin) SPDT
TDMB422D	120VAC	1 - 1023s in 1s increments	1 - 1023s in 1s increments	11-pin DPDT
TDMB622	230VAC	1 - 1023s in 1s increments	1 - 1023s in 1s increments	Octal (8-pin) SPDT

If you don't find the part you need, call us for a custom product 800-843-8848

TDMB SERIES

Specifications

Time Delay

Type	Microcontroller circuitry
Range**	0.1 - 102.3s in 0.1s increments 1 - 1023s in 1s increments 10 - 10,230s in 10s increments
Repeat Accuracy	±0.1% or 20ms, whichever is greater
Setting Accuracy	≤ ±2% or 50ms, whichever is greater
Reset Time	≤ 150ms
Time Delay vs Temp. & Voltage	≤ ±2%
Control LED Indicator	Green; on when the initiate switch is closed
Input Voltage	12 or 24VDC; 24, 120, or 230VAC; 24 to 240VAC/DC; 12 to 48VDC

Tolerance	
12VDC & 24VDC/AC	-15% - 20%
110 to 230VAC/DC	-20% - 10%
AC Line Frequency/DC Ripple	50/60 Hz / ≤ 10%
Power Consumption	AC ≤ 2VA; DC ≤ 2W

Output Type	Electromechanical relay
Form	SPDT or DPDT
Rating	10A resistive @ 120/240VAC & 28VDC; 1/3 hp @ 230VAC
Life	Mechanical - 1 x 10 ⁷ ; Electrical - 1 x 10 ⁵
Max. Switching Voltage	250VAC
Relay LED Indicator	Red; on when output relay energizes (not included on 12VDC units)

Protection	
Insulation Resistance	≥ 100M
Polarity	DC units are reverse polarity protected
Isolation Voltage	≥ 1500V RMS input to output

Mechanical	
Mounting	Plug-in socket
Dimensions	H 81.3 mm (3.2"); W 60.7 mm (2.4"); D 45.2 mm (1.8")
Termination	Octal 8-pin plug-in, magnal 11-pin plug-in

Environmental	
Operating/Storage Temperature	-20° to 60°C / -30° to 85°C
Weight	≈ 6 oz (170 g)

** For CE approved applications, power must be removed from the unit when a switch position is changed.

Digi-Set Binary Switch Operation

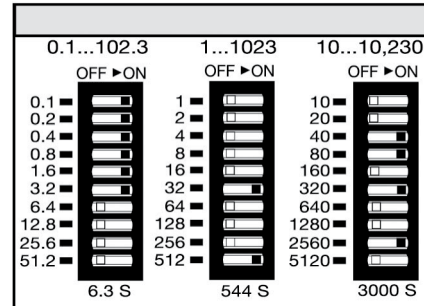

Function Diagram

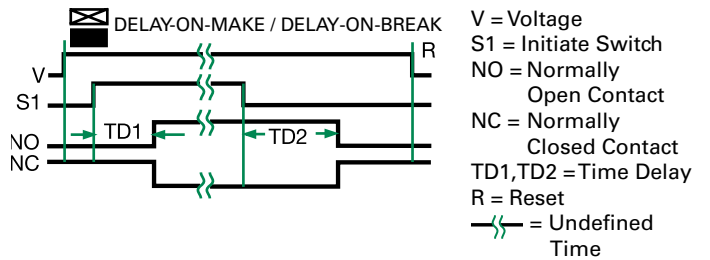

ESD52233

Delay-on-Make/Interval

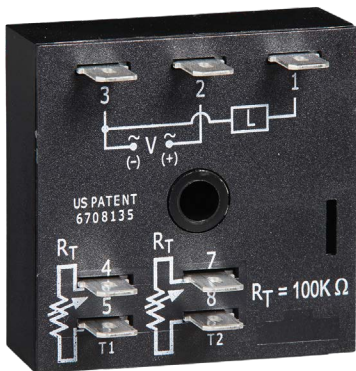

Description

The ESD5 Series is an accurate, solid-state, delayed interval timer. It offers a 1A steady, 10A inrush output and is available with adjustable or fixed time delays of 0.1 seconds to 1000 minutes in six ranges. Input voltages of 24, 120, or 230VAC are available. Encapsulation offers protection against shock and vibration. Adjustment options are factory fixed, onboard or externally adjustable. The repeat accuracy, under stable conditions, is 0.1%. The factory calibration of the time delay is $\pm 5\%$.

Operation (Delayed Interval)

Upon application of input voltage, the T1 delay-on-make time delay begins and the output remains de-energized. At the end of this delay, the output energizes and the T2 interval delay begins. At the end of the interval delay period, the output de-energizes.

Reset: Removing input voltage resets the output and the time delays, and returns the sequence to the first delay.

Wiring Diagram

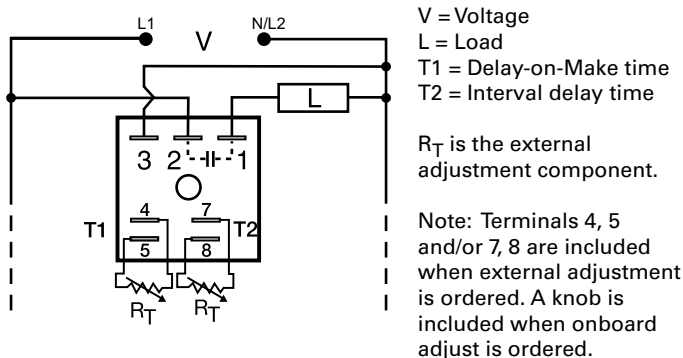

Features & Benefits

FEATURES	BENEFITS
Compact, low cost design measuring 2 in. (50.8mm) square	Allows flexibility for OEM applications and reduces component and labor costs
Microcontroller based	Repeat Accuracy + / - 0.1%, Factory calibration + / - 5%
1A steady, 10A inrush solid-state output	Provides 100 million operations in typical conditions.
Totally solid state and encapsulated	No moving parts to arc and wear out over time and encapsulated to protect against shock, vibration, and humidity

For dimensional drawing see: Appendix, page 512, Figure 16.

Accessories



P1004-95, P1004-95-X Versa-Pot
Panel mountable, industrial potentiometer recommended for remote time delay adjustment.



P1023-6 Mounting bracket
The 90° orientation of mounting slots makes installation/removal of modules quick and easy.



P0700-7 Versa-Knob
Designed for 0.25 in. (6.35 mm) shaft of Versa-Pot. Semi-gloss industrial black finish.



P1015-64 (AWG 14/16) Female Quick Connect
These 0.25 in. (6.35 mm) female terminals are constructed with an insulator barrel to provide strain relief.



P1015-18 Quick Connect to Screw Adapter
Screw adapter terminal designed for use with all modules with 0.25 in. (6.35 mm) male quick connect terminals.



C103PM (AL) DIN Rail
35 mm aluminum DIN rail available in a 36 in. (91.4 cm) length.

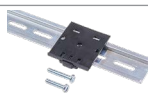

P1023-20 DIN Rail Adapter
Allows module to be mounted on a 35 mm DIN type rail with two #10 screws.

ESD52233

External Resistance vs. Time Delay

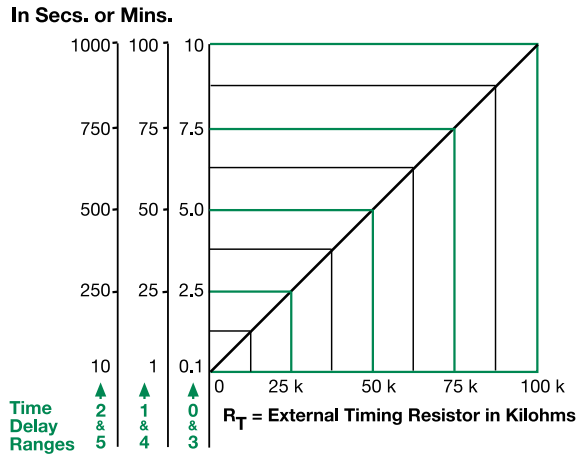

This chart applies to externally adjustable part numbers.
The time delay is adjustable over the time delay range selected by varying the resistance across the R_T terminals; as the resistance increases the time delay increases.
When selecting an external R_T , add the tolerances of the timer and the R_T for the full time range adjustment.
Examples: 1 to 50 S adjustable time delay, select time delay range 1 and a 50 K ohm R_T . For 1 to 100 S use a 100 K ohm R_T .

Function Diagram

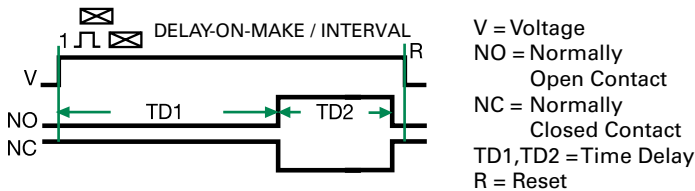

Specifications

Time Delay Range	0.1s - 1000m in 6 adjustable ranges or fixed
Repeat Accuracy (Factory Calibration)	±0.1% or 20ms, whichever is greater
Reset Time	≤ 150ms
Time Delay vs Temp. & Voltage	≤ ±2%
Input Voltage	24VAC
Tolerance	±20%
AC Line Frequency	50/60 Hz
Power Consumption	≤ 2VA
Output Type	Solid state
Rating	1A steady state, 10A inrush at 60°C
OFF State Leakage Current	≅ 5mA @ 230VAC
Voltage Drop	≅ 2.5V @ 1A
Protection	Encapsulated
Circuitry	≥ 2000V RMS terminals to mounting surface
Dielectric Breakdown	≥ 100 MΩ
Insulation Resistance	
Mechanical Mounting	Surface mount with one #10 (M5 x 0.8) screw
Dimensions	H 50.8 mm (2"); W 50.8 mm (2"); D 30.7 mm (1.21")
Termination	0.25 in. (6.35 mm) male quick connect terminals
Environmental	
Operating/Storage Temperature	-40° to 75°C / -40° to 85°C
Humidity	95% relative, non-condensing
Weight	≅ 2.4 oz (68g)

KRPD SERIES

Relay Output Timer



Wiring Diagram

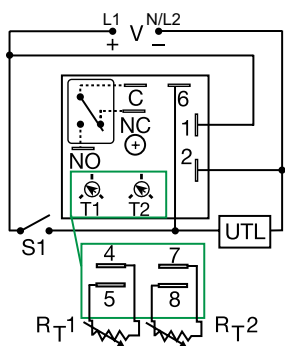

V = Voltage
C = Common, Transfer Contact
NC = Normally Closed
NO = Normally Open
S1 = Initiate Switch
UTL = Untimed Load

A knob is supplied for adjustable units or R_T terminals for external adjust. The untimed load is optional. S1 is not used for some functions.

For dimensional drawing see: Appendix, page 512, Figure 16.

Description

The KRPD Series is a factory programmed time delay relay available with 1 of 12 standard dual functions. The time delays can be factory fixed, onboard or externally adjustable or a combination of fixed and adjustable. The SPDT output relay contacts offer a full 10A rating with complete isolation. Its microcontroller timing circuit provides excellent repeat accuracy and stability. Encapsulation protects against shock, vibration, and humidity. The KRPD Series is a cost effective approach for OEM applications that require small size, isolation, accuracy and long life.

Features & Benefits

FEATURES	BENEFITS
Microcontroller based	Repeat Accuracy + / - 0.5%
Compact design	Allows flexibility for OEM applications
Isolated, 10A, SPDT output contacts	Allows control of loads for AC or DC voltages
Encapsulated	Encapsulated to protect against shock, vibration, and humidity

Accessories



P1004-95, P1004-95-X Versa-Pot
Panel mountable, industrial potentiometer recommended for remote time delay adjustment.



P0700-7 Versa-Knob
Designed for 0.25 in. (6.35 mm) shaft of Versa-Pot. Semi-gloss industrial black finish.



P1015-64 (AWG 14/16) Female Quick Connect
These 0.25 in. (6.35 mm) female terminals are constructed with an insulator barrel to provide strain relief.



P1015-18 Quick Connect to Screw Adapter
Screw adapter terminal designed for use with all modules with 0.25 in. (6.35 mm) male quick connect terminals.



C103PM (AL) DIN Rail
35 mm aluminum DIN rail available in a 36 in. (91.4 cm) length.



P1023-20 DIN Rail Adapter
Allows module to be mounted on a 35 mm DIN type rail with two #10 screws.

Ordering Information

MODEL	INPUT	ADJUSTMENT 1	TIME DELAY 1	ADJUSTMENT 2	TIME DELAY 2	FUNCTION
KRPD215S190SMB	24VAC	Fixed	5s	Fixed	90s	Delay-on-Make/Delay-on-Break
KRPD417M113MRXD	120VAC	Fixed	7m	Fixed	13m	Recycling/Off Time First
KRPDA175S130SMI	24 to 240VAC/DC	Fixed	75s	Fixed	30s	Delay-on-Make/Interval
KRPDA2129RXE	24 to 240VAC/DC	Onboard	0.1 - 10s	Onboard	10 - 1000h	Recycling
KRPDD2121MB	12 to 48VDC	Onboard	0.1-10s	Onboard	0.1-10s	Delay-on-Make/Delay-on-Break

If you don't find the part you need, call us for a custom product 800-843-8848

KRPD SERIES

Output Current/Ambient Temperature

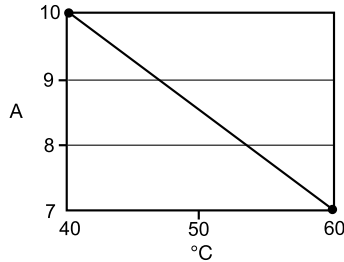

Function Diagrams

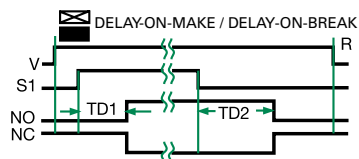

V = Voltage
S1 = Initiate Switch
NO = Normally Open Contact
NC = Normally Closed Contact
TD1, TD2 = Time Delay
R = Reset
—/— = Undefined Time

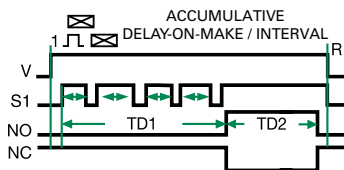
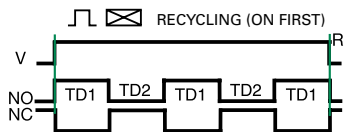
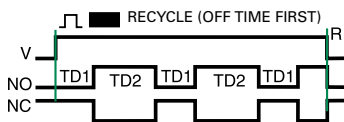
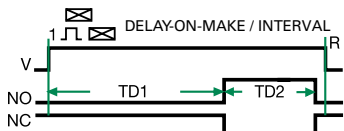

Specifications

Time Delay

Type Microcontroller circuitry
Range 0.1s - 1000h in 9 adjustable ranges or fixed (to 999)

Repeat Accuracy ±0.5% or 20ms, whichever is greater

Tolerance (Factory Calibration) ≤ ±2%

Reset Time ≤ 150ms

Initiate Time ≤ 40ms; 750 operations per minute

Time Delay vs. Temperature & Voltage ≤ ±2%

Input

Voltage 12 to 48VDC; 24 to 240VAC/DC

Tolerance -15% - 20%

12 to 48VDC -20% - 10%

24 to 240VAC/DC 50/60 Hz / ≤ 10%

AC Line Frequency/DC Ripple AC ≤ 2VA; DC ≤ 2W

Power Consumption

Output

Type Isolated relay contacts

Form SPDT

Rating (at 40°C) 10A resistive @ 125VAC

5A resistive @ 230VAC & 28VDC

1/4 hp @ 125VAC

250VAC

Mechanical - 1 x 10⁷; Electrical - 1 x 10⁵

Max. Switching Voltage

Life (Operations)

Protection Encapsulated

Circuitry ≥ 1500V RMS input to output

Isolation Voltage ≥ 100 MΩ

Insulation Resistance

Polarity DC units are reverse polarity protected

Mechanical

Mounting Surface mount with one #10 (M5 x 0.8) screw

Dimensions **H** 50.8 mm (2"); **W** 50.8 mm (2");

D 30.7 mm (1.21")

0.25 in. (6.35 mm) male quick connects

Termination

Environmental

Operating/Storage Temperature -40° to 60°C / -40° to 85°C

Humidity 95% relative, non-condensing

Weight ≈ 2.6 oz (74 g)

CT SERIES

Delay-on-Make/Delay-on-Break Timer



Description

The CT Series combines a delay-on-make and delay-on-break time delay into one unit and may be used to control fan delays in heating and/or cooling equipment. The CT includes bypass circuitry to allow it to operate with cooling anticipators ≥ 3000 ohms. It is designed to operate in 24VAC control circuits. Several CT modules may be combined to provide sequencing of any number of loads and sequencing off of the same loads, such as electric heating elements.

Operation (Delay-on-Make/Delay-on-Break)

Forced Air Heating or Air Conditioning (as shown): When the thermostat closes, the compressor relay is immediately energized. At the end of a fixed delay-on-make delay (T1), the fan relay is energized. When the thermostat opens, the compressor relay is de-energized and the delay-on-break delay is initiated. On completion of the fixed delay-on-break delay (T2) the fan relay is de-energized. If the thermostat is reclosed during the delay-on-break delay, the delay-on-break delay is reset and the fan relay remains energized. If the thermostat is closed when input voltage is applied, the delay-on-make delay (T1) begins as normal.

Reset: Removing input voltage resets the output and time delays.

Wiring Diagram

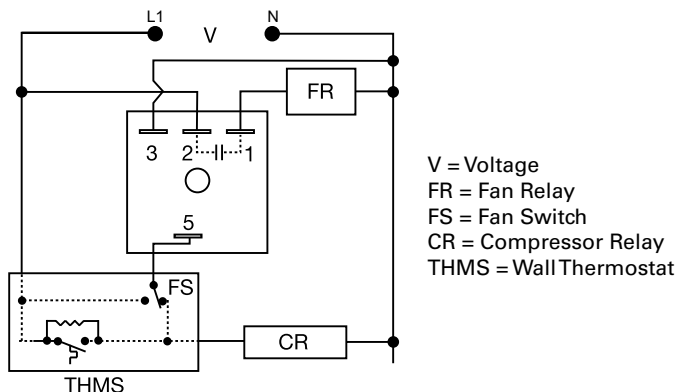

For dimensional drawing see: Appendix, page 512, Figure 16.

Features & Benefits

FEATURES	BENEFITS
Delay-on-Make and Delay-on-Break in one unit	Simplifies wiring and installation, and optimizes efficiency of heating and cooling systems
Totally solid state and encapsulated	No moving parts to arc and wear out over time and encapsulated to protect against shock, vibration, and humidity
Interconnectability with other CT modules	Combine modules to provide sequencing on of a number of loads and sequencing off of the same loads

Accessories



P1015-64 (AWG 14/16) Female Quick Connect

These 0.25 in. (6.35 mm) female terminals are constructed with an insulator barrel to provide strain relief.



P1023-6 Mounting bracket

The 90° orientation of mounting slots makes installation/removal of modules quick and easy.



P1015-18 Quick Connect to Screw Adapter

Screw adapter terminal designed for use with all modules with 0.25 in. (6.35 mm) male quick connect terminals.

Ordering Information

MODEL	DELAY-ON-MAKE (FIXED SECONDS)	DELAY-ON-BREAK (FIXED SECONDS)
CT1S30	1	30
CT1S45	1	45
CT1S8	1	8
CT1S90	1	90
CT30S1	30	1
CT45S45	45	45
CT5S300	5	300

If you don't find the part you need, call us for a custom product 800-843-8848

CT SERIES

Accessories



C103PM (AL) DIN Rail
35 mm aluminum DIN rail available in a 36 in. (91.4 cm) length.



P1023-20 DIN Rail Adapter
Allows module to be mounted on a 35 mm DIN type rail with two #10 screws.

Function Diagram

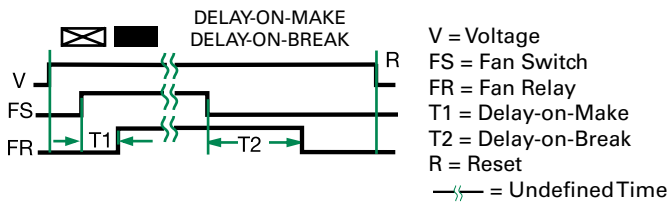

Specifications

Time Delay

Type Microcontroller

Range 1 - 600s

Repeat Accuracy ±5%

Tolerance ±20%

(Factory Calibration) ≤ 300ms

Recycle Time ≤ 300ms

Input 24VAC

Voltage ±15%

Tolerance 50/60 Hz

AC Line Frequency 50/60 Hz

Output Solid state

Type NO

Form 0.75A steady state, 5A inrush at 55°C

Rating ≈ 1.25V

Voltage Drop ≈ 1.25V

Protection Encapsulated

Circuitry ≥ 2000V rms terminals to mounting surface

Dielectric Breakdown ≥ 100 MΩ

Insulation Resistance ≥ 100 MΩ

Mechanical Surface mount with one #10 (M5 x 0.8) screw

Mounting **H** 50.8 mm (2"); **W** 50.8 mm (2");

Dimensions **D** 30.7 mm (1.21")

Termination 0.25 in. (6.35 mm) male quick connect terminals

Termination 0.25 in. (6.35 mm) male quick connect terminals

Environmental Operating/Storage

Operating/Storage Temperature -40° to 70°C / -40° to 85°C

Temperature Humidity 95% relative, non-condensing

Humidity Weight ≈ 2.4 oz (68 g)

Weight Thermostat Anticipator Resistor: ≥ 3000 Ω

Thermostat Anticipator Resistor: ≥ 3000 Ω

T2D120A15M

Lockout



Wiring Diagram

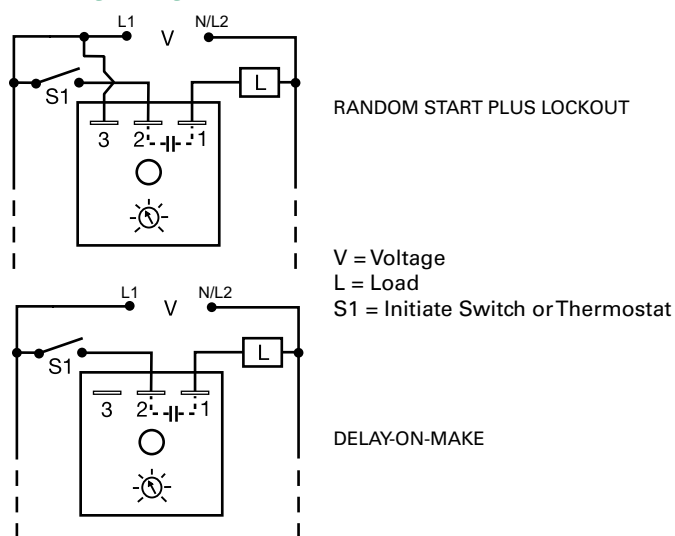

Description

The T2D provides protection against short cycling of compressors and other motors. At the end of each operation, a lockout delay prevents restarting the compressor or motor until the delay is completed. 24VAC models can be used with thermostats that include a cooling anticipator resistor. It can be connected in series with the load for delay-on-make operation.

Operation (Lockout with Random Start)

Connection #1: Upon application of input voltage, a random start time delay begins. At the end of this time delay, the output is energized.

Lockout Delay: Input voltage must be applied prior to and during timing. When the thermostat or initiate switch opens, the output de-energizes and the lockout time delay begins. At the end of the lockout delay, the output is energized allowing the load to immediately energize when the initiate switch or thermostat closes.

Connection #2: Upon application of input voltage and closure of initiate switch, the time delay begins. At the end of the time delay, the output is energized and remains energized until power is removed.

Reset: Removing power resets the output and the time delay.

Features & Benefits

FEATURES	BENEFITS
Lockout delay	Prevents rapid cycling of compressor
Random start delay	Prevents low voltage starting
Analog circuitry	Repeat Accuracy +/- 1%
Compact design	Allows flexibility for OEM applications
1A steady, 10A inrush output	Provides 100 million operations in typical conditions.
Totally solid state and fully encapsulated	No moving parts to arc and wear out over time and encapsulated to protect against shock, vibration and humidity

For dimensional drawing see: Appendix, page 512, Figure 16.

Accessories



P1023-6 Mounting bracket
The 90° orientation of mounting slots makes installation/removal of modules quick and easy.



P1015-64 (AWG 14/16) Female Quick Connect
These 0.25 in. (6.35 mm) female terminals are constructed with an insulator barrel to provide strain relief.



P1015-18 Quick Connect to Screw Adapter
Screw adapter terminal designed for use with all modules with 0.25 in. (6.35 mm) male quick connect terminals.



C103PM (AL) DIN Rail
35 mm aluminum DIN rail available in a 36 in. (91.4 cm) length.

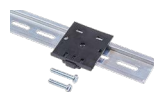

P1023-20 DIN Rail Adapter
Allows module to be mounted on a 35 mm DIN type rail with two #10 screws.

T2D120A15M

Specifications

Input

Voltage 120/230VAC in 2 ranges
Tolerance ±20%

AC Line Frequency 50/60 Hz

Output

Minimum Load Current 24VAC - 100mA; 120/230VAC - 40mA

Rating 1A steady state, 10A inrush at 60°C

Voltage Drop ≈ 2.5V @ 1A

Time Delay

Initiate Time After timing - 16ms

Type Analog circuitry

Lockout & Random

Start Delays 1s - 100m in 4 adjustable ranges or fixed
Note: The lockout & random start delays are the same length.

Tolerance Adjustable: ±30%; factory fixed: ±30%

Repeat Accuracy ±1% or 20ms, whichever is greater

Reset Time After timing - ≤ 16ms;

During timing - ≤ 200ms

Protection

Dielectric Breakdown ≥ 2000V RMS terminals to mounting surface

Insulation Resistance ≥ 100 MΩ

Mechanical

Mounting Surface mount with one #10 (M5 x 0.8) screw

Dimensions **H** 50.8 mm (2"); **W** 50.8 mm (2");

D 30.7 mm (1.21")

Termination 0.25 in. (6.35 mm) male quick connect terminals

Environmental

Operating/Storage

Temperature -20° to 60°C / -40° to 85°C

Humidity 95% relative, non-condensing

Weight ≈ 2.4 oz (68 g)

Cooling Anticipator

(24VAC Units Only)

Minimum Cooling Anticipator ≥ 3,000 Ω

Function Diagram

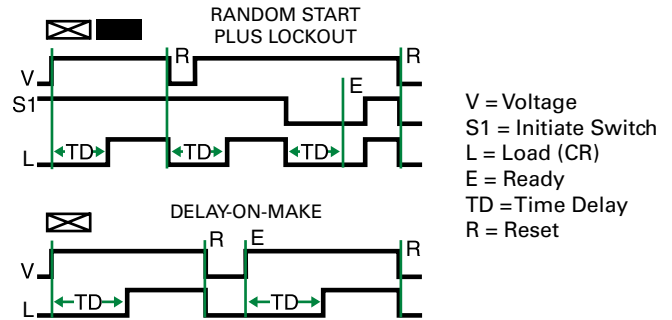

TA SERIES

Lockout



Wiring Diagram

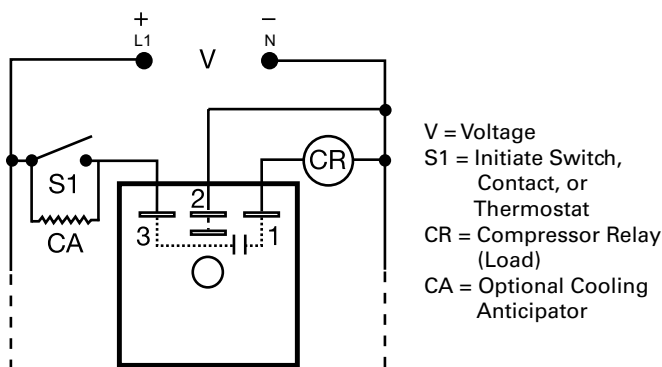

For dimensional drawing see: Appendix, page 512, Figure 16.

Description

The TA Series prevents rapid recycling of a compressor. A lockout delay is started when the thermostat opens, or input voltage is lost. Eliminates tripped circuit breakers or blown fuses caused by a locked rotor during short cycling. The TA will not allow the compressor to start when the line voltage is low. Chatter of the compressor relay is eliminated. Because of the fast initiate time, bounce of the thermostat will not be transmitted to the compressor relay coil. A 30 second delay provides anti-reversing protection for scroll compressors.

Operation (Lockout)

On initial closure of the S1, the compressor relay energizes immediately. When S1 opens or input voltage is interrupted, a lockout time delay is initiated. During this lockout time delay, the compressor relay cannot be energized. The low voltage (brownout) protection prevents energization of the compressor when the line voltage is low.

Reset: The lockout time delay cannot be reset. After the time delay is completed, the unit automatically resets.

Features & Benefits

FEATURES	BENEFITS
Lockout delay	Prevents rapid cycling of compressor and eliminates nuisance service calls due to blown fuse or tripped breaker by locked rotor during short cycling
Anti-reversing protection for scroll compressors	Extends life of equipment
Brownout protection	Timer will not allow the compressor to start during low line voltage conditions
Encapsulated	Protects against shock, vibration, and humidity
1A solid state output	No moving parts to arc and wear out. Provides up to 100 million operations under typical conditions

Accessories



P1023-6 Mounting bracket

The 90° orientation of mounting slots makes installation/removal of modules quick and easy.



P1015-64 (AWG 14/16) Female Quick Connect

These 0.25 in. (6.35 mm) female terminals are constructed with an insulator barrel to provide strain relief.



P1015-18 Quick Connect to Screw Adapter

Screw adapter terminal designed for use with all modules with 0.25 in. (6.35 mm) male quick connect terminals.



C103PM (AL) DIN Rail

35 mm aluminum DIN rail available in a 36 in. (91.4 cm) length.



P1023-20 DIN Rail Adapter

Allows module to be mounted on a 35 mm DIN type rail with two #10 screws.

Ordering Information

MODEL	INPUT VOLTAGE	TIME DELAY
TA12D1	12VDC	1m
TA12D2	12VDC	2m
TA24A0.5	24VAC	30s
TA24A3	24VAC	3m
TA24A5	24VAC	5m

If you don't find the part you need, call us for a custom product 800-843-8848

TA SERIES

Specifications

Input	
Voltage	12 or 24VDC; 24VAC
AC Line Frequency	50/60 Hz
Impedance	450 Ω (anticipator by-pass)
Output	
Minimum Load Current	75mA
Maximum Load Current	1A at 60°C
Voltage Drop	≤ 1.25V
Time Delay	≈ 16ms
Initiate Time	≈ 16ms
Lockout Time	Fixed 0.5, 1, 2, 3, or 5m
Tolerance	-15% - 35%
Protection	
Circuitry	Encapsulated
Low Voltage Protection	≈ 20V: 24VAC/DC; ≈ 9V: 12VDC
Dielectric Breakdown	≥ 2000V RMS terminals to mounting surface
Insulation Resistance	≥ 100 MΩ

Mechanical

Mounting	Surface mount with one #10 (M5 x 0.8) screw
Dimensions	H 50.8 mm (2"); W 50.8 mm (2"); D 30.7 mm (1.21")
Termination	0.25 in. (6.35 mm) male quick connect terminals
Environmental	
Operating/Storage Temperature	-40° to 70°C / -40° to 85°C
Humidity	95% relative, non-condensing
Weight	≈ 2.4 oz (68 g)
Thermostat	
Cooling Anticipator Resistor	≥ 1800 Ω

Function Diagram

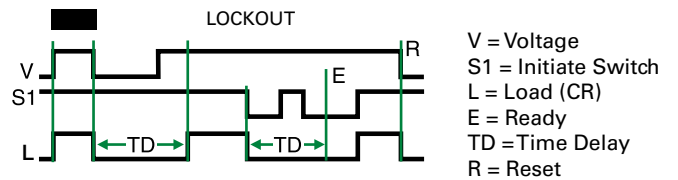

TAC1 SERIES

Delay-on-Make



Description

The TAC1 Series was designed to delay the operation of a compressor relay. It eliminates the possibility of relay chatter due to half-wave failure of the output. It connects in series with the load relay coil and provides a delay-on-make time delay each time input voltage is applied. It can be used for random start, anti-short cycling, sequencing, and many other applications. It is an excellent choice for all air conditioning and refrigeration equipment.

Operation (Delay-on-Make)

Upon application of input voltage, the time delay begins. The output is de-energized before and during the time delay. At the end of the time delay, the output energizes and remains energized until input voltage is removed.

Reset: Removing input voltage resets the time delay and output.

Features & Benefits

FEATURES	BENEFITS
Analog circuitry	Repeat accuracy +/- 2%, Factory calibration +/- 20%
0.5A steady state, 10A inrush	Provides 100 million operations in typical conditions.
Connects in series with load relay coil	Fail-safe design eliminates contactor chatter
Meets UL 873	UL Recognized for air conditioning and refrigeration equipment
Fully encapsulated	Protects against shock, vibration and humidity

Wiring Diagram

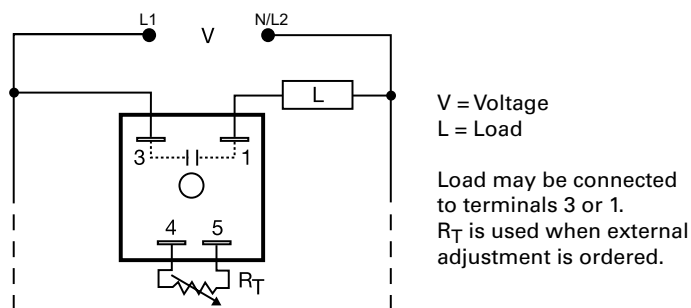

For dimensional drawing see: Appendix, page 512, Figure 16.

Accessories



P1004-XX, P1004-XX-X Versa-Pot
Panel mountable, industrial potentiometer recommended for remote time delay adjustment.



P1023-6 Mounting bracket
The 90° orientation of mounting slots makes installation/removal of modules quick and easy.



P0700-7 Versa-Knob
Designed for 0.25 in. (6.35 mm) shaft of Versa-Pot. Semi-gloss industrial black finish.



P1015-64 (AWG 14/16) Female Quick Connect
These 0.25 in. (6.35 mm) female terminals are constructed with an insulator barrel to provide strain relief.



P1015-18 Quick Connect to Screw Adapter
Screw adapter terminal designed for use with all modules with 0.25 in. (6.35 mm) male quick connect terminals.

Ordering Information

MODEL	INPUT VOLTAGE	ADJUSTMENT	TIME DELAY
TAC1223	24VAC	External	2 - 180s
TAC1411	120VAC	Fixed	1s
TAC1412	120VAC	Fixed	2s
TAC1413	120VAC	Fixed	3s
TAC14164	120VAC	Fixed	64s

If you don't find the part you need, call us for a custom product 800-843-8848

TAC1 SERIES

Accessories



C103PM (AL) DIN Rail
35 mm aluminum DIN rail available in a 36 in. (91.4 cm) length.



P1023-20 DIN Rail Adapter
Allows module to be mounted on a 35 mm DIN type rail with two #10 screws.



VTP(X)(X) Plug-on Adjustment Module
Mounts on modules with in-line adjustment terminals. Rated at 0.25W at 55°C. Available in resistance values from 5KΩ to 5MΩ.

Selection Table for VTP Plug-on Adjustment Accessory

Time Delay	VTP P/N
1 - 0.05-3s	VTP4B
2 - 0.5-60s	VTP4F
3 - 2-180s	VTP4J
4 - 5-600s	VTP5N

Selection Guide

R _T Selection Chart				
Desired Time Delay*				R _T
Seconds				
1	2	3	4	Megohm
0.05	0.5	2	5	0.0
0.5	10	30	60	0.5
1.0	20	60	120	1.0
1.5	30	90	180	1.5
2.0	40	120	240	2.0
2.5	50	150	300	2.5
3.0	60	180	360	3.0
			420	3.5
			480	4.0
			540	4.5
			600	5.0

* When selecting an external R_T add at least 30% for tolerance of unit and the R_T.

Function Diagram

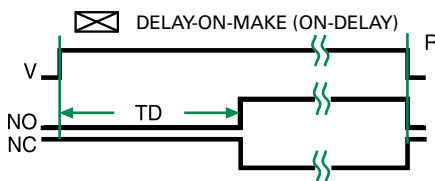

V = Voltage
NO = Normally Open Contact
NC = Normally Closed Contact
TD = Time Delay
R = Reset
—||— = Undefined Time

Specifications

Time Delay

Type Analog circuitry
Range 0.05 - 600s in 4 adjustable ranges or fixed
Repeat Accuracy ±2%

Tolerance (Factory Calibration) ±20%
Recycle Time ≤ 20ms after timing, during timing - 0.1% of time delay or 75ms, whichever is greater

Time Delay vs Temp. & Voltage

≤ ±10%

Input

Voltage 24, 120, or 230VAC
Tolerance ±20%
AC Line Frequency 50/60 Hz

Output

Type Solid state
Form NO, open during timing
Rating 0.5A steady state, 10A inrush at 60°C
Voltage Drop 120 & 230VAC: ≈ 4.2V @ 0.5A
24VAC: ≈ 2.5V @ 0.5A

Protection

Circuitry Encapsulated
Dielectric Breakdown ≥ 2000V RMS terminals to mounting surface
Insulation Resistance ≥ 100 MΩ

Mechanical

Mounting Surface mount with one #10 (M5 x 0.8) screw
Dimensions **H** 50.8 mm (2"); **W** 50.8 mm (2");
D 30.7 mm (1.21")
Termination 0.25 in. (6.35 mm) male quick connect terminals

Environmental

Operating/Storage Temperature

-40° to 80°C / -40° to 85°C

Humidity

95% relative, non-condensing

Weight

≈ 2.4 oz (68 g)

TL SERIES

Lockout



Wiring Diagram

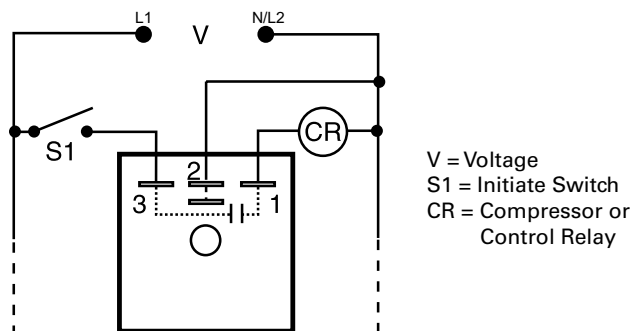

For dimensional drawing see: Appendix, page 512, Figure 16.

Description

The TL Series provides protection against short cycling of a compressor. At the end of each operation, or whenever power is lost, a lockout delay is initiated. This lockout delay prevents restarting of the compressor until the head pressure has equalized. Compressor relay chatter due to thermostat bounce is eliminated by use of optional one second delay-on-make. The TL Series should not be used with cooling anticipator resistors or solid-state switches. (See the TA Series).

Operation (Lockout)

Lockout: On initial closure of S1, the compressor relay energizes immediately (or after an optional 1s delay). When the S1 opens or input voltage is interrupted, the output opens and remains open for the lockout time delay. During this lockout time delay period, the compressor relay cannot be re-energized.

Reset: The lockout time delay cannot be reset. After the time delay is completed, the unit automatically resets.

Features & Benefits

FEATURES	BENEFITS
Lockout delay	Prevents rapid cycling of compressor and eliminates nuisance service calls due to blown fuse or tripped breaker by locked rotor during short cycling.
One second Delay-on-Make (models ending in T)	Eliminates contactor chatter due to thermostat bounce
Totally solid state and encapsulated	No moving parts to arc and wear out over time and encapsulated to protect against shock, vibration, and humidity
1A steady, 10A inrush, solid state output	Provides 100 million operations in typical conditions

Accessories



P1023-6 Mounting bracket

The 90° orientation of mounting slots makes installation/removal of modules quick and easy.



P1015-64 (AWG 14/16) Female Quick Connect

These 0.25 in. (6.35 mm) female terminals are constructed with an insulator barrel to provide strain relief.



P1015-18 Quick Connect to Screw Adapter

Screw adapter terminal designed for use with all modules with 0.25 in. (6.35 mm) male quick connect terminals.



C103PM (AL) DIN Rail

35 mm aluminum DIN rail available in a 36 in. (91.4 cm) length.



P1023-20 DIN Rail Adapter

Allows module to be mounted on a 35 mm DIN type rail with two #10 screws.

Ordering Information

MODEL	INPUT VOLTAGE	LOCKOUT TIME	DELAY-ON-MAKE
TL120A5T	120VAC	5m	1s
TL230A5	230VAC	5m	No delay
TL24A5T	24VAC	5m	1s

If you don't find the part you need, call us for a custom product 800-843-8848

TL SERIES

Specifications

Input

Voltage 24, 120, or 230VAC

AC Line Frequency 50/60 Hz

Tolerance ±20%

Output

Minimum Load Current ≤ 40mA

Maximum Load Current 1A @ 24VAC; 0.5A @ 120 & 230VAC at 60°C

Inrush Current 10A at 60°C

Voltage Drop 24VAC - 2.5V @ 1A

120 & 230VAC - 4.2V @ 0.5A

Time Delay

Initiate Time ≈ 8ms

Lockout Time* Fixed 2, 3, or 5m

Tolerance -15% - 35%

Option 1s delay-on-make eliminates contactor chatter due to thermostat bounce

Protection

Circuitry Encapsulated

Dielectric Breakdown ≥ 2000V RMS terminals to mounting surface

Insulation Resistance ≥ 100 MΩ

Mechanical

Mounting

Surface mount with one #10 (M5 x 0.8) screw

Dimensions

H 50.8 mm (2"); **W** 50.8 mm (2");

D 30.7 mm (1.21")

Termination

0.25 in. (6.35 mm) male quick connect terminals

Environmental

Operating/Storage

Temperature

-40° to 70°C / -40° to 85°C

Humidity

95% relative, non-condensing

Weight

≈ 2.4 oz (68 g)

*Power must be applied for at least 15 s to achieve a full lockout delay. Less than 15 s will result in proportionally shorter delay periods.

NOTE: Cooling anticipator resistor or leakage may cause erratic operation. See TA Series for use with 24VAC systems that include anticipator resistors or use solid-state switches.

Function Diagram

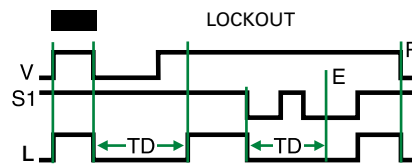

V = Voltage
S1 = Initiate Switch
L = Load (CR)
E = Ready
TD = Time Delay
R = Reset

TSA141300

Anti-Short Cycle, Solid State Timer



Wiring Diagram

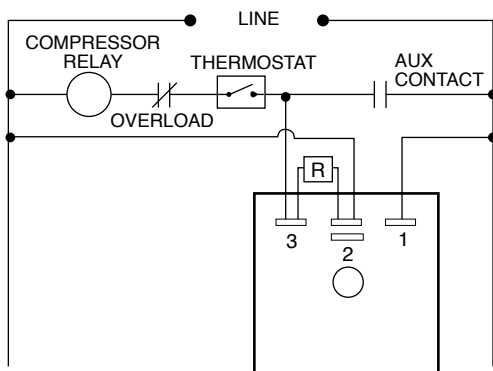

For dimensional drawing see: Appendix, page 512, Figure 16.

Description

The TSA141300 utilizes unique circuitry to provide random start and lockout delay in one small, rugged, inexpensive package. When connected as shown, the TSA141300 in a multiple unit situation, prevents all units from starting at one time with its random start feature. The TSA141300 also prevents the compressor from recycling rapidly which could result in a lock rotor condition. This lockout delay is initiated at the end of each operation of the compressor. A momentary loss of power would also initiate the lockout delay.

Operation

Random Start: With the thermostat closed, when line voltage is applied to system, a time delay is initiated. At the end of this delay, the compressor relay will be energized. (Random Start delay is equal to lockout delay.)

Anti-Short Cycle: At the end of each cycle, when the thermostat opens, a lockout delay is initiated which prevents re-energization of the compressor relay during this period. If the thermostat is closed after the time delay is completed, the compressor relay will energize immediately.

Loss of Power: If there is a momentary loss of power, the lockout will again be initiated preventing the compressor relay from energizing for the duration of the delay.

Features & Benefits

- Lockout Delay—prevents rapid recycling of compressor in air conditioning, refrigeration, and heat pump equipment
- Random Start Delay—provides staggered start up of multiple units
- Fast response time
- All Solid State with Encapsulated Circuitry

Specifications

Time Delay

Type	Factory fixed 5 minutes
Repeat Accuracy	± 5% under fixed conditions
Tolerance	Factory calibration: ± 15%
Time Delay vs. Temperature	± 10% max.
Input	
Voltage	120 volts AC
Tolerance	± 20% of nominal
AC Line Frequency	50/60 Hz
Output	
Type	Solid State
Maximum Load Current	1 ampere steady state, 10 amperes inrush at 60°C
Voltage Drop	2.5 volts typical at 1 ampere
Protection	
Transient	Protected
Dielectric Breakdown	Greater than 1500 volts RMS
Insulation Resistance	100 megohms min.

Mechanical

Mounting	Surface mount with one #8 or #10 screw
Package	Molded housing with encapsulated circuitry
Termination	0.25 in. (6.35 mm) male quick connect terminals
Dimensions	H 50.80 mm (2.0"); W 50.80 mm (2.0"); D 30.70 mm (1.21")

Environmental

Operating/Storage Temperature	-40°C to +80°C/-40°C to +85°C
Humidity	95% relative, non-condensing

Function Diagram

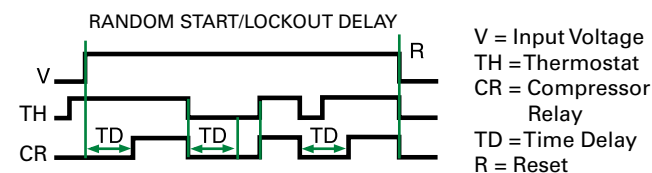

12 TIME DELAY RELAYS

HRV SERIES

Coin Counter



Wiring Diagram

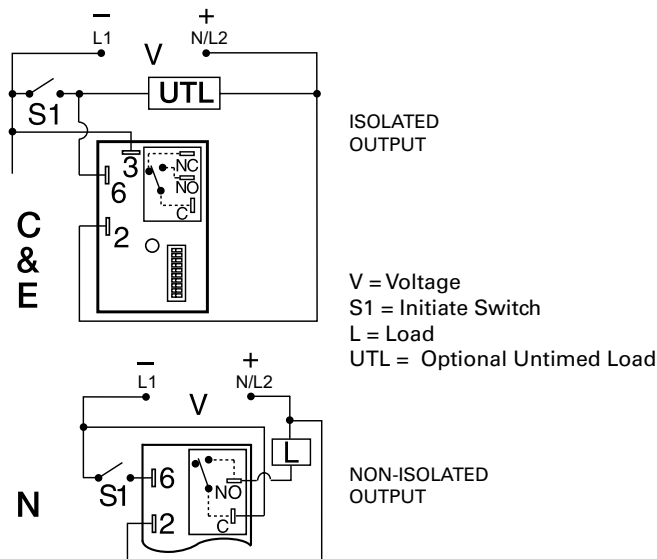

For dimensional drawing see: Appendix, page 512, Figure 17.

Ordering Information

MODEL	INPUT VOLTAGE	VEND TIME	MODE OF OPERATION	OUTPUT FORM & RATING
HRV11SC	12VDC	1 - 127s	Coin totalizer	30A SPDT, NO (isolated)
HRV24AC	24VAC	0.25 - 31.75m	Accumulating	30A SPDT, NO (isolated)
HRV41AE	120VAC	1 - 127s	Accumulating	30A SPDT, NO (isolated)
HRV41SE	120VAC	1 - 127s	Coin totalizer	30A SPDT, NO (isolated)
HRV42SE	120VAC	5 - 635s	Coin totalizer	30A SPDT, NO (isolated)
HRV43AE	120VAC	0.1 - 12.7m	Accumulating	30A SPDT, NO (isolated)
HRV43AN	120VAC	0.1 - 12.7m	Accumulating	30A SPDT, NO (non-isolated)
HRV43SE	120VAC	0.1 - 12.7m	Coin totalizer	30A SPDT, NO (isolated)

If you don't find the part you need, call us for a custom product 800-843-8848

Description

The HRV combines the accuracy of microcontroller based circuitry with an electromechanical relay output. The HRV's switching capacity allows direct control of loads like compressors, pumps, motors, heaters, and lighting. The HRV "S" version provides a vend time after the selected number of initiate switch closures to start is reached. The HRV "A" version includes all of the "S" features and allows the total vend time to be extended for each additional initiate switch closure. The HRV is ideal for cost sensitive single coin or token vending machines. The electronic circuitry is encapsulated to protect against humidity and vibration.

Operation

Coin Totalizer & Vending Timer ("S" Version):

Input voltage must be applied prior to & during operation. When the total number of S1 initiate switch closures equals the number to start set on the lower 3 DIP switches, the load energizes and the vending time set on the upper 7 DIP switches begins. At the end of the vending time, the load de-energizes and the vending time is reset. Closing the initiate switch during vend timing will have no effect on vend time delay.

Accumulating Vending Timer ("A" Version):

Input voltage must be applied prior to and during operation. When the total number of S1 initiate switch closures equals the number to start set on the lower 3 DIP switches, the load energizes and the vending time starts. For every initiate switch closure, the HRV unit adds one time per coin period, as set on the upper 7 DIP switches, to the total vending time.

Operation Note: If S1 is closed when input voltage is applied, the output remains de-energized and the S1 counter remains at zero closures. At least one "vend time" and one "closures to start" DIP switch must be in the "ON" position for proper operation.

Reset: Removing input voltage resets the vend time delay, the S1 closure counter, and de-energizes the output relay.

Features & Benefits

FEATURES	BENEFITS
Microcontroller based	Repeat accuracy +/- 0.1%, Setting accuracy 0 - 2%, or 50ms
Encapsulated	Protects against shock, vibration, and humidity
30A, 1Hp at 125VAC, normally open contacts	Allows direct control of loads like compressors, pumps, motors, and heaters without a contactor
Switch selectable coin start	Allows user flexibility to select the number of coins to start vending cycle
Coin switch can be connected to a counter	Provides user with accurate count of total number of coins collected

HRV SERIES

Accessories



P1023-6 Mounting bracket
The 90° orientation of mounting slots makes installation/removal of modules quick and easy.



P1015-13 (AWG 10/12), P1015-64 (AWG 14/16) Female Quick Connect
These 0.25 in. (6.35 mm) female terminals are constructed with an insulator barrel to provide strain relief.



P1015-18 Quick Connect to Screw Adapter
Screw adapter terminal designed for use with all modules with 0.25 in. (6.35 mm) male quick connect terminals.



C103PM (AL) DIN Rail
35 mm aluminum DIN rail available in a 36 in. (91.4 cm) length.



P1023-20 DIN Rail Adapter
Allows module to be mounted on a 35 mm DIN type rail with two #10 screws.

Switch Adjustment

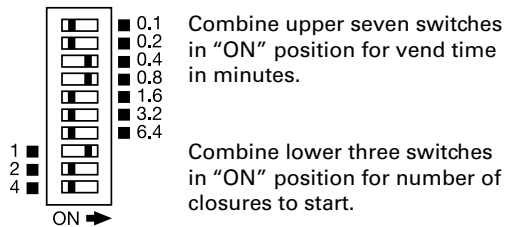

Function Diagram

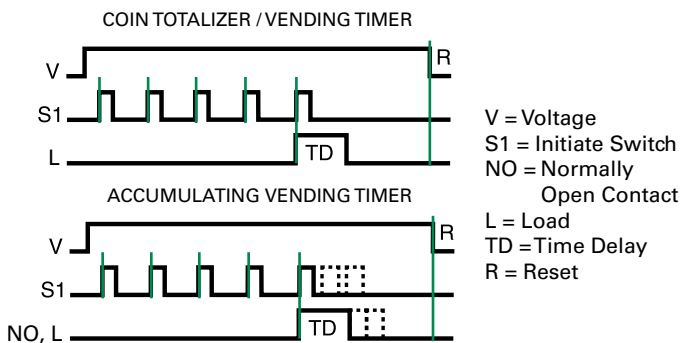

Specifications

Count Functions/ Switch Type	Mechanical (counts on switch closure)
Minimum Switch Closure Time	≥ 20ms
Minimum Switch Open (between closures) Time	≥ 20ms
Count Range to Start	1 - 7 counts
Maximum Counts ("A" Version)	250
Time Delay/Range ***	Adjustable 1s - 31.75m in 4 ranges
Adjustment	7 of a 10 position DIP switch
Setting Accuracy	0% to +2% or 50ms, whichever is greater
Repeat Accuracy	±0.1% or 20ms, whichever is greater
Reset Time	≤ 150ms
Time Delay vs Temp. & Voltage	≤ ±2%
Input Voltage	12 or 24VDC; 24, 120, or 230VAC
Tolerance	
12VDC & 24VDC/AC	-15% - 20%
120 & 230 VAC	-20% - 10%
AC Line Frequency/DC Ripple	50/60 Hz / ≤ 10%
Power Consumption	AC ≤ 4VA; DC ≤ 2W
Output Type	Electromechanical relay
Form	Isolated, SPDT or non-isolated, SPDT
Ratings	SPDT-NO SPDT-NC
General Purpose	
125/240VAC	30A 15A
Resistive	
125/240VAC	30A 15A
28VDC	20A 10A
Motor Load	
125VAC	1 hp* 1/4 hp**
240VAC	2 hp** 1 hp**
Life	Mechanical - 1 x 10 ⁶ ; Electrical - 1 x 10 ⁵ , *3 x 10 ⁴ , ** 6,000
Protection	
Surge	IEEE C62.41-1991 Level A
Circuitry	Encapsulated
Dielectric Breakdown	≥ 1500V RMS input to output on isolated units
Insulation Resistance	≥ 100 MΩ
Mechanical	
Mounting	Surface mount with one #10 (M5 x 0.8) screw
Dimensions	H 76.7 mm (3"); W 50.8 mm (2"); D 38.1 mm (1.5")
	0.25 in. (6.35 mm) male quick connect terminals
Termination	
Environmental	
Operating/Storage	
Temperature	-40° to 70°C / -40° to 85°C
Humidity	95% relative, non-condensing
Weight	≈ 3.9 oz (111 g)

***For CE approved applications, voltage must be removed when a switch position is changed.

12 TIME DELAY RELAYS