

REVISION		DESCRIPTION
REV	DATE	DESCRIPTION
A	9/10/2013	509462GCP - RELEASE PER SALES RELEASE EM2460 MRY
B	5/8/2014	510437ECP/D - ADD 6-20A DETAIL MRY
C	9/2/2014	510977ECP/D-ADD TOLERANCES AND ADDITIONAL DIMENSIONS MRY
D	9/25/2014	511024ECP/D-ADD CRIMP TERMINAL LENGTH MRY
E	2/5/2015	514047ECP/D- ADD 25-30A DETAIL, UPDATE 2.5-20A CAP DIM MRY
F	3/25/2015	514085ECP/D - ADD 4A, UPDATE DATASHEET REV MRY
G	11/3/2015	515124ECP - ADD TOLERANCE TO CRIMP DIAMETER DIM -TV
H	3/23/2016	515709ECP/D - ADD CRIMP WALL THICKNESS DIM MRY
J	6/7/2016	515977ECP/D - ADD NOTE 1 MRY
K	8/30/2016	516307ECP/D - UPDATE DATA SHEET REV MRY
L	11/8/2016	516606ECP/D - UPDATE DATA SHEET REV MRY
M	6/6/17	517430ECP/D - REMOVE DATA SHEET REVISION MRY
N	6/21/17	517749ECP/D - ADD 25-30A WALL WALL THICKNESS MRY
P	9/5/18	519812ECP/D-CHG HEADER TO INCLUDE 4.5A MRY
R	9/16/19	521247ECP/D - ADD 35-50A MRY
S	6/9/20	522410ECP/D - CHANGE HEADER TO 1-4A MRY
T	3/24/22	524962ECP/D - REMOVE 25-30A MRY

1-4A

4.5-20A

35-50A

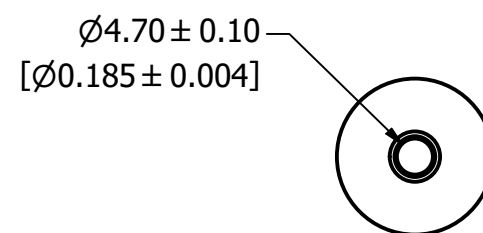
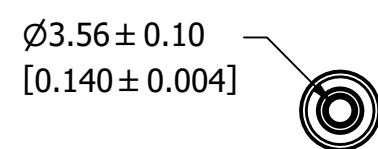
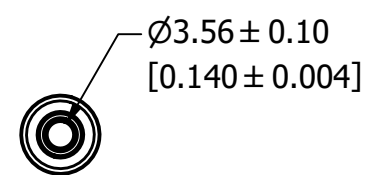
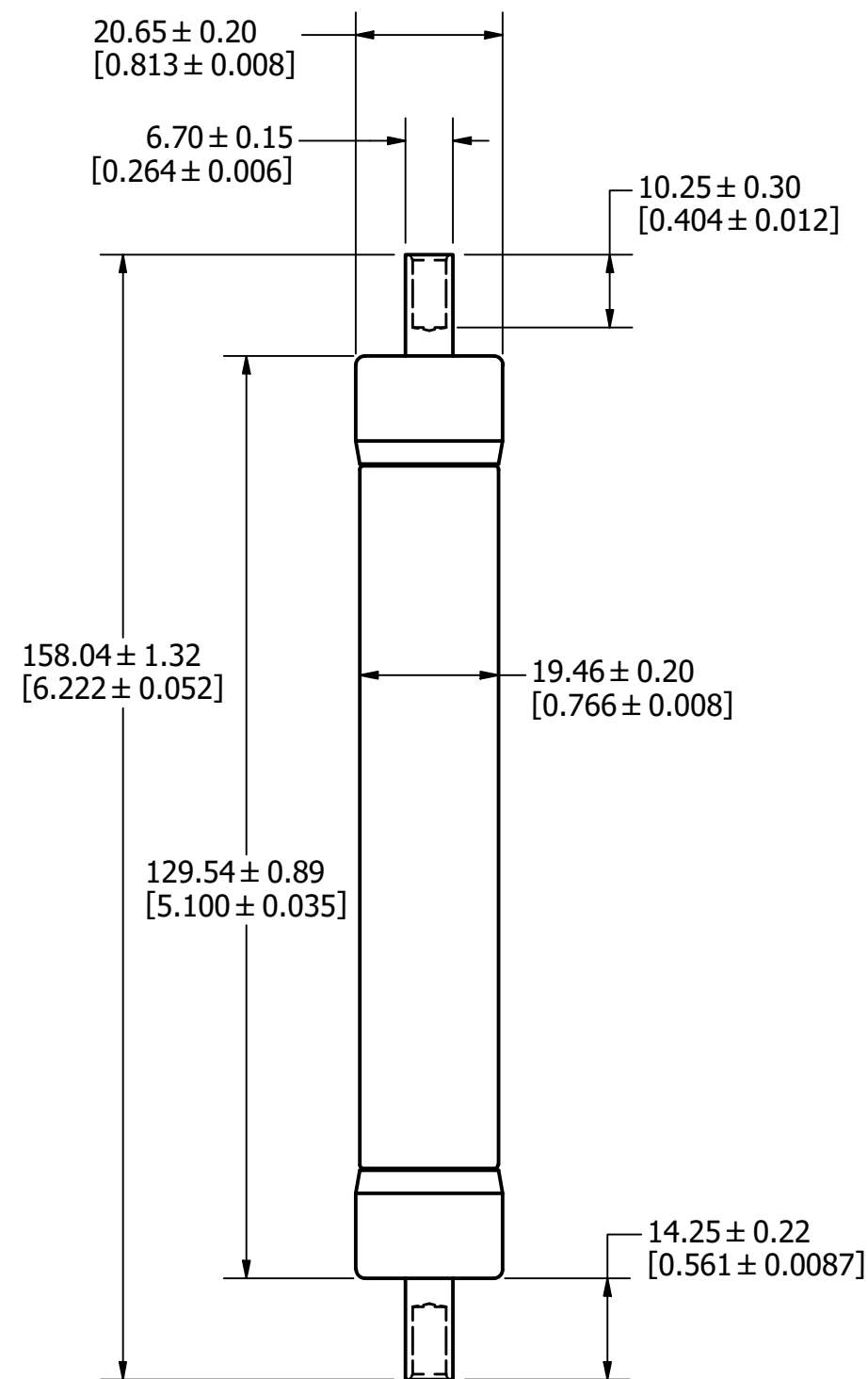
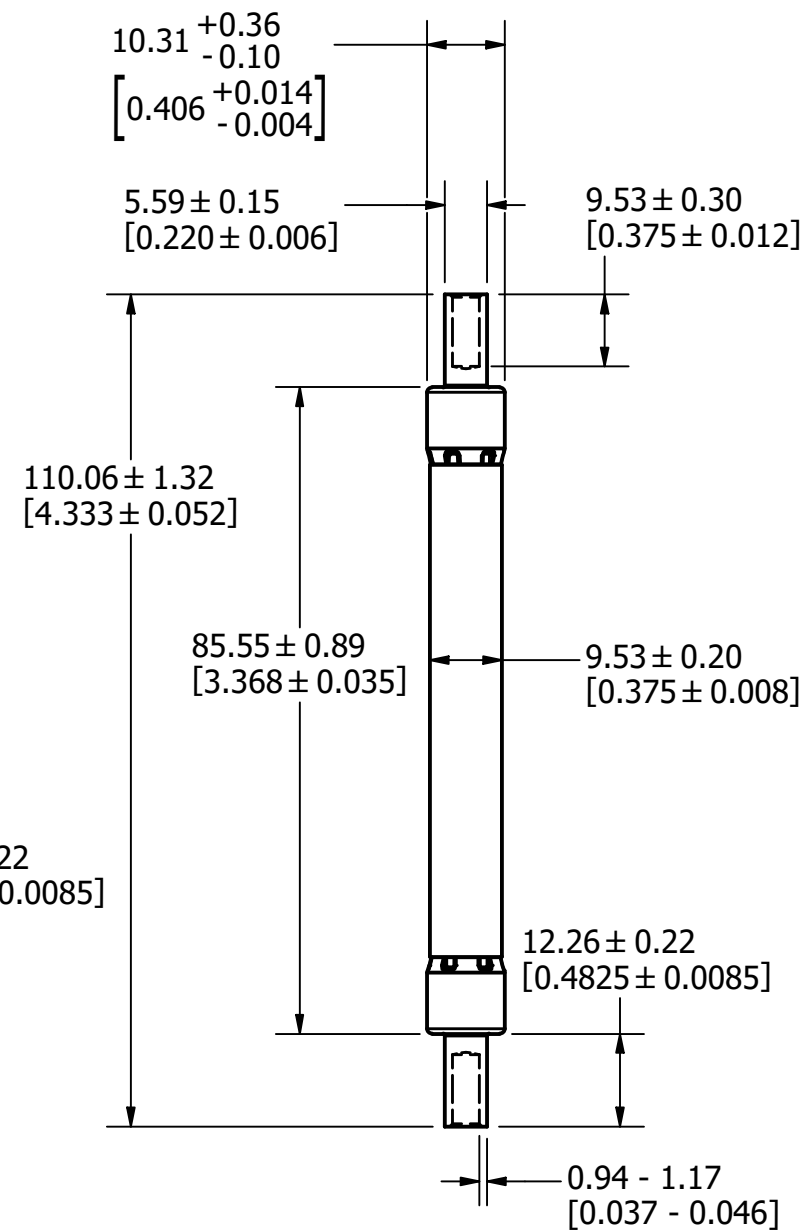
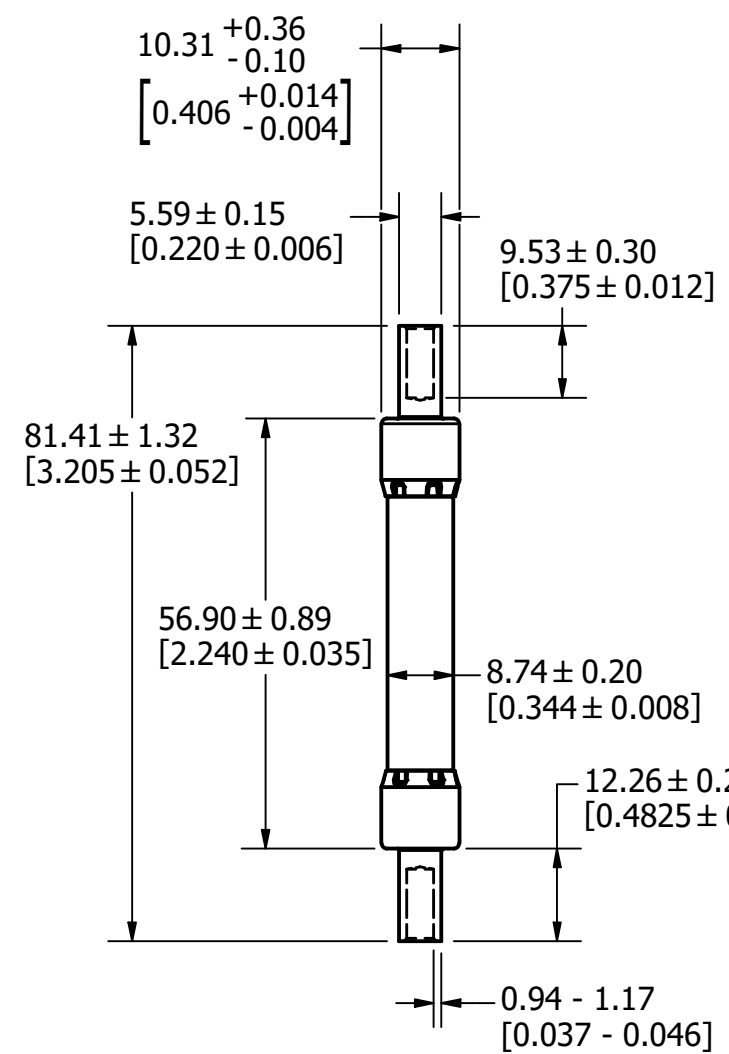

NOTE:

1. FUSES 20A AND BELOW SHALL PASS THROUGH A TUBULAR GAUGE HAVING A UNIFORM HOLE OF 0.414" MAX DIAMETER.

●	DENOTES CRITICAL CHARACTERISTICS.
CPK	DENOTES CPK DIMENSIONS, -MINIMUM CPK VALUE
(ST)	DENOTES A CHARACTERISTIC THAT PROVIDES AN INDICATION OF PROCESS PERFORMANCE. PROCEDURE FOR MEASUREMENT AND TRACKING TO BE DEFINED IN LITTELFUSE INSPECTION INSTRUCTIONS.
CP	DENOTES CP DIMENSIONS, -MINIMUM CP VALUE MUST BE WITHIN THE DIMENSIONAL LIMITATIONS SHOWN ON DRAWING AND INITIALLY LOCATED TO ALLOW FOR MAXIMUM TOOL LIFE.

MATL SPEC	FINISH		
DRW MYORK	DATE 1/17/2013	SCALE NTS	FINISH GOOD WT GRAMS/PIECE

UNLESS OTHERWISE SPECIFIED, DIMENSIONS ARE IN MILLIMETERS, DIMENSIONS IN BRACKETS [] ARE INCHES DIMENSIONING AND DO NOT INCLUDE PLATING. TOLERANCING TO BE INTERPRETED IN ACCORDANCE WITH ANSI Y14.5M-1994

3RD ANGLE PROJECTION	
----------------------	--

TITLE SPXI SERIES OUTLINE

CHICAGO, ILLINOIS 60631	REVISION T	DRWG NO. OL-SPXI000	SHEET 1 OF 1
-------------------------	------------	---------------------	--------------