

# SP1120-01WTG

## 20 V, 50 pF, 5 A, Flipchip, Unidirectional Discrete TVS Diode, General Purpose ESD Protection

**HF** **RoHS** **Pb**

### Pinout

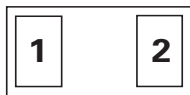

### Functional Block Diagram

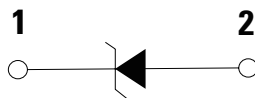

### Description

The SP1120-01WTG uni-directional TVS is fabricated in a proprietary silicon avalanche technology. These diodes provide a high ESD (electrostatic discharge) protection level for electronic equipment.

The SP1120-01WTG TVS can safely absorb repetitive ESD strikes of  $\pm 30$  kV (contact and air discharge as defined in IEC 61000-4-2) without any performance degradation. In addition, it can safely dissipate a 5 A 8/20  $\mu$ s surge event as defined in IEC 61000-4-5, 2nd edition.

### Features

- ESD, IEC 61000-4-2,  $\pm 30$  kV contact/air
- EFT, IEC 61000-4-4, 40 A (5/50 ns)
- Maximum surge tolerance, IEC 61000-4-5 2<sup>nd</sup> edition, 5 A (8/20  $\mu$ s)
- Low leakage current of 100 nA (Max) at 20 V
- Halogen free, lead free and RoHS compliant
- Moisture Sensitivity Level (MSL-1)

### Applications

- CC/SBU for USB PD3.1
- LCD/PDP TVs
- Mobile Phones
- Set Top Boxes

#### Life Support Note:

Not Intended for Use in Life Support or Life Saving Applications

The products shown herein are not designed for use in life sustaining or life saving applications unless otherwise expressly indicated.

# SP1120-01WTG

## 20 V, 50 pF, 5 A, Flipchip, Unidirectional Discrete TVS Diode, General Purpose ESD Protection

### Absolute Maximum Ratings

Symbol	Parameter	Value	Units
$I_{PP}$	Peak Current ( $t_p = 8/20 \mu s$ )	5	A
$T_{OP}$	Operating Temperature	-40 to 125	°C
$T_{STOR}$	Storage Temperature	-55 to 150	°C

**Caution:** Stresses above those listed in "Absolute Maximum Ratings" may cause permanent damage to the component. This is a stress only rating and operation of the component at these or any other conditions above those indicated in the operational sections of this specification is not implied.

### Electrical Characteristics ( $T_{OP} = 25 \text{ }^\circ\text{C}$ )

Parameter	Symbol	Test Conditions	Min	Typ	Max	Units
Reverse Standoff Voltage	$V_{RWM}$				20	V
Breakdown Voltage	$V_{BR}$	$I_R = 1 \text{ mA}$	21.0	22.5	24.0	V
Reverse Leakage Current	$I_{LEAK}$	$V_R = 20 \text{ V}$			100	nA
Clamp Voltage <sup>1</sup>	$V_C$	$I_{PP} = 1 \text{ A}, t_p = 8/20 \mu s, I/O \text{ to GND}$		22.0		V
		$I_{PP} = 5 \text{ A}, t_p = 8/20 \mu s, I/O \text{ to GND}$		32.0		V
Clamp Voltage <sup>2</sup>		8 kV(IEC), $t_p = 0.2/100 \text{ ns}$ (TLP), I/O to GND			30.0	V
Dynamic Resistance <sup>1,2</sup>	$R_{DYN}$	TLP, $t_p = 100 \text{ ns}, I/O \text{ to GND}$		0.55		$\Omega$
ESD Withstand Voltage <sup>1,3</sup>	$V_{ESD}$	IEC 61000-4-2 (Contact Discharge)	$\pm 30$			kV
		IEC 61000-4-2 (Air Discharge)	$\pm 30$			kV
Diode Capacitance <sup>1</sup>	$C_{IO-GND}$	Reverse Bias = 0 V, $f = 1 \text{ MHz}, I/O \text{ to GND}$			50	pF

**Note:**

- Parameter is guaranteed by design and/or component characterization
- Transmission Line Pulse (TLP) with 100 ns width, 0.2 ns rise time, and average window  $t_1 = 70 \text{ ns}$  to  $t_2 = 90 \text{ ns}$
- Device stressed with ten non-repetitive ESD pulses according to IEC61000-4-2 ( $R = 330 \Omega, C = 150 \text{ pF}$ ).

#### Capacitance vs. Reverse Bias

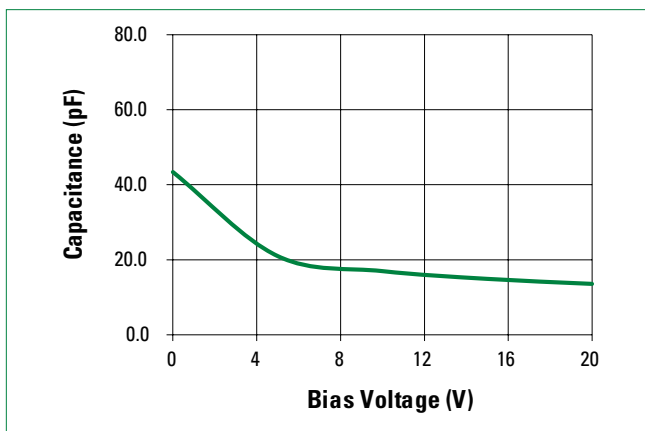

#### Clamping Voltage vs $I_{PP}$

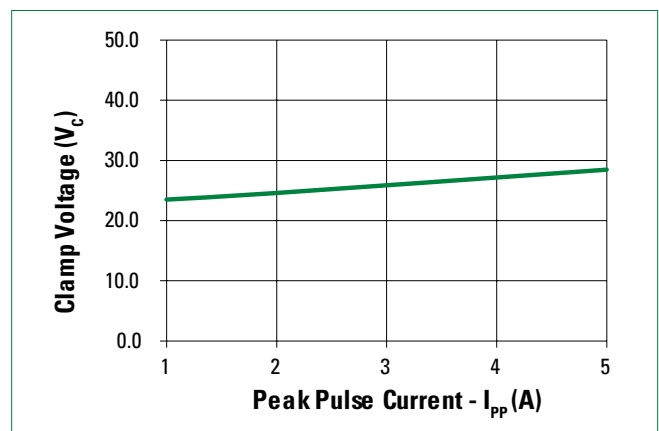

# SP1120-01WTG

20 V, 50 pF, 5 A, Flipchip, Unidirectional Discrete TVS Diode, General Purpose ESD Protection

Positive Transmission Line Pulsing (TLP) Plot

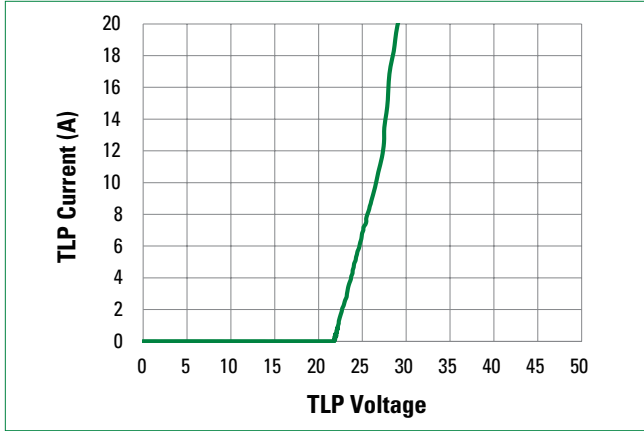

Negative Transmission Line Pulsing (TLP) Plot

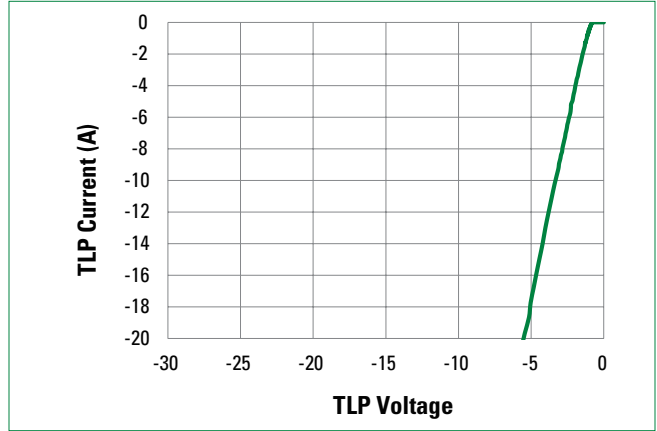

IEC 61000-4-2 +8 kV Contact ESD Clamping Voltage

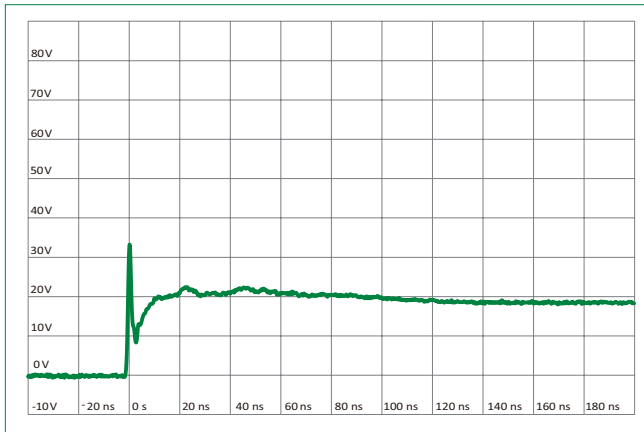

IEC 61000-4-2 -8 kV Contact ESD Clamping Voltage

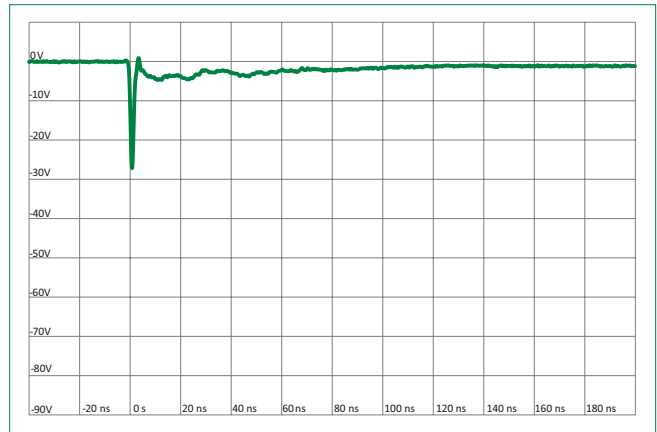

# SP1120-01WTG

## 20 V, 50 pF, 5 A, Flipchip, Unidirectional Discrete TVS Diode, General Purpose ESD Protection

### Soldering Parameters

<b>Reflow Condition</b>		Pb – Free assembly
<b>Pre Heat</b>	- Temperature Min ( $T_{s(min)}$ )	150 °C
	- Temperature Max ( $T_{s(max)}$ )	200 °C
	- Time (min to max) ( $t_s$ )	60 – 120 seconds
<b>Average Ramp Up Rate (Liquidus) Temp (<math>T_L</math>) to Peak</b>		3 °C/second max
<b><math>T_{s(max)}</math> to <math>T_L</math> - Ramp-up Rate</b>		3 °C/second max
<b>Reflow</b>	- Temperature ( $T_L$ ) (Liquidus)	217°C
	- Temperature ( $t_L$ )	60 – 150 seconds
<b>Peak Temperature (<math>T_p</math>)</b>		260 <sup>+0/-5</sup> °C
<b>Time Within 5 °C of Actual Peak Temperature (<math>t_p</math>)</b>		30 seconds max
<b>Ramp-down Rate</b>		6 °C/second max
<b>Time 25 °C to Peak Temperature (<math>T_p</math>)</b>		8 minutes max
<b>Do Not Exceed</b>		260 °C

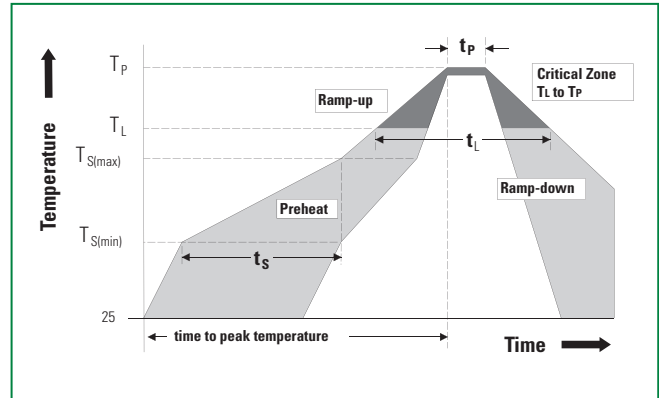

### Ordering Information

Part Number	Package	Min. Order Qty.
SP1120-01WTG	Flipchip	10000

### Product Characteristics

<b>Lead Plating</b>	Tin plating
<b>Lead Material</b>	Copper bump
<b>Flammability</b>	UL recognized compound meeting flammability rating V-0

### Part Marking System



### Part Numbering System

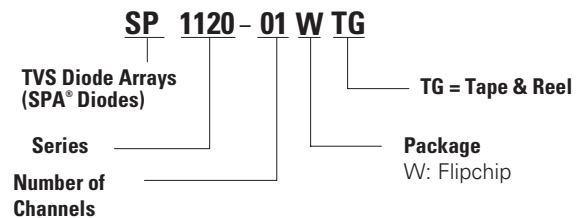

**SP1120-01WTG**

20 V, 50 pF, 5 A, Flipchip, Unidirectional Discrete TVS Diode, General Purpose ESD Protection

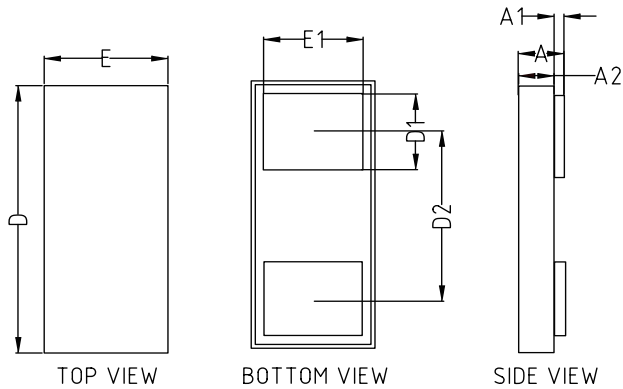
**Package Dimensions – Flipchip**

Symbol	Millimeters		Inches	
	Min.	Max.	Min.	Max.
D	0.605	0.655	0.0238	0.0258
E	0.305	0.355	0.0120	0.0140
D1	0.145	0.155	0.0057	0.0061
E1	0.245	0.255	0.0096	0.0100
D2	0.400 BSC		0.0157 BSC	
A	0.273	0.329	0.0107	0.0130
A2	0.265	0.315	0.0104	0.0124
A1	0.008	0.014	0.0003	0.0006

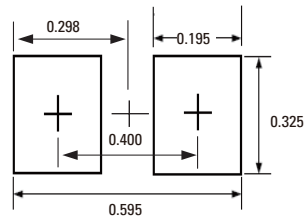

Recommended Soldering Pad Layout (mm)

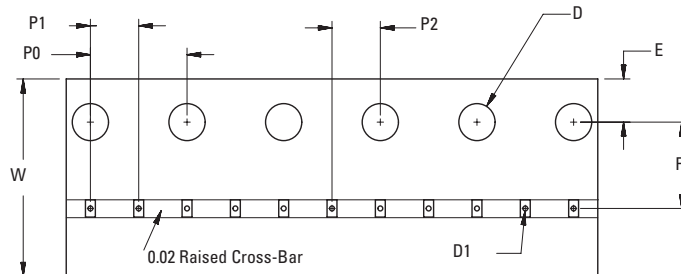
**Embossed Carrier Tape & Reel Specification – Flipchip**

Symbol	Millimeters
A0	0.39 +/-0.03
B0	0.69 +/-0.03
D	∅ 1.50 +0.10
D1	∅ 0.20 +/-0.05
E	1.75 +/-0.10
F	3.50 +/-0.05
K0	0.35 +/-0.03
P0	4.00 +/-0.10
P1	2.00 +/-0.05
P2	2.00 +/-0.05
W	8.00 +0.30/-0.10
T	0.20 +/-0.02

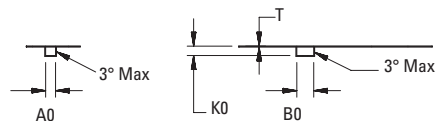

Component Orientation in Tape

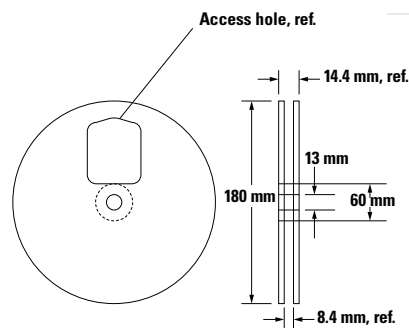
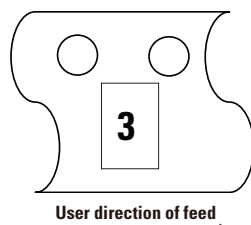

8 mm Tape and Reel

**Disclaimer Notice** - Information furnished is believed to be accurate and reliable. However, users should independently evaluate the suitability of and test each product selected for their own applications. Littelfuse products are not designed for, and may not be used in, all applications. Read complete Disclaimer Notice at <http://www.littelfuse.com/disclaimer-electronics>.