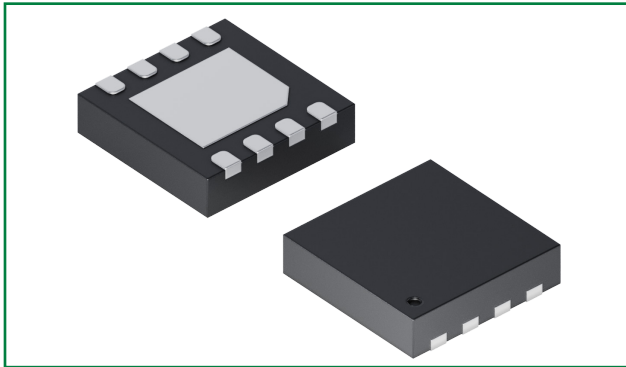

CPC1601M

Low Current, 60V, 2A

1-Form-A Solid State Latching Relay

**Features**

- Small 3 × 3 mm DFN package
- V_{CCIN}/P_{OUT} pin Input Current < 1 μ A
- Single pulse operation On/Off
- Low typical on-resistance of 308 m Ω
- Load Connect RYL1/ RLY2: 60 V_P AC or DC operation
- 2A continuous load capability AC or DC
- Set/Reset or Toggle operation
- Latching Form-A switch output
- Supply input power voltage: 3 V–5.5 V
- Zero current from system power supply when load biased power mode (load-powered) is used
- Load-harvesting power pin for powering external circuitry up to 10 mW
- Zero current switching in load-powered mode
- No auxiliary power supply needed in load-powered mode e.g. no thermostat common wire "C" lead required
- External galvanic isolation compatible

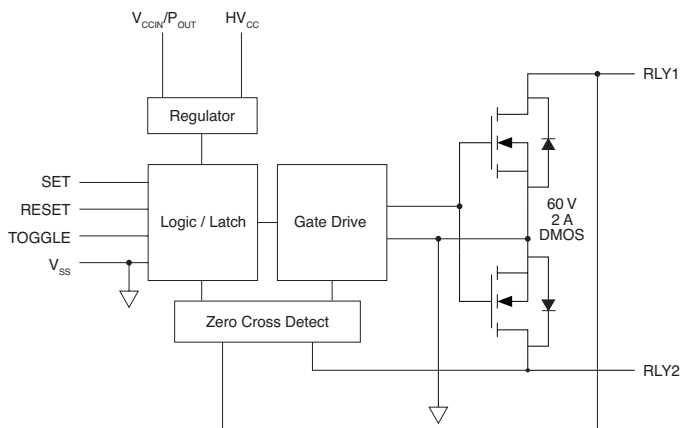
CPC1601M Functional Block Diagram**Description**

The CPC1601M is a non-isolated, low operating current, 1-Form-A solid state latching relay, integrated in a small 3 × 3 mm DFN package. The relay can obtain operating power either from the open-circuit load or from system power supply. When powered by the load, the relay consumes no power from the system supply, thus helping to extend battery life. The relay periodically opens, allowing it to harvest power from the open-circuit load voltage. In most applications, this brief interruption is unnoticeable to the load.

Additionally, the CPC1601M includes a power output pin that can supply external circuits with a maximum of 10 mW of power. The CPC1601M can sense whether it is powered by the load or by the system power supply automatically by monitoring the HV_{CC} input pin. The load-powered mode of operation applies to an AC source, such as a 24 V_{AC} transformer secondary voltage.

Galvanic isolation can be achieved by incorporating few passive components into the circuit.

Applications

- Thermostats
- HVAC
- Fire alarm panels
- Security systems
- Building automation
- Industrial controls
- Metering
- Electronic switching
- Data acquisition
- Instrumentation

Ordering Information

Part Number	Description
CPC1601MTR	8-pin DFN in Tape and Reel; 2000 per reel

1 Specifications	3
1.1 Package Pinout	3
1.2 Pin Description	3
1.3 Absolute Maximum Ratings	3
1.4 Electrical Characteristics @ 25 °C (Unless otherwise noted)	4
1.5 Load Current Derating Curve	4
2 Functional Description	5
2.1 Load-powered Mode	5
2.1.1 Load-powered Cycle Description:	5
2.2 Load-powered Mode	6
2.3 Load-powered Mode with Zero-Cross Detection Mode	6
2.4 System Power Mode	7
2.5 Relay Mode Timing	7
2.6 Galvanic Isolation	8
2.7 Alternative Method for Galvanic Isolation "Reduced Component Count"	9
3 Manufacturing Information	10
3.1 Moisture Sensitivity	10
3.2 ESD Sensitivity	10
3.3 Soldering Profile	10
3.4 Board Wash	10
3.5 Mechanical Dimensions	11
3.5.1 CPC1601M 8-Pin DFN Package	11
3.5.2 CPC1601M 8-Pin Package Tape and Reel	11

1 Specifications

1.1 Package Pinout

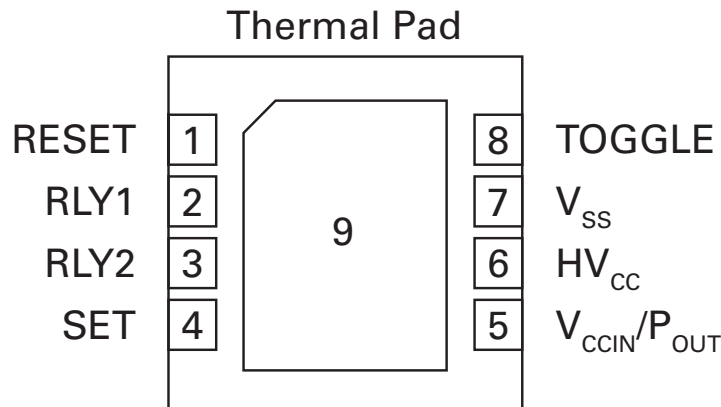

1.2 Pin Description

Pin	Name	Type	Description
1	RESET	Input	Logic input with an active high pulse turns the relay OFF. Connect to ground if using TOGGLE pin.
2	RLY1	Bidirectional	Connect to load.
3	RLY2	Bidirectional	Connect to load.
4	SET	Input	Logic input with an active high pulse turns the relay ON. Connect to ground if using TOGGLE pin.
5	V _{CCIN} /P _{OUT}	Bidirectional	When operating in load-powered mode, V _{CCIN} /P _{OUT} is a 3 V to 5 V output that can be used to power external circuitry. When not operating in load-powered mode, this pin is connected to the system power supply.
6	HV _{CC}	Input	DC power input to the relay when operating in load-powered mode. Do not connect if CPC1601M is powered by an external supply other than the load supply i.e. battery on V _{CCIN} /P _{OUT} pin.
7	V _{SS}	Input	Connect to system power supply return.
8	TOGGLE	Input	Active high pulse alternately turns relay ON and OFF.
9	Thermal Pad	Input	Thermal Pad should be connected to system power supply return.

1.3 Absolute Maximum Ratings

(T_a = 25 °C unless otherwise noted)

Parameter	Rating	Units
Blocking Voltage	60	V _{DC}
HV _{CC} Supply Voltage	60	V _{DC}
V _{CCIN} /P _{OUT} Supply Voltage	6	V _{DC}
Total Power Dissipation ¹	2	W
ESD Rating, Human Body Model	2000	V
Operating Temperature, Ambient	-40 to +85	°C
Storage Temperature	-40 to +150	°C

¹ Derate 22 mW/K above 40 °C ambient.

Absolute Maximum Ratings are stress ratings. Stresses in excess of these ratings can cause permanent damage to the device. Functional operation of the device at conditions beyond those indicated in the operational sections of this data sheet is not implied.

Typical values are characteristic of the device at +25 °C, and are the result of engineering evaluations. They are provided for information purposes only, and are not part of the manufacturing testing requirements.

1.4 Electrical Characteristics @ 25°C (Unless otherwise noted)

Parameter	Condition	Symbol	Min	Typ	Max	Units
Load Current, continuous	$T_a \leq 40^\circ\text{C}$ (see derating curve in 1.5)	I_L	—	—	2	A
On-Resistance	$T_a = +25^\circ\text{C}$	R_{ON}	—	308	365	mΩ
	$V_{CCIN} = 3\text{ V}, I_L = 400\text{ mA}, +85^\circ\text{C}$		—	—	520	
Off-State Leakage Current	$V_L = 60\text{ V}$	I_{LEAK}	—	—	1	μA
Switching Speeds						
Turn-On *	SET or TOGGLE pulse applied	t_{on}	—	—	1	μs
Turn-Off *	RESET or TOGGLE pulse applied	t_{off}	—	—	1	
Output Capacitance	$V_L = 20\text{ V}, f = 1\text{ MHz}$	C_{OUT}	—	98	—	pF
Input Voltage, High (SET, RESET, TOGGLE)	—	V_{IH}	1.4	—	—	V
Input Voltage, Low (SET, RESET, TOGGLE)	—	V_{IL}	—	—	0.5	
Input Hysteresis (SET, RESET, TOGGLE)	—	V_{HYS}	—	0.1	—	
V_{CCIN}/P_{OUT} Supply Output Voltage	Load-powered mode output	V_{CCOUT}	3	—	5	V_{DC}
V_{CCIN}/P_{OUT} Supply Input Voltage	System power	V_{CCIN}	3	—	5.5	
V_{CCIN}/P_{OUT} Supply Input Current	Input voltage = 5 V	I_{VCC}	—	—	1	μA
HV_{CC} Supply Voltage	Load-powered mode input	HV_{CC}	—	—	60	V_{DC}
V_{CCIN}/P_{OUT} Supply Output Current	Load-powered mode output	I_{OCC}	—	—	2	mA
HV_{CC} Supply Current	—	I_{HVCC}	—	—	250	μA
Load-powered mode Relay OFF Voltage	—	HV_{CC_off}	—	10	—	V
Load-powered mode Relay ON Voltage	—	HV_{CC_on}	—	20	—	

* Refer to Figure 9

1.5 Load Current Derating Curve

Assumes 8-lead $3 \times 3\text{ mm}^2$ DFN with hi-K JEDEC board 22 inch 1 oz Cu and thermal vias connected to Pad.

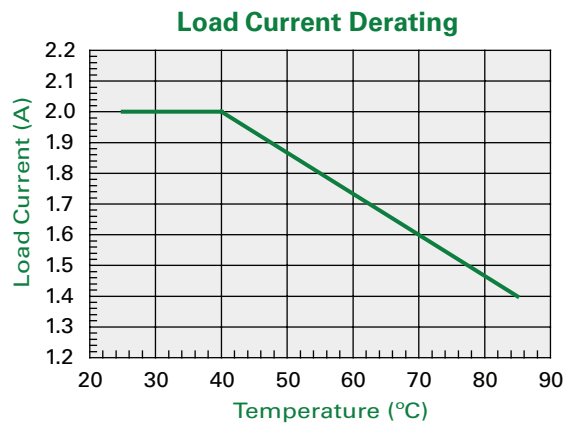

2 Functional Description

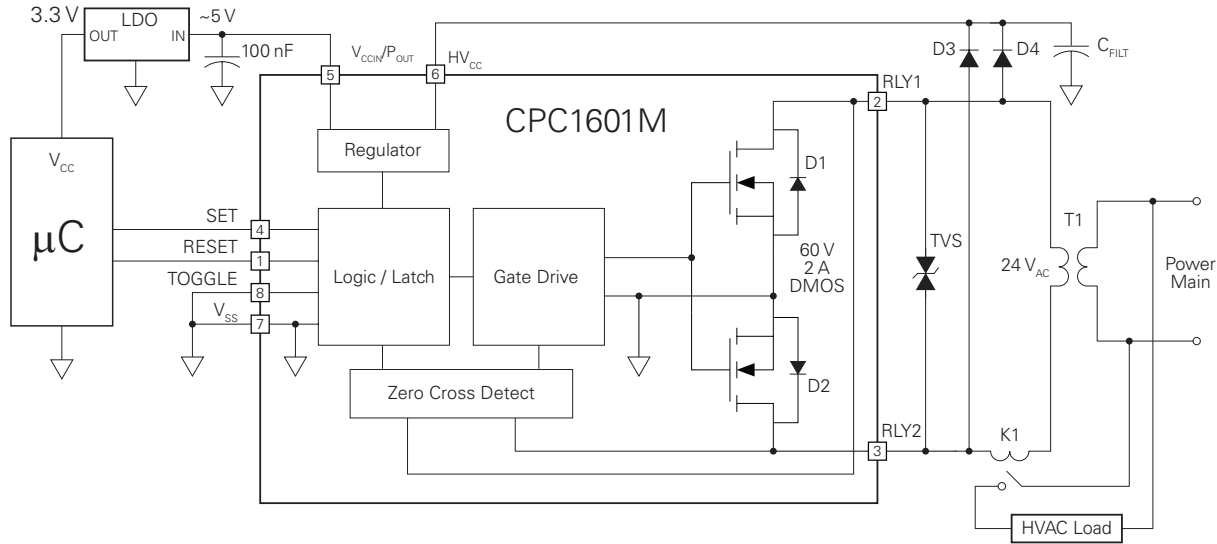

Figure 1 CPC1601M: Load-powered Mode Application

2.1 Load-powered Mode

Figure 1 illustrates an application in which a thermostat is used to drive a contactor relay (K1) in heating, ventilation, air conditioning (HVAC) systems. The contactor is usually a high current electromagnetic relay that switches the HVAC load. In Figure 1, K1 is controlled by turning the CPC1601M relay on and off.

When the CPC1601M is in the OFF mode, the full open-circuit voltage from transformer T1 is seen across the load output pins RLY1 and RLY2. This AC voltage is full-wave rectified by internal DMOS body diodes, denoted by D1 and D2, and external diodes D3 and D4. The full-wave rectified output signal is presented to filter capacitor C_{FILT} , which acts as a reservoir capacitor when operating in load-powered mode. Additionally, a voltage output is made available at the V_{CCIN}/P_{OUT} pin where it can be used to power the μC and external circuitry. A low drop regulator (LDO) may not be required if the voltage output is within the operating range of the μC that is used. A transient voltage suppressor diode (TVS) is placed across the load output pins RLY1 and RLY2 to protect the switch output from reverse transients when switching an inductive load.

2.1.1 Load-powered Cycle Description:

When the CPC1601M is off, C_{FILT} is fully charged with the voltage described by Equation 1:

Equation 1:

$$V(C_{FILT}) = (\sqrt{2} \cdot V_{AC}) - 2V_F$$

where V_{AC} is the voltage on C_{FILT} and V_F is the forward voltage drop of the diode.

When the relay is commanded to turn on, the load-powered cycle begins. The change in voltage is described

by Equation 2 where 'I' represents the current into the HV_{CC} pin and Δt is the desired time between load-powered cycles. It is important to note that the total current also includes any current drawn from the V_{CCIN}/P_{OUT} pin if this pin is connected to external circuitry.

During the load-powered cycle when the relay is off, C_{FILT} is charged to 20 V before the relay turns on. When the relay turns on, the voltage across C_{FILT} starts to drop as C_{FILT} discharges. When the voltage across C_{FILT} reaches approximately 10 V, the relay will turn off at approximately zero current as detected by the zero cross detect circuit. This cycle repeats for as long as the HVAC relay remains in the on state.

The maximum relay off voltage is 10 V, and the minimum relay on voltage is 20 V, therefore, $\Delta V = (20V - 10V) = 10V$. By using this ΔV , the designer can trade off load-powered time to size of C_{FILT} . The charge time during load-powered cycle mode depends on the source impedance of the load, but is generally a small fraction of an AC cycle. Typical charge times can range from a few hundred μs to around 3 ms for typical loads.

$$\text{Equation 2: } \Delta V_{DC} = \frac{I \Delta t}{C_{FILT}}$$

Rearranging Equation 2 to solve for the desired load-powered cycle time:

$$\text{Equation 3: } \Delta t = \frac{C_{FILT} \cdot \Delta V}{I}$$

As an example, assume $I = 130 \mu A$ and $C_{FILT} = 2.2 \mu F$, the load-powered cycle time Δt will be 169 ms.

2.2 Load-powered Mode

In Load-powered mode, the V_{CCIN}/P_{OUT} pin is an output that provides a voltage between 3 V and 5 V and that can be used as an input to an external voltage regulator to power external circuitry. In some cases, the V_{CCIN}/P_{OUT} pin can be used to power user circuitry directly without the use of a regulator, depending on the external circuit requirements. Figure 2 shows a typical loading curve for the V_{CCIN}/P_{OUT} pin.

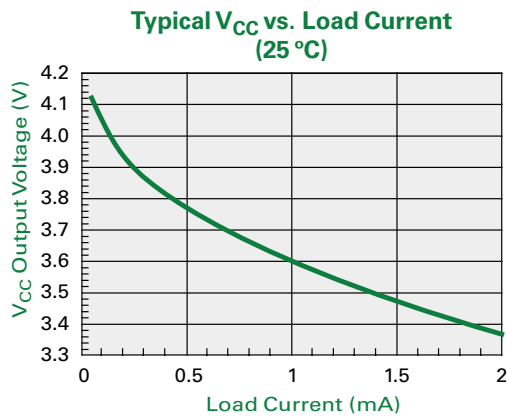

Figure 2 V_{CC} vs. Load Current

2.3 Load-powered Mode with Zero-Cross Detection Mode

In applications where driving large inductive loads is expected, opening the relay at zero-cross current has the advantage of limiting back EMF that can generate EMI and other noise. This mode of operation can be selected by using the SET, RESET, and TOGGLE pins in a certain sequence as follows:

Referring to Figure 3, RESET must be high for t_{SU} before the TOGGLE input makes the low to high transition that changes the device mode. And RESET must stay high t_H after the rising edge. $t_{SU} = t_H \geq 100$ ns

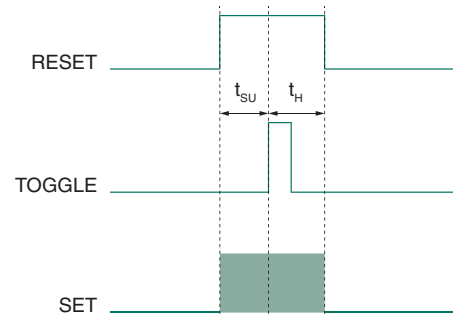

Figure 3 Zero Crossing Mode Control

If the SET input is also high for the rising edge of TOGGLE, the zero-crossing mode is enabled in load-powered mode. In this mode, the device will wait after a RESET, or TOGGLE command for the load current to be close to zero before switching the relay into the off state.

If the SET input is low for the rising edge of TOGGLE, the zero-crossing mode is disabled, and the device will operate normally. The off state will trigger immediately with a RESET or TOGGLE command. This is the state after a power-on reset occurs.

2.4 System Power Mode

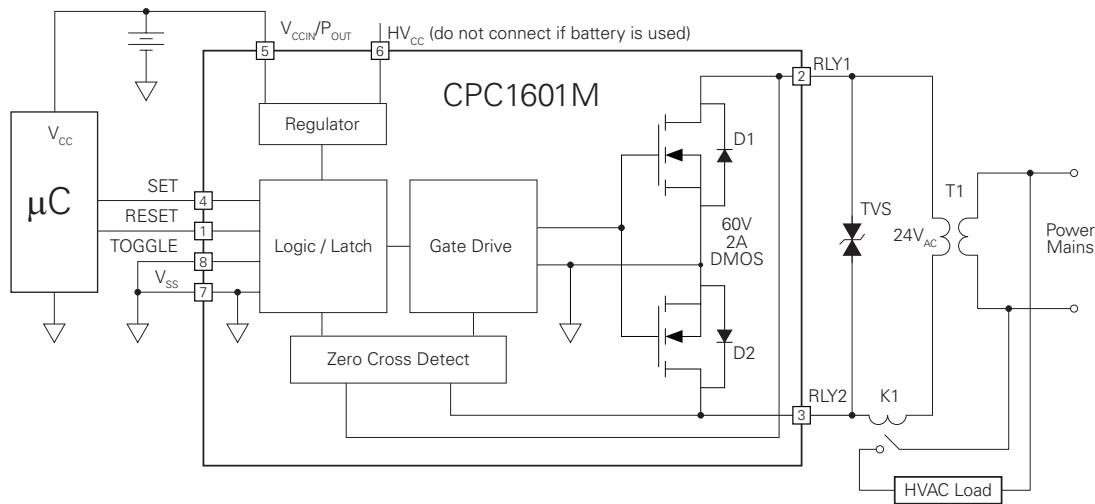

Figure 4 System Power Mode Application

In System Power mode of operation, power for the CPC1601M is derived from the power supply and not the load. In a typical thermostat application, the power source is usually a battery. Due to the extremely low power requirements of the CPC1601M, it makes an excellent choice for applications where extending battery life is of utmost importance.

Referring to Figure 4, the CPC1601M V_{CCIN}/P_{OUT} pin is connected to the system battery and the HV_{CC} pin is left open. In this mode the CPC1601M acts as a simple latching relay that can be controlled by using SET and RESET, or in the TOGGLE mode.

2.5 Relay Mode Timing

Function	Conditions	Load-powered Mode	System Power Mode	Load-powered Mode Zero Cross, Current Enabled
SET Activation Time	Positive Edge	< 1 μ s	< 1 μ s	< 1 μ s
RESET Deactivation Time	Positive Edge	< 1 μ s	< 1 μ s	$\leq \frac{1}{2}$ AC Cycle

2.6 Galvanic Isolation

Some applications may require electrical isolation. This is common in dual transformer HVAC systems where the transformer returns are separate and isolated from each

other. The circuit shown in Figure 5 can be used to achieve the required isolation by utilizing capacitive coupling of a PWM signal.

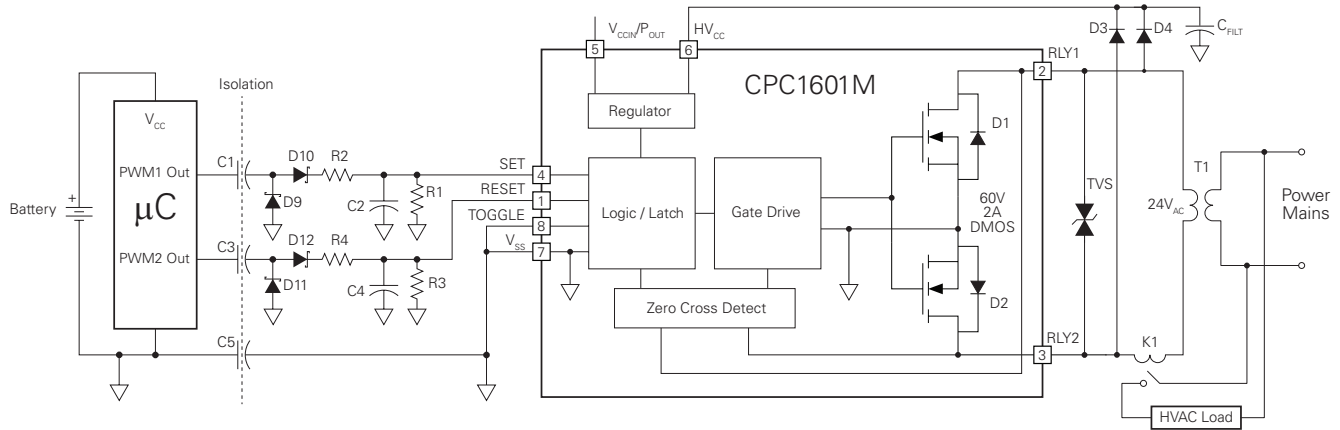

Figure 5 Application Employing Galvanic Isolation

Referring to Figure 5, the µC (Micro Controller) generates several multiple cycles of a PWM signal that is capacitively coupled by isolation capacitor C1. This PWM signal is filtered by R2 and C2 thus creating a DC signal that is used to trigger the SET input of the CPC1601M. The RESET circuit is identical to the SET circuit and is driven by another PWM output signal from the µC.

Diode D9 provides a discharge path for C1 when the PWM signal goes low while diode D10 is used to charge C2 and prevent the charge on C2 from discharging through R2. Capacitor C2 holds the charge until the PWM goes low and then discharges through R1 setting the decay time.

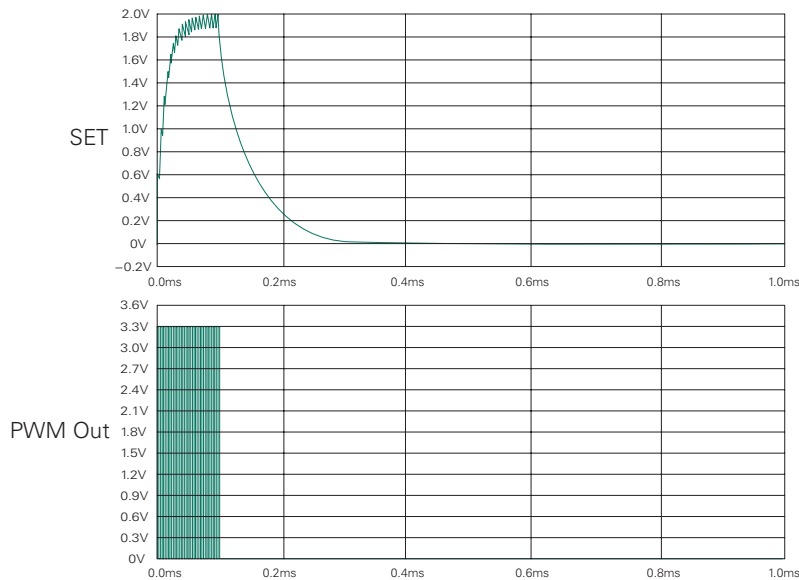

Figure 6 PWM and SET Waveforms

Referring to Figure 6, the top trace is the SET input, and the bottom trace is the PWM output of the µC, in this case 20 cycles at 200kHz. For the values chosen, the SET input rises to approximately 1.9V noting that the minimum SET on voltage is 1.5V from the Electrical Specifications table. The component values used in the circuit shown in Figure 5 are:

- R1 = 47 kΩ
- R2 = 10 kΩ
- C1 = 1nF
- C3 = 0.001 µF

The PWM signal out of the µC is a 200kHz, 50% duty cycle square wave. Component values can be modified to suit system requirements.

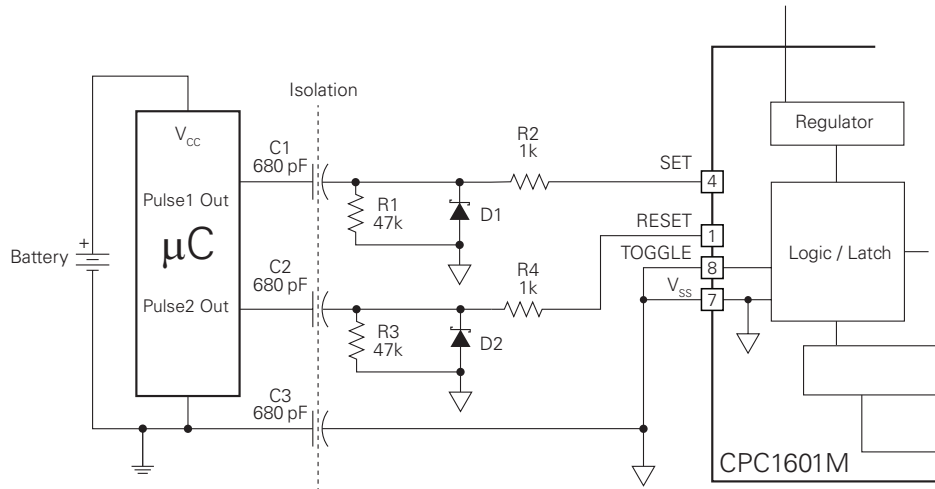

Figure 7 PWM1 Circuit Example for Galvanic Isolation

2.7 Alternative Method for Galvanic Isolation “Reduced Component Count”

An alternate method may be used with addition of a few passive components to achieve SET and RESET function with no microcontroller PWM support. C1, C3, and R1 comprise a differentiator circuit to differentiate the rising and falling edge of the microcontroller control signal. Schottky diode D1 clamps the negative-going input voltage to approximately $-0.4V$, as shown by the green trace in Figure 8. Resistor R2 limits the input current to a safe level. When the Set output of the microcontroller transitions from 0 to 1, the C1/R1 combination differentiates the edge to provide a single pulse to the Set input of the CPC1601M. This circuit is repeated for the Reset circuit as well. Values can be adjusted by the designer to control pulse amplitude.

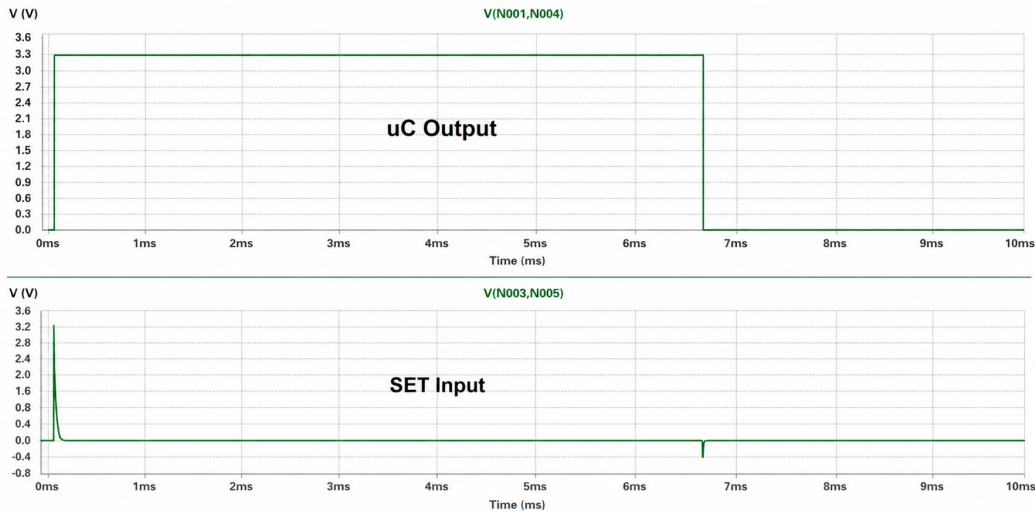

Figure 8 Input waveform

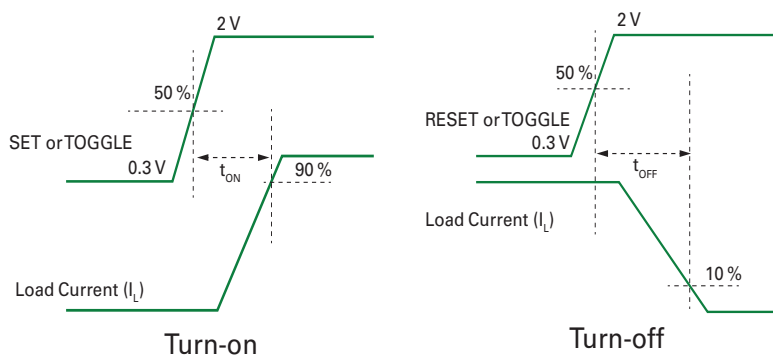

Figure 9 Switch Timing Waveforms

3 Manufacturing Information

3.1 Moisture Sensitivity



All plastic encapsulated semiconductor packages are susceptible to moisture ingress. Littelfuse classifies its plastic encapsulated devices for moisture sensitivity according to the latest revision of the joint industry standard, **IPC/JEDEC J-STD-020**, in force at the time of product evaluation. We test all of our products to the maximum conditions set forth in the standard, and guarantee proper operation of our devices when handled according to the limitations and information in that standard, as well as to any limitations set forth in the information, or standards referenced below.

Failure to adhere to the warnings or limitations as established by the listed specifications could result in reduced product performance, reduction of operable life, and/or reduction of overall reliability.

This product carries a Moisture Sensitivity Level (MSL) classification as shown below, and should be handled according to the requirements of the latest revision of the joint industry standard **IPC/JEDEC J-STD-033**.

Device	Moisture Sensitivity Level (MSL) Classification
CPC1601M	MSL1

3.2 ESD Sensitivity



This product is ESD Sensitive, and should be handled according to the industry standard **JESD-625**.

3.3 Soldering Profile

Provided in the table below is the **IPC/JEDEC J-STD-020** Classification Temperature (T_C) and the maximum dwell time ($T_C - 5^\circ\text{C}$). The Classification Temperature sets the Maximum Body Temperature allowed for these devices, during reflow soldering processes.

Device	Classification Temperature (T_C)	Dwell Time (t_p)	Maximum Reflow Cycles
CPC1601M	260°C	30 seconds	3

3.4 Board Wash

Littelfuse recommends the use of no-clean flux formulations. Board washing to reduce, or remove flux residue following the solder reflow process is acceptable, provided proper precautions are taken to prevent damage to the device. These precautions include, but are not limited to: Using a low pressure wash and providing a follow-up bake cycle sufficient to remove any moisture trapped within the device, due to the washing process. Due to the variability of the wash parameters used to clean the board, determination of the bake temperature and duration necessary to remove the moisture trapped within the package is the responsibility of the user (assembler). Cleaning, or drying methods that employ ultrasonic energy may damage the device and should not be used. Additionally, the device must not be exposed to halide flux or solvents.



3.5 Mechanical Dimensions

3.5.1 CPC1601M 8-Pin DFN Package

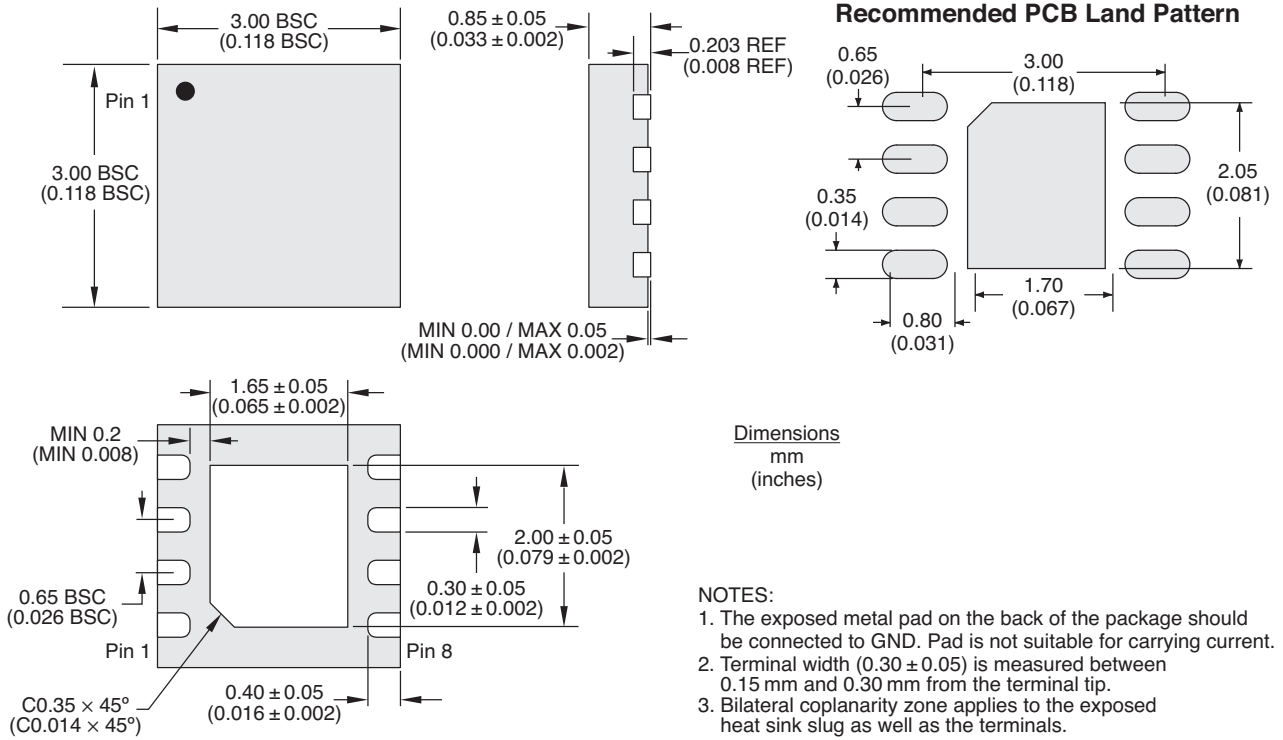

3.5.2 CPC1601M 8-Pin Package Tape and Reel

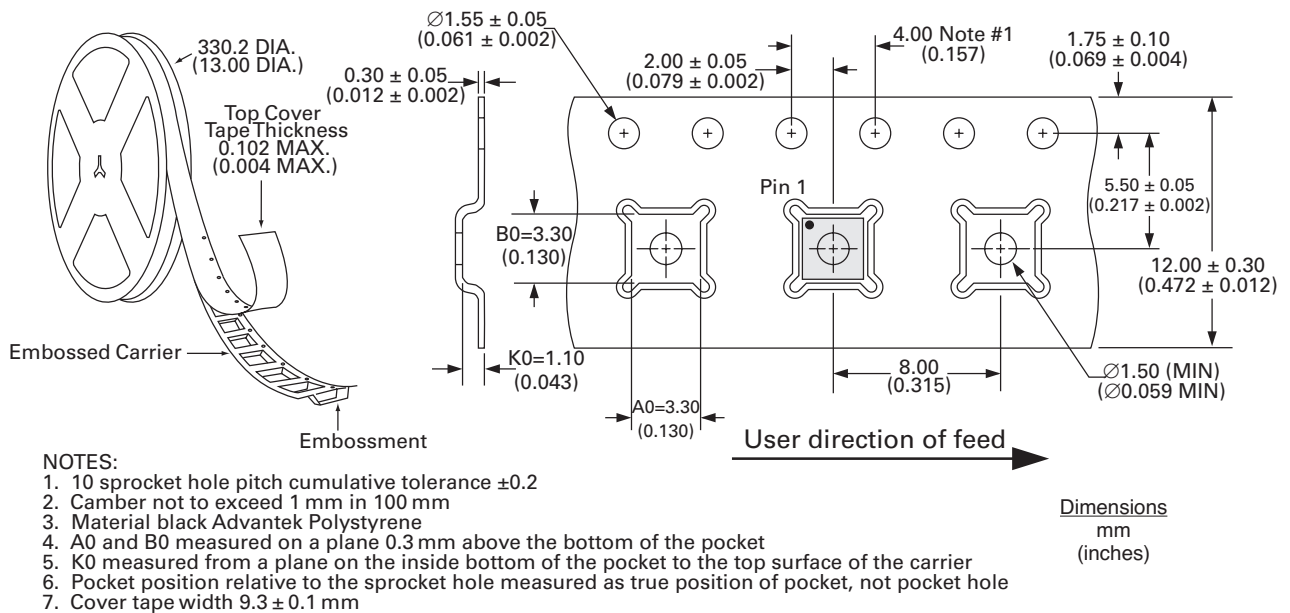

Disclaimer Notice - Information furnished is believed to be accurate and reliable. However, users should independently evaluate the suitability of and test each product selected for their own applications. Littelfuse products are not designed for, and may not be used in, all applications. Read complete Disclaimer Notice at <https://www.littelfuse.com/disclaimer-electronics>