

DCNLEV50 SERIES HIGH CURRENT HIGH VOLTAGE DC CONTACTOR RELAY



Ordering Information

Please see page 2 for more information.

Specifications Overview

Amperage:	50A Continuous Carry
Housing:	Nylon UL 94-V0
Voltage Rating:	750V
Output Connectors:	M5 Bolt and Lockwasher Connections
Connectors:	Wire Leads for Control Circuit
Ingress Protections:	IP67
Operating Temperature:	-40 to 85°C
Circuitry:	SPST NO
Coil Voltage:	B: 12V DC Nominal, 8-16V DC Working C: 24V DC Nominal, 16-28V DC Working E: 48V DC Nominal, 33-52V DC Working
Max Coil Inrush Current:	B: 461mA Max to Coil C: 250mA Max to Coil E: 122mA Max to Coil
Mounting:	M4
Size:	46mm x 58mm x 41mm
Mounting Bolt Torque:	2.3 Nm (20 in-lb)
Contact Torque:	3.4 - 4.5 Nm (30 - 40 in-lb)
Terminals:	M5 Silver Plated Copper
Approvals:	UL File No. E510407 Recognized

Description

High current and high voltage DC contactor relays for electric vehicle applications such as charging station, battery power supply, motor control, circuit protection, and other switch controls. Can also be used in uninterruptible power supply and industrial machinery. Available with polarized and non-polarized contacts to best suit electrical systems' polarity.

Features and Benefits

- High current (50A) and high voltage (900V) contactor for EV applications
- Compact structure, helping reduce noise when turned on
- Sealed IP67, gas-filled relay which mitigates arcing
- No mounting orientation restrictions
- Designed and manufactured under the IATF16949 certification for Automotive Quality Systems.
- Designed specifically for automotive applications.

Applications

- Battery Electric Vehicles
- Hybrid Electric Vehicles
- Material Handling
- Electric Maintenance and Transport Vehicles
- Industrial Applications

Web Resources

Download 2D print and technical resources at:
littelfuse.com/DCNLEV50

Electrical Diagram

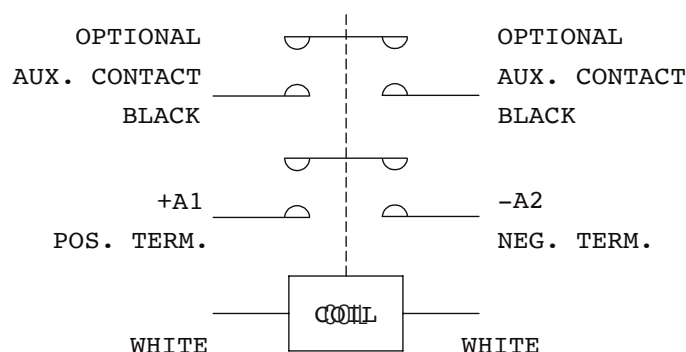

DCNLEV50 SERIES HIGH CURRENT HIGH VOLTAGE DC CONTACTOR RELAY

Ordering Information

PART NUMBER	DESCRIPTION	COIL VOLTAGE 12V DC	COIL VOLTAGE 24V DC	COIL VOLTAGE 48V DC	AUXILIARY CONTACT SPST-NO	BOTTOM MOUNT	SIDE MOUNT	NON-POLARIZED TERMINALS
DCNLEV50-BS	High Voltage DC Contactor Relay Side Mount with Polar Load Terminals	●					●	
DCNLEV50-BSN	High Voltage DC Contactor Relay Side Mount Non-Polar	●					●	●
DCNLEV50-B	High Voltage DC Contactor Relay Bottom Mount with Polar Load Terminals	●				●		
DCNLEV50-BN	High Voltage DC Contactor Relay Bottom Mount Non-Polar	●				●		●
DCNLEV50-BAS	High Voltage DC Contactor Relay Side Mount with Auxiliary Circuit with Polar Load Terminals	●			●		●	
DCNLEV50-BASN	High Voltage DC Contactor Relay Side Mount with Auxiliary Circuit Non-Polar	●			●		●	●
DCNLEV50-BA	High Voltage DC Contactor Relay Bottom Mount with Auxiliary Circuit with Polar Load Terminals	●			●	●		
DCNLEV50-BAN	High Voltage DC Contactor Relay Bottom Mount with Auxiliary Circuit Non-Polar	●			●	●		●
DCNLEV50-CS	High Voltage DC Contactor Relay Side Mount with Polar Load Terminals		●				●	
DCNLEV50-CSN	High Voltage DC Contactor Relay Side Mount Non-Polar		●				●	●
DCNLEV50-C	High Voltage DC Contactor Relay Bottom Mount with Polar Load Terminals		●			●		
DCNLEV50-CN	High Voltage DC Contactor Relay Bottom Mount Non-Polar		●			●		●
DCNLEV50-CAS	High Voltage DC Contactor Relay Side Mount with Auxiliary Circuit with Polar Load Terminals		●		●		●	
DCNLEV50-CASN	High Voltage DC Contactor Relay Side Mount with Auxiliary Circuit Non-Polar		●		●		●	●
DCNLEV50-CA	High Voltage DC Contactor Relay Bottom Mount with Auxiliary Circuit with Polar Load Terminals		●		●	●		
DCNLEV50-CAN	High Voltage DC Contactor Relay Bottom Mount with Auxiliary Circuit Non-Polar		●		●	●		●
DCNLEV50-ES	High Voltage DC Contactor Relay Side Mount with Polar Load Terminals			●			●	
DCNLEV50-ESN	High Voltage DC Contactor Relay Side Mount Non-Polar			●			●	●
DCNLEV50-E	High Voltage DC Contactor Relay Bottom Mount with Polar Load Terminals			●		●		
DCNLEV50-EN	High Voltage DC Contactor Relay Bottom Mount Non-Polar			●		●		●
DCNLEV50-EAS	High Voltage DC Contactor Relay Side Mount with Auxiliary Circuit with Polar Load Terminals			●	●		●	
DCNLEV50-EASN	High Voltage DC Contactor Relay Side Mount with Auxiliary Circuit Non-Polar			●	●		●	●
DCNLEV50-EA	High Voltage DC Contactor Relay Bottom Mount with Auxiliary Circuit with Polar Load Terminals			●	●	●		
DCNLEV50-EAN	High Voltage DC Contactor Relay Bottom Mount with Auxiliary Circuit Non-Polar			●	●	●		●

* Box Packaging Available

DCNLEV50 SERIES HIGH CURRENT HIGH VOLTAGE DC CONTACTOR RELAY

Performance Data

MAIN CONTACT	
Contact arrangement	1 Form X (SPST-NO, DM)
Rated Operating Voltage	12-750VDC
Continuous (Carry) Current	50A*1
Short term	100A (3 minutes)*2
Max short circuit current	1,250A (½ cycle, 60Hz) (through closed contacts)
Dielectric Withstanding Voltage	Between open contacts: 5,600Vrms/8,000Vdc
	Between contact and coil: 2,200Vrms/4,000Vdc
Insulation Resistance	Terminal to Terminal/Terminal to coil
	New: Min 100 MΩ @500Vdc End of life: Min 50 MΩ @500Vdc
Voltage Drop (@50A)	≤60mV

*1: Current is relevant to the cross-sectional area of conductor.

*2: Ambient temperature: +40°C, 3 minutes

COIL DATA			
Voltage rating	12Vdc	24Vdc	48Vdc
Voltage (Max.)	16Vdc	28Vdc	52Vdc
Pickup voltage (20 °C)	8Vdc	16Vdc	33Vdc
Dropout voltage (20 °C)	1.2Vdc	2.4Vdc	4.8Vdc
Coil current (20°C, voltage rating, nominal)	461mA	250mA	122mA
Coil wattage (20°C, voltage rating, nominal)	5.5W	6.0W	6.0W
Max pickup voltage (85°C)	9.6Vdc	19.2Vdc	38.4Vdc
Rated coil resistance±5% (20°C)	26 Ω	96 Ω	392 Ω

Estimated Make Break Chart

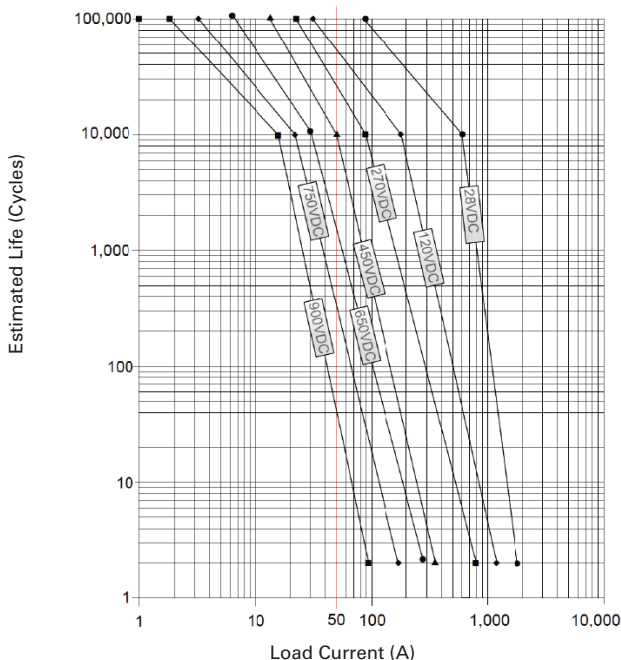

LIFE	
Electrical life	See estimated make break chart
Mechanical life	200,000 cycles

OPERATE / RELEASE TIME	
Close (includes bounce)	25ms, Max.
Release	10ms, Max.

MAX. BREAKING LIMIT	MAX. SHORT CIRCUIT
500A@320VDC, 1 cycle	500A, 1 sec

ENVIRONMENTAL DATA	
Shock, 11ms ½ sine, operating	20G Peak
Vibration, Sine, Peak, 20G	80—2,000Hz
Operating Ambient Temperature	-40 to +85°C
Weight	0.42 Lb (0.19 kg)

AUX. CONTACT	
Aux. Contact arrangement	1 Form A
Aux. Contact Current Max	2A@30VDC/ 3A@125VAC
Aux. Contact Current Min	100mA@8V
Max. Contact Resistance	0.417Ω@30VDC
	0.150Ω@125VAC

Application Note:

- Be sure to use washer to prevent screws from loosening, all the terminals or copper bar must be in direct contact with the contactor's terminals. Screw tightening torque is specified below. Exceeding the maximum torque can lead to product failure.
 - Contact torque: 30 - 40 lb.in (3.4 - 4.5 N.m) Max. Active length of thread is 7.0 mm
 - Mounting torque: 20 lb.in (2.3 N.m)
- Contact terminals are polarized so refer to drawing during connecting. We suggest using a varistor rather than diode as a surge protector.
- Do not use if dropped.
- Avoid installing in a strong magnetic field (close to a transformer or magnet), or near a heat source.
- Electrical life

Use per load capability and life cycle limits so as not to cause a function failure (treat the contactor as a product with specified life and replace it when necessary). It is possible to make parts burn around the contactor once operating failure occurs. It is necessary to take layout into account and to make sure power shall be cut off within 1 second.
- Lifetime of internal gas diffusion

The contactor is sealed and filled with gas, lifetime of gas diffusion is determined by temperature in contact chamber (ambient temperature + temperature generated by contact operation). Operate only in an ambient temperature from -40 to +85 °C.
- Drive power must be greater than coil power or it will reduce performance capability.
- Avoid debris or oil contamination on the main terminals to optimize contact and avoid excess heat generation.