

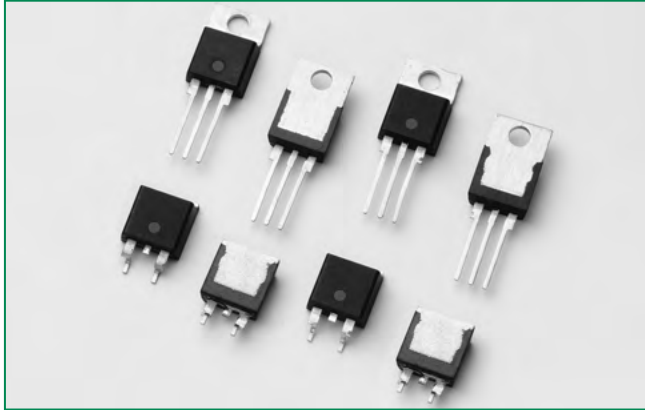

SJxx32xxA Series



Note: xx = voltage/10, x=package

Agency Recognitions

Agency	Agency File Number
	E71639

Note: L package only

Main Features

Symbol	Value	Unit
$I_{T(RMS)}$	32	A
V_{DRM}/V_{RRM}	400 or 600	V
I_{GT}	15 or 40	mA

Description

This SJxx32xxA high temperature SCR series is ideal for uni-directional switch applications such as phase control in heating, motor speed controls and AC rectifier and voltage regulator.

This SCR series offer low gate current trigger levels of 15 mA or 40 mA at approximately 1.5V.

Features & Benefits

- High junction temperature
- Voltage capability up to 600 V
- Surge capability up to 380 A at 60 Hz half cycle
- AEC-Q101 qualified
- Recognized to UL 1557 as an Electrically Isolated Semiconductor Device
- Halogen-free and ROHS compliant

Applications

Typical applications are AC rectifier, voltage regulator, AC solid-state switches, industrial power tools, exercise equipment, white goods and commercial appliances.

Schematic Symbol

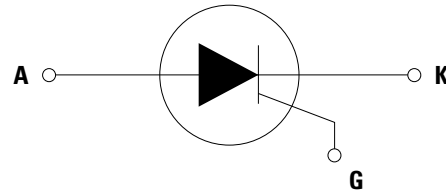

Absolute Maximum Ratings

Symbol	Parameter	Test Conditions	Value	Unit
V_{DSM}/V_{RSM}	Peak non-repetitive blocking voltage	$P_w = 100\mu s$	700	V
$I_{T(RMS)}$	RMS on-state current	SJxx32LxA $T_c = 80^\circ C$	32	A
		SJxx32RxA/SJxx32NxA $T_c = 115^\circ C$		
$I_{T(AV)}$	Average on-state current	SJxx32LxA $T_c = 80^\circ C$	20	A
		SJxx32RxA/SJxx32NxA $T_c = 115^\circ C$		
I_{TSM}	Peak non-repetitive surge current	single half cycle; $f = 50Hz$; T_J (initial) = $25^\circ C$	320	A
		single half cycle; $f = 60Hz$; T_J (initial) = $25^\circ C$	380	
I^2t	I^2t Value for fusing	$t_p = 8.3 ms$	640	A^2s
di/dt	Critical rate of rise of on-state current	$f = 60Hz$; $T_J = 150^\circ C$	150	$A/\mu s$
I_{GM}	Peak gate current	$t_p \leq 10\mu s$; $T_J = 150^\circ C$	4	A
$P_{G(AV)}$	Average gate power dissipation	$t_p \leq 10\mu s$; $T_J = 150^\circ C$	1	W
T_{stg}	Storage temperature range		-40 to 150	$^\circ C$
T_J	Operating junction temperature range		-40 to 150	$^\circ C$

Electrical Characteristics ($T_J = 25^\circ\text{C}$, unless otherwise specified)

Symbol	Test Conditions		SJxx32xA	SJxx32x2A	Unit	
I_{GT}	$V_D = 12\text{V}; R_L = 30\ \Omega$	MAX.	40	15	mA	
		MIN.	5	3		
V_{GT}		MAX.	1.5		V	
dv/dt	$V_D = V_{DRM}; \text{gate open}; T_J = 125^\circ\text{C}$	400V	MIN.	650	400	V/ μs
		600V		600	350	
	$V_D = V_{DRM}; \text{gate open}; T_J = 150^\circ\text{C}$	400V		550	-	
		600V		500	-	
	$V_D = 67\%V_{DRM}; \text{gate open}; T_J = 150^\circ\text{C}$	400V		-	300	
		600V		-	250	
V_{GD}	$V_D = V_{DRM}; R_L = 3.3\ \text{k}\Omega; T_J = 150^\circ\text{C}$	MIN.	0.2		V	
I_H	$I_T = 400\text{mA}$ (initial)	MAX.	60	50	mA	
t_q	$I_T = 2\text{A}; t_p = 50\ \mu\text{s}; dv/dt = 5\text{V}/\mu\text{s}; di/dt = -30\text{A}/\mu\text{s}$	MAX.	35		μs	
t_{gt}	$I_G = 2 \times I_{GT}; \text{PW} = 15\ \mu\text{s}; I_T = 64\text{A}$	TYP.	2		μs	

Note: xx = voltage/10, x=package

Static Characteristics

Symbol	Test Conditions		Value	Unit	
V_{TM}	$I_T = 64\text{A}; t_p = 380\ \mu\text{s}$	MAX.	1.6	V	
I_{DRM} / I_{RRM}	@ V_{DRM} / V_{RRM}	$T_J = 25^\circ\text{C}$	MAX.	10	μA
		$T_J = 125^\circ\text{C}$		2000	
		$T_J = 150^\circ\text{C}$		4000	

Thermal Resistances

Symbol	Parameter	Value	Unit
$R_{\theta(UC)}$	SJxx32LxA	1.9	$^\circ\text{C}/\text{W}$
	SJxx32RxA/SJxx32NxA	0.8	

Note: xx = voltage, x = sensitivity & type

Figure 1: Normalized DC Gate Trigger Current vs. Junction Temperature

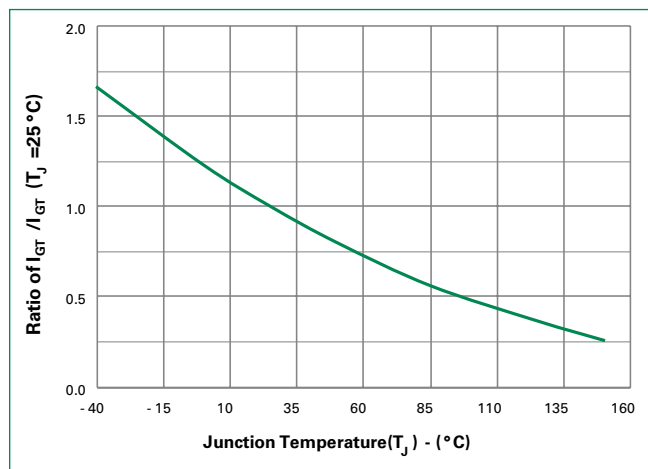

Figure 2: Normalized DC Gate Trigger Voltage vs. Junction Temperature

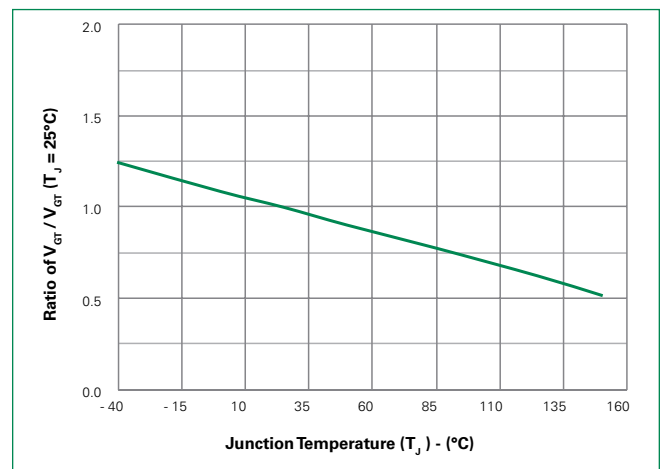

Figure 3: Normalized DC Holding Current vs. Junction Temperature

Figure 4: On-State Current vs. On-State Voltage (Typical)

Figure 5: Power Dissipation (Typical) vs. RMS On-State Current

Figure 6: Maximum Allowable Case Temperature vs. RMS On-State Current

Figure 7: Maximum Allowable Case Temperature vs. Average On-State Current

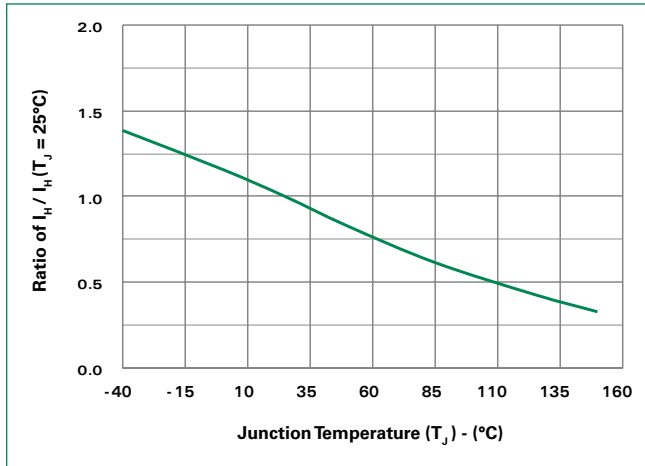
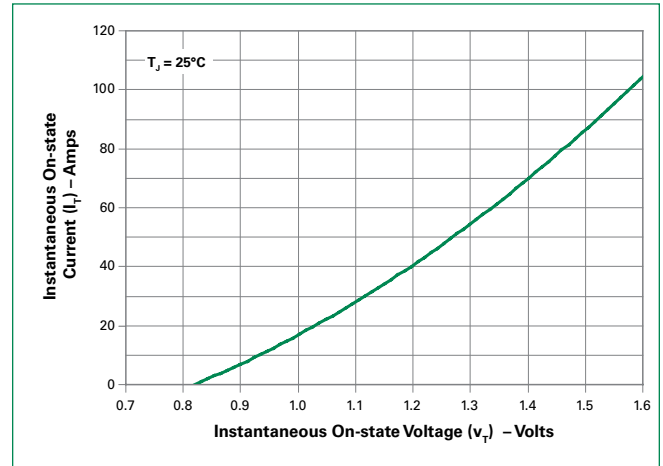
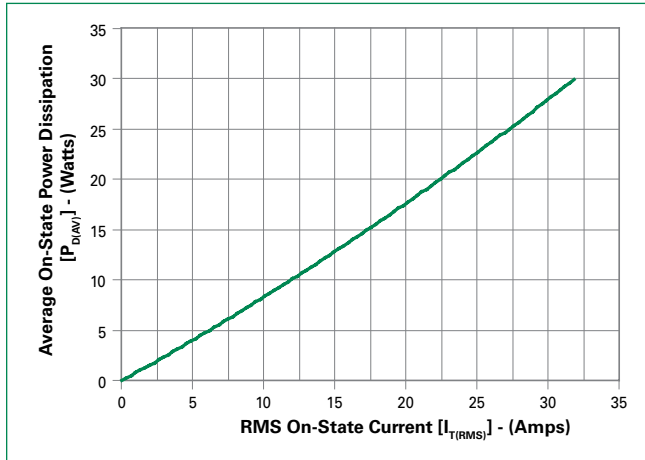
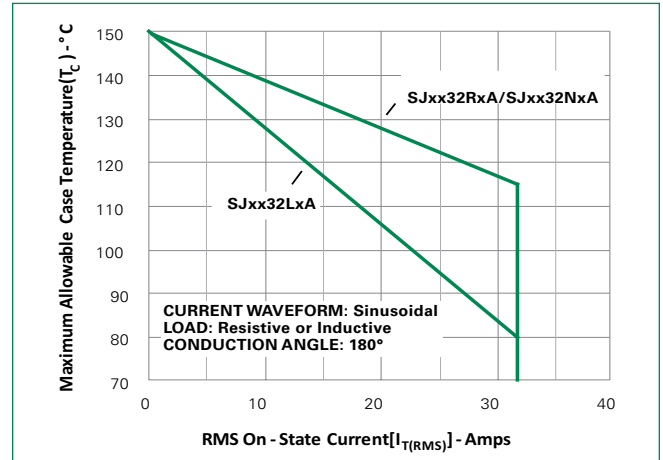
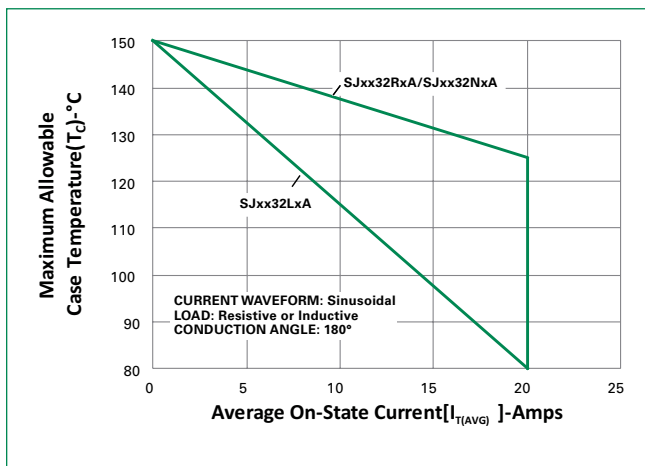
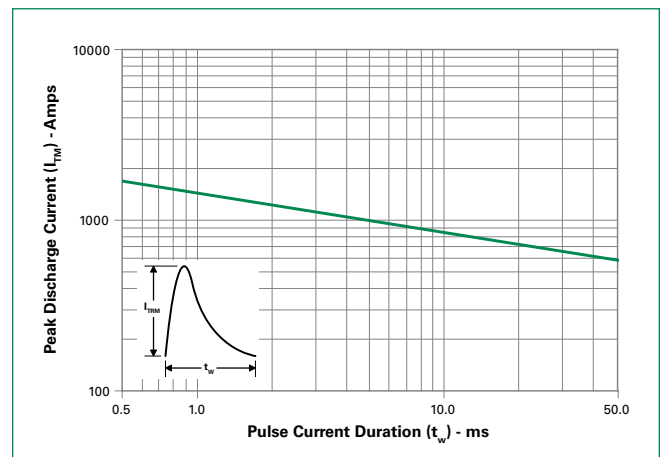
Figure 8: Peak Capacitor Discharge Current

Figure 9: Peak Capacitor Discharge Current Derating

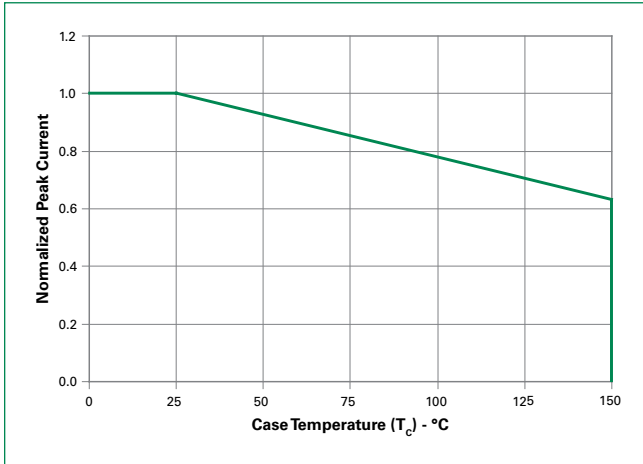
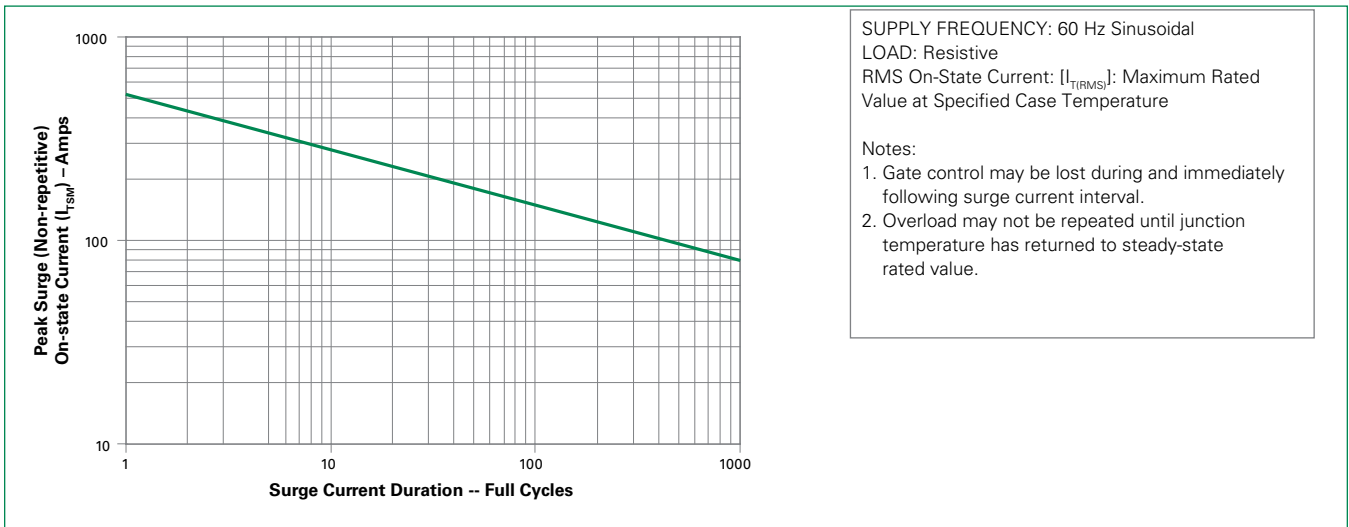
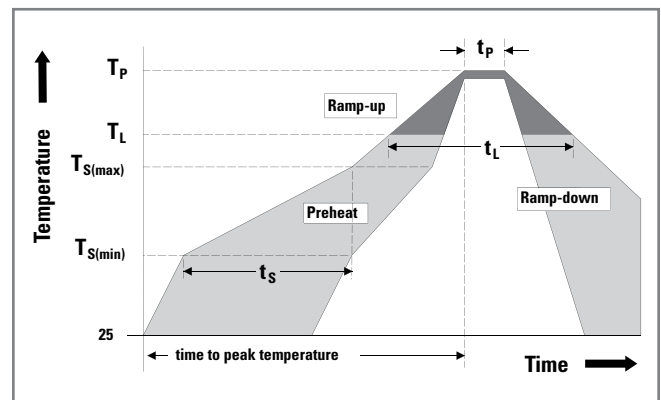

Figure 10: Surge Peak On-State Current vs. Number of Cycles



Soldering Parameters

Reflow Condition		Pb – Free assembly
Pre Heat	- Temperature Min ($T_{s(min)}$)	150°C
	- Temperature Max ($T_{s(max)}$)	200°C
	- Time (min to max) (t_s)	60 – 180 secs
Average ramp up rate (Liquidus Temp) (T_L) to peak		5°C/second max
$T_{s(max)}$ to T_L - Ramp-up Rate		5°C/second max
Reflow	- Temperature (T_L) (Liquidus)	217°C
	- Time (t_l)	60 – 150 seconds
Peak Temperature (T_p)		260 ^{+0/-5} °C
Time within 5°C of actual peak Temperature (t_p)		20 – 40 seconds
Ramp-down Rate		5°C/second max
Time 25°C to peak Temperature (T_p)		8 minutes Max.
Do not exceed		280°C



Physical Specifications

Terminal Finish	100% Matte Tin-plated
Body Material	UL Recognized compound meeting flammability rating V-0
Lead Material	Copper Alloy

Design Considerations

Careful selection of the correct component for the application's operating parameters and environment will go a long way toward extending the operating life of the Thyristor. Good design practice should limit the maximum continuous current through the main terminals to 75% of the component rating. Other ways to ensure long life for a power discrete semiconductor are proper heat sinking and selection of voltage ratings for worst case conditions. Overheating, overvoltage (including dv/dt), and surge currents are the main killers of semiconductors. Correct mounting, soldering, and forming of the leads also help protect against component damage.

Environmental Specifications

Test	Specifications and Conditions
AC Blocking	MIL-STD-750, M-1040, Cond A Applied Peak AC voltage @ 150°C for 1008 hours
Temperature Cycling	MIL-STD-750, M-1051, 1000 cycles; -55°C to +150°C; 15-min dwell-time
Temperature/Humidity	EIA / JEDEC, JESD22-A101 1008 hours; 160V - DC: 85°C; 85% rel humidity
Resistance to Solder Heat	MIL-STD-750 Method 2031
Solderability	ANSI/J-STD-002, category 3, Test A
Lead Bend	MIL-STD-750, M-2036 Cond E
Moisture Sensitivity Level	Level 1, JEDEC-J-STD-020D
UHASt	JESD22A-118,96hrs, 130oC/85%RH
IOL	MIL-STD-750 Method 1037

Dimensions — TO-220AB (L-Package) — Isolated Mounting Tab

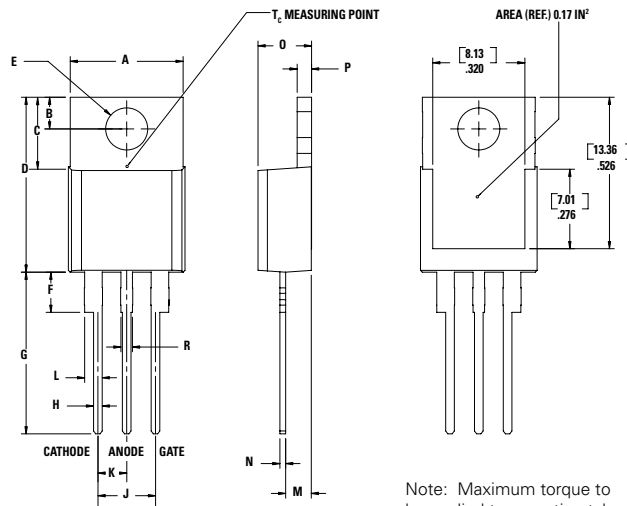

Note: Maximum torque to be applied to mounting tab is 8 in-lbs. (0.904 Nm).

Dimension	Inches		Millimeters	
	Min	Max	Min	Max
A	0.380	0.420	9.65	10.67
B	0.105	0.115	2.67	2.92
C	0.230	0.250	5.84	6.35
D	0.590	0.620	14.99	15.75
E	0.142	0.147	3.61	3.73
F	0.110	0.130	2.79	3.30
G	0.540	0.575	13.72	14.61
H	0.025	0.035	0.64	0.89
J	0.195	0.205	4.95	5.21
K	0.095	0.105	2.41	2.67
L	0.060	0.075	1.52	1.91
M	0.085	0.095	2.16	2.41
N	0.018	0.024	0.46	0.61
O	0.178	0.188	4.52	4.78
P	0.045	0.060	1.14	1.52
R	0.038	0.048	0.97	1.22

Dimensions – TO-220AB (R-Package) – Non-Isolated Mounting Tab Common with Center Lead

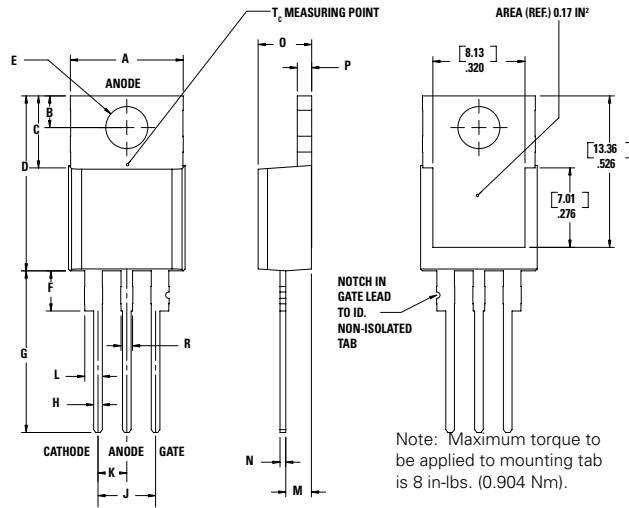

Dimension	Inches		Millimeters	
	Min	Max	Min	Max
A	0.380	0.420	9.65	10.67
B	0.105	0.115	2.67	2.92
C	0.230	0.250	5.84	6.35
D	0.590	0.620	14.99	15.75
E	0.142	0.147	3.61	3.73
F	0.110	0.130	2.79	3.30
G	0.540	0.575	13.72	14.61
H	0.025	0.035	0.64	0.89
J	0.195	0.205	4.95	5.21
K	0.095	0.105	2.41	2.67
L	0.060	0.075	1.52	1.91
M	0.085	0.095	2.16	2.41
N	0.018	0.024	0.46	0.61
O	0.178	0.188	4.52	4.78
P	0.045	0.060	1.14	1.52
R	0.038	0.048	0.97	1.22

Dimensions – TO- 263 (N-package) – D²-Pak Surface Mount

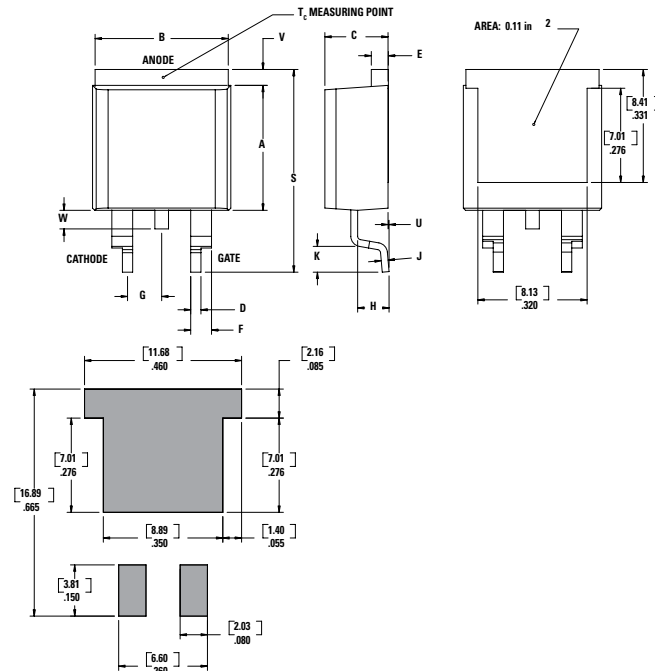

Dimension	Inches		Millimeters	
	Min	Max	Min	Max
A	0.360	0.370	9.14	9.40
B	0.380	0.420	9.65	10.67
C	0.178	0.188	4.52	4.78
D	0.025	0.035	0.63	0.89
E	0.048	0.055	1.22	1.40
F	0.060	0.075	1.52	1.91
G	0.095	0.105	2.41	2.67
H	0.083	0.093	2.11	2.36
J	0.018	0.024	0.46	0.61
K	0.090	0.110	2.29	2.79
S	0.590	0.625	14.99	15.87
V	0.035	0.045	0.89	1.14
U	0.002	0.010	0.05	0.25
W	0.040	0.070	1.02	1.78

Part Numbering System

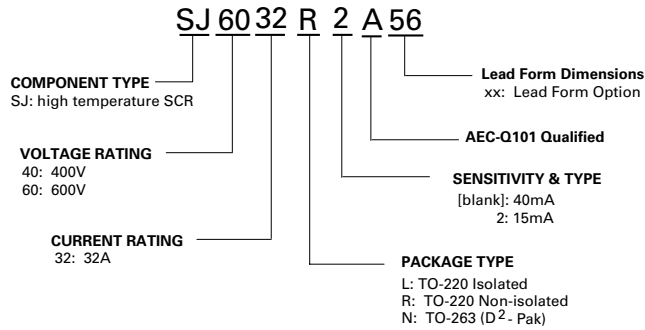

Part Marking System

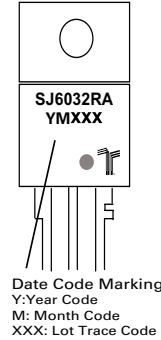

Product Selector

Part Number	Voltage		Gate Sensitivity	Type	Package
	400V	600V			
SJxx32LA	X	X	40mA	Standard SCR	TO-220L
SJxx32RA	X	X	40mA	Standard SCR	TO-220R
SJxx32NA	X	X	40mA	Standard SCR	TO-263
SJxx32L2A	X	X	15mA	Standard SCR	TO-220L
SJxx32R2A	X	X	15mA	Standard SCR	TO-220R
SJxx32N2A	X	X	15mA	Standard SCR	TO-263

Note: xx = Voltage/10

Packing Options

Part Number	Marking	Weight	Packing Mode	Base Quantity
SJxx32LATP	SJxx32LA	2.2g	Tube	1000 (50 per tube)
SJxx32RATP	SJxx32RA	2.2g	Tube	1000 (50 per tube)
SJxx32NATP	SJxx32NA	1.6g	Tube	1000 (50 per tube)
SJxx32NARP	SJxx32NA	1.6g	Embossed Carrier	500
SJxx32L2ATP	SJxx32L2A	2.2g	Tube	1000 (50 per tube)
SJxx32R2ATP	SJxx32R2A	2.2g	Tube	1000 (50 per tube)
SJxx32N2ARP	SJxx32N2A	1.6g	Embossed Carrier	500
SJxx32N2ATP	SJxx32N2A	1.6g	Tube	1000 (50 per tube)

Note: xx = Voltage/10

Reel Pack (RP) for TO-263 Embossed Carrier Specifications

Meets all EIA-481-2 Standards

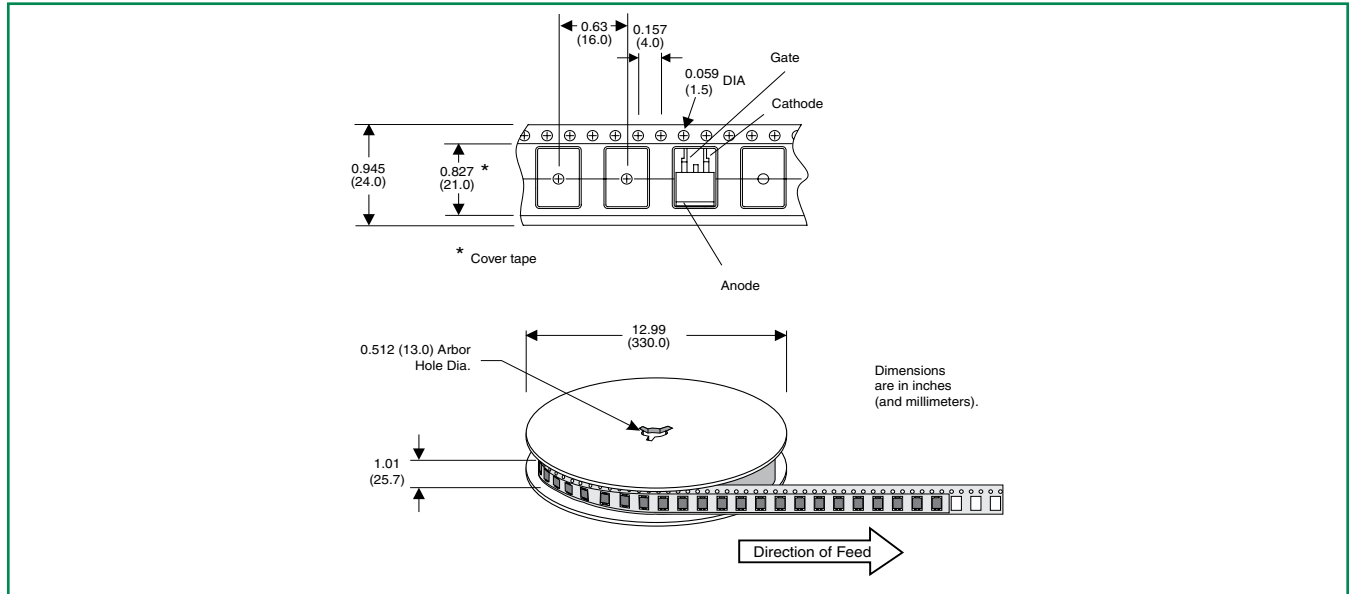

Disclaimer Notice - Information furnished is believed to be accurate and reliable. However, users should independently evaluate the suitability of and test each product selected for their own applications. Littelfuse products are not designed for, and may not be used in, all applications.

Read complete Disclaimer Notice at <http://www.littelfuse.com/disclaimer-electronics>.