

4

3

2

1

NOTES:

- 1. ALL STUDS TO BE STAINLESS STEEL WITH ROLLED THREADS
- 2. ALL BUS BARS TO BE TIN PLATED COPPER
- 3. WEIGHT EST 350 grams
- 4. RECOMMENDED TORQUE VALUES:
  - 1. MEGA FUSES - 15 N-m ±1.36 (11 ft-lb ±1)
  - 2. TERMINALS - 28.5 N-m ±1.36 (21 ft-lb ±1)
- 7. RECOMMENDED HARDWARE (TO BE INSTALLED AT LESS THAN 300 RPM);
  - 1. M10x1.50 18-8 STAINLESS STEEL
  - 2. M8x1.25 18-8 STAINLESS STEEL
- 8. LOCATION OF GORE VENT
- 9. MATERIAL:
  - HOUSING: GLASS FILLED NYLON 94V-0 COVER: GLASS FILLED PC 94V-0
- 10. MIN/MAX TEMPERATURE RATING: OPERATIONAL: -50C~105C NON-OPERATIONAL: -55C~125C
- 11. MAX CURRENT INPUT: 600 AMPS
- 12. MAX ASSEMBLY TORQUE (PRODUCT TO MOUNTING SURFACE): 30 N-m

REVISIONS				
ZONE	REV.	DESCRIPTION	DATE	APPROVED
	A	PER EC#515478: INITIAL RELEASE	2/19/2016	J. LIU

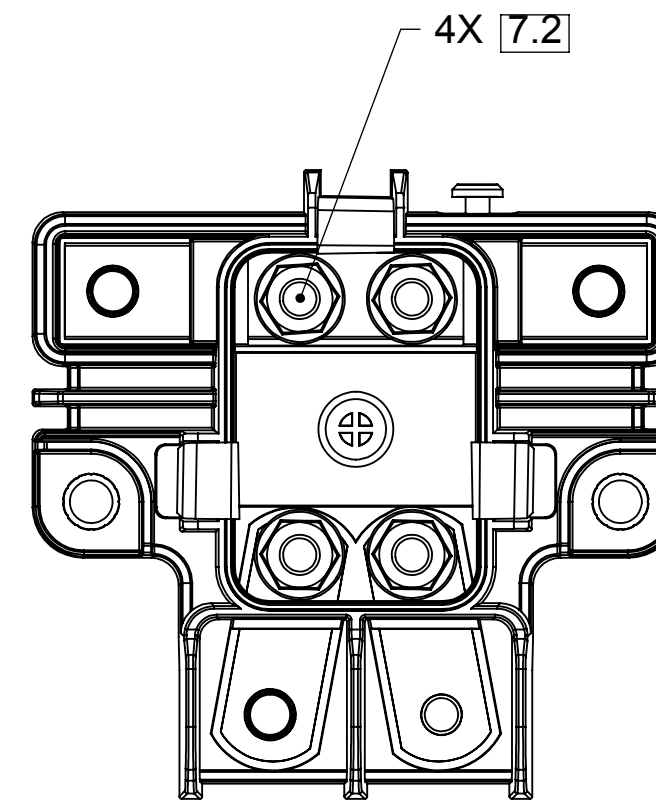
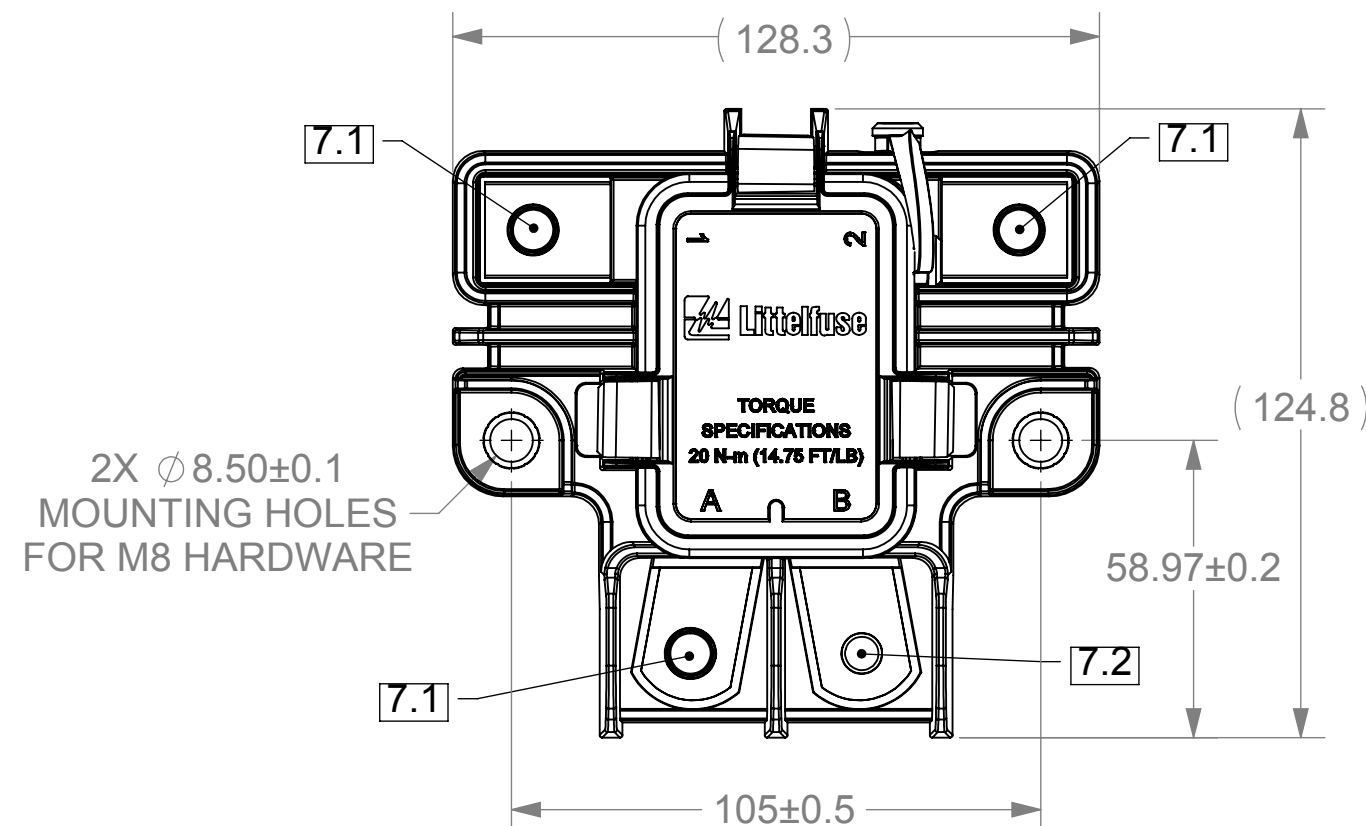
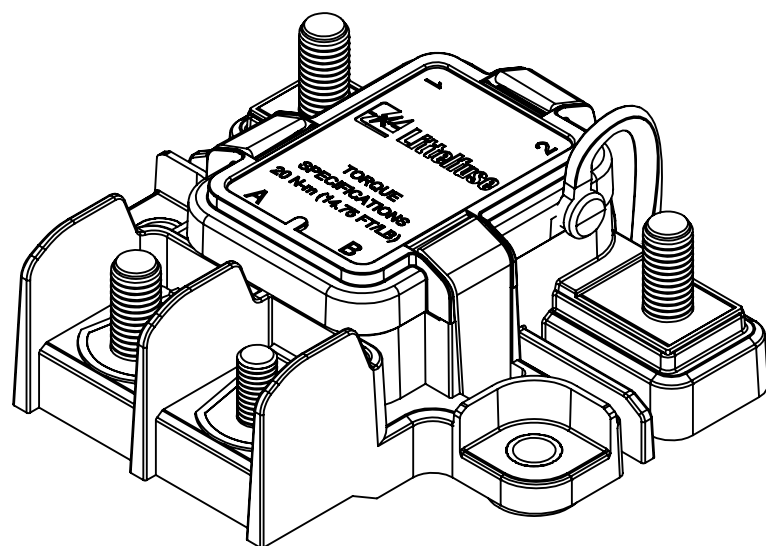

FUSE COVER REMOVED

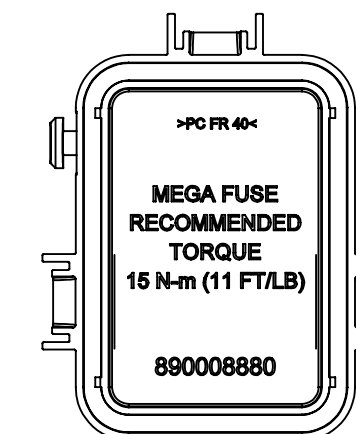

INSIDE FUSE COVER

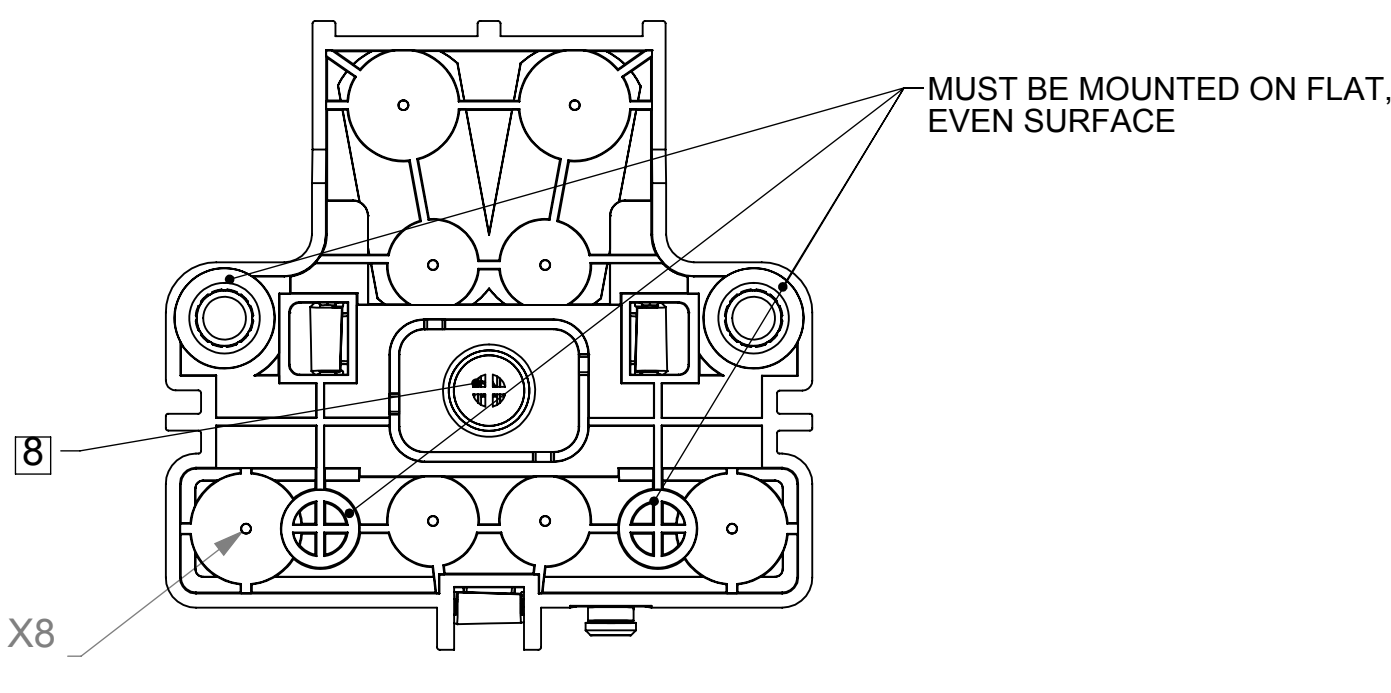
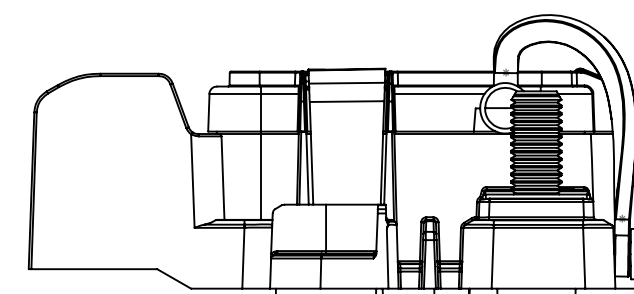
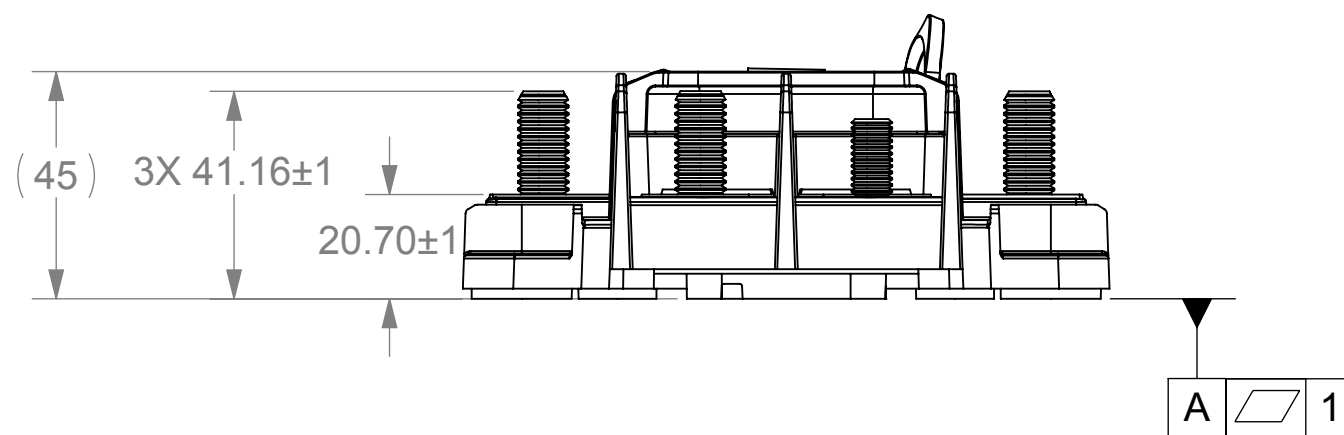
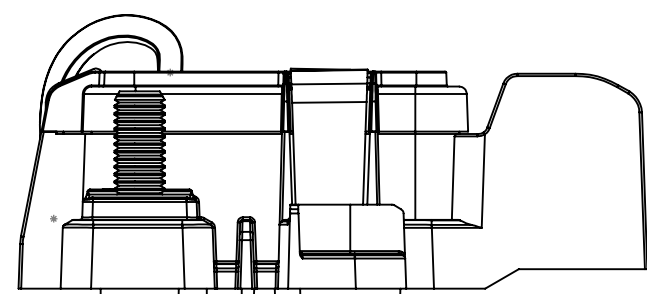

DIMENSIONS ARE IN MM.  
 DIMENSIONS AND TOLERANCES ARE DEFINED ACCORDING TO ANSI / ASME Y14.5M-1994  
 THIS DRAWING AND THE INFORMATION CONTAINED WITHIN IT ARE CONFIDENTIAL AND MAY NOT BE COPIED OR DISCLOSED WITHOUT THE WRITTEN PERMISSION OF LITTELFUSE.

NAME	DATE
DRAWN J. LIU	2/19/2016
CHECKED -	-
-	-
-	-
-	-



PDM 2 Position - Market

SIZE	DWG. NO.	REV.
C	OL-880195400	A

4

3

2

1