

Revision Control Record

Rev.	Description of Change	ECN No.	Date
G	ADD NOTE 2	04343	09/22/04
H	CONVERT TO 3D CAD	09175	03/04/09

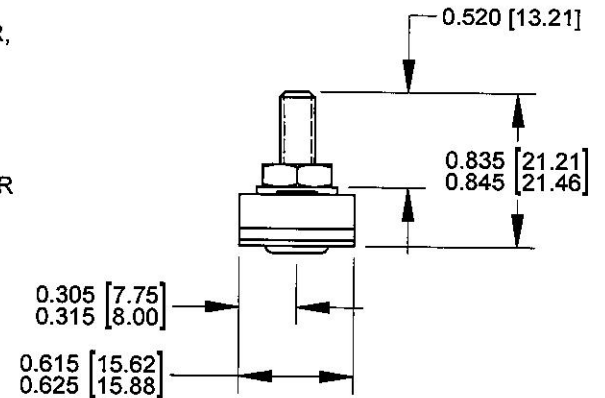
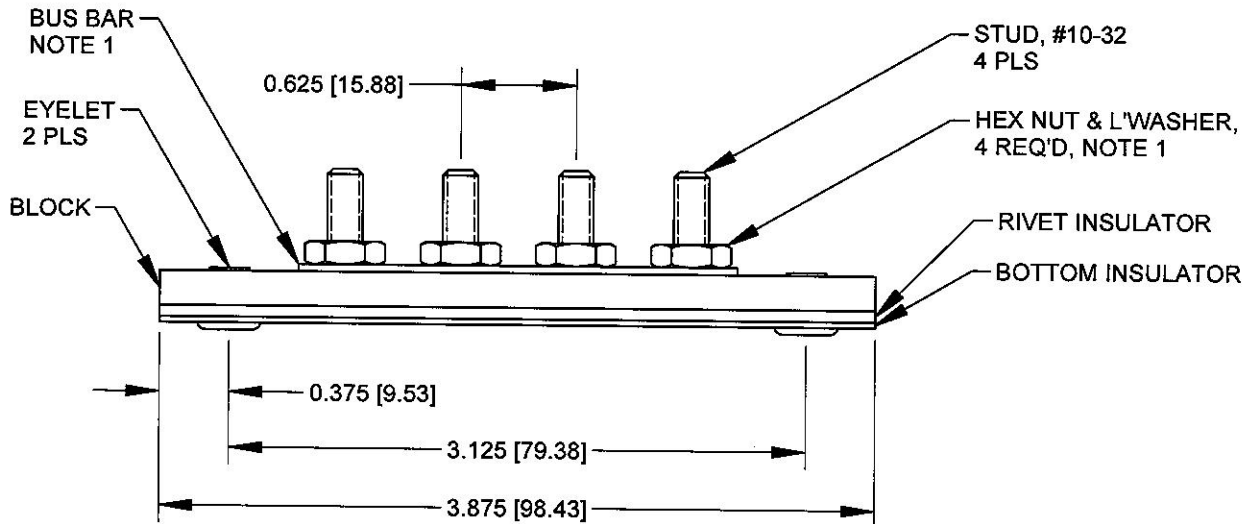
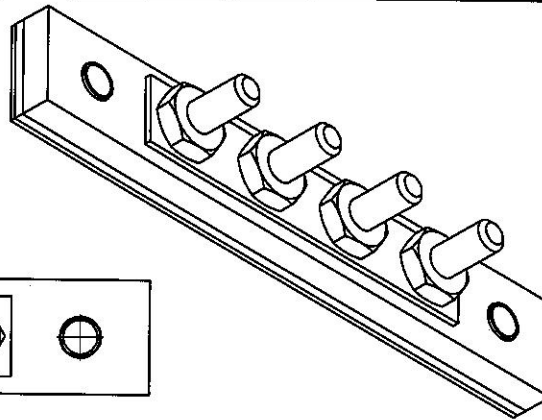
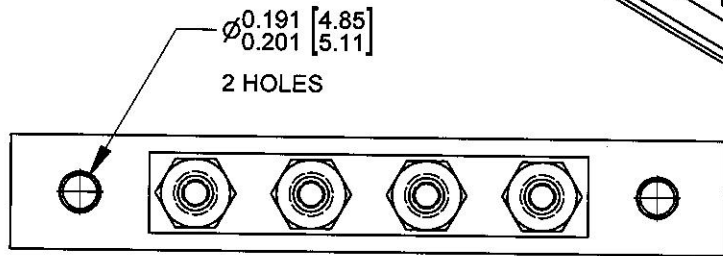

NOTES

- 1. PARTS MAYBE ASSEMBLED OR SUPPLIED IN A BAG
- 2. ALL DIMENSIONS ARE REFERENCE

Tolerances Unless otherwise specifically noted, the following are default tolerances;

2-places **3-places** **Angular**
 +/- 0.02" +/- 0.005" +/- 1°

Metric: Shown in [] refers to equivalent English Dim Tol

"REF." or an Asterisk (*) = Non-Toleranced Reference Dimension, shown for clarification purposes only.

NOTE: All tolerances are Non-Cumulative.

PROPRIETARY INFORMATION

This Engineering Drawing, and the information contained herein, is proprietary to Cole Hersee Company and may not be disclosed, re-produced, or in any other way transferred or communicated to any other party without the express written consent of an authorized representative of Cole Hersee Company.

Special Characteristics:

- Critical Characteristic, relating to Safety and/or Regulatory Compliance
- Significant Characteristic relating to Process Control
- Control Dimension relating to Form - Fit - Function as defined by Cole Hersee Company and/or the Customer



Cole Hersee Co.

20 Old Colony Ave., South Boston, MA, 02127
 Phn: 617-268-2100 Web: www.colehersee.com

Description: TERMINAL BLOCK 4P

Drawing / Part No.: 46206-04

Current Rev. H

FORM CHT-6 (2/07)

Used On or Ref.: **4721-P4 WITH BUS BAR**

Scale: **1:1**

Drawn By: **FCW**

Date Drawn: **03/08/68**

Pg. 1 of 1