

REVISION		
REV	DATE	DESCRIPTION
A	8/9/22	525548GCP - RELEASE MRY

$\varnothing 10.3 \pm .10$
 $[\varnothing .406 \pm .004]$

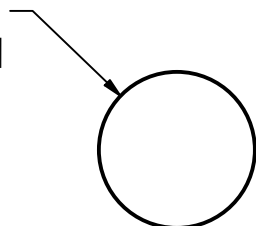

APPROXIMATE SHIPPING WEIGHT: 10 FUSES / 0.17 LBS.

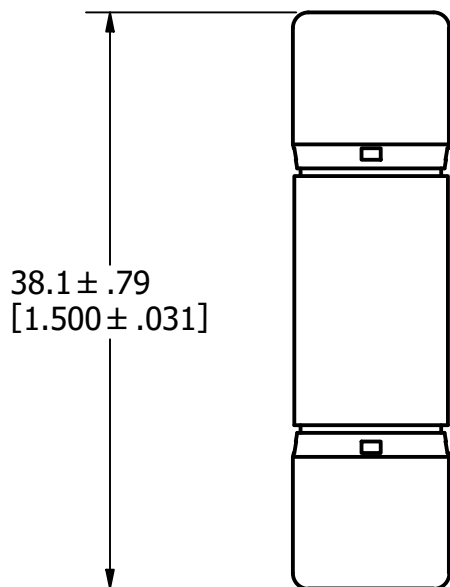

1	NO	COMPONENT NO	DESCRIPTION	QTY/M	U/M
BILL OF MATERIAL					
<S>	CRITICAL CHARACTERISTIC FOR PART SAFETY/COMPLIANCE				
●	DENOTES CRITICAL CHARACTERISTICS.				
CPK	DENOTES CPK DIMENSIONS, -MINIMUM CPK VALUE				
⊠	DENOTES A CHARACTERISTIC THAT PROVIDES AN INDICATION OF PROCESS PERFORMANCE. PROCEDURE FOR MEASUREMENT AND TRACKING TO BE DEFINED IN LITTELFUSE INSPECTION INSTRUCTIONS.				
CP	DENOTES CP DIMENSIONS, -MINIMUM CP VALUE MUST BE WITHIN THE DIMENSIONAL LIMITATIONS SHOWN ON DRAWING AND INITIALLY LOCATED TO ALLOW FOR MAXIMUM TOOL LIFE.				A
MATL SPEC			FINISH		
DRW	DATE	SCALE	FINISH GOOD WT		
JMoler	8/9/2022	NTS	GRAMS/PIECE		
UNLESS OTHERWISE SPECIFIED, DIMENSIONS ARE IN MILLIMETERS, DIMENSIONS IN BRACKETS [] ARE INCHES DIMENSIONING AND DO NOT INCLUDE PLATING. TOLERANCING TO BE INTERPRETED IN ACCORDANCE WITH ANSI Y14.5M-1994					
3RD ANGLE PROJECTION					
TITLE					
593S 1/10-30A OUTLINE					
Littelfuse CHICAGO, ILLINOIS 60631			REVISION	DRWG NO.	SHEET 1 OF 1
			A	OL-0593030-S	