

PART NUMBER	UPC CODE
LDM3SAB1	07945831090

REVISION		
REV	DATE	DESCRIPTION
A	5/15/23	526513GCP - RELEASE MRY

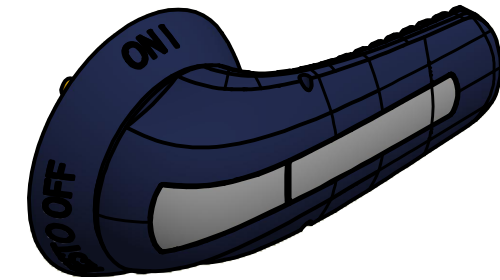
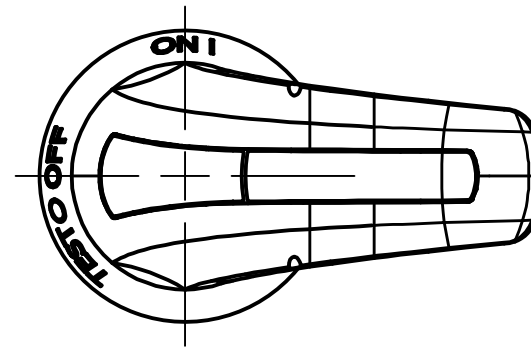
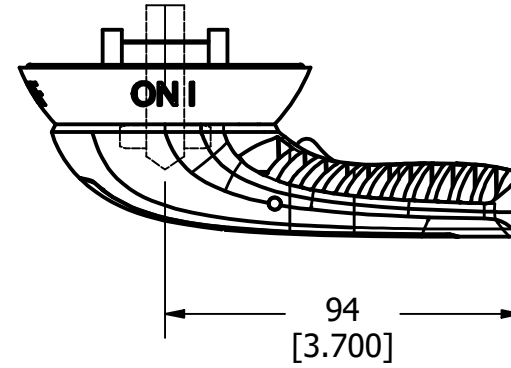
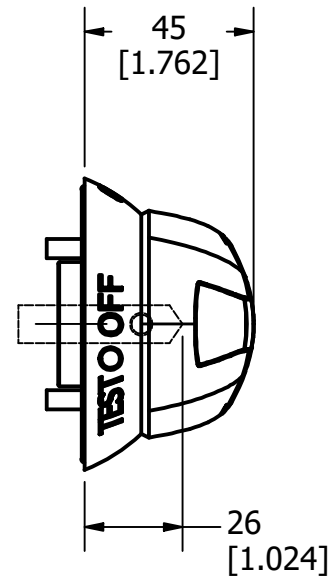

1	NO	COMPONENT NO	DESCRIPTION	QTY/M	U/M
<b>BILL OF MATERIAL</b>					
<S>	CRITICAL CHARACTERISTIC FOR PART SAFETY/COMPLIANCE				
●	DENOTES CRITICAL CHARACTERISTICS.				
CPK	DENOTES CPK DIMENSIONS, -MINIMUM CPK VALUE				
⊠	DENOTES A CHARACTERISTIC THAT PROVIDES AN INDICATION OF PROCESS PERFORMANCE. PROCEDURE FOR MEASUREMENT AND TRACKING TO BE DEFINED IN LITTELFUSE INSPECTION INSTRUCTIONS.				
CP	DENOTES CP DIMENSIONS, -MINIMUM CP VALUE MUST BE WITHIN THE DIMENSIONAL LIMITATIONS SHOWN ON DRAWING AND INITIALLY LOCATED TO ALLOW FOR MAXIMUM TOOL LIFE. <span style="float: right; border: 1px solid black; padding: 2px;"><b>B</b></span>				
MATL SPEC			FINISH		
DRW myork	DATE 12/16/2022	SCALE NTS	FINISH GOOD WT GRAMS/PIECE		
UNLESS OTHERWISE SPECIFIED, DIMENSIONS ARE IN MILLIMETERS, DIMENSIONS IN BRACKETS [ ] ARE INCHES DIMENSIONING AND DO NOT INCLUDE PLATING. TOLERANCING TO BE INTERPRETED IN ACCORDANCE WITH ANSI Y14.5M-1994					
3RD ANGLE PROJECTION					
<b>TITLE</b> EXTERNAL HANDLE ON-OFF-TEST 30-60A OUTLINE					
 CHICAGO, ILLINOIS 60631			REVISION <b>A</b>	DRWG NO. <b>OL-LDM3SAB1</b>	SHEET 1 OF 1