

PART NUMBER	UPC CODE
LM30603DJ	07945831077

REVISION		DESCRIPTION
REV	DATE	
A	5/4/23	526430GCP - RELEASE PER EM3380 MRY

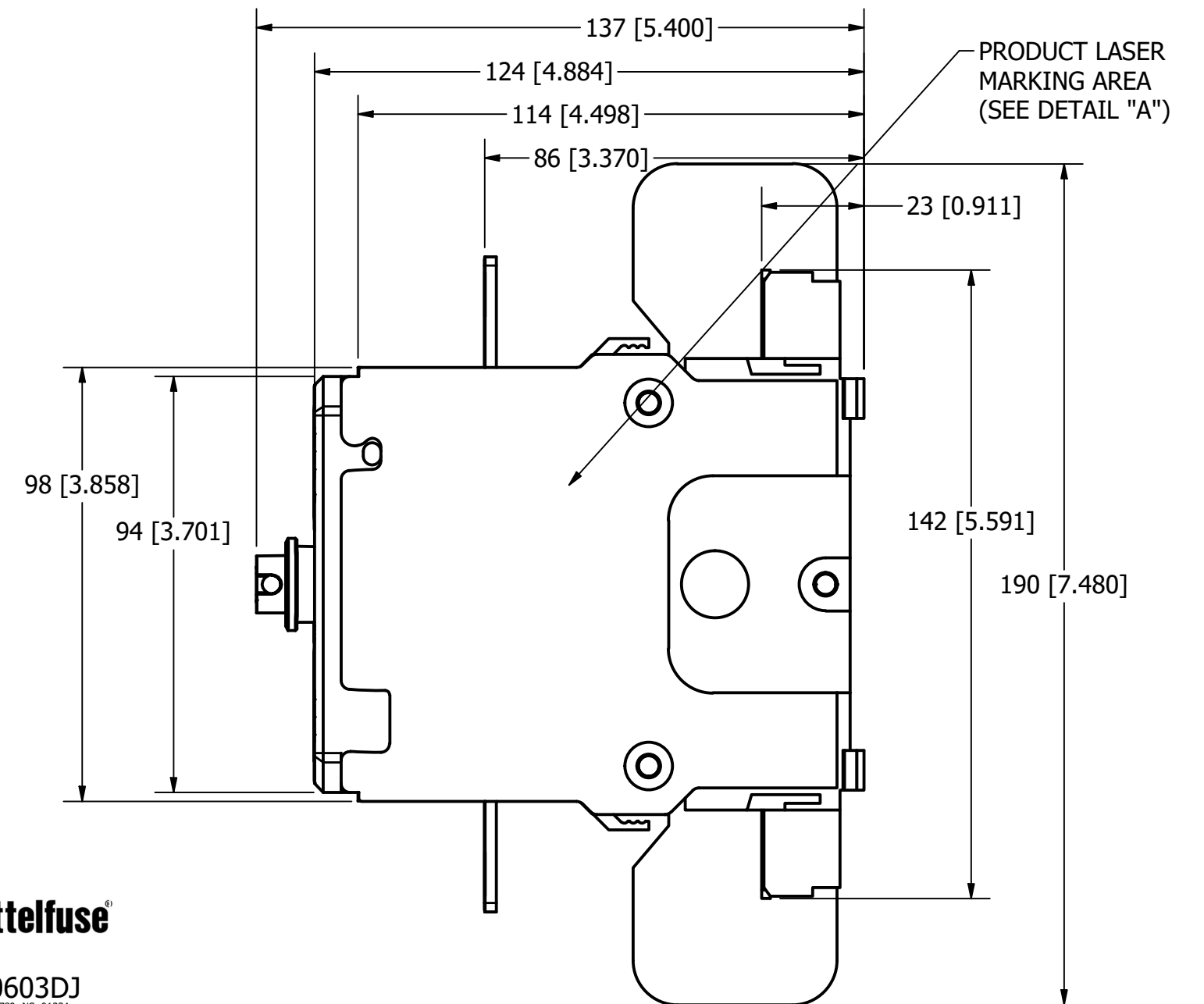

LM30603DJ
L: 0123456789; NS: 01234

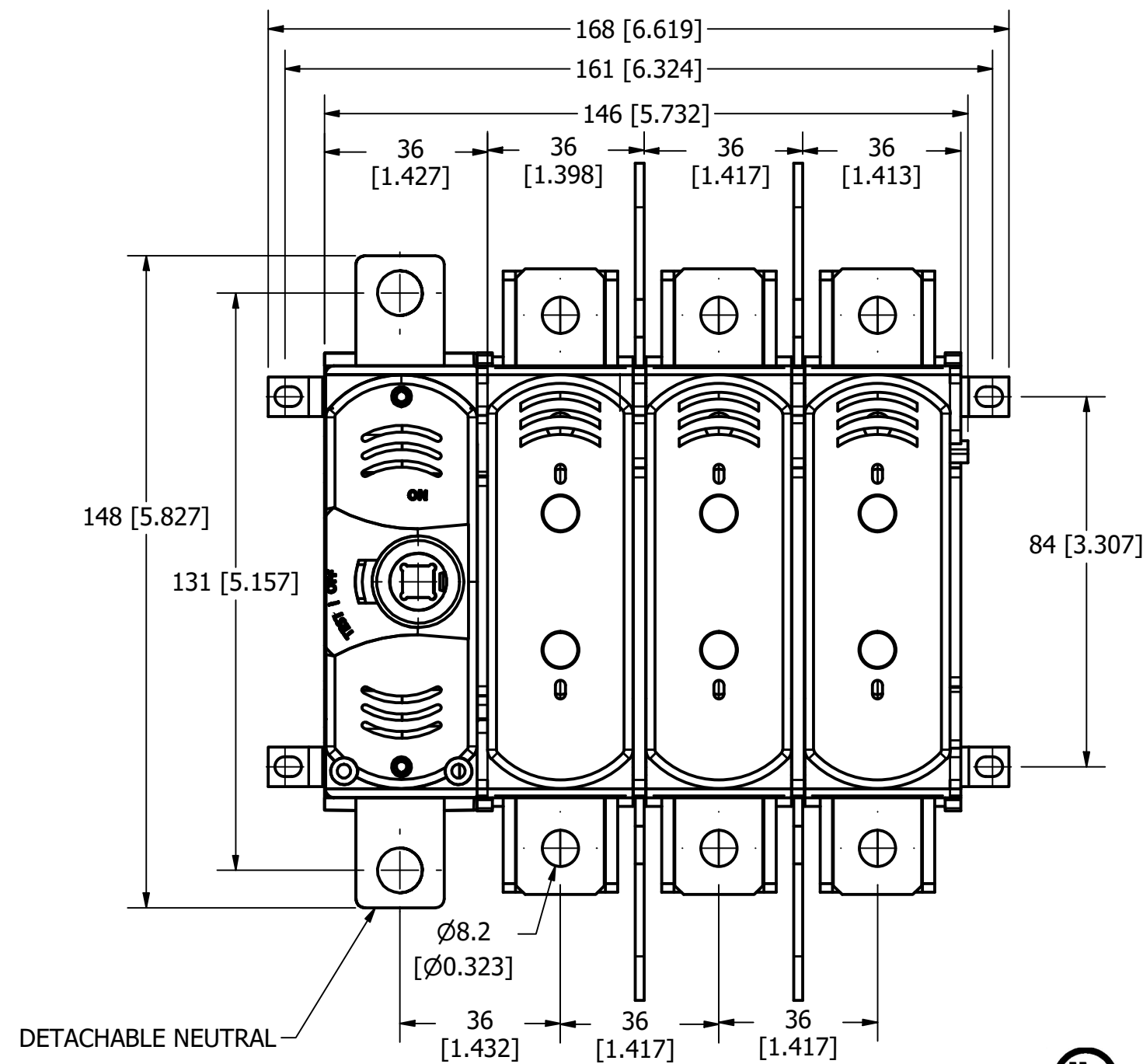
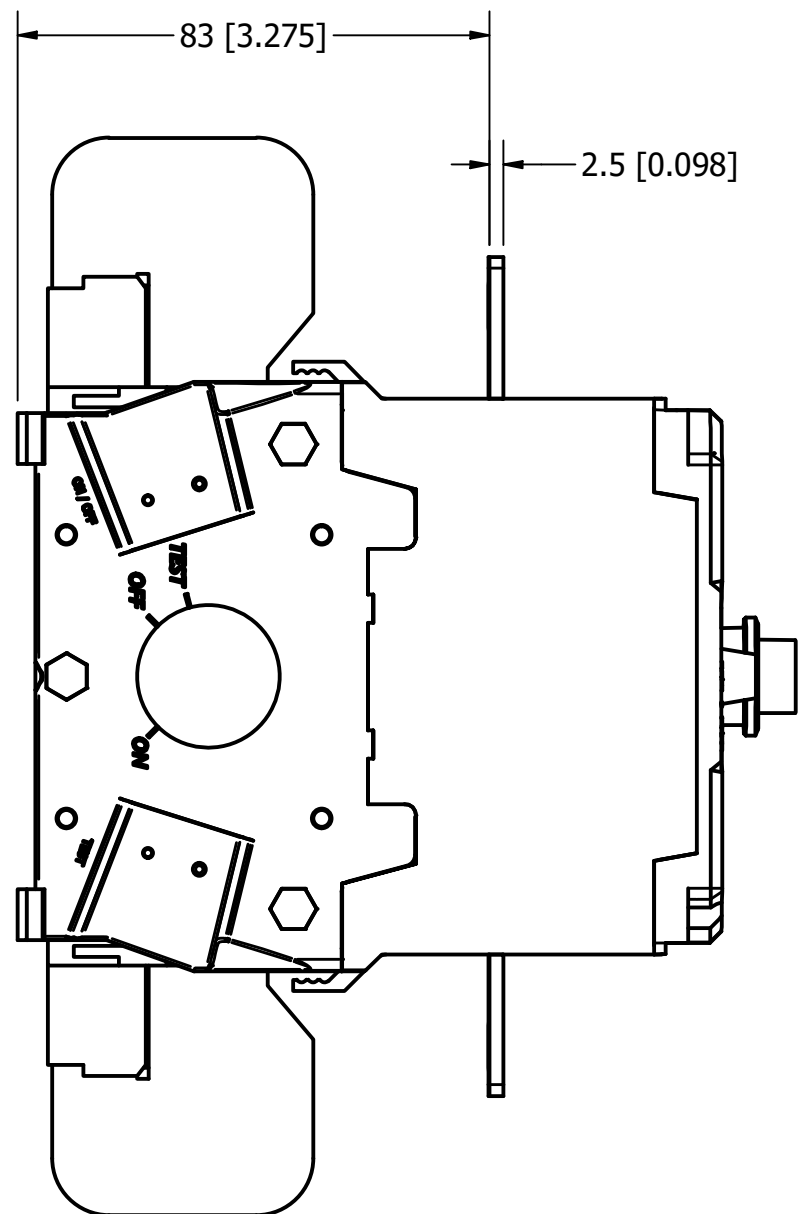
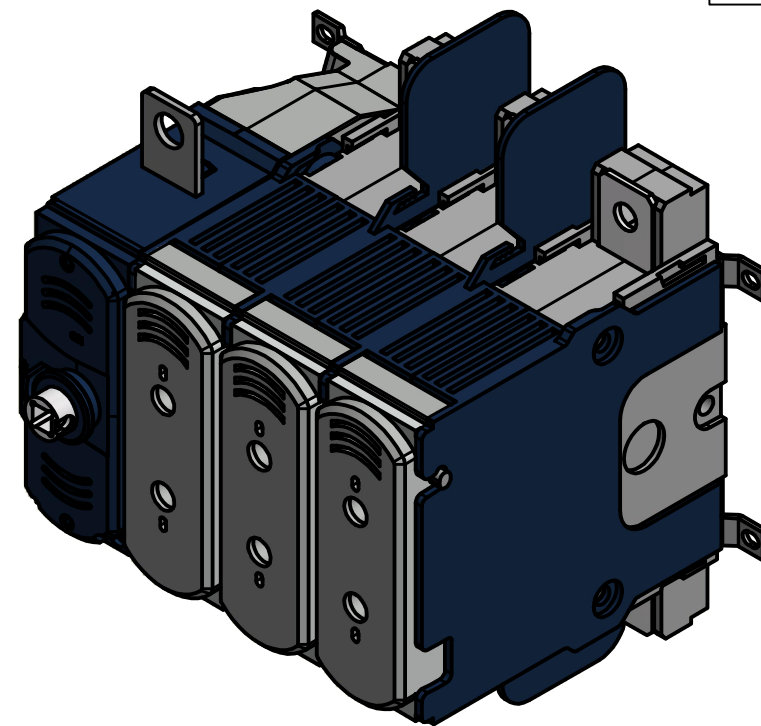
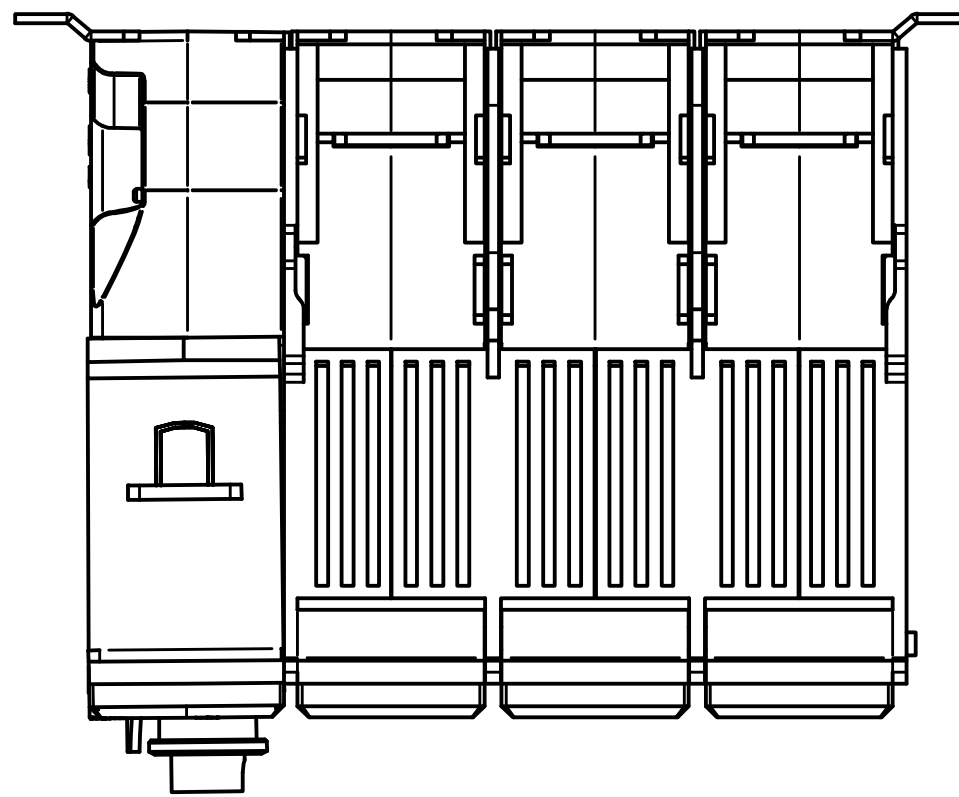

UL 98
600Vac 60A 50/60Hz
General purpose switch
Use Cu wire only
75°C 6-2/0 AWG Wire
Terminal Torque 53 LB.IN.
With KIT Terminal Lugs LDM3TLU01
Motor-Circuit Switch

3 Ø	Vac	240	480	600
MAX	HP	15	30	50
STD	HP	7.5	15	15

Suitable for use on a circuit capable of delivering not more than 200kA R.M.S symmetrical, 600V max.
Use class J fuses.

Max. fuse size **60A**

The starting current of motors of more than the standard horsepower ratings may require the use of fuses with appropriate time-delay characteristics.

Continuous load current not to exceed 80 percent of the rating of the fuses employed in other than motor circuits.

Use accessories according to instructions:
45672010

MADE IN SPAIN

DETAIL "A"
SIDE PRINTING

1	NO	COMPONENT NO	DESCRIPTION	QTY/M	U/M
BILL OF MATERIAL					
<S>	CRITICAL CHARACTERISTIC FOR PART SAFETY/COMPLIANCE				
●	DENOTES CRITICAL CHARACTERISTICS.				
CPK	DENOTES CPK DIMENSIONS, -MINIMUM CPK VALUE				
(ST)	DENOTES A CHARACTERISTIC THAT PROVIDES AN INDICATION OF PROCESS PERFORMANCE. PROCEDURE FOR MEASUREMENT AND TRACKING TO BE DEFINED IN LITTELFUSE INSPECTION INSTRUCTIONS.				
CP	DENOTES CP DIMENSIONS, -MINIMUM CP VALUE MUST BE WITHIN THE DIMENSIONAL LIMITATIONS SHOWN ON DRAWING AND INITIALLY LOCATED TO ALLOW FOR MAXIMUM TOOL LIFE.				
MATL SPEC			FINISH		
DRW	myork	DATE	1/5/2023	SCALE	NTS
			FINISH GOOD WT		
			GRAMS/PIECE		
UNLESS OTHERWISE SPECIFIED, DIMENSIONS ARE IN MILLIMETERS, DIMENSIONS IN BRACKETS [] ARE INCHES DIMENSIONING AND DO NOT INCLUDE PLATING. TOLERANCING TO BE INTERPRETED IN ACCORDANCE WITH ANSI Y14.5M-1994					
3RD ANGLE PROJECTION					
TITLE CLASS J 60A DISCONNECT 3P WITH DETACHABLE NEUTRAL OUTLINE					
Littelfuse® CHICAGO, ILLINOIS 60631			REVISION	DRWG NO.	SHEET 1 OF 1
			A	OL-LM30603DJ	