

LTR	DATE	REVISION	CHK	APD
A	05/Jan/18	518616GCC NEW RELEASED FYUE		
B	30/Mar/18	519070ECC-UPDATE INPUT CURRENT FYUE		
C	6/Nov/2020	523004ECC-CORRECT CIRCUIT DIAGRAM ERROR FYUE		

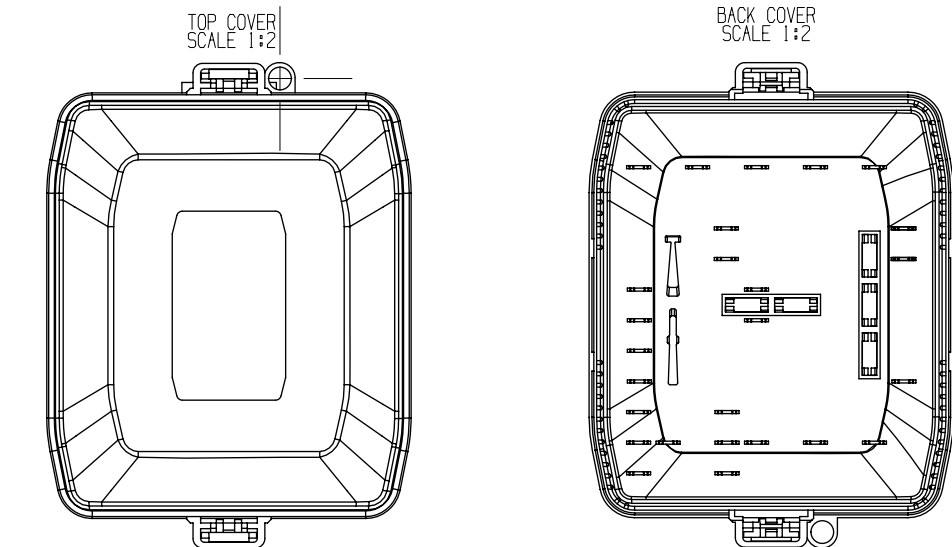

CONNECTOR: TYCO 1-1670901-1
 TERMINAL: 1-968882-1 (WIRE SIZE: 0.35mm²)
 1-968855-1 (WIRE SIZE: 0.5-1.0mm²)
 1-968857-1 (WIRE SIZE: 1.0-2.5mm²)
 1-1719506-1 (WIRE SIZE: AWG12 TXL)
 SEAL: 828904-1 (WIRE O.D.: 1.2-2.1mm)
 828905-1 (WIRE O.D.: 2.2-3.0mm, 3.2mm)
 CAVITY PLUG: 828922-1

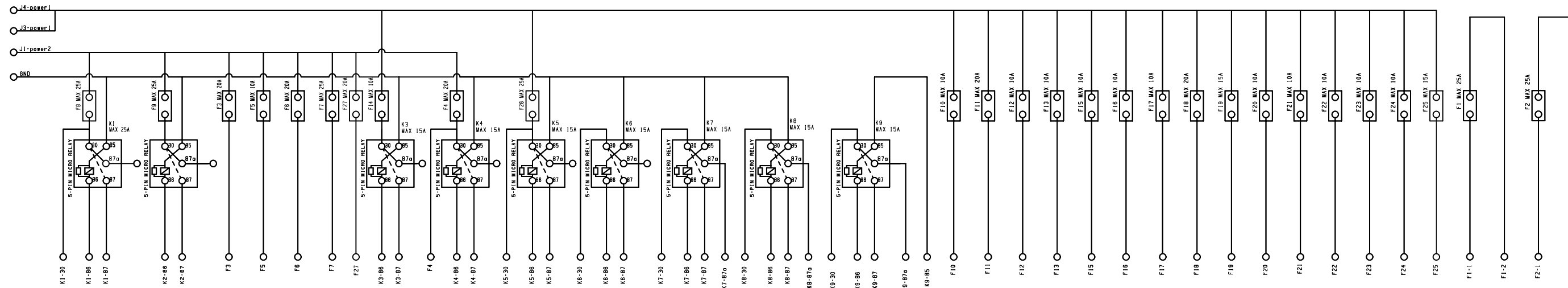
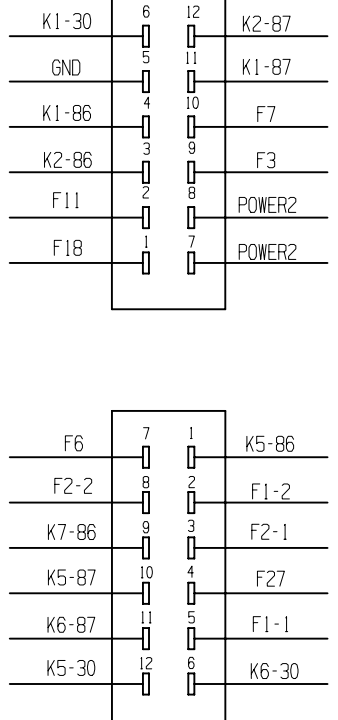

CONNECTOR: TYCO 1-1563759-1
 TERMINAL: 1-241378-1 (WIRE SIZE: 0.20-0.35mm²)
 1-241380-1 (WIRE SIZE: 0.5-1.0mm²)
 1-418884-1 (WIRE SIZE: 1.0-1.5mm²)
 SEAL: 1718705-1 (WIRE O.D.: 0.9-1.2mm)
 964971-1 (WIRE O.D.: 1.2-1.6mm)
 963530-1 (WIRE O.D.: 1.4-1.9mm)
 CAVITY PLUG: 963531-1

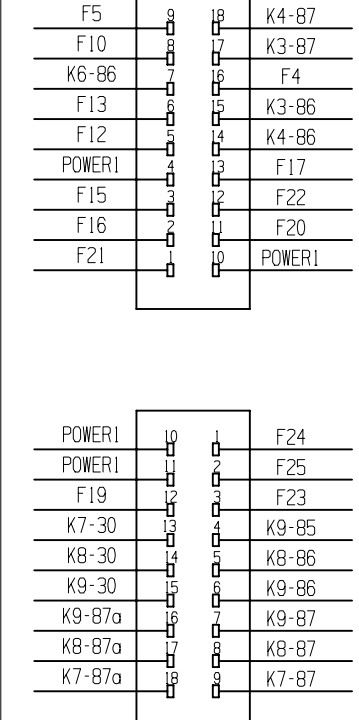

CONNECTOR: TYCO 3-1563759-1
 TERMINAL: 1-241378-1 (WIRE SIZE: 0.20-0.35mm²)
 1-241380-1 (WIRE SIZE: 0.5-1.0mm²)
 1-418884-1 (WIRE SIZE: 1.0-1.5mm²)
 SEAL: 1718705-1 (WIRE O.D.: 0.9-1.2mm)
 964971-1 (WIRE O.D.: 1.2-1.6mm)
 963530-1 (WIRE O.D.: 1.4-1.9mm)
 CAVITY PLUG: 963531-1

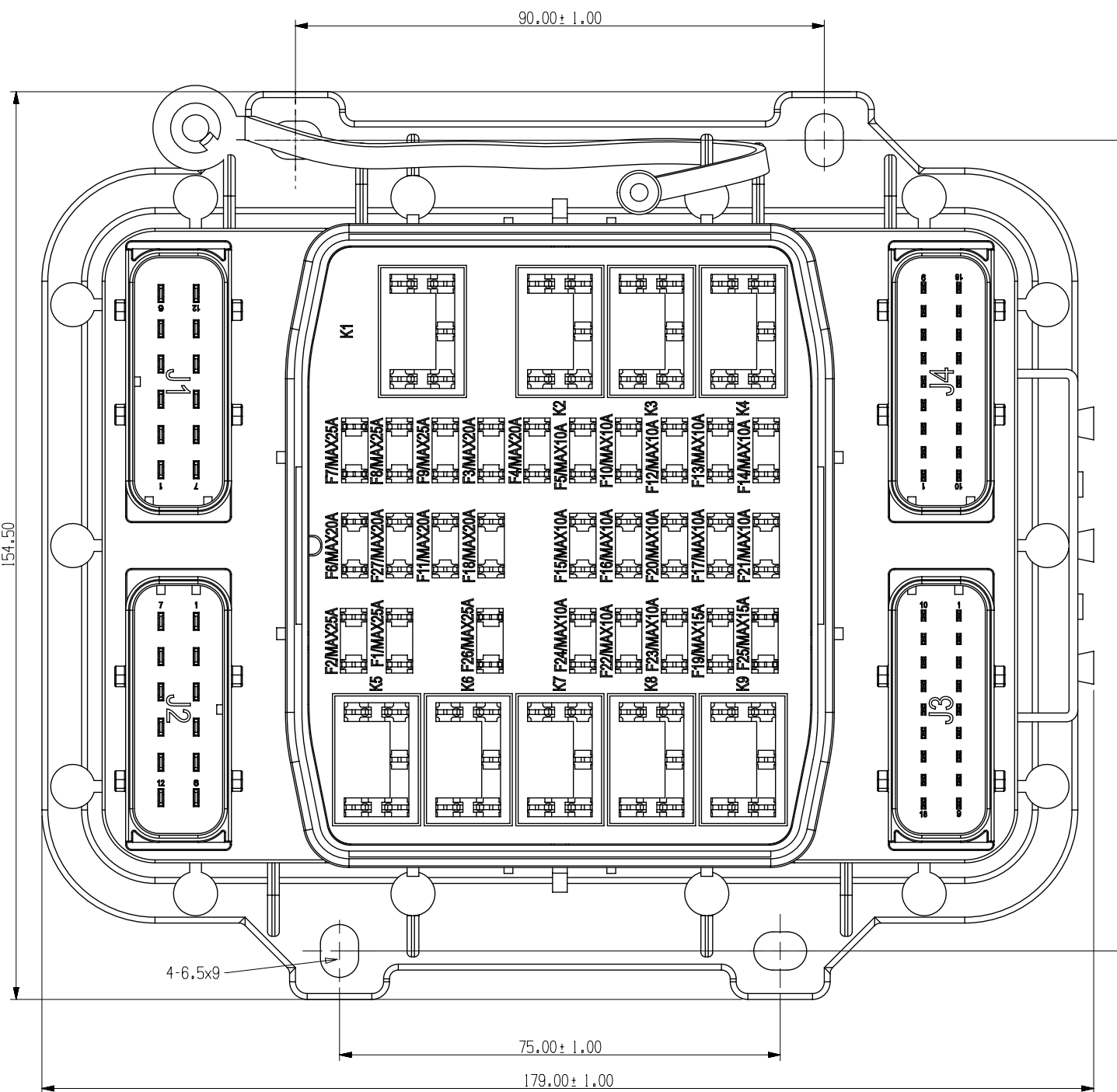

CONNECTOR: TYCO 2-1670901-1
 TERMINAL: 1-968882-1 (WIRE SIZE: 0.35mm²)
 1-968855-1 (WIRE SIZE: 0.5-1.0mm²)
 1-968857-1 (WIRE SIZE: 1.0-2.5mm²)
 1-1719506-1 (WIRE SIZE: AWG12 TXL)
 SEAL: 828904-1 (WIRE O.D.: 1.2-2.1mm)
 828905-1 (WIRE O.D.: 2.2-3.0mm, 3.2mm)
 CAVITY PLUG: 828922-1

- NOTES:
- A. MATERIAL: COVER/HOUSING/BASEPLATE/: PET GLASS FILLED (UL94-V01).
 TETHER: TPE.
 SCREWS: STEEL TIN PLATED
 GASKET: SILICON RUBBER
 - B. TAP SCREW TORQUE: 0.45±0.2NM.
 - C. ALL FUSE MUST NOT EXCEED 70% OF RATED CURRENT.
 - D. MAX. MAIN INPUT: 160A AT 85°C (POWER 1) MAX. 70A,
 POWER 2 MAX. 60A, EXTERNAL CURRENT MAX. 30A)
 - E. OPERATING TEMPERATURE RANGE: -40°C TO +105°C
 - F. RELAY AND FUSES INSERT ACCORDING TO LABEL.
 - G. M6 MOUNTING TORQUE: 6-8NM.

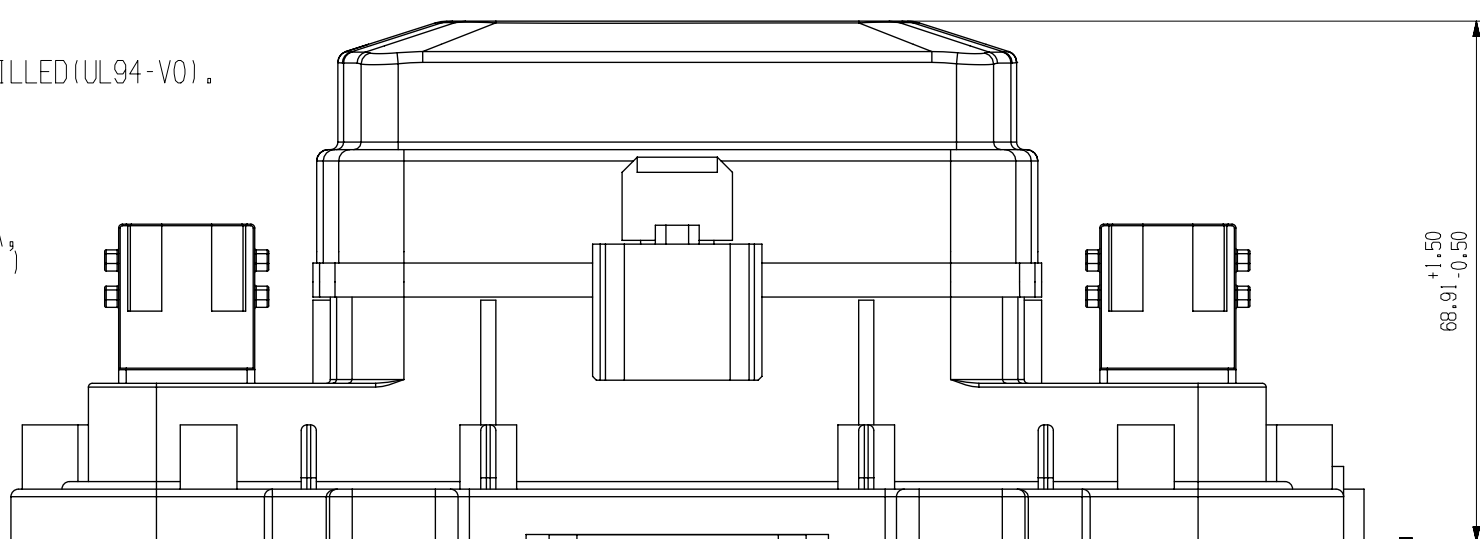

NO	COMPONENT NO	DESCRIPTION	QTY/M	U/M
BILL OF MATERIAL				
UNLESS OTHERWISE SPECIFIED, DIMENSIONS ARE IN MILLIMETERS. DIMENSIONS IN BRACKETS () ARE INCHES				
UNLESS OTHERWISE SPECIFIED, DIMENSIONS DO NOT INCLUDE PLATING.				
⊙	DENOTES CRITICAL CHARACTERISTICS.			
CPK	DENOTES CPK DIMENSIONS, -MINIMUM CPK VALUE			
ST	DENOTES A CHARACTERISTIC THAT PROVIDES AN INDICATION OF PROCESS PERFORMANCE. PROCEDURE FOR MEASUREMENT AND TRACKING TO BE DEFINED IN LITTELFUSE INSPECTION INSTRUCTIONS			
CP	DENOTES CP DIMENSIONS, -MINIMUM CP VALUE MUST BE WITHIN THE DIMENSIONAL LIMITATIONS SHOWN ON DRAWING AND INITIALLY LOCATED TO ALLOW FOR MAXIMUM TOOL LIFE			
COPIES TO	MATT SPEC SEE NOTES			
1	9	18	FINISH N/A	
2	10	19		
3	12	20		
4	13	21	DRW	FYUE DATE 23/Nov/17 SCALE 1:1
5	14	23	CHK	DATE SUPER DR
6	15	33	APPD	DATE FINISH GOOD WT
7	16	43		
8	17	53	GRAMS/PIECE	
TOLERANCES UNLESS OTHERWISE SPECIFIED (REF. ISO 2768-MH)				
DIMENSION	0.5 - 3	3 - 6	6 - 30	30 - 120
TOLERANCE	±0.1	±0.15	±0.2	±0.3
3RD ANGLE PROJECTION	TITLE MARKET EPC			
Littelfuse		REVISION	DRWG. NO.	
DES PLAINES, ILLINOIS 60016		C	01-LFLX0006Z-01	

METRIC ASSEMBLY

CAD GENERATED DRAWING - NO PENCIL CHANGES ALLOWED