

Ø52.3 ± 0.18
[Ø2.060 ± 0.007]

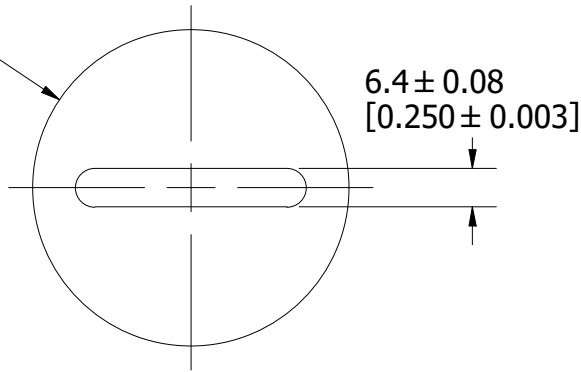

6.4 ± 0.08
[0.250 ± 0.003]

10.3 ± 0.13
[0.406 ± 0.005]

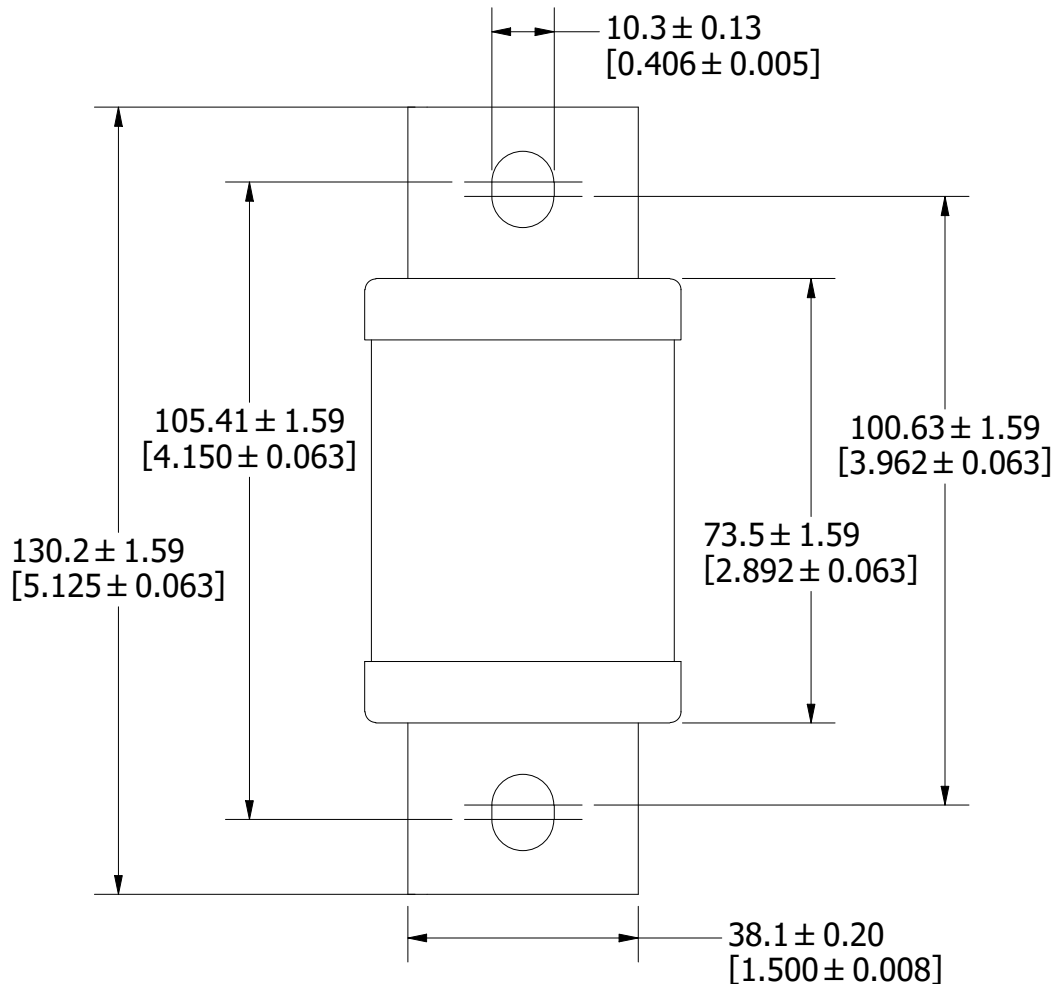

105.41 ± 1.59
[4.150 ± 0.063]

100.63 ± 1.59
[3.962 ± 0.063]

130.2 ± 1.59
[5.125 ± 0.063]

73.5 ± 1.59
[2.892 ± 0.063]

38.1 ± 0.20
[1.500 ± 0.008]

REVISION		
REV	DATE	DESCRIPTION
A	7/19/23	526717GCP - RELEASE MRY

1	NO	COMPONENT NO	DESCRIPTION	QTY/M	U/M
---	----	--------------	-------------	-------	-----

BILL OF MATERIAL

<S>	CRITICAL CHARACTERISTIC FOR PART SAFETY/COMPLIANCE				
●	DENOTES CRITICAL CHARACTERISTICS.				
CPK	DENOTES CPK DIMENSIONS, -MINIMUM CPK VALUE				
⊠	DENOTES A CHARACTERISTIC THAT PROVIDES AN INDICATION OF PROCESS PERFORMANCE. PROCEDURE FOR MEASUREMENT AND TRACKING TO BE DEFINED IN LITTELFUSE INSPECTION INSTRUCTIONS.				
CP	DENOTES CP DIMENSIONS, -MINIMUM CP VALUE MUST BE WITHIN THE DIMENSIONAL LIMITATIONS SHOWN ON DRAWING AND INITIALLY LOCATED TO ALLOW FOR MAXIMUM TOOL LIFE.				A

MATL SPEC		FINISH			
-----------	--	--------	--	--	--

DRW JMoler	DATE 6/23/2023	SCALE NTS	FINISH GOOD WT GRAMS/PIECE		
---------------	-------------------	--------------	-------------------------------	--	--

UNLESS OTHERWISE SPECIFIED, DIMENSIONS ARE IN MILLIMETERS, DIMENSIONS IN BRACKETS [] ARE INCHES DIMENSIONING AND DO NOT INCLUDE PLATING. TOLERANCING TO BE INTERPRETED IN ACCORDANCE WITH ANSI Y14.5M-1994

3RD ANGLE PROJECTION					
-------------------------	--	--	--	--	--

TITLE	L60S 450-600A OUTLINE				
--------------	-----------------------	--	--	--	--

 CHICAGO, ILLINOIS 60631	REVISION	DRWG NO.	SHEET 1 OF 1		
	A	OL-L60S600			