

PART No.	BODY	BODY STYLE	FUSE PROVIDED	FUSE RATING	REMARKS
OFHA0001Z	OFHA0001Z	1	NONE	-----	NOTE 1
OFHA0002Z	OFHA0002Z	2	NONE	-----	NOTE 2
OFHA0003Z	OFHA0001Z	1	0257003.P	3 AMP	NOTE 1
OFHA0004Z	OFHA0001Z	1	0257004.P	4 AMP	NOTE 1
OFHA0005Z	OFHA0001Z	1	0257005.P	5 AMP	NOTE 1
OFHA0075Z	OFHA0001Z	1	025707.5P	7.5 AMP	NOTE 1
OFHA0010Z	OFHA0001Z	1	0257010.P	10 AMP	NOTE 1
OFHA0015Z	OFHA0001Z	1	0257015.P	15 AMP	NOTE 1
OFHA0020Z	OFHA0001Z	1	0257020.P	20 AMP	NOTE 1
OFHA0025Z	OFHA0002Z	2	0257025.P	25 AMP	NOTE 2
OFHA0030Z	OFHA0002Z	2	0257030.P	30 AMP	NOTE 2

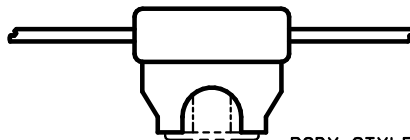

BODY STYLE #2

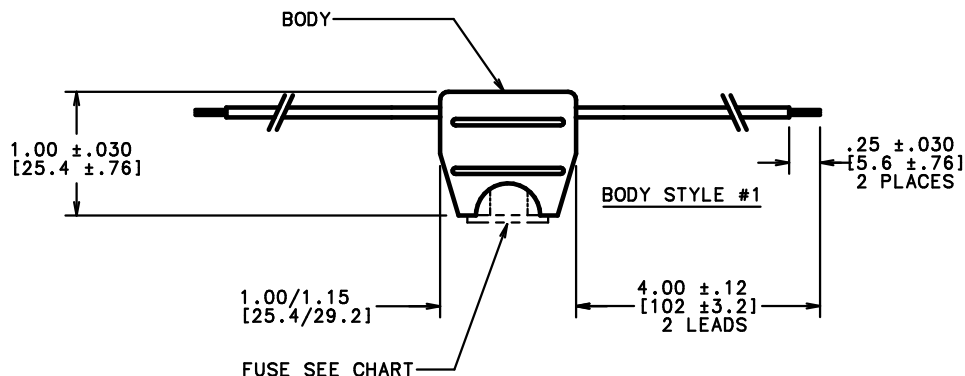

NOTES:

- FOR OFHA0001Z:
 - MAX. RATING: 20 AMPS, 32 VOLTS AT A MAX. OPERATING TEMPERATURE OF 180° F (82° C).
 - BODY MATERIAL: HIGH TEMPERATURE P.V.C., BLACK.
 - BLACK WIRE LEADS, #16 GAUGE, COPPER STRANDED (19 STRAND/29 GAUGE) PVC INSULATION, 0.016" THICK [0.406mm] AUTOMOTIVE LOW TENSION TYPE GPT/TW PER S.A.E. STRANDED J1128.
- FOR OFHA0002Z:
 - MAX. RATING: 30 AMPS, 32 VOLTS AT A MAX. OPERATING TEMPERATURE OF 180° F (82° C).
 - BODY MATERIAL: HIGH TEMPERATURE POLYURETHANE, BLACK.
 - ORANGE WIRE LEADS, #12 GAUGE, NOM. O.D. 0.136" [3.5mm], COPPER STRANDED (19 STRAND/25 GAUGE) PVC INSULATION, 0.026" THICK [0.660mm], RATED 300V, TEMP. RANGE: -10°C TO +80°C.

GENERAL NOTES:

- WIRE LEADS ARE MOLDED INTO FUSEHOLDER BODY.
- DIMENSIONS IN INCHES, [mm].

NO	COMPONENT NO	DESCRIPTION	QTY/M	U/M
BILL OF MATERIAL				
MATL SPEC		FINISH		
COPIES TO	DRW	JMB	SCALE	1=1
1	9		DATE	2/10/99
2	10		DATE	
3	12		DATE	
4	13		DATE	
5	14		DATE	
6	15		DATE	
7	16		DATE	
8	17		DATE	
TOLERANCE UNLESS OTHERWISE SPECIFIED				
TWO PLACE DEC ±.01				
THREE PLACE DEC ±.005				
ANGULAR ±1°				
TITLE				
AUTOFUSE HOLDER, INLINE (FUSE OPTIONAL)				
LTR		REVISION	CHK	APD
F		39728C- REVISED & REDRAWN ON NEW FORMAT 2/26/99 JMB		

DES PLAINES, ILLINOIS 60016

DRAWING NO. SERIES OUTLINE
 OFHA0000Z

UNLESS OTHERWISE SPECIFIED, DIMENSIONS DO NOT INCLUDE PLATING.
 DENOTES CRITICAL CHARACTERISTICS.
 DENOTES CPK DIMENSIONS--MINIMUM CPK VALUE
 DENOTES A CHARACTERISTIC THAT PROVIDES AN INDICATION
 OF PROCESS PERFORMANCE. REFERENCE PROCEDURE FOR MEASUREMENT
 (S) DENOTES THAT THE DIMENSIONAL LIMITATIONS
 ARE WITHIN THE DIMENSIONAL LIMITATIONS
 FOR MAXIMUM TOOL LIFE.

UNCONTROLLED DOCUMENT