

REVISION		DESCRIPTION
REV	DATE	
A	11/12/18	520094GCP - RELEASE MRY
B	9/16/19	521247ECP/D - ADD 35-60A MRY
C	6/9/20	522410ECP/D - CHG HEADER TO 1-4A, UPDATE NOTE 1 MRY

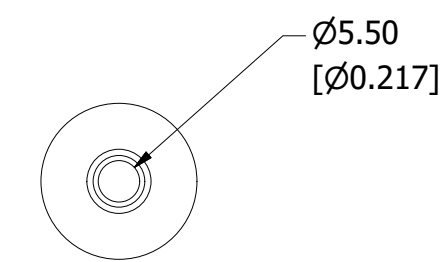
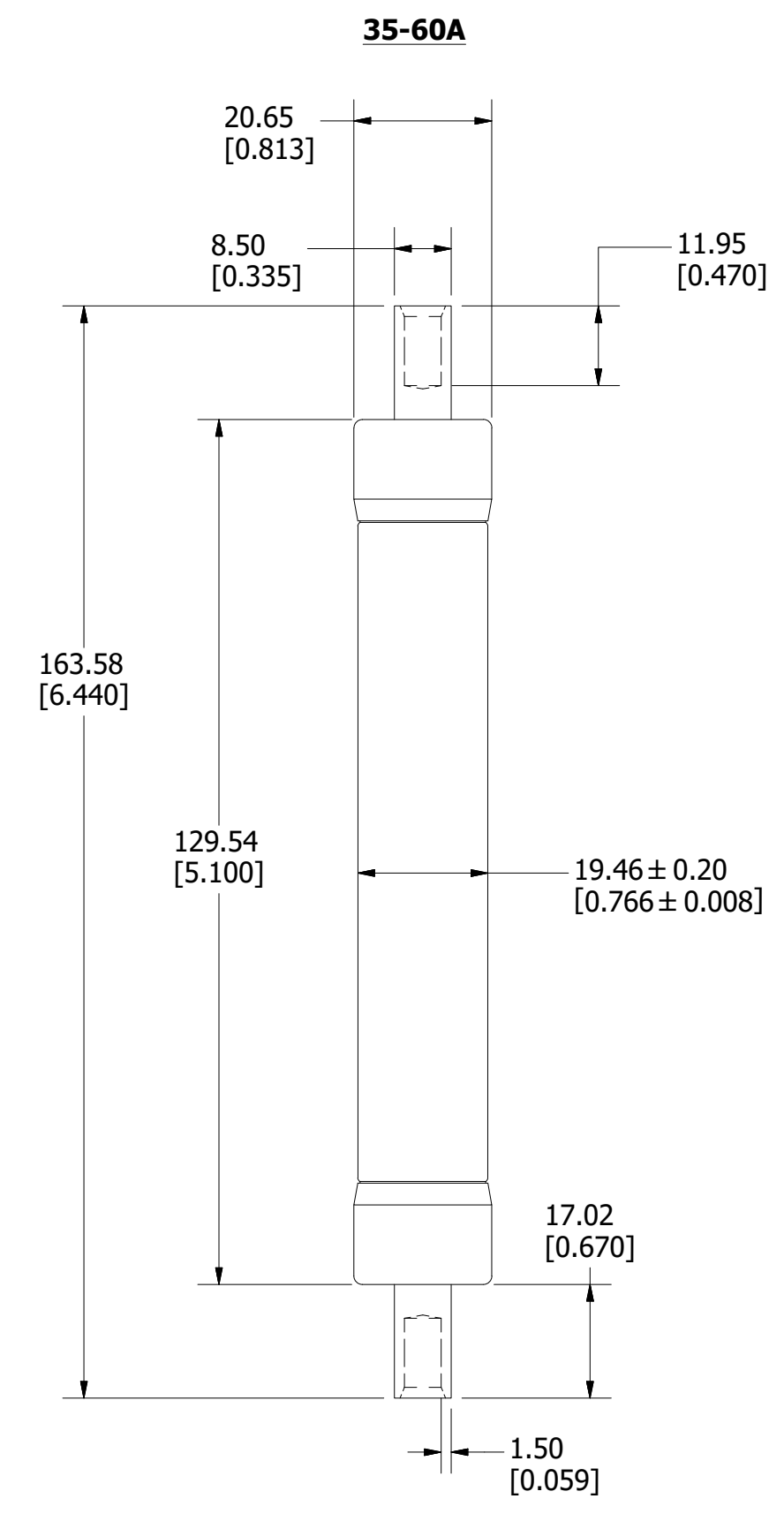
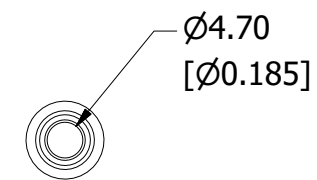
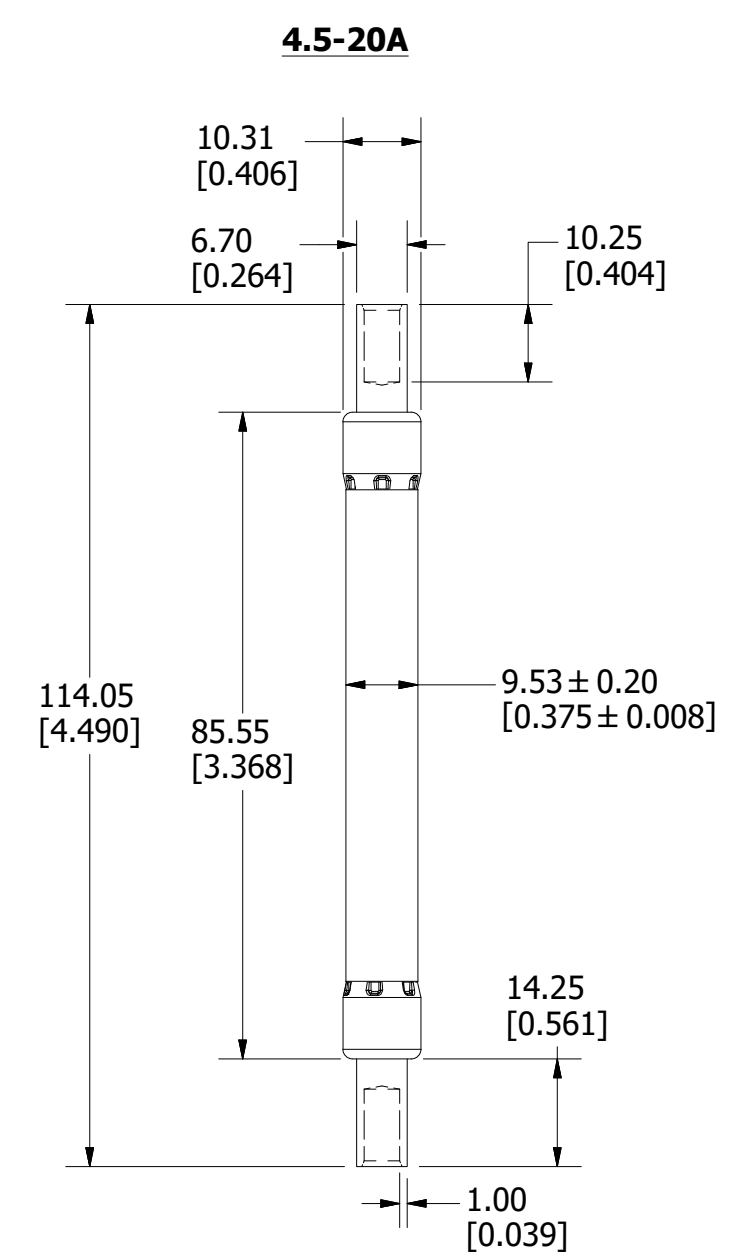
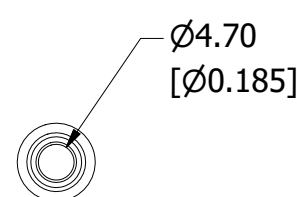
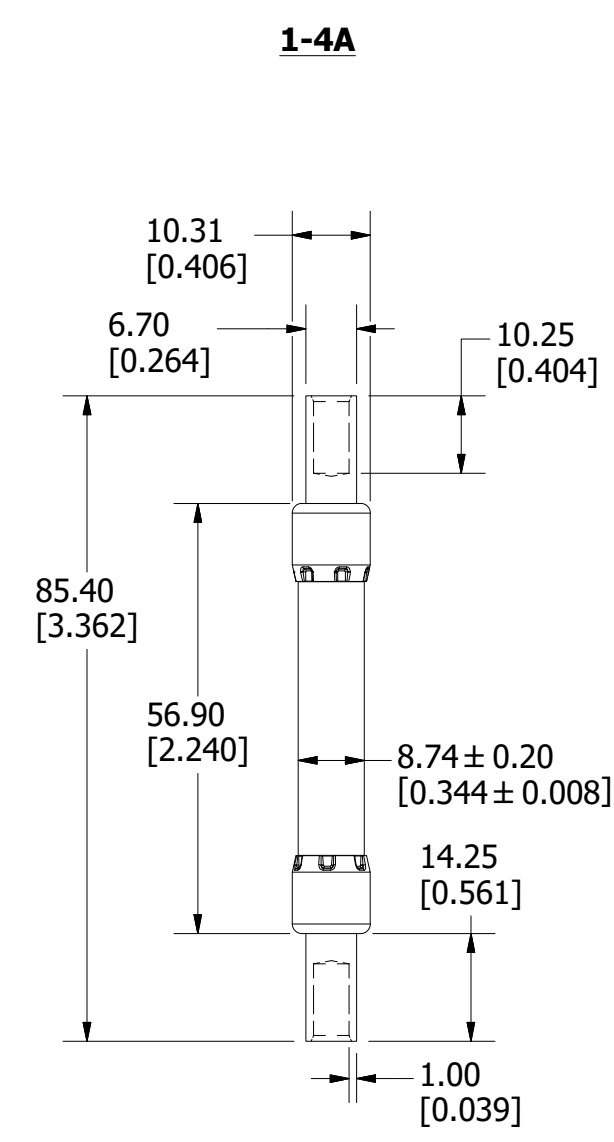

**NOTE:**  
 1. FUSES 20A AND BELOW SHALL PASS THROUGH A TUBULAR GAUGE HAVING A UNIFORM HOLE OF 0.414" MAX DIAMETER.

●	DENOTES CRITICAL CHARACTERISTICS.		
CPK	DENOTES CPK DIMENSIONS, -MINIMUM CPK VALUE		
(ST)	DENOTES A CHARACTERISTIC THAT PROVIDES AN INDICATION OF PROCESS PERFORMANCE. PROCEDURE FOR MEASUREMENT AND TRACKING TO BE DEFINED IN LITTELFUSE INSPECTION INSTRUCTIONS.		
CP	DENOTES CP DIMENSIONS, -MINIMUM CP VALUE MUST BE WITHIN THE DIMENSIONAL LIMITATIONS SHOWN ON DRAWING AND INITIALLY LOCATED TO ALLOW FOR MAXIMUM TOOL LIFE.		
MATL SPEC		FINISH	
DRW MYORK	DATE 7/16/2018	SCALE NTS	FINISH GOOD WT GRAMS/PIECE
UNLESS OTHERWISE SPECIFIED, DIMENSIONS ARE IN MILLIMETERS, DIMENSIONS IN BRACKETS [ ] ARE INCHES DIMENSIONING AND DO NOT INCLUDE PLATING. TOLERANCING TO BE INTERPRETED IN ACCORDANCE WITH ANSI Y14.5M-1994			
3RD ANGLE PROJECTION			
<b>TITLE</b> SPXI-B SERIES OUTLINE			
CHICAGO, ILLINOIS 60631		REVISION C	DRWG NO. OL-SPXI000B SHEET 1 OF 1